



US00D598986S

(12) **United States Design Patent**
Waymire

(10) **Patent No.:** **US D598,986 S**

(45) **Date of Patent:** **** Aug. 25, 2009**

(54) **OFF-CENTER DRAW AND RETURN TUBE FUEL ASSEMBLY**

(76) **Inventor:** **Evan Waymire**, 10240 SE. Mather Rd., Clackamas, OR (US) 97015

(**) **Term:** **14 Years**

(21) **Appl. No.:** **29/310,570**

(22) **Filed:** **Aug. 26, 2008**

(51) **LOC (9) Cl.** **23-01**

(52) **U.S. Cl.** **D23/266**

(58) **Field of Classification Search** D23/259-269; 285/7, 177, 394-395, 903, 307, 358, 179-183, 285/423; 292/58-59; 137/15.08, 590; 123/514
See application file for complete search history.

(56) **References Cited**

U.S. PATENT DOCUMENTS

4,212,318	A *	7/1980	Warmbold	137/590
4,340,023	A *	7/1982	Creager	123/510
4,651,701	A *	3/1987	Weaver	123/509
4,694,857	A *	9/1987	Harris	137/565.24
5,146,901	A *	9/1992	Jones	123/516
5,201,298	A *	4/1993	Shearn	123/514
5,533,486	A *	7/1996	Qutub	123/541
5,601,066	A *	2/1997	Qutub	123/541
D379,404	S *	5/1997	Spelts	D23/266
5,873,348	A *	2/1999	Fuchs et al.	123/514
6,098,599	A *	8/2000	Muldoon et al.	123/514
6,161,562	A *	12/2000	Keefer et al.	137/15.08
6,273,123	B1 *	8/2001	Keefer et al.	137/351
D458,354	S *	6/2002	Watson	D23/266

* cited by examiner

Primary Examiner—T. Chase Nelson

Assistant Examiner—Eric L Goodman

(74) *Attorney, Agent, or Firm*—Ingrid McTaggart

(57) **CLAIM**

The ornamental design for an off-center draw and return tube fuel assembly, as shown as described.

DESCRIPTION

The design is a draw and return tube fuel assembly that is used in a commercial vehicle fuel tank. A left hand version is used in a left hand fuel tank on the commercial vehicle and a right hand version is used in a right hand fuel tank on the commercial vehicle. The left hand version and the right hand version of the draw and return tube fuel assembly are mirror images of one another. The design claimed in this design patent covers both left hand and right hand versions of the draw and return tube fuel assembly even though only one version is shown for ease of illustration.

FIG. 1 is a perspective view of the off-center draw and return tube fuel assembly looking downwardly toward the front of the assembly.

FIG. 2 is a perspective view of the off-center draw and return tube fuel assembly looking downwardly toward the rear of the assembly.

FIG. 3 is a front view of the off-center draw and return tube fuel assembly;

FIG. 4 is a rear view of the off-center draw and return tube fuel assembly;

FIG. 5 is a top view of the off-center draw and return tube fuel assembly;

FIG. 6 is a right side view of the off-center draw and return tube fuel assembly;

FIG. 7 is a left side view of the off-center draw and return tube fuel assembly; and,

FIG. 8 is a bottom view of the off-center draw and return tube fuel assembly.

The broken line showing is included for the purpose of illustrating portions of the article and forms no part of the claimed design.

1 Claim, 4 Drawing Sheets

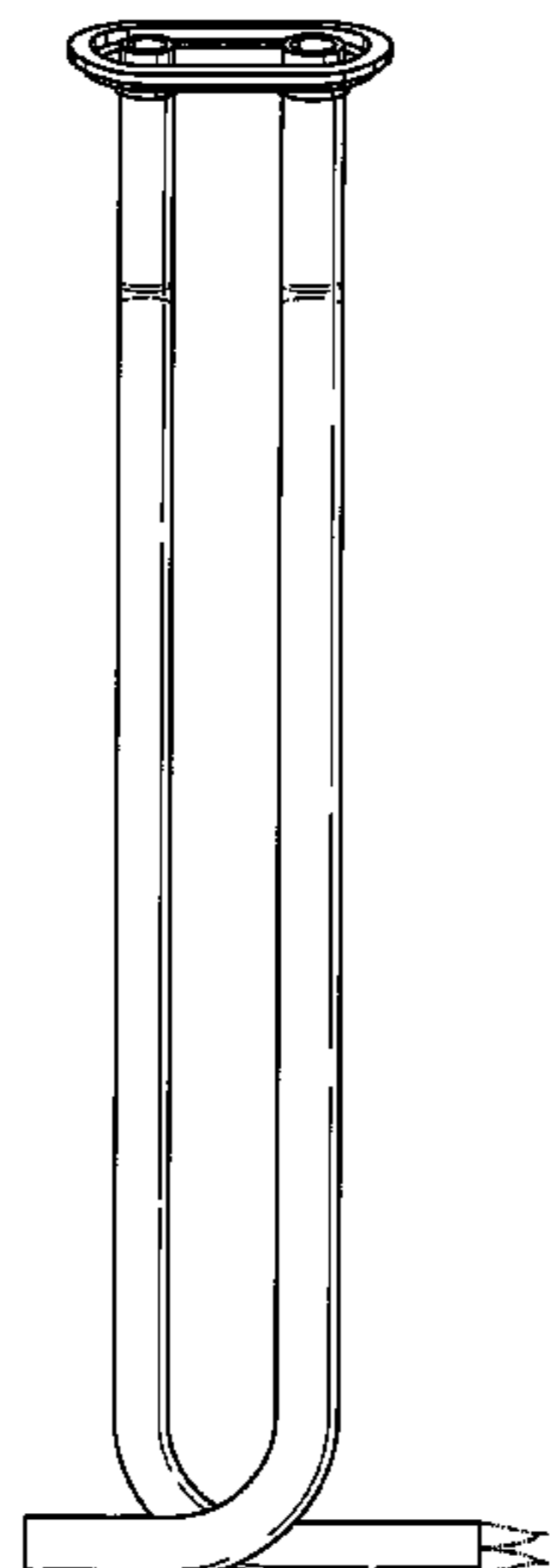

Fig. 1

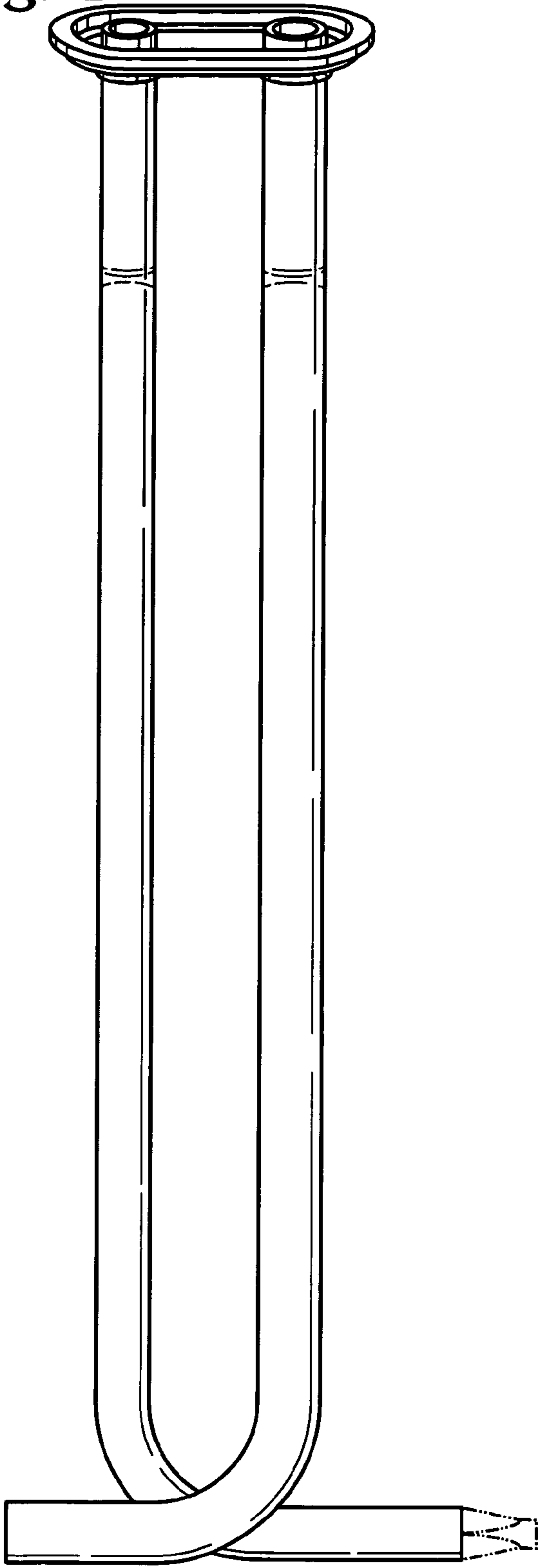

Fig. 2

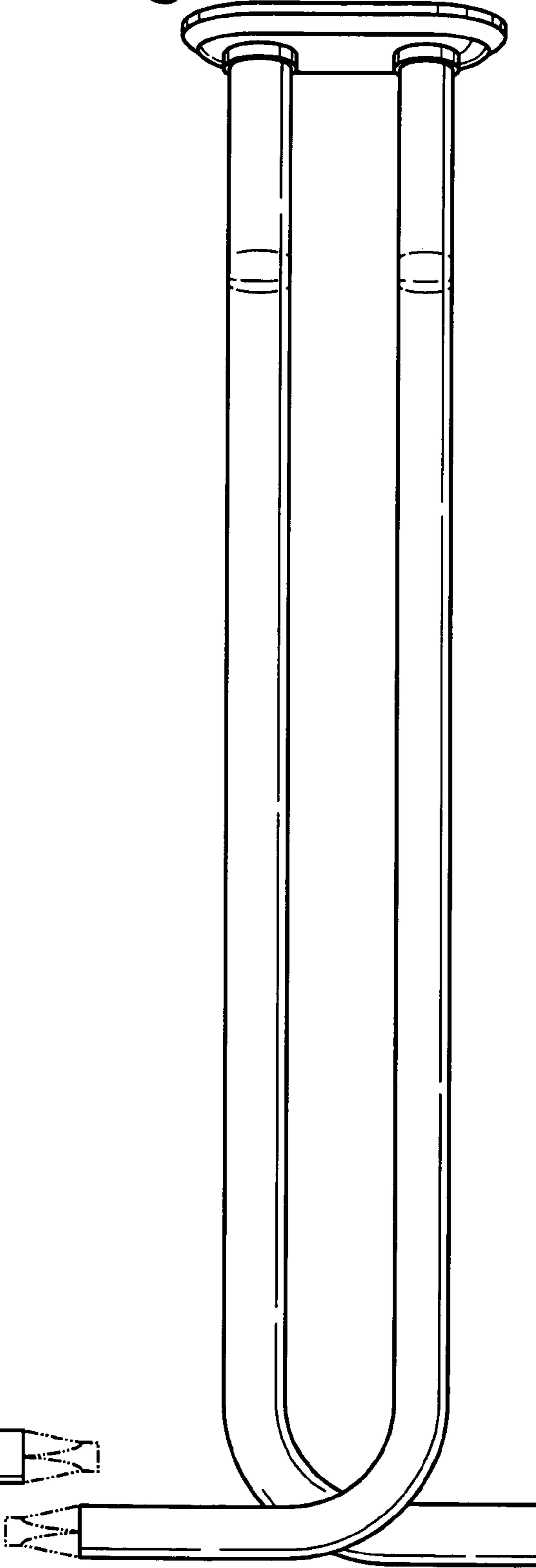

Fig. 3

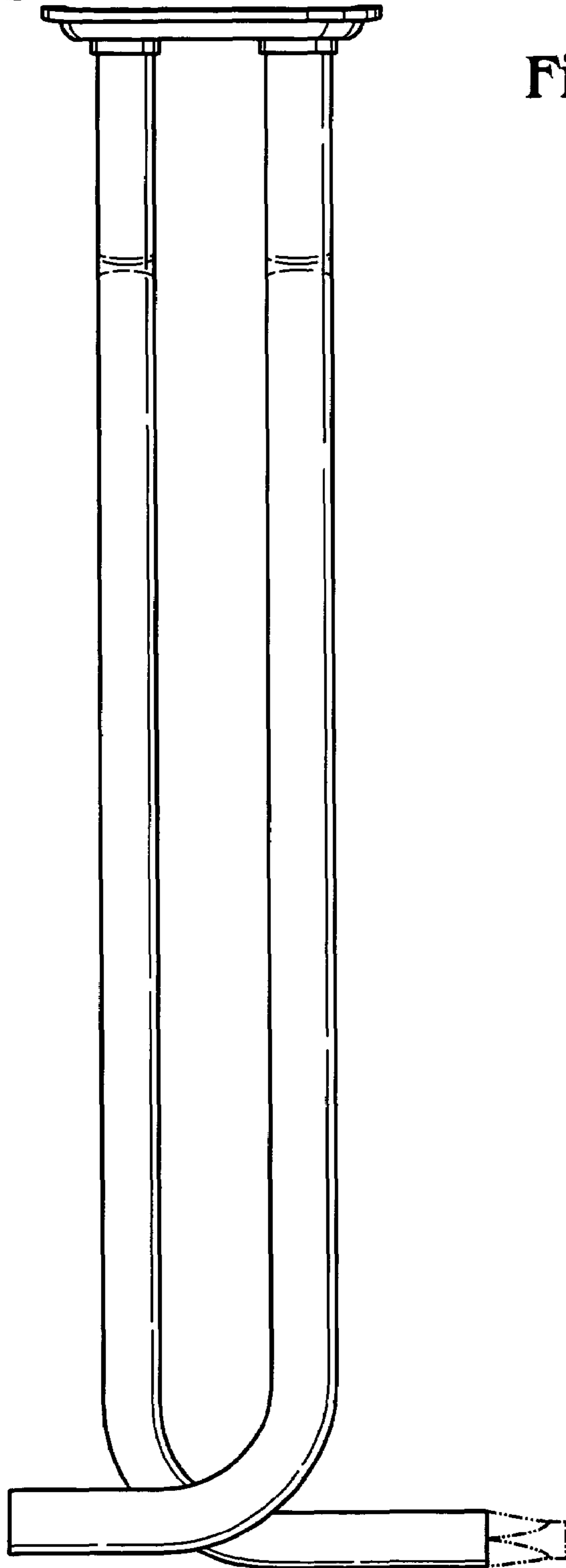

Fig. 4

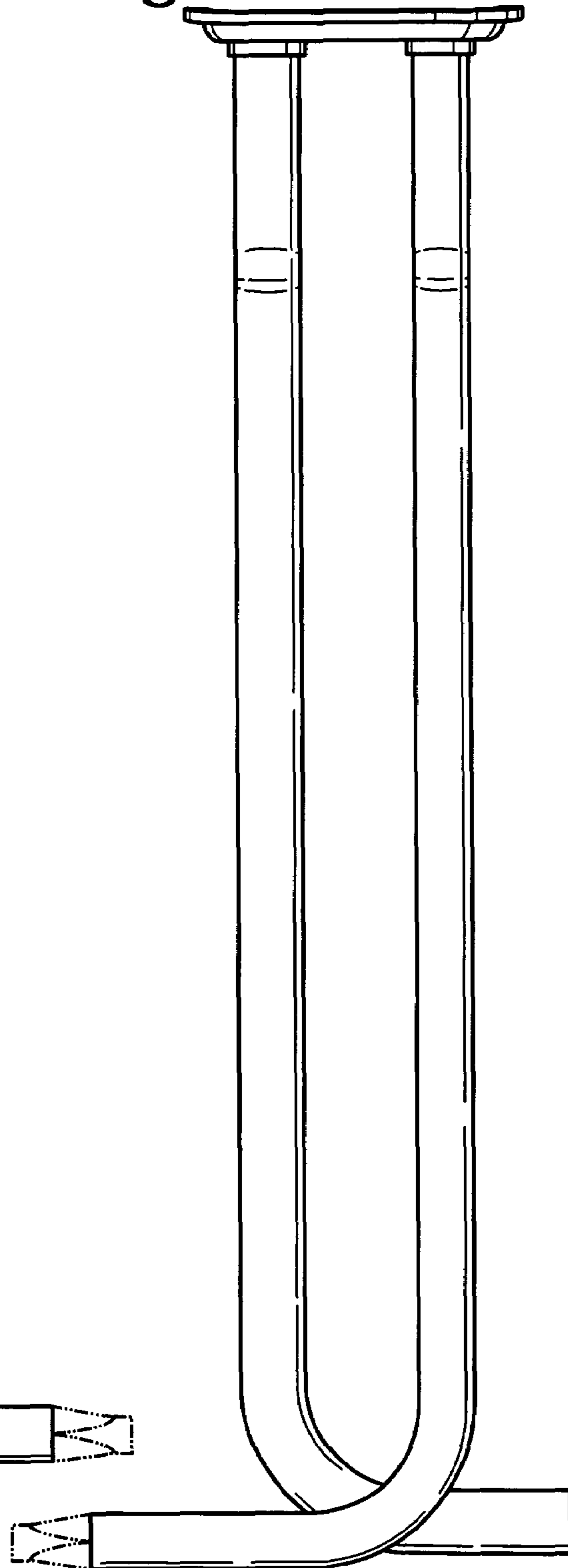

Fig. 5

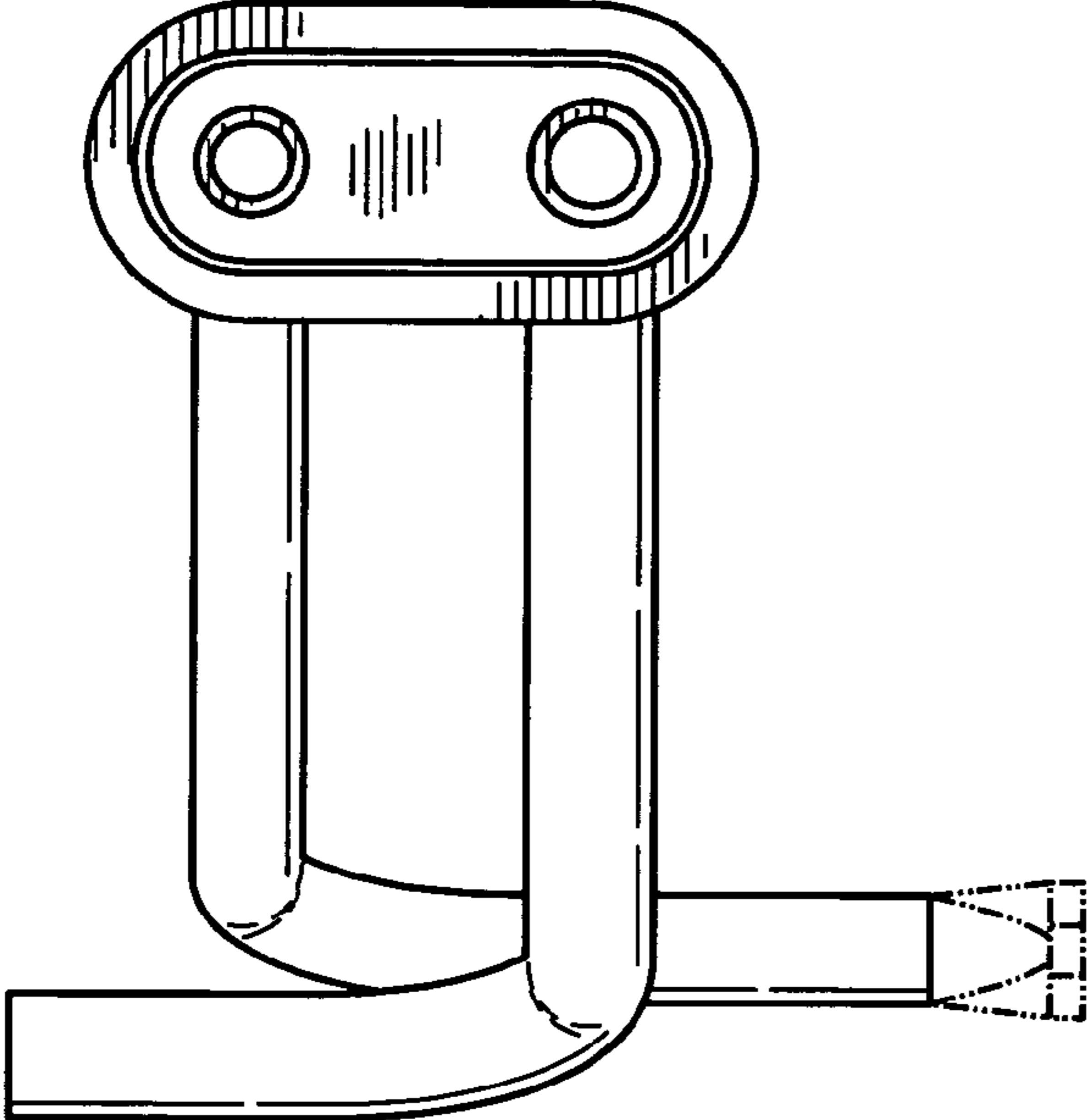

Fig. 6

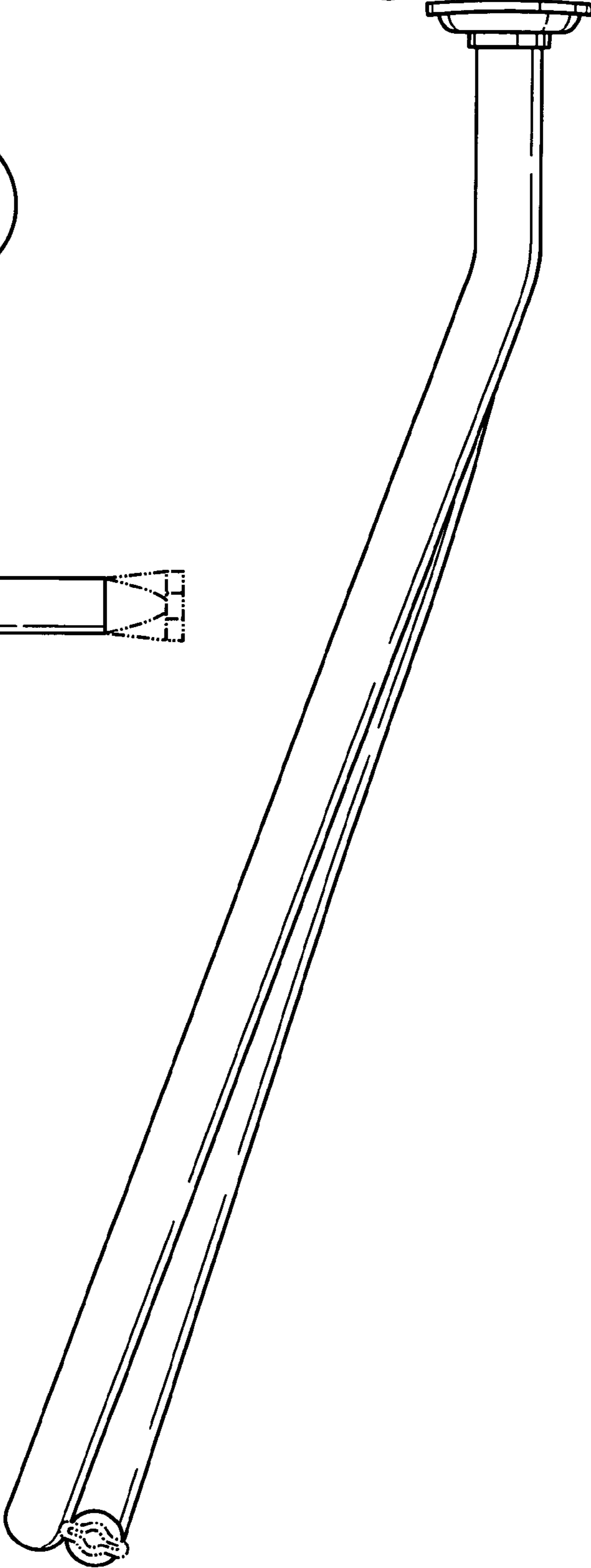

Fig. 7

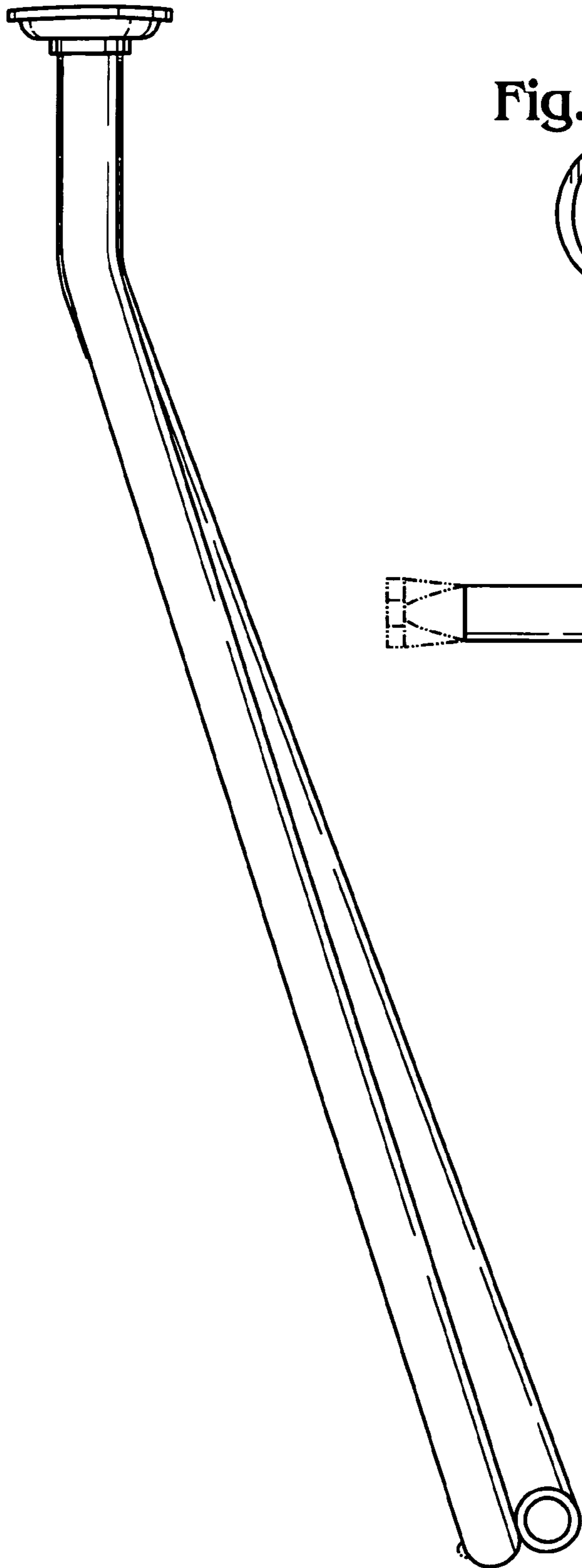

Fig. 8

