

US00D598935S

(12) **United States Design Patent**
Kobayashi et al.

(10) **Patent No.:** **US D598,935 S**

(45) **Date of Patent:** **** Aug. 25, 2009**

(54) **INTERNAL COMBUSTION ENGINE**

D529,046 S * 9/2006 Maeda et al. D15/1
D561,784 S * 2/2008 Yin et al. D15/1

(75) Inventors: **Masanori Kobayashi**, Kobe (JP);
Toshiro Inoue, Kobe (JP)

* cited by examiner

(73) Assignee: **Kawasaki Jukogyo Kabushiki Kaisha**,
Hyogo (JP)

Primary Examiner—Ian Simmons
Assistant Examiner—Wan Laymon

(**) Term: **14 Years**

(57) **CLAIM**

(21) Appl. No.: **29/286,001**

The ornamental design for an internal combustion engine, as shown and described.

(22) Filed: **Apr. 19, 2007**

(30) **Foreign Application Priority Data**

Oct. 23, 2006 (JP) 2006-028755

(51) **LOC (9) Cl.** **15-01**

(52) **U.S. Cl.** **D15/1**

(58) **Field of Classification Search** D15/1,
D15/3, 5, 14, 17, 149; 74/606 R; 123/22,
123/41.34, 51 A, 52.1, 50 A, 50 B, 54.1,
123/54.2, 54.4, 54.5, 65 R, 195 R, 195 HC,
123/657, 311

See application file for complete search history.

(56) **References Cited**

U.S. PATENT DOCUMENTS

D294,832 S * 3/1988 Itou et al. D15/1
D309,458 S * 7/1990 Johnson et al. D15/1
D309,611 S * 7/1990 Yamada D15/1
D367,070 S * 2/1996 Maeda et al. D15/1
D396,476 S * 7/1998 Shimizu D15/1
D515,589 S * 2/2006 Lin et al. D15/1
D521,529 S * 5/2006 Wu et al. D15/1
D527,020 S * 8/2006 Miyazaki et al. D15/3

DESCRIPTION

FIG. 1 is a front elevational view of an internal combustion engine showing our new design;

FIG. 2 is a rear elevational view thereof;

FIG. 3 is a left side elevational view thereof;

FIG. 4 is a right side elevational view thereof;

FIG. 5 is a top plan view thereof;

FIG. 6 is a bottom plan view thereof;

FIG. 7 is a front perspective view thereof; and,

FIG. 8 is a rear perspective view thereof.

The broken lines showing portions of the internal combustion engine as seen in FIGS. 2, 4–5 and 8 are included for the purpose of illustrating environmental structure and forms no part of the claimed design.

The trademark “Kawasaki” and warning messages in the drawings form no part of the claimed design.

The “Kawasaki” is a registered trademark of Kawasaki Jukogyo Kabushiki Kaisha.

1 Claim, 8 Drawing Sheets

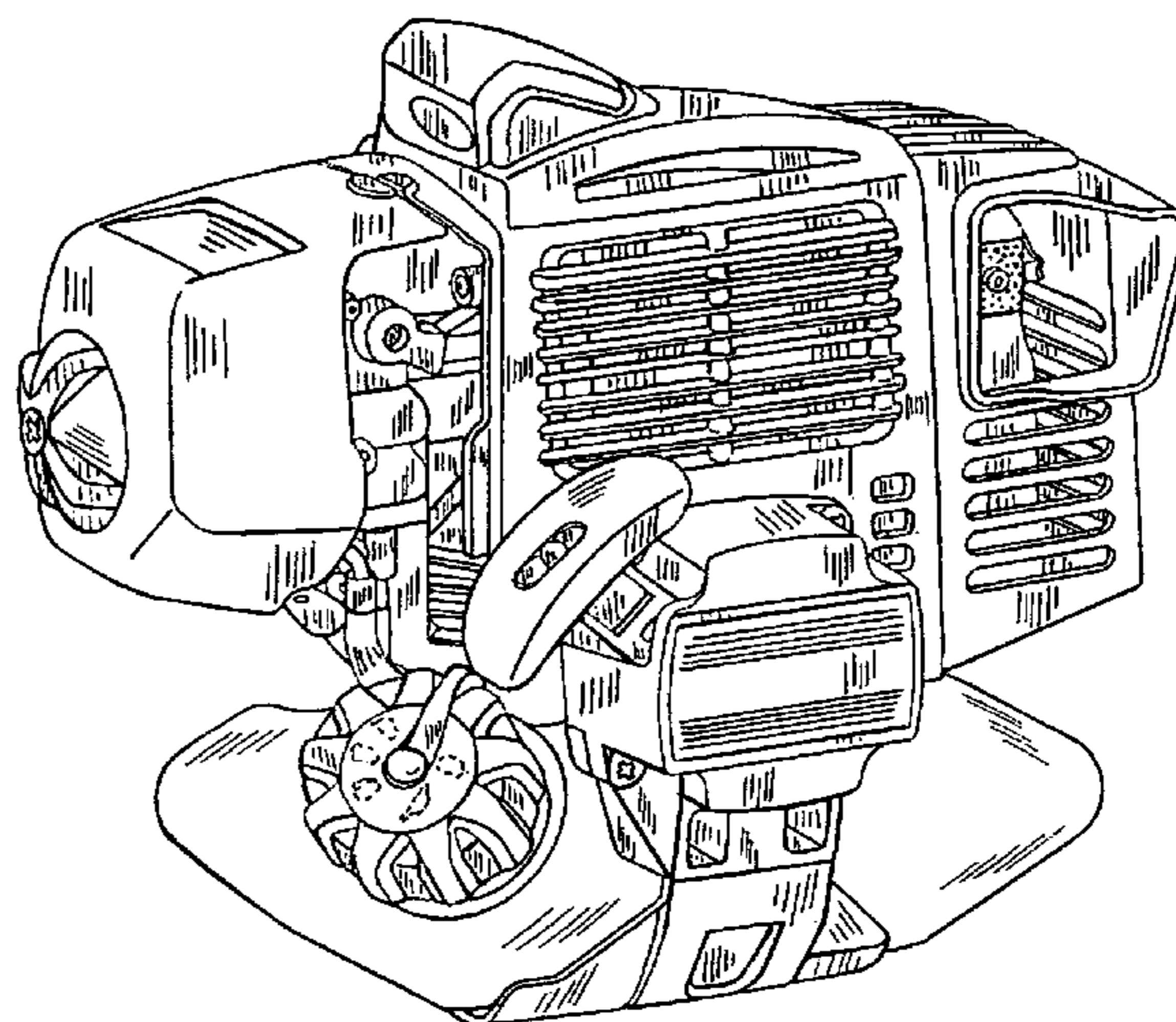
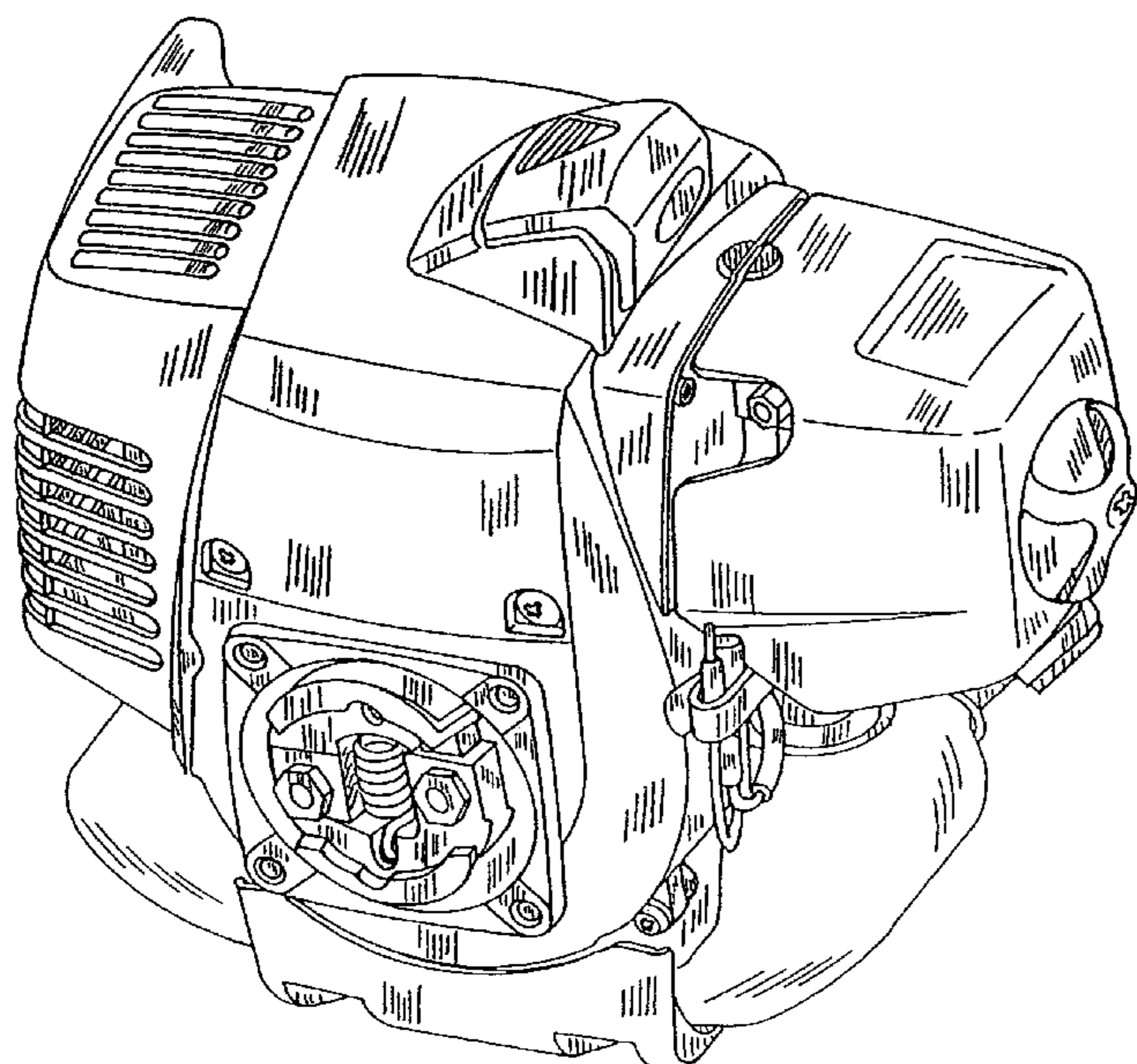

FIG. 1

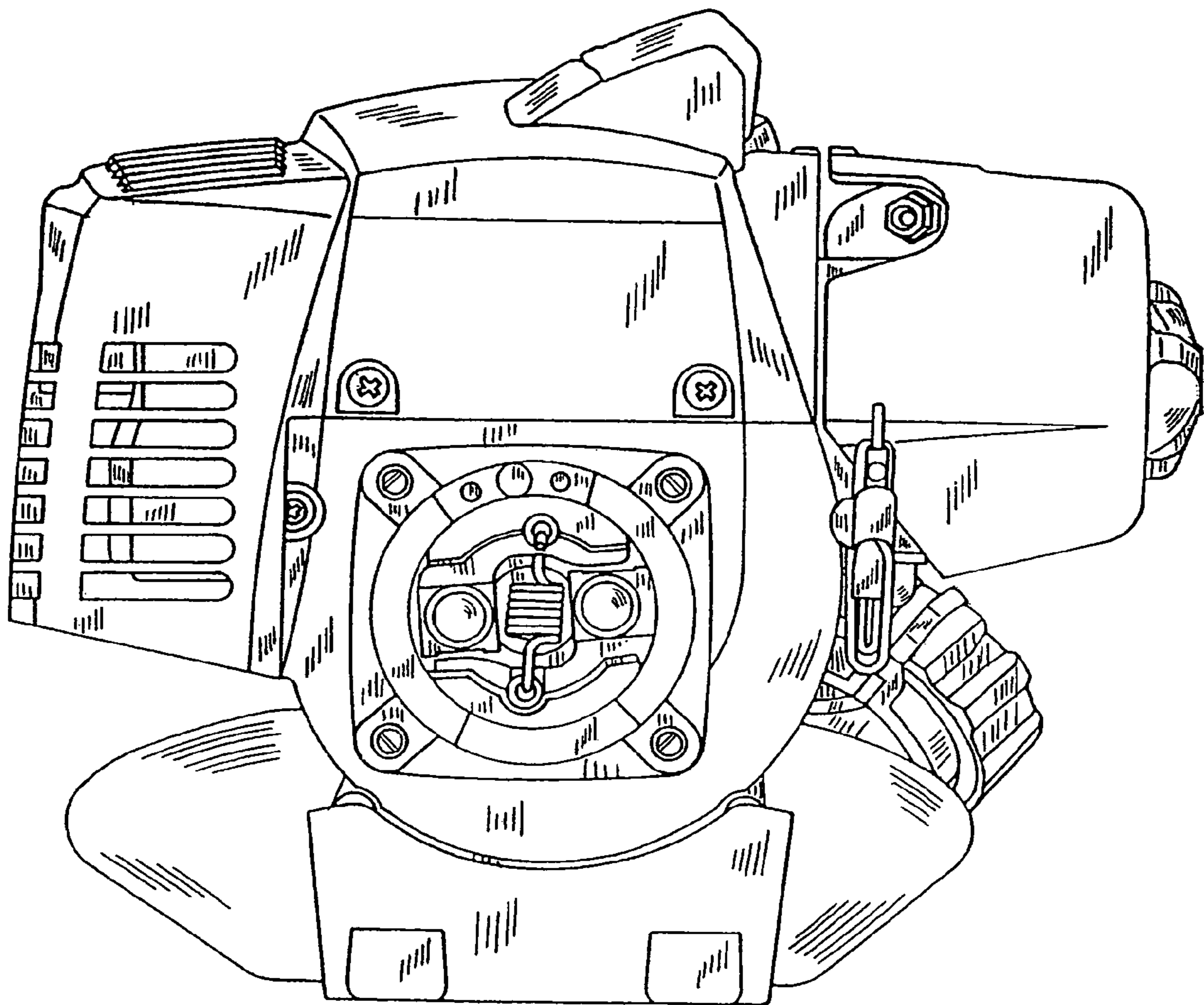

FIG. 2

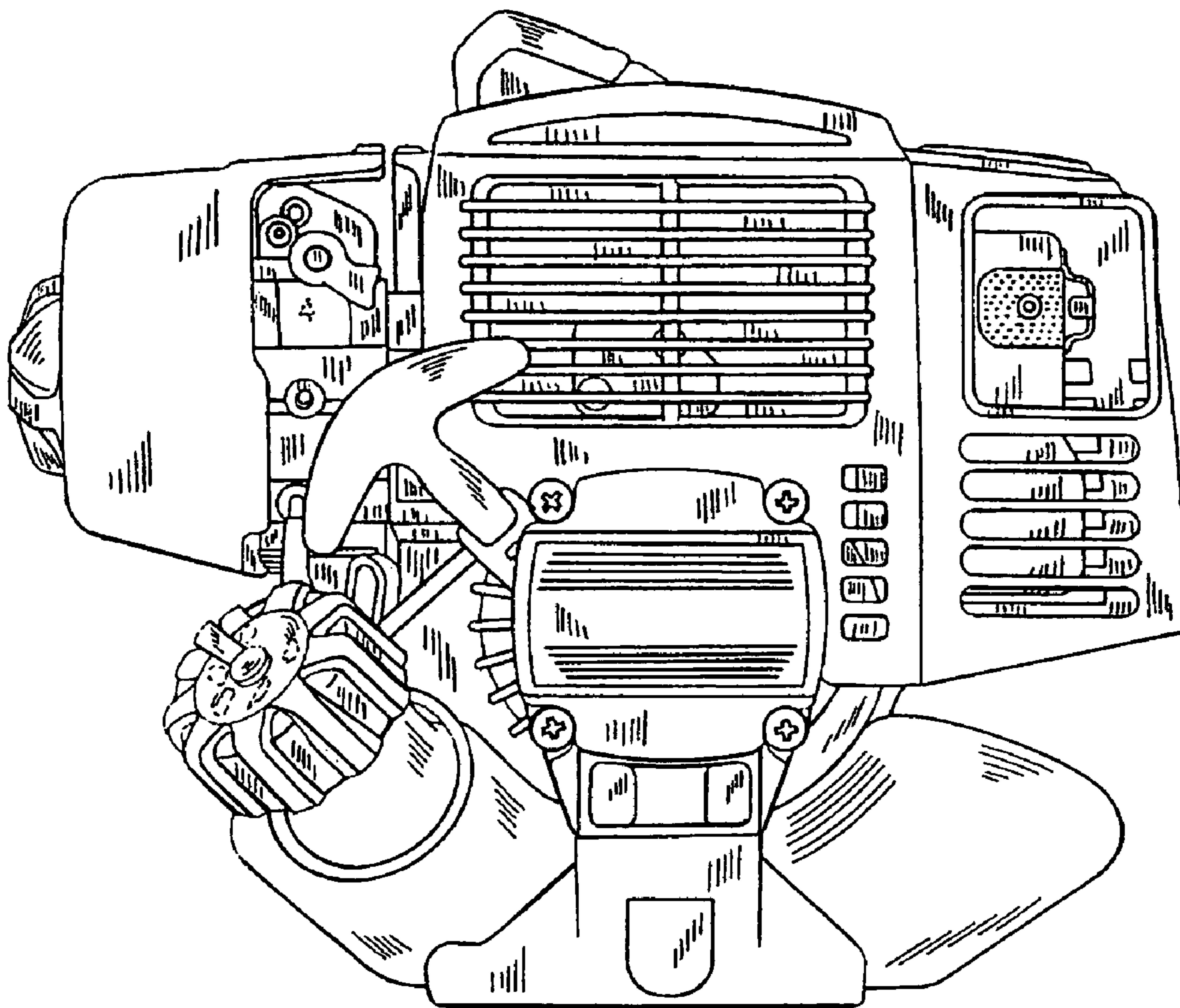

FIG. 3

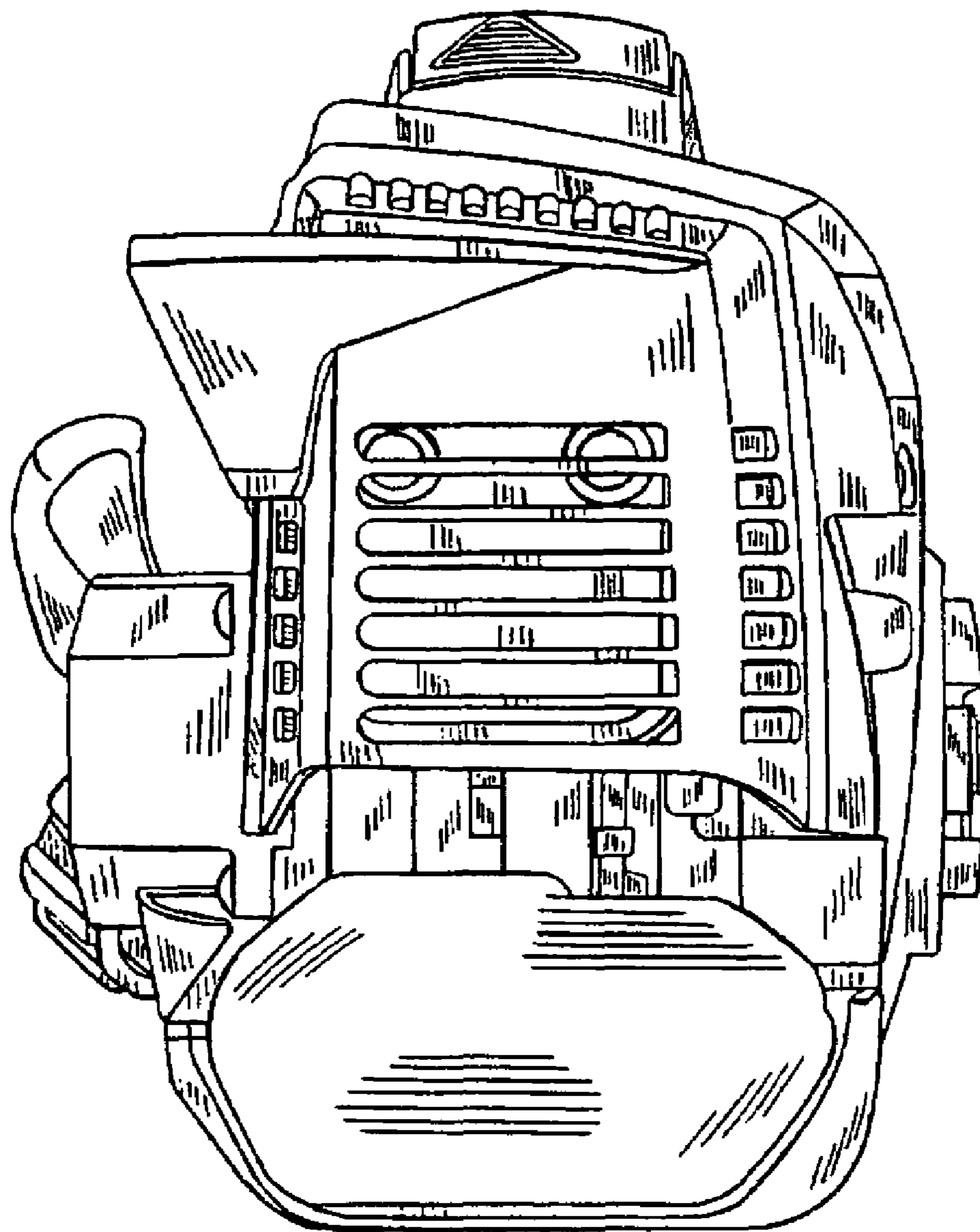

FIG. 4

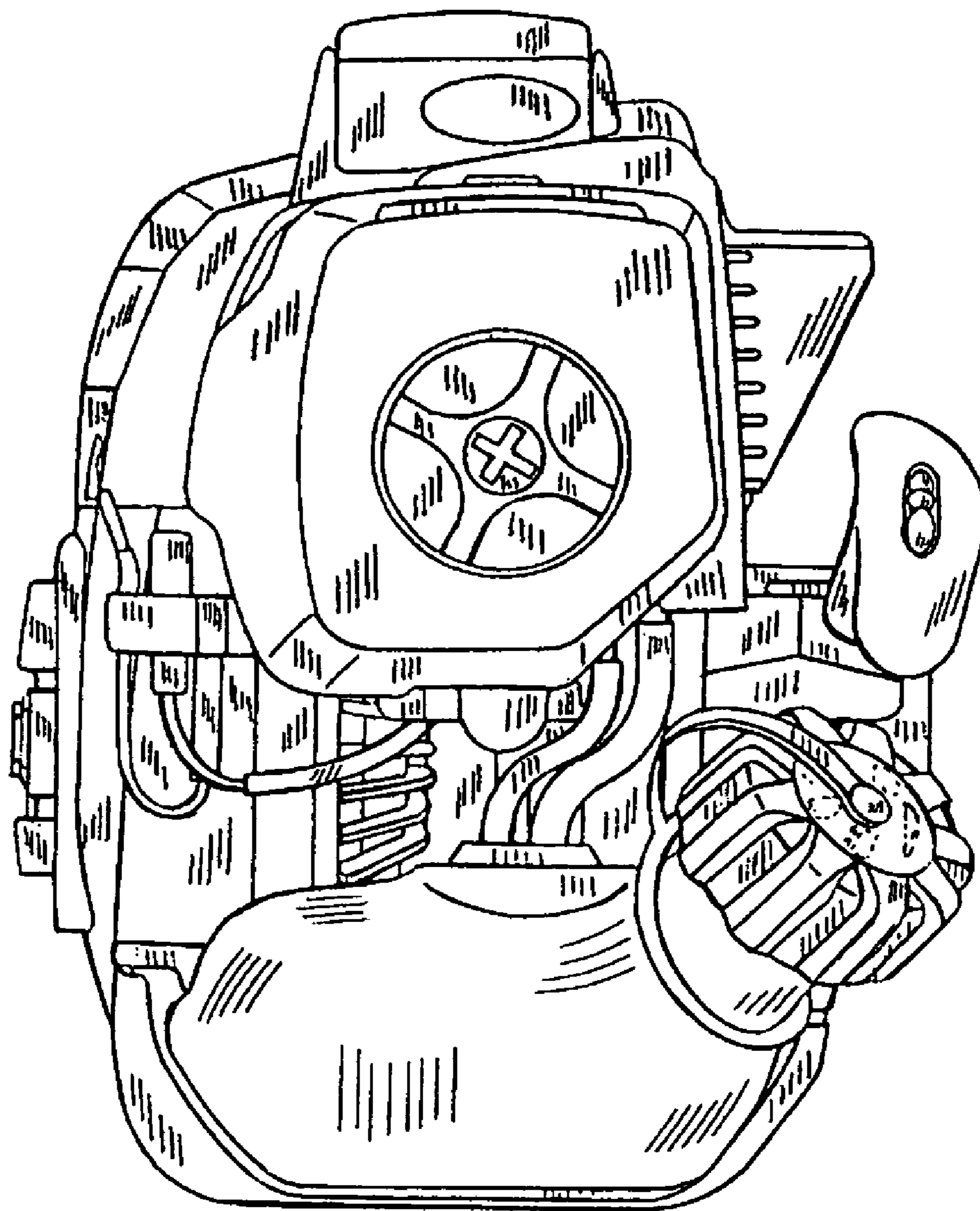

FIG. 5

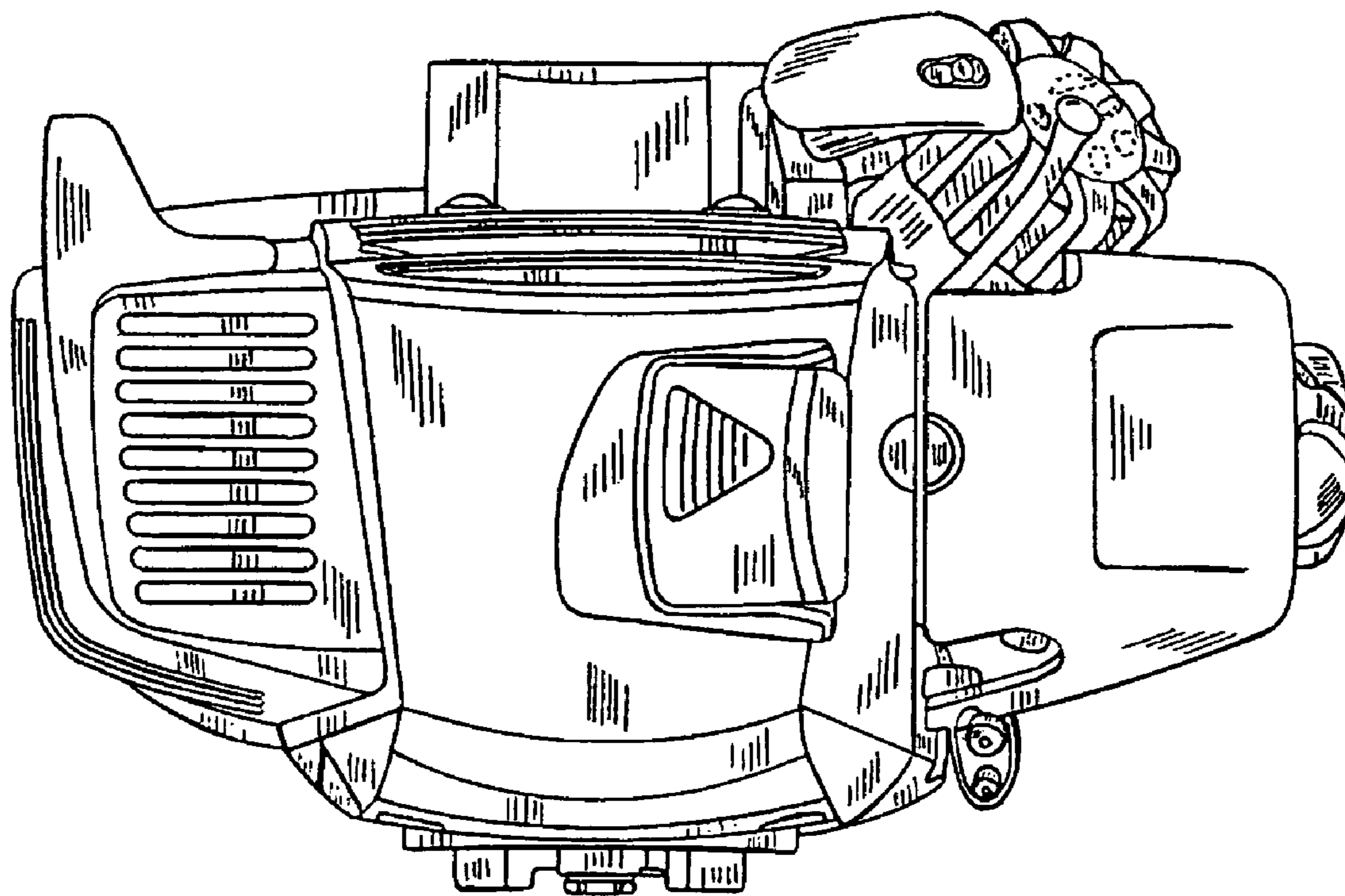

FIG. 6

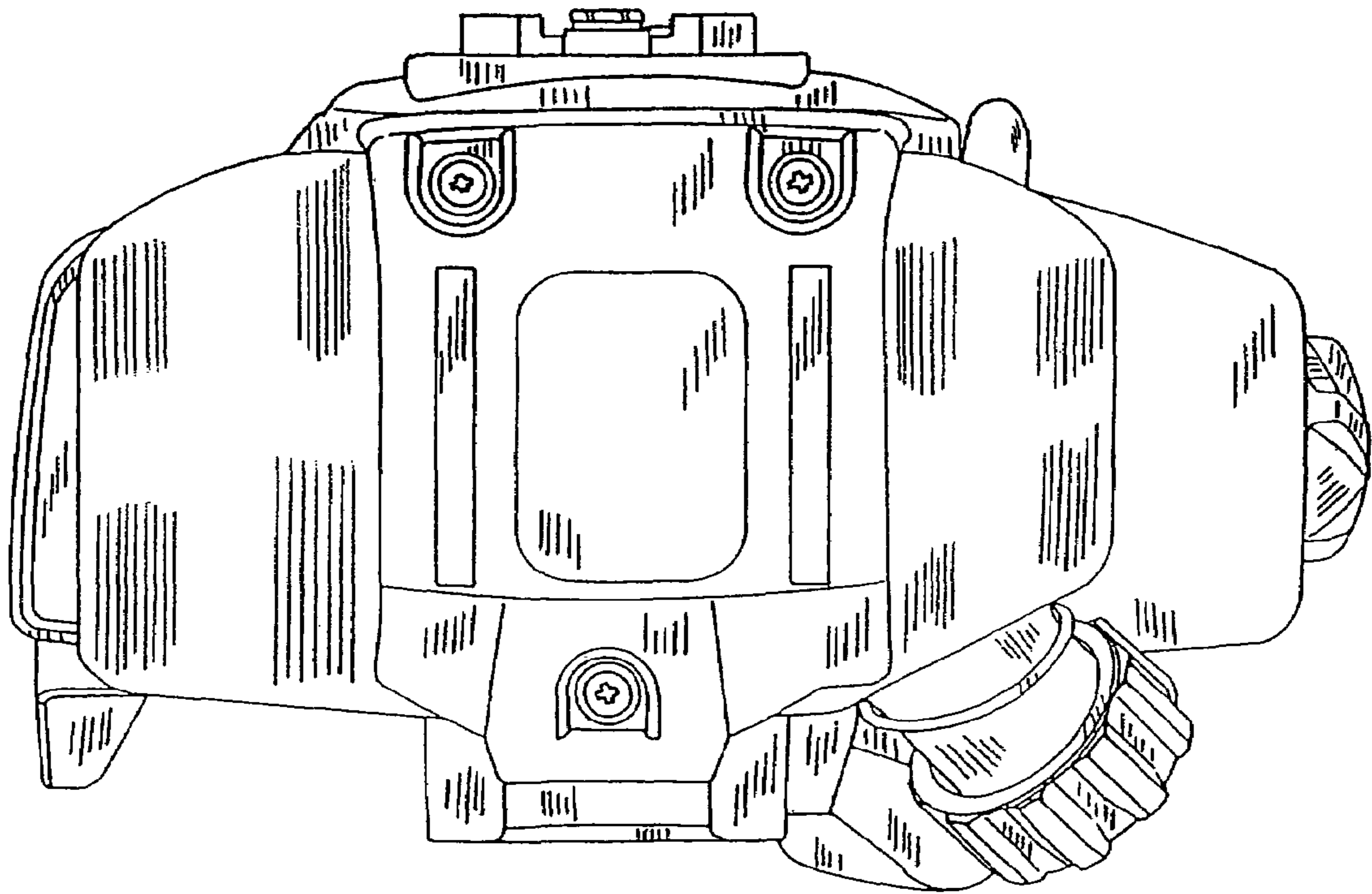

FIG. 7

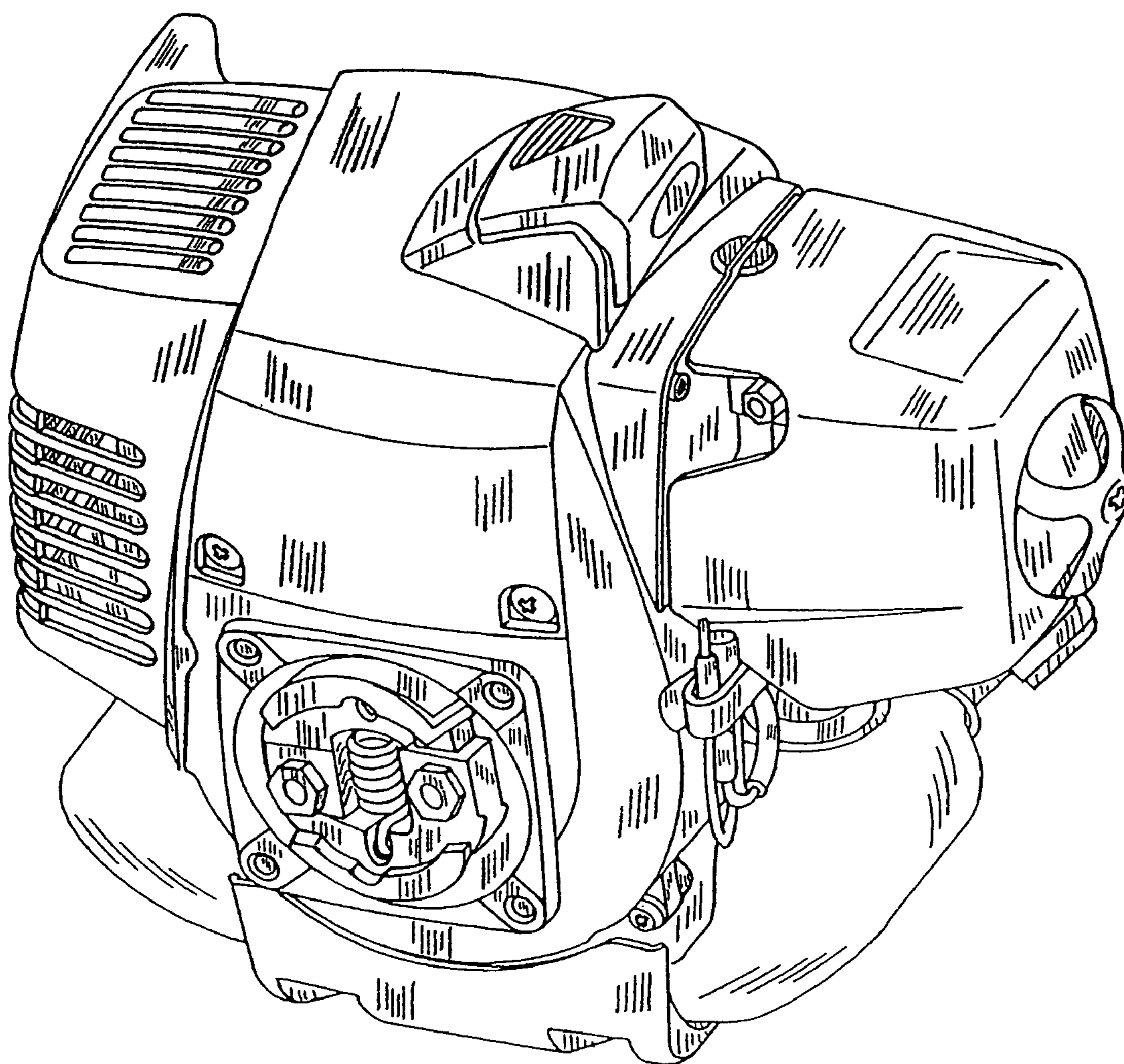

FIG. 8

