



US00D598904S

(12) **United States Design Patent**
Ho

(10) **Patent No.:** **US D598,904 S**
(45) **Date of Patent:** **** Aug. 25, 2009**

(54) **OVAL SATELLITE RECEIVE ANTENNA**

(75) Inventor: **Kesse Ho**, Westminster, CA (US)

(73) Assignee: **The DIRECTV Group, Inc.**, El Segundo, CA (US)

(**) Term: **14 Years**

(21) Appl. No.: **29/253,323**

(22) Filed: **Feb. 3, 2006**

(51) **LOC (9) Cl.** **12-03**

(52) **U.S. Cl.** **D14/231**

(58) **Field of Classification Search** D14/218,
D14/230, 231, 238, 232, 234, 235, 237; 343/878,
343/880, 840, 872, 881, 763, 720, 912, 908,
343/907, 761, 882, 786

See application file for complete search history.

(56) **References Cited**

U.S. PATENT DOCUMENTS

D322,254	S	*	12/1991	Su	D14/231
D362,443	S	*	9/1995	Inoue	D14/231
D362,444	S	*	9/1995	Schneeman	D14/231
D389,155	S	*	1/1998	Inoue	D14/231
D409,622	S	*	5/1999	Inoue	D14/231
D411,999	S	*	7/1999	Inoue	D14/231
D413,603	S		9/1999	Inoue		
D433,014	S	*	10/2000	Rogers	D14/231
D440,962	S	*	4/2001	Inoue	D14/231
D441,741	S	*	5/2001	Inoue	D14/231
D452,229	S	*	12/2001	Sato	D14/231
D453,330	S		2/2002	Weaver		
D458,598	S	*	6/2002	Sato	D14/231
6,445,361	B2	*	9/2002	Liu et al.	343/882
6,570,542	B2	*	5/2003	Jan et al.	343/778
6,864,850	B2	*	3/2005	Imaizumi et al.	343/776
6,864,855	B1	*	3/2005	Fujita	343/882
2001/0054984	A1	*	12/2001	Spirtus	343/840
2002/0140617	A1	*	10/2002	Luly et al.	343/781 CA
2004/0021614	A1	*	2/2004	Moheb	343/840

2005/0057428	A1	*	3/2005	Fujita	343/882
2007/0210980	A1	*	9/2007	Shen	343/912
2007/0247390	A1	*	10/2007	Lin et al.	343/892
2008/0062059	A1	*	3/2008	Freni et al.	343/840

OTHER PUBLICATIONS

International Search Report and Written Opinion dated May 19, 2008 in International counterpart Application No. PCT/US06/30656 corresponding to U.S. Appl. No. 29/253,323, filed Feb. 3, 2006 by Kesse Ho.

* cited by examiner

Primary Examiner—T. Chase Nelson
Assistant Examiner—Ania K Dworzecka

(57) **CLAIM**

The ornamental design for an oval satellite receive antenna, as shown and described.

DESCRIPTION

FIG. 1 illustrates a perspective view of an oval satellite receive antenna of the present invention;

FIG. 2 illustrates a front view thereof;

FIG. 3 illustrates a right side elevational view thereof;

FIG. 4 illustrates a second perspective view thereof;

FIG. 5 illustrates an enlarged perspective view of the low noise block amplifier (LNB) strip portion of the antenna of the present invention;

FIG. 6 illustrates a view of the LNB strip that faces toward the antenna of the present invention;

FIG. 7 illustrates a right side elevational view of the LNB strip portion of the antenna of the present invention; and,

FIG. 8 illustrates a top plan view of the LNB portion of the antenna of the present invention.

In the drawings, the broken lines depict environmental subject matter only and form no part of the claimed design.

1 Claim, 8 Drawing Sheets

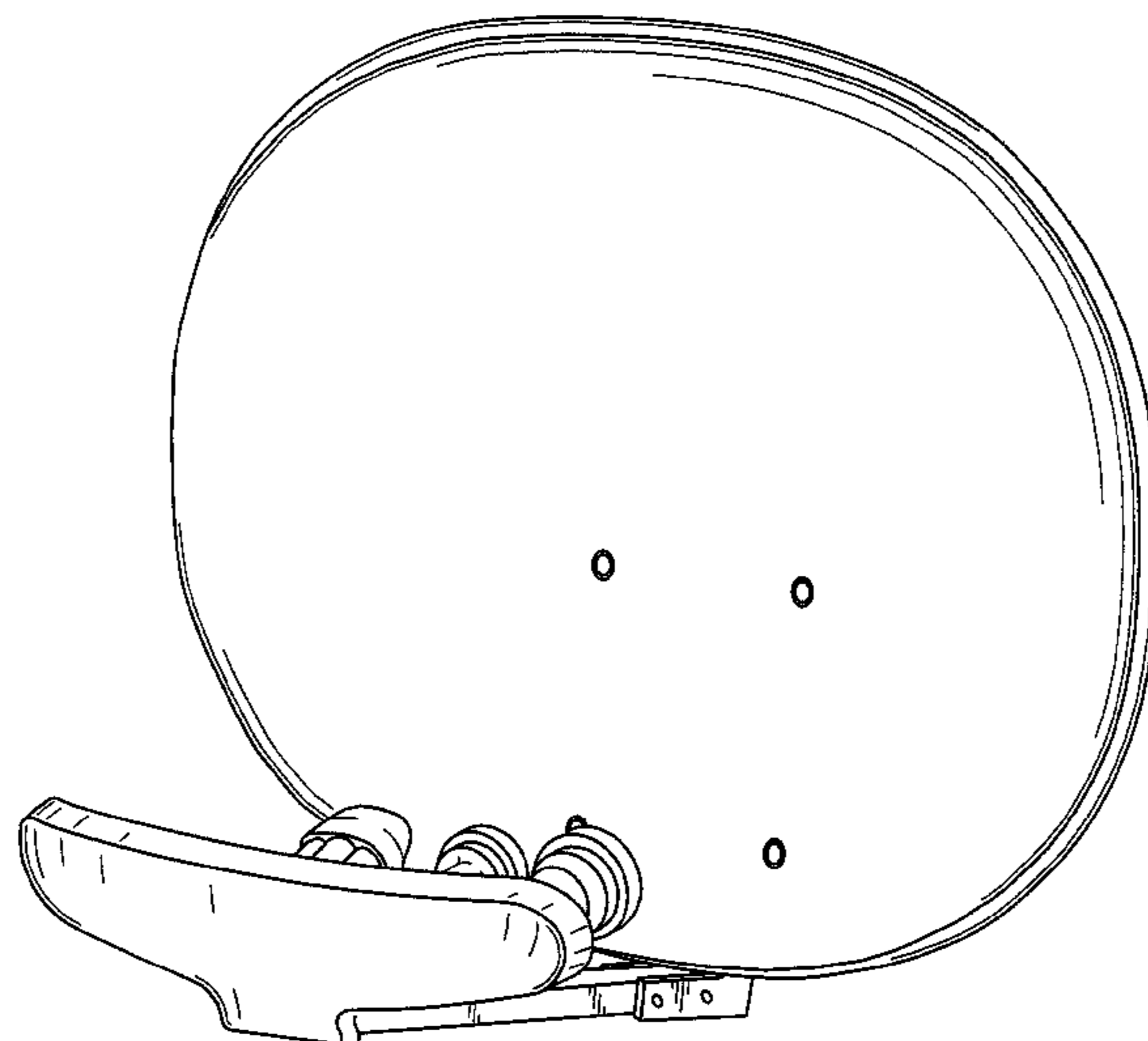

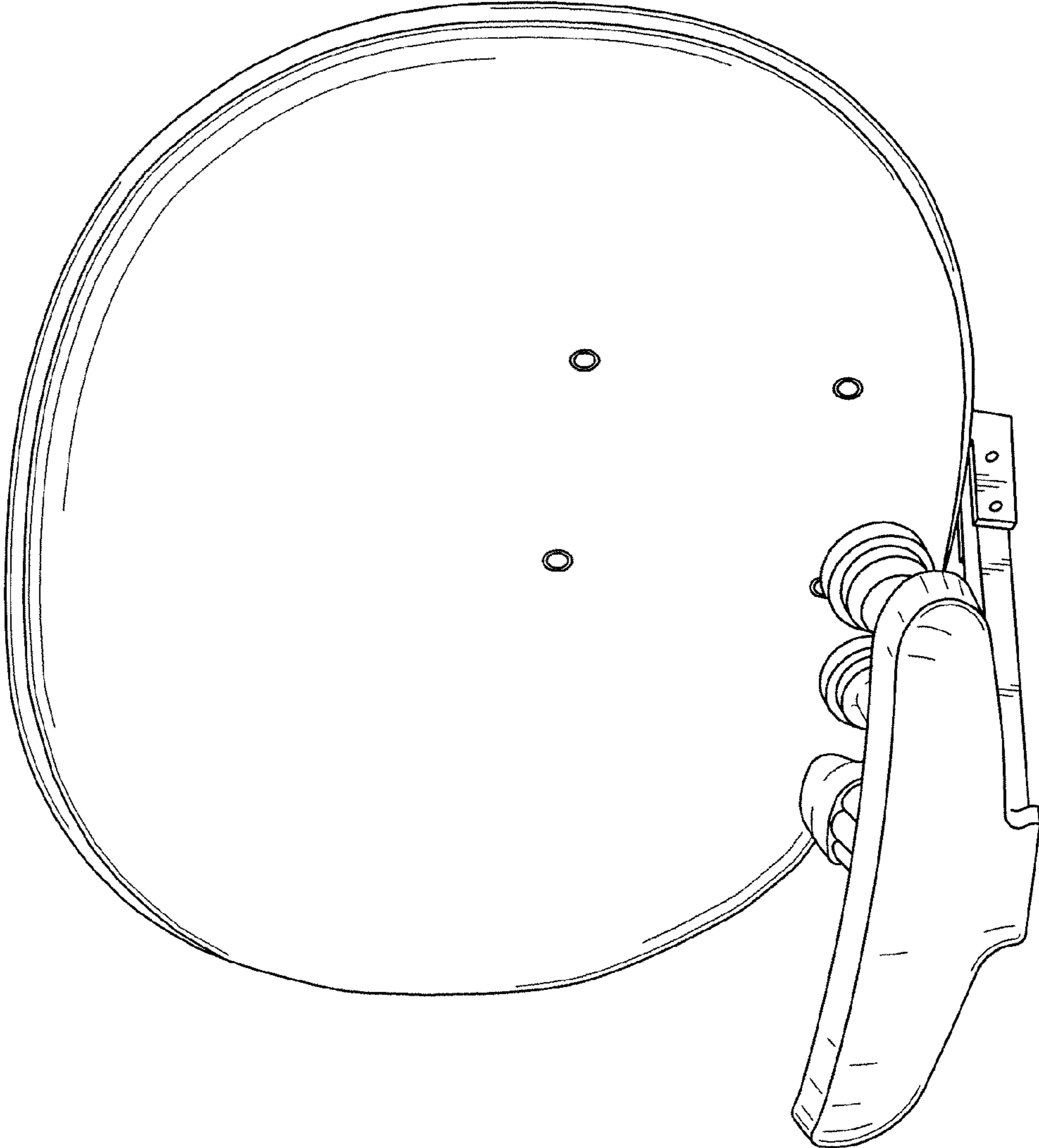

FIG. 1

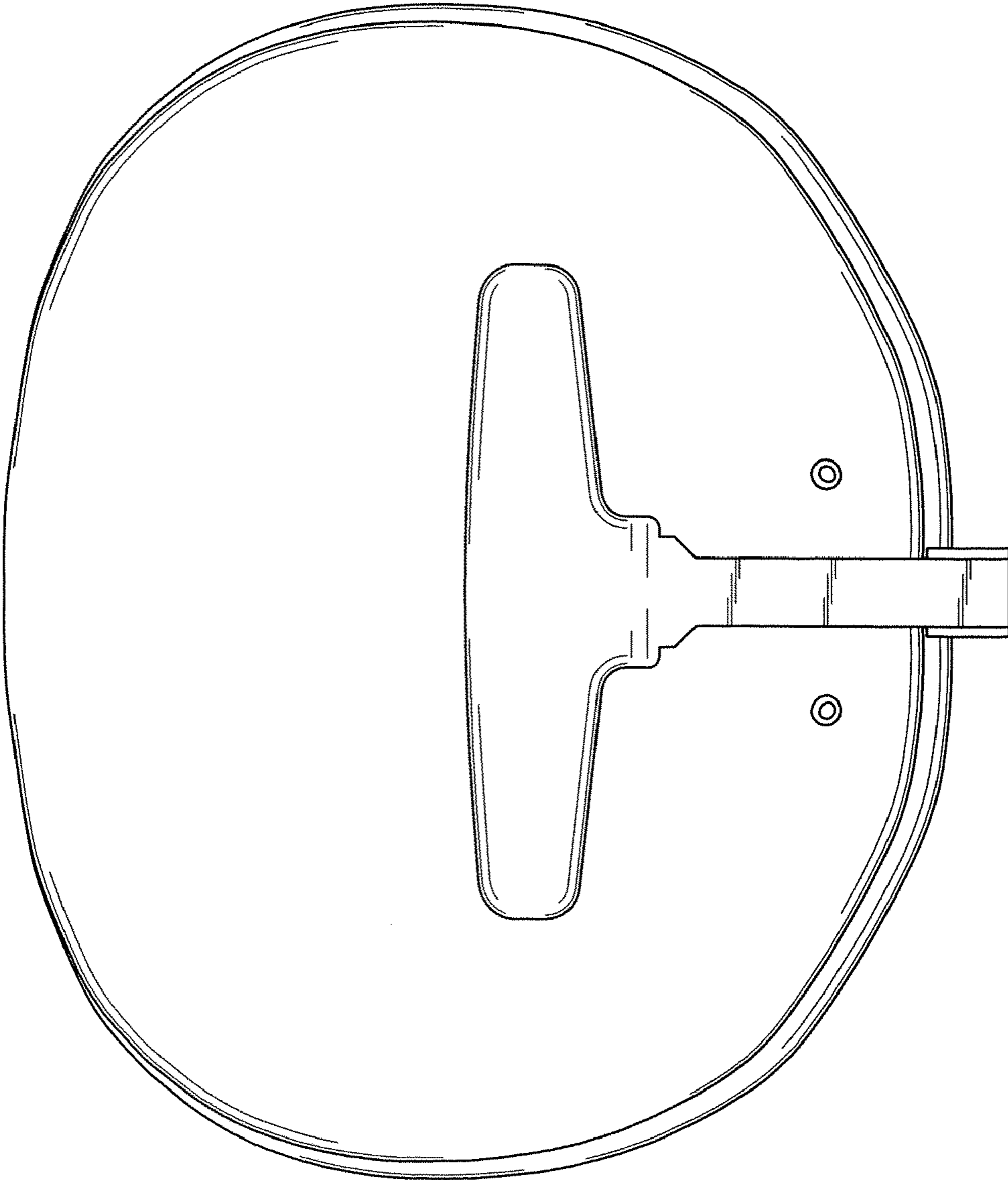

FIG. 2

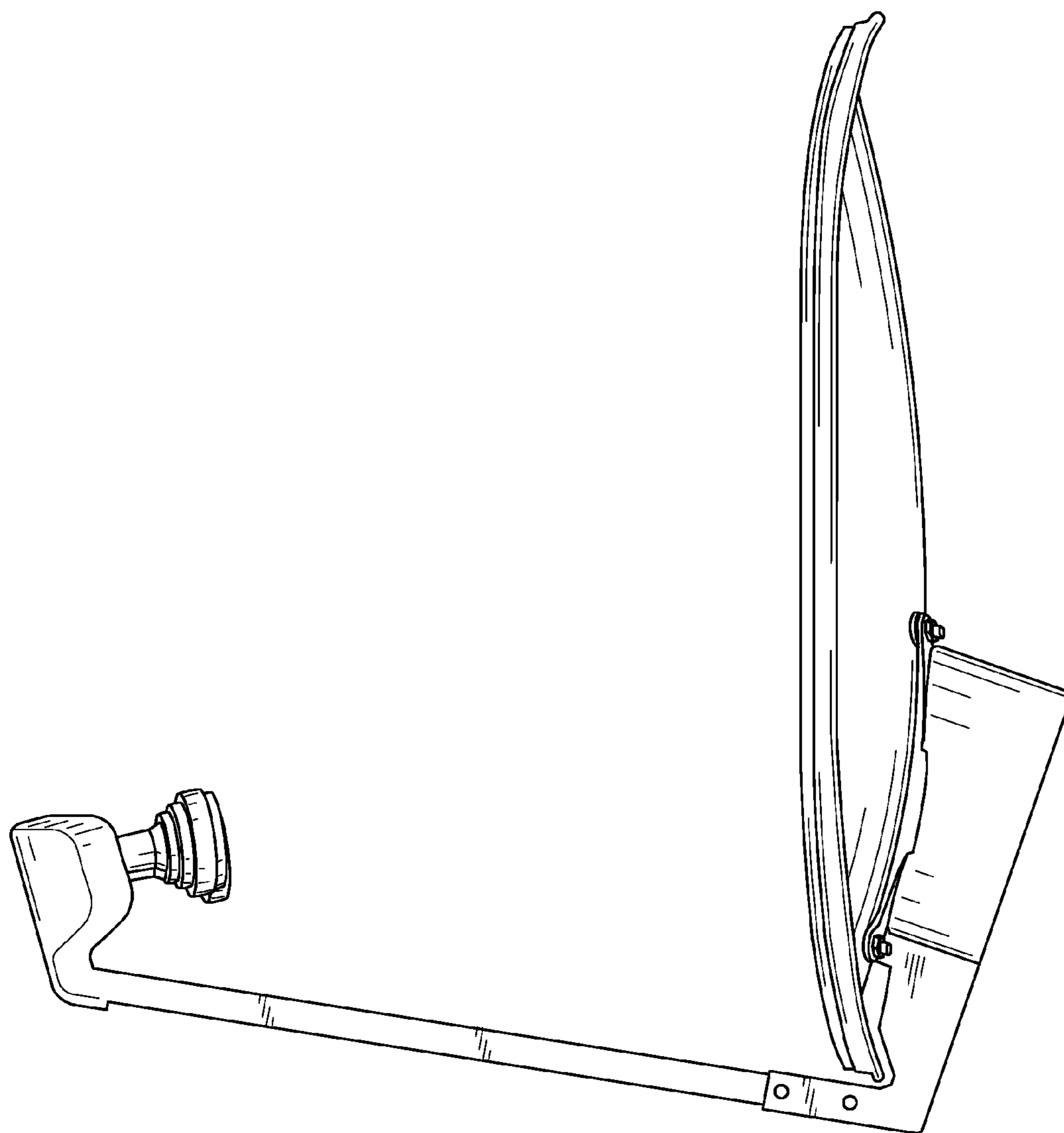

FIG. 3

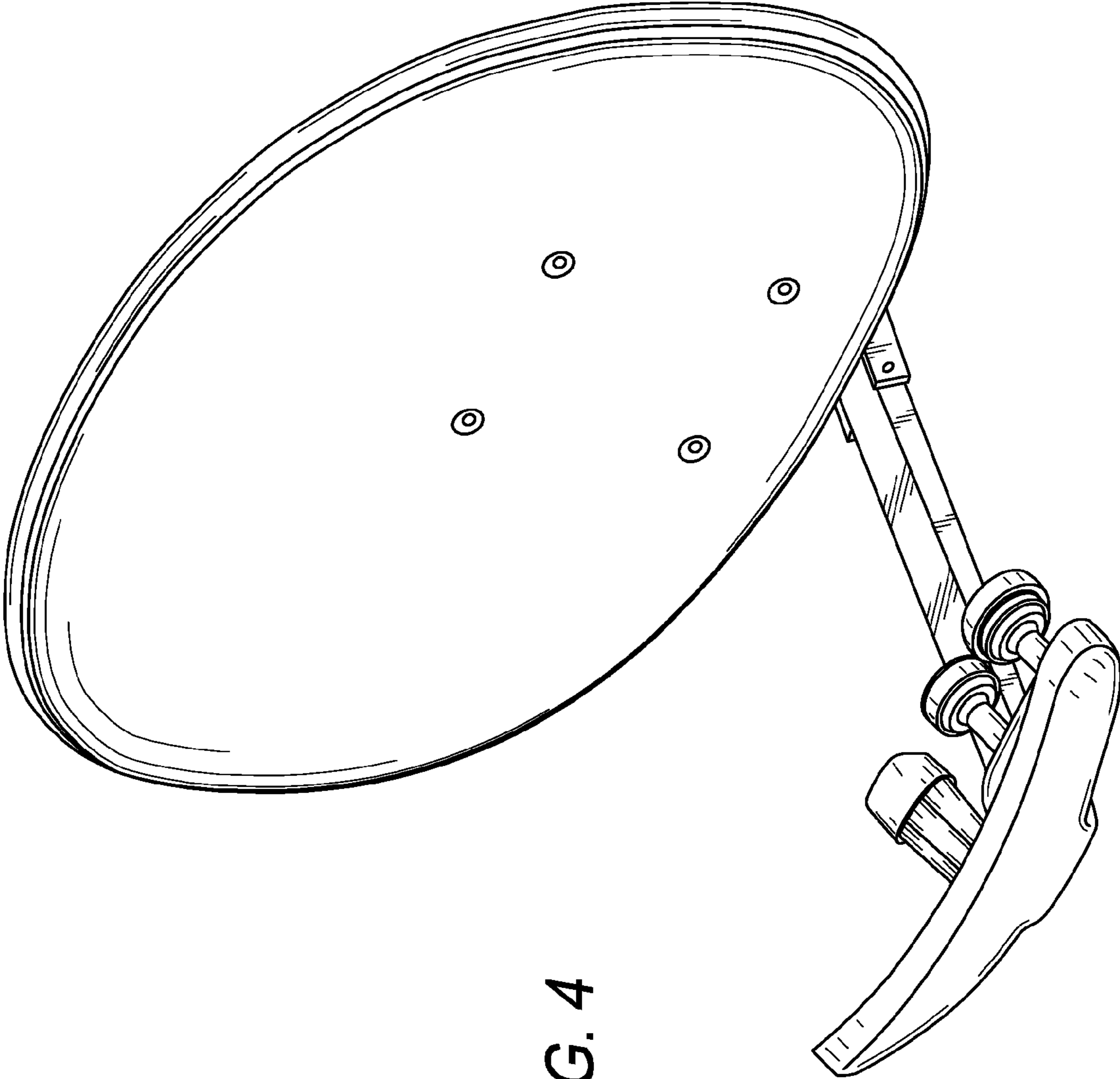

FIG. 4

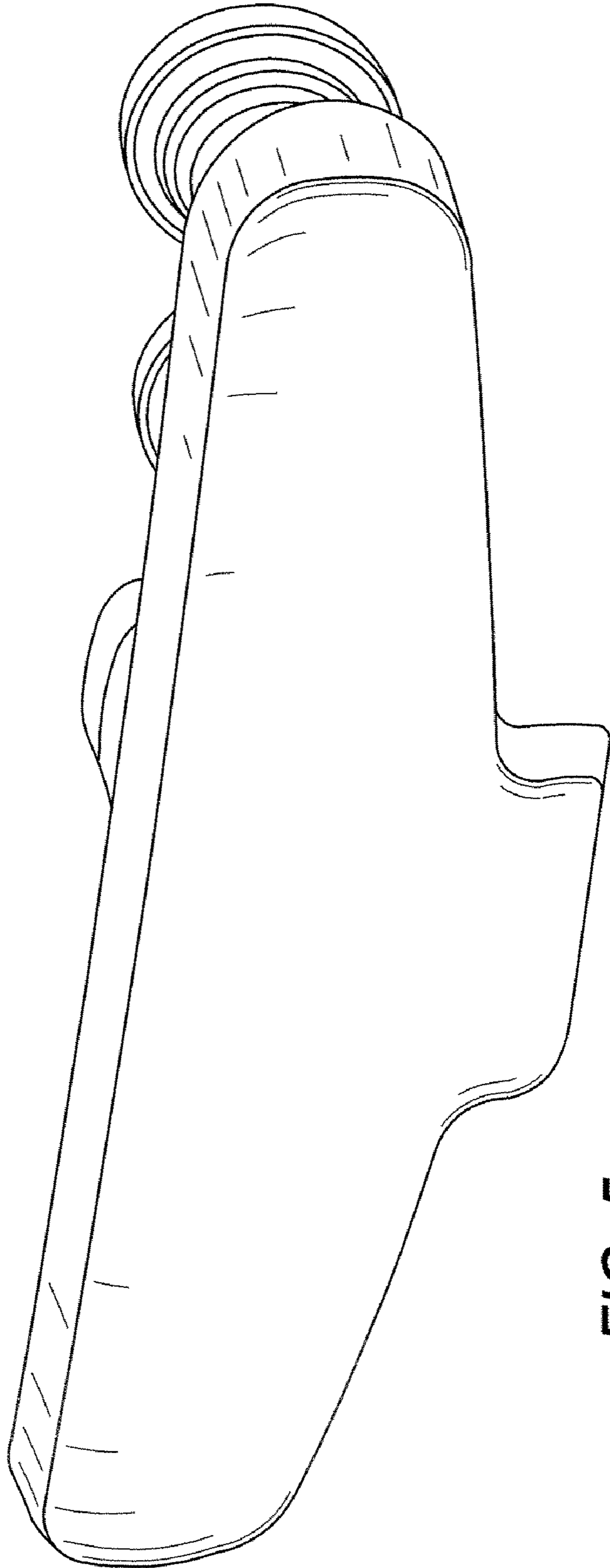

FIG. 5

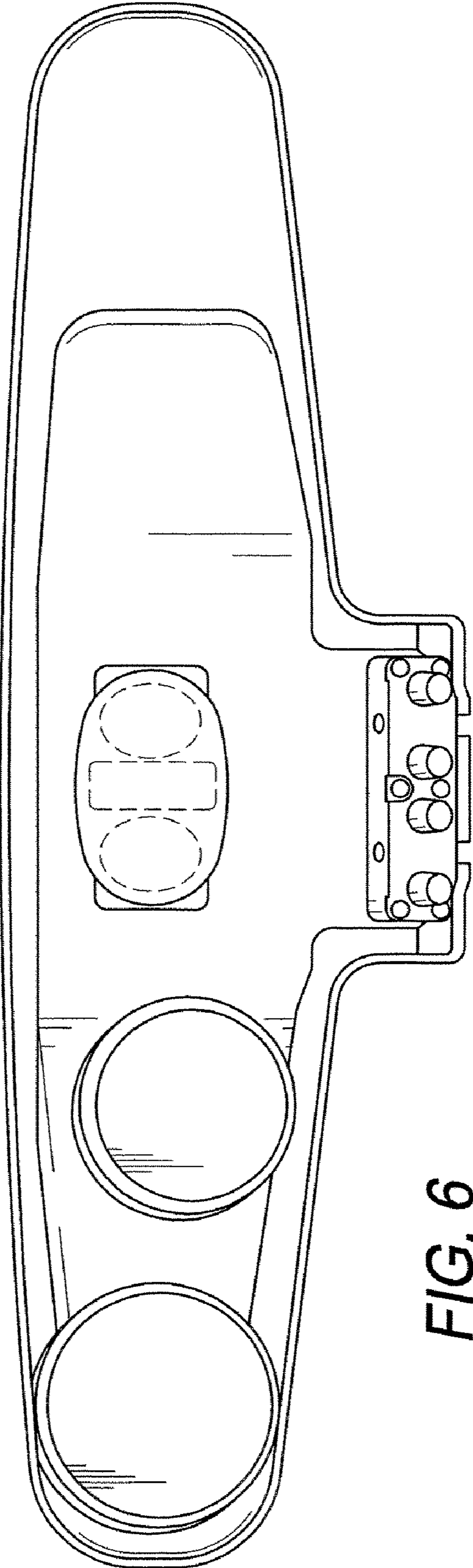

FIG. 6

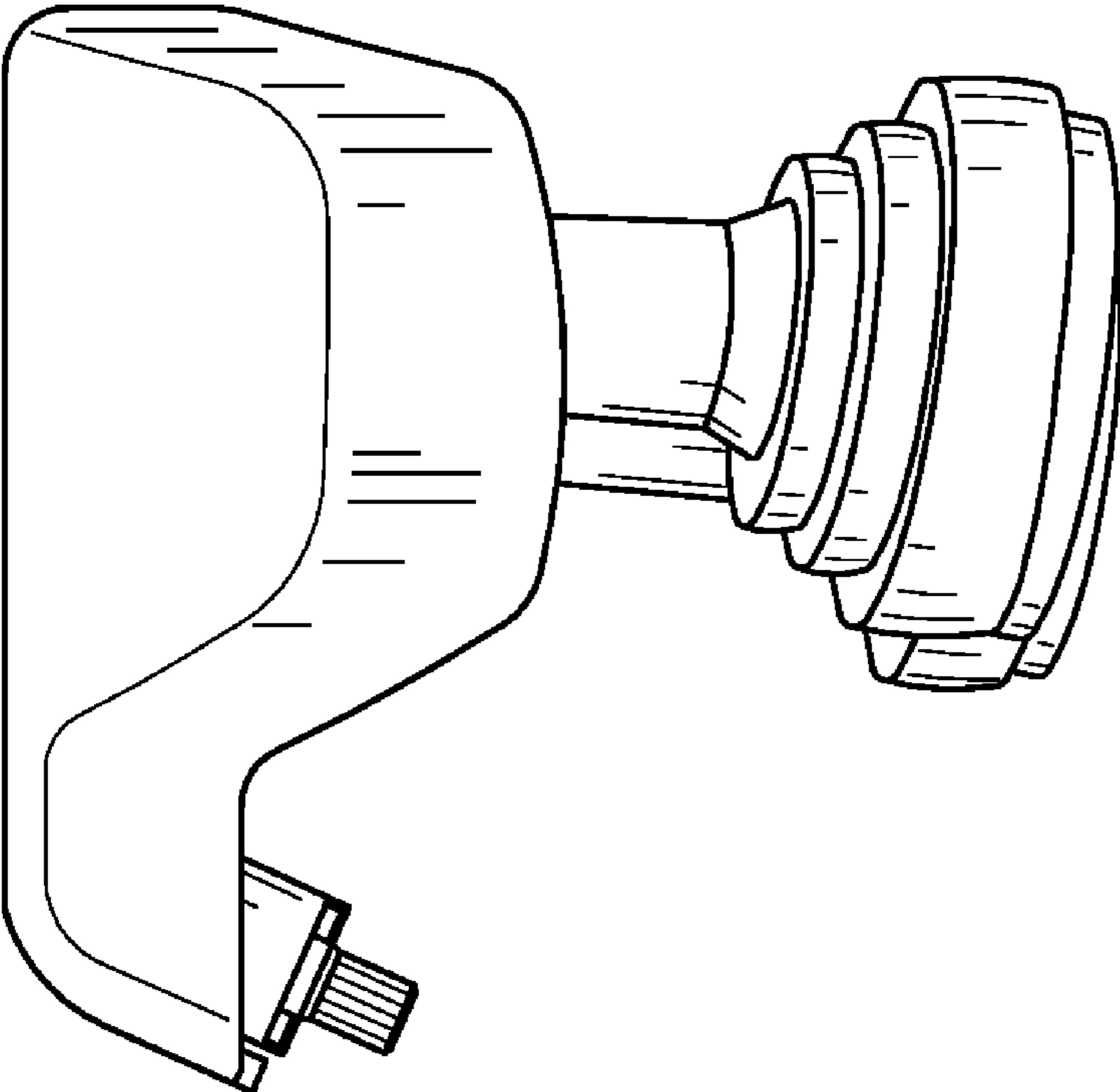

FIG. 7

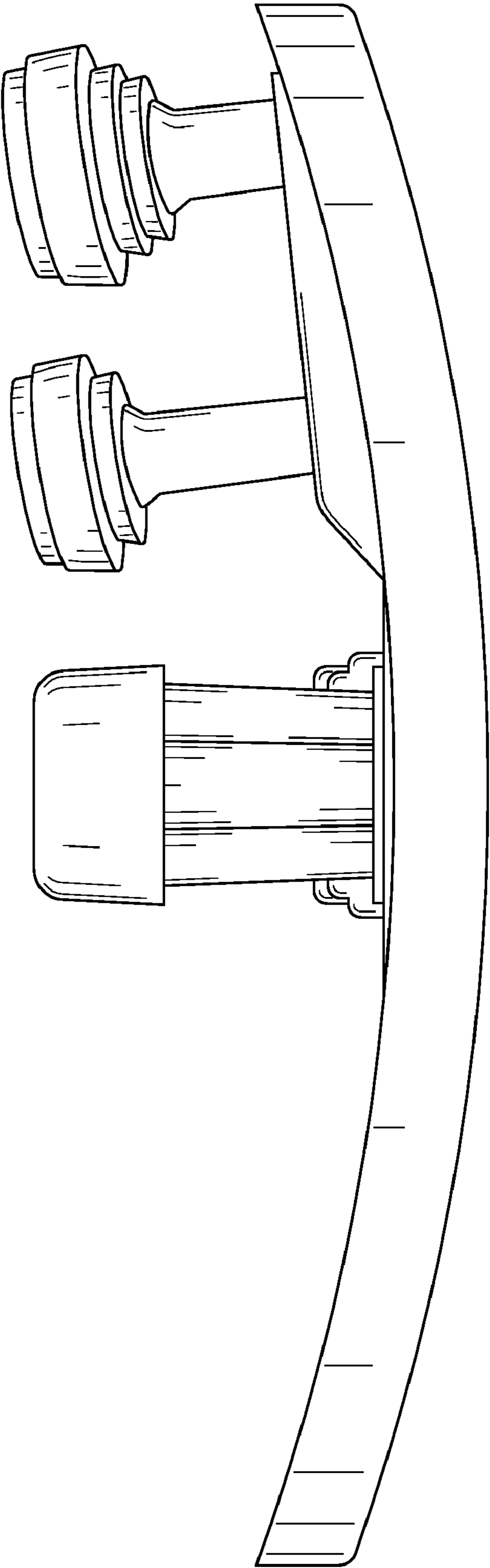

FIG. 8