



US00D598129S

(12) **United States Design Patent**  
**Tsukuda et al.**

(10) **Patent No.:** **US D598,129 S**

(45) **Date of Patent:** **\*\* Aug. 11, 2009**

(54) **SPECIMEN PREPARING APPARATUS**

(75) Inventors: **Masabumi Tsukuda**, Chiba (JP);  
**Yukimitsu Kijima**, Chiba (JP)

(73) Assignee: **Seiko Instruments Inc.**, Chiba (JP)

(\*\*) Term: **14 Years**

(21) Appl. No.: **29/309,948**

(22) Filed: **Nov. 19, 2008**

(30) **Foreign Application Priority Data**

May 20, 2008 (JP) ..... 2008-012551

(51) **LOC (9) Cl.** ..... **24-02**

(52) **U.S. Cl.** ..... **D24/234**

(58) **Field of Classification Search** ..... D24/107-109,  
D24/156, 186, 231-232, 234; D10/81; 422/50,  
422/63, 68.1, 73, 81; 435/283.1

See application file for complete search history.

(56) **References Cited**

**U.S. PATENT DOCUMENTS**

D245,352 S \* 8/1977 Moran ..... D10/81  
D319,307 S \* 8/1991 Sakagami et al. .... D24/232  
D320,073 S \* 9/1991 Sakagami et al. .... D24/232  
D320,443 S \* 10/1991 Yokoyama et al. .... D24/231  
D333,007 S \* 2/1993 LaBarbera ..... D24/216  
D338,962 S \* 8/1993 Ikegami et al. .... D24/186  
D346,027 S \* 4/1994 Kobayashi ..... D24/186  
D349,861 S \* 8/1994 Kanewske et al. .... D10/81  
D369,564 S \* 5/1996 Whitby et al. .... D24/234

D404,816 S \* 1/1999 Tsuan ..... D24/186  
D410,080 S \* 5/1999 Heidsiek et al. .... D24/107  
D512,155 S \* 11/2005 Matsumoto ..... D24/216

\* cited by examiner

*Primary Examiner*—T. Chase Nelson

*Assistant Examiner*—Mark Cavanna

(74) *Attorney, Agent, or Firm*—Finnegan, Henderson,  
Farabow, Garrett & Dunner, L.L.P.

(57) **CLAIM**

The ornamental design for a specimen preparing apparatus, as shown and described.

**DESCRIPTION**

FIG. 1 is a perspective view of the top, front and right side of a specimen preparing apparatus showing our new design;

FIG. 2 is a front view thereof;

FIG. 3 is a rear view thereof;

FIG. 4 is a top plan view thereof;

FIG. 5 is a bottom view thereof;

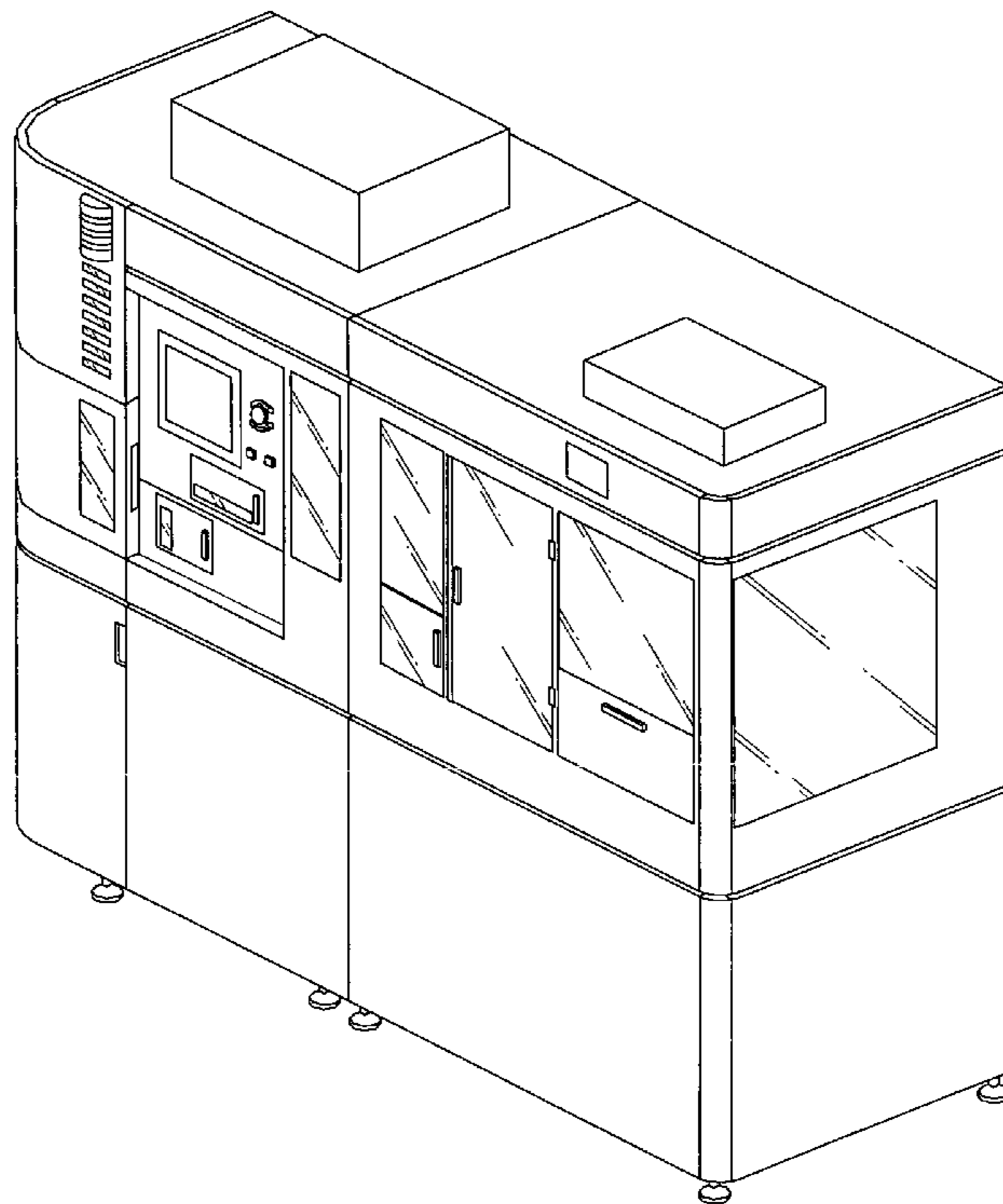
FIG. 6 is a left side view thereof;

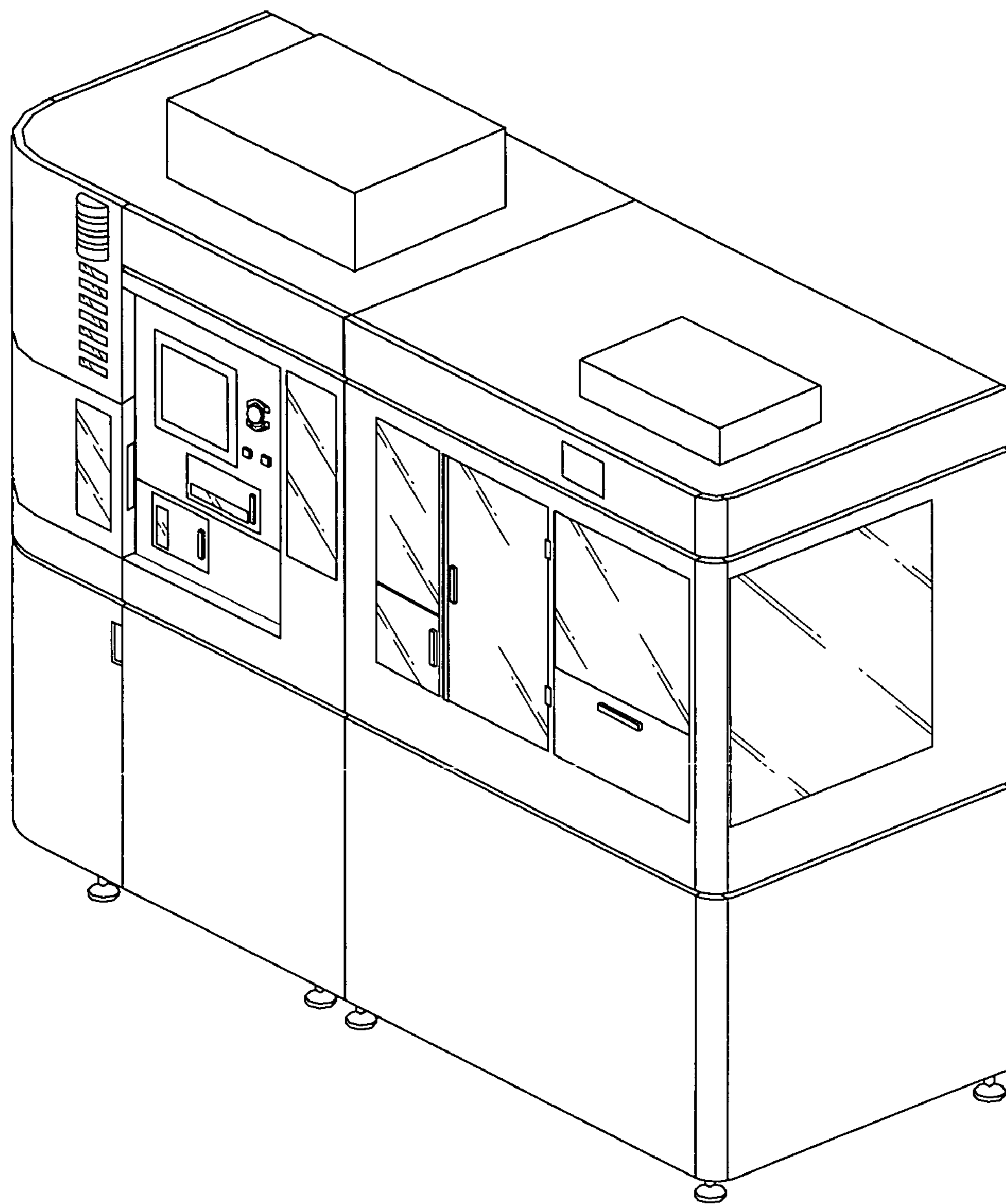
FIG. 7 is a right side view thereof; and,

FIG. 8 is a perspective reference view with the lid in open condition thereof.

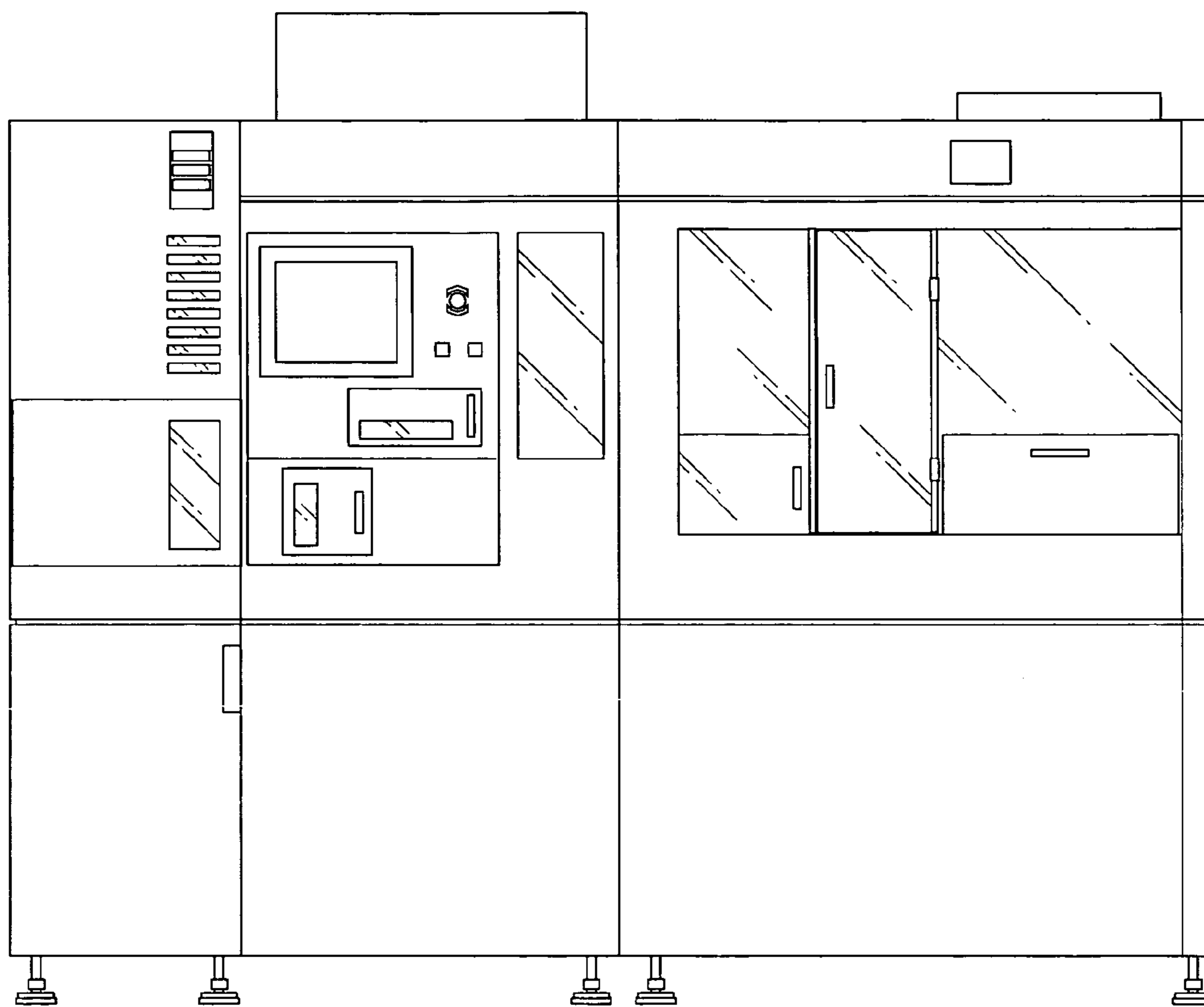
The broken lines shown in the interior of specimen preparing apparatus in FIG. 8 are included for the purpose of illustrating a portion of the specimen preparing apparatus that forms no part of the claimed design.

**1 Claim, 6 Drawing Sheets**

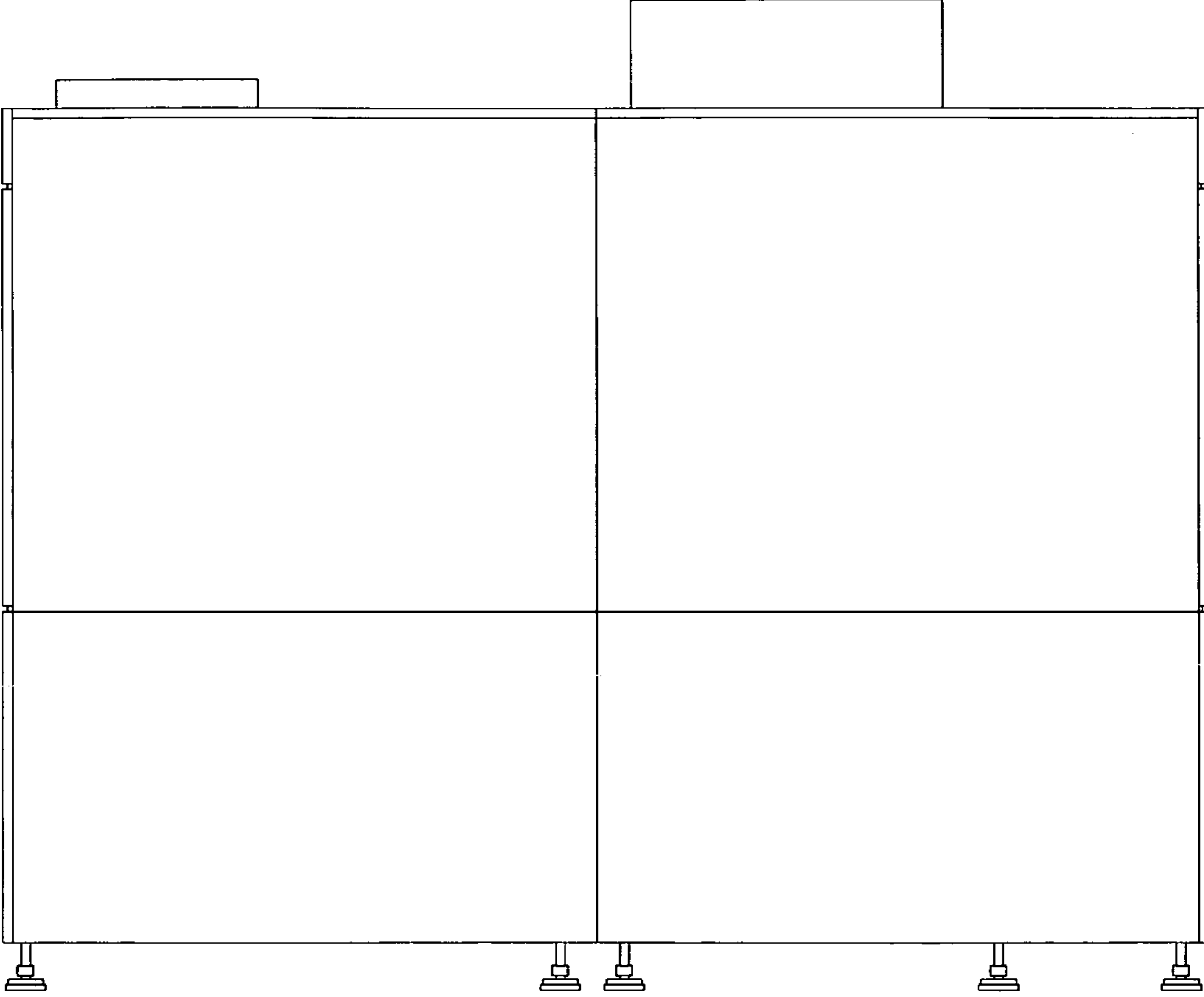




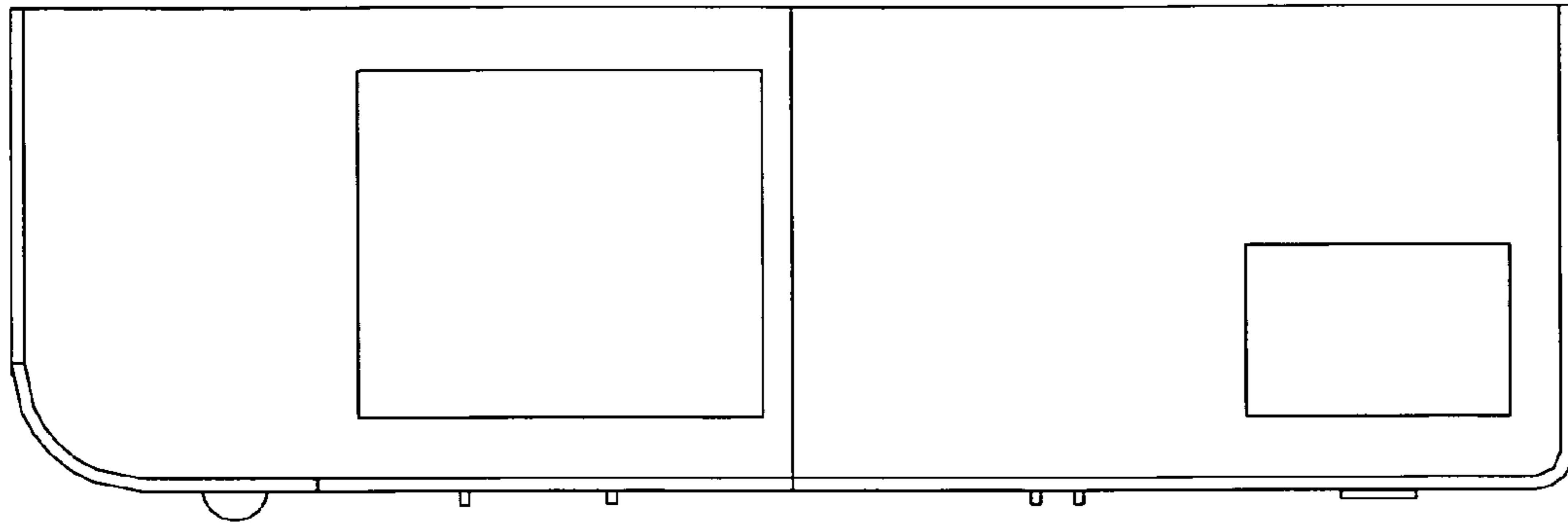
**FIG. 1**



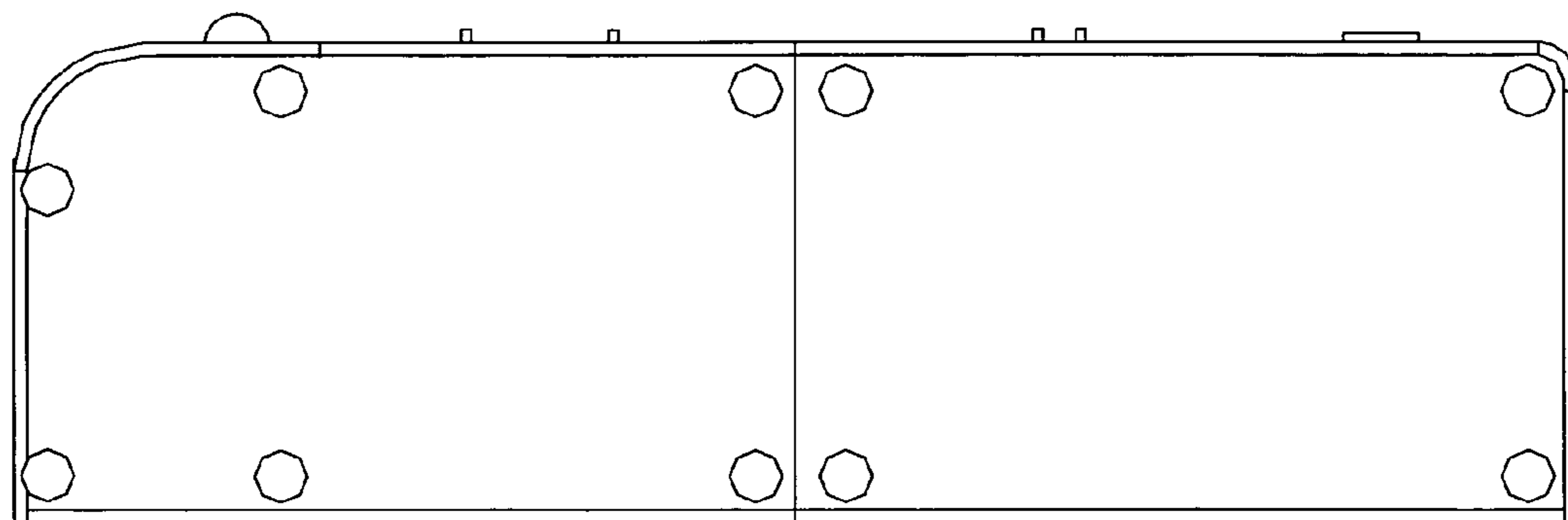
**FIG. 2**



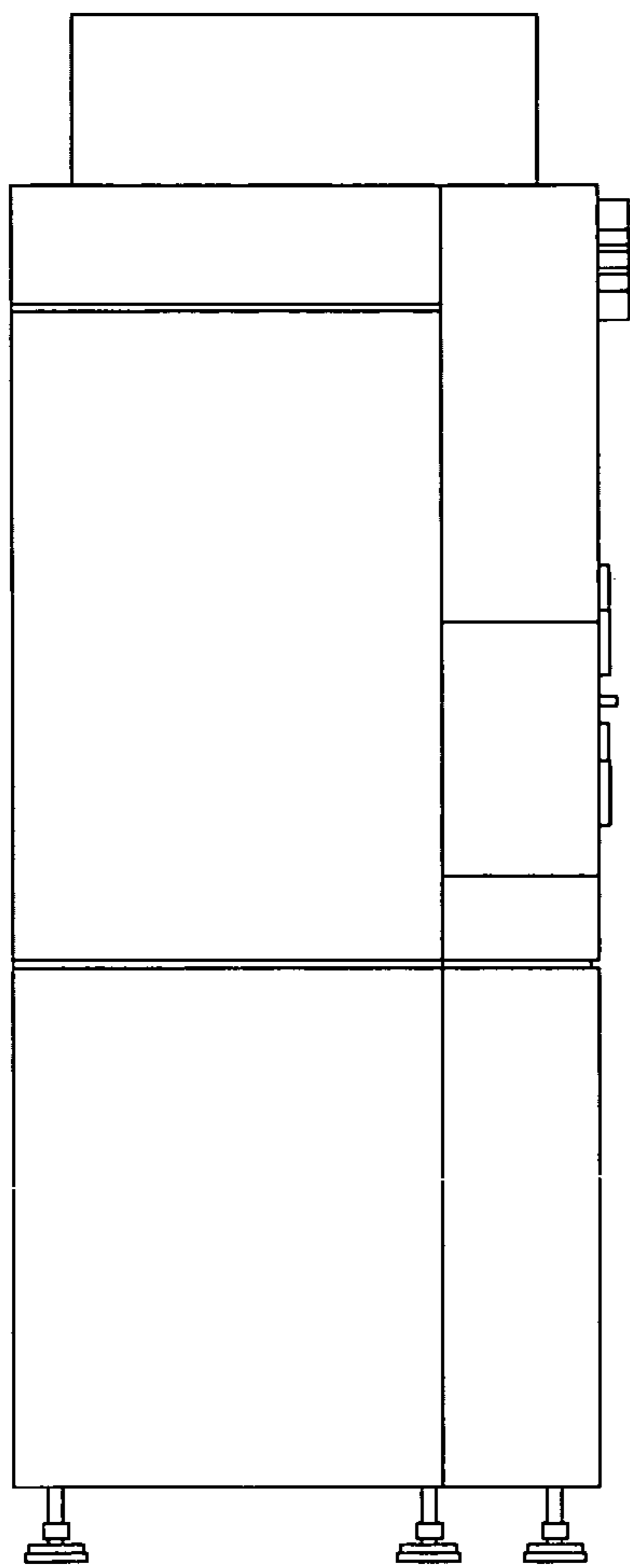
**FIG. 3**



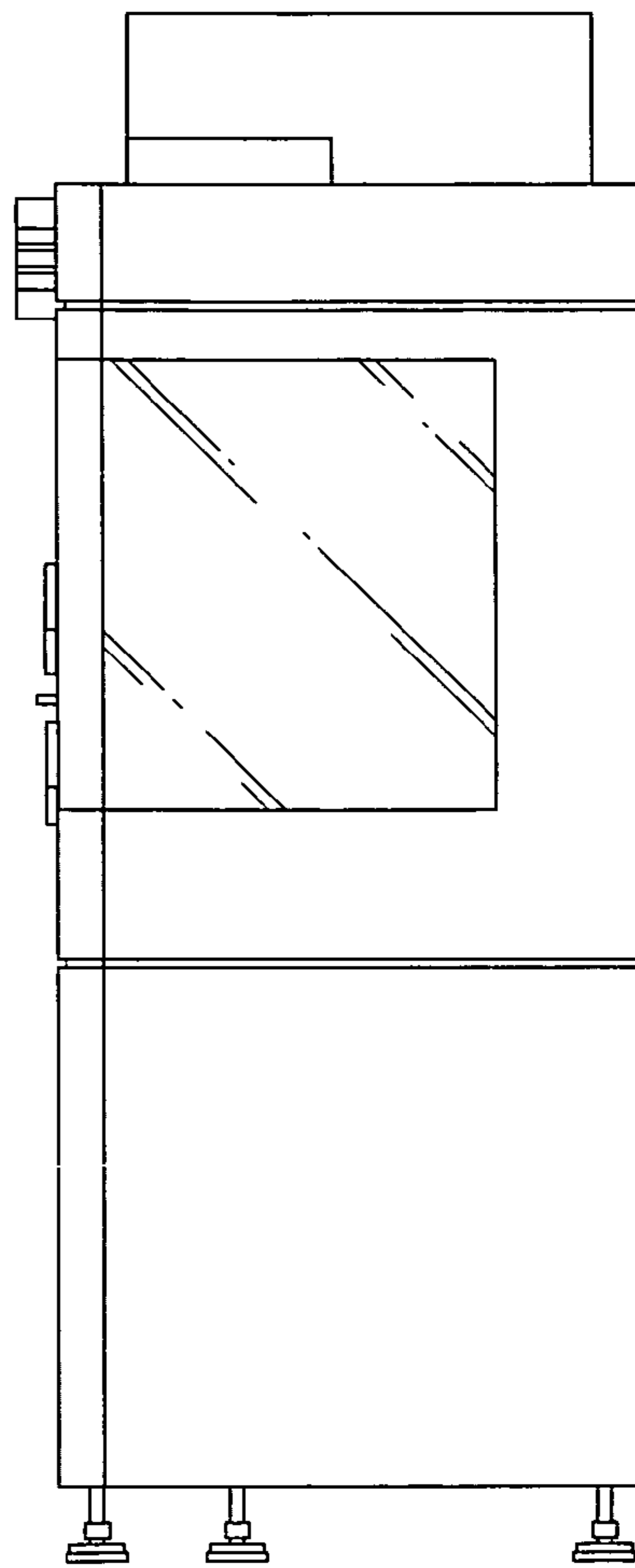
**FIG. 4**



**FIG. 5**



*FIG. 6*



*FIG. 7*

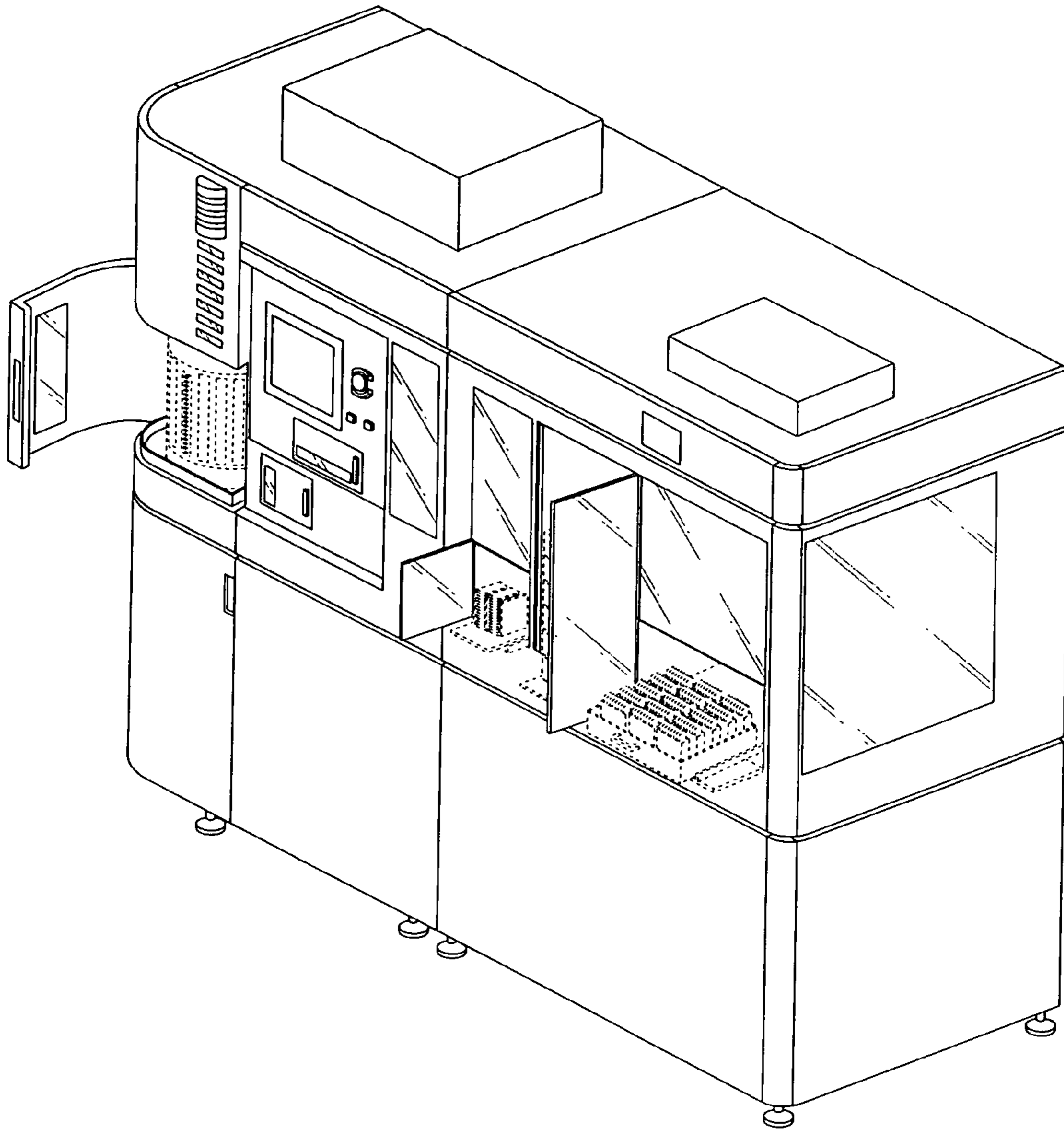


FIG. 8