



US00D598030S

(12) **United States Design Patent**  
**Schell et al.**

(10) **Patent No.:** **US D598,030 S**

(45) **Date of Patent:** **\*\* Aug. 11, 2009**

(54) **UTILITY VEHICLE**

(75) Inventors: **Oliver Schell**, Aachen (DE);  
**Franz-Josef Schell**, Aachen (DE)

(73) Assignee: **Schell GmbH Grüntechnik**, Aachen (DE)

(\*\*) Term: **14 Years**

(21) Appl. No.: **29/266,889**

(22) Filed: **Sep. 29, 2006**

(30) **Foreign Application Priority Data**

Apr. 6, 2006 (EM) ..... 000509286

(51) **LOC (9) Cl.** ..... **15-03**

(52) **U.S. Cl.** ..... **D15/22; D15/10**

(58) **Field of Classification Search** ..... D15/10,  
D15/22-26, 28, 30-33; D12/14-16, 1, 96;  
296/190.01, 190.08, 183.1, 183.2; 280/DIG. 5;  
180/89.1, 89.12, 900

See application file for complete search history.

(56) **References Cited**

**U.S. PATENT DOCUMENTS**

3,765,553	A *	10/1973	Schaeff	.....	414/694
D297,539	S *	9/1988	Morita et al.	.....	D15/23
D306,170	S *	2/1990	Takagi et al.	.....	D15/23
D315,325	S *	3/1991	Legueu	.....	D12/96
5,199,861	A *	4/1993	Merlo et al.	.....	414/718
D345,741	S *	4/1994	Mullett et al.	.....	D15/23
D353,704	S *	12/1994	Bhambra	.....	D34/37
5,468,120	A *	11/1995	Krob	.....	414/695
5,778,569	A *	7/1998	Schaeff	.....	37/410

\* cited by examiner

*Primary Examiner*—Stella M Reid

*Assistant Examiner*—Mark A Goodwin

(74) *Attorney, Agent, or Firm*—Cohen Pontani Lieberman & Pavane LLP

(57) **CLAIM**

The ornamental design for a utility vehicle, as shown and described.

**DESCRIPTION**

FIG. 1 is a rear view of a utility vehicle showing our new design;

FIG. 2 is a right side view of the utility vehicle in accordance with the design;

FIG. 3 is a left side view of the utility vehicle in accordance with the design;

FIG. 4 is a front view of the utility vehicle in accordance with the design;

FIG. 5 is a front perspective view of the utility vehicle in accordance with the invention; and,

FIG. 6 is a front left perspective of the utility vehicle in accordance with the design.

Applicants disclaim the top and bottom of the utility vehicle not shown in the drawing as forming no part of the claimed design.

Applicants also disclaim all alphanumeric and associated indicia on the utility vehicle as forming no part of the claimed design.

The broken line showing of the tire treads, roof top light, and connection points of the front of the vehicle is included for the purpose of illustrating portions of the utility vehicle and forms no part of the claimed design.

**1 Claim, 6 Drawing Sheets**

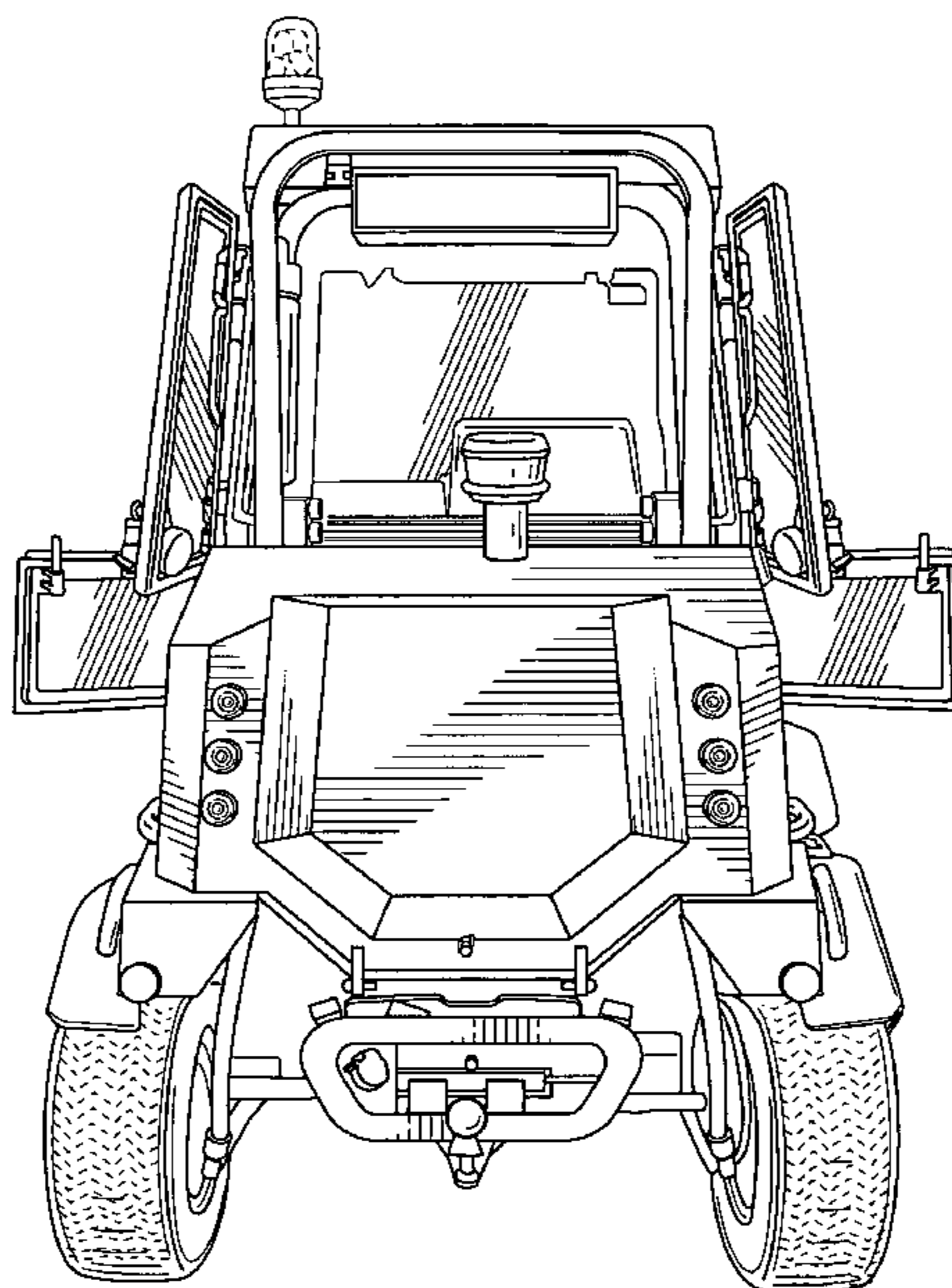

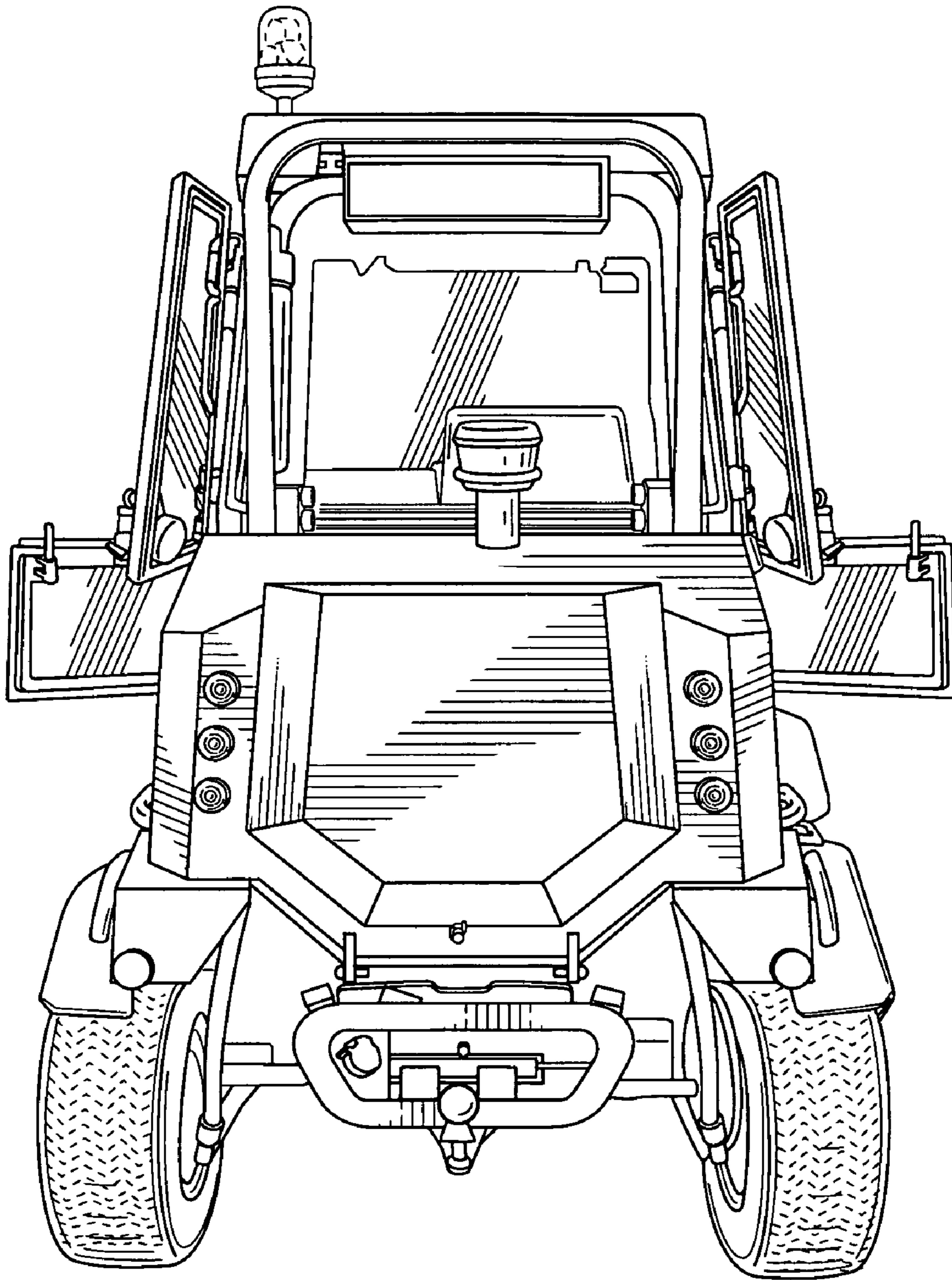

**FIG. 1**

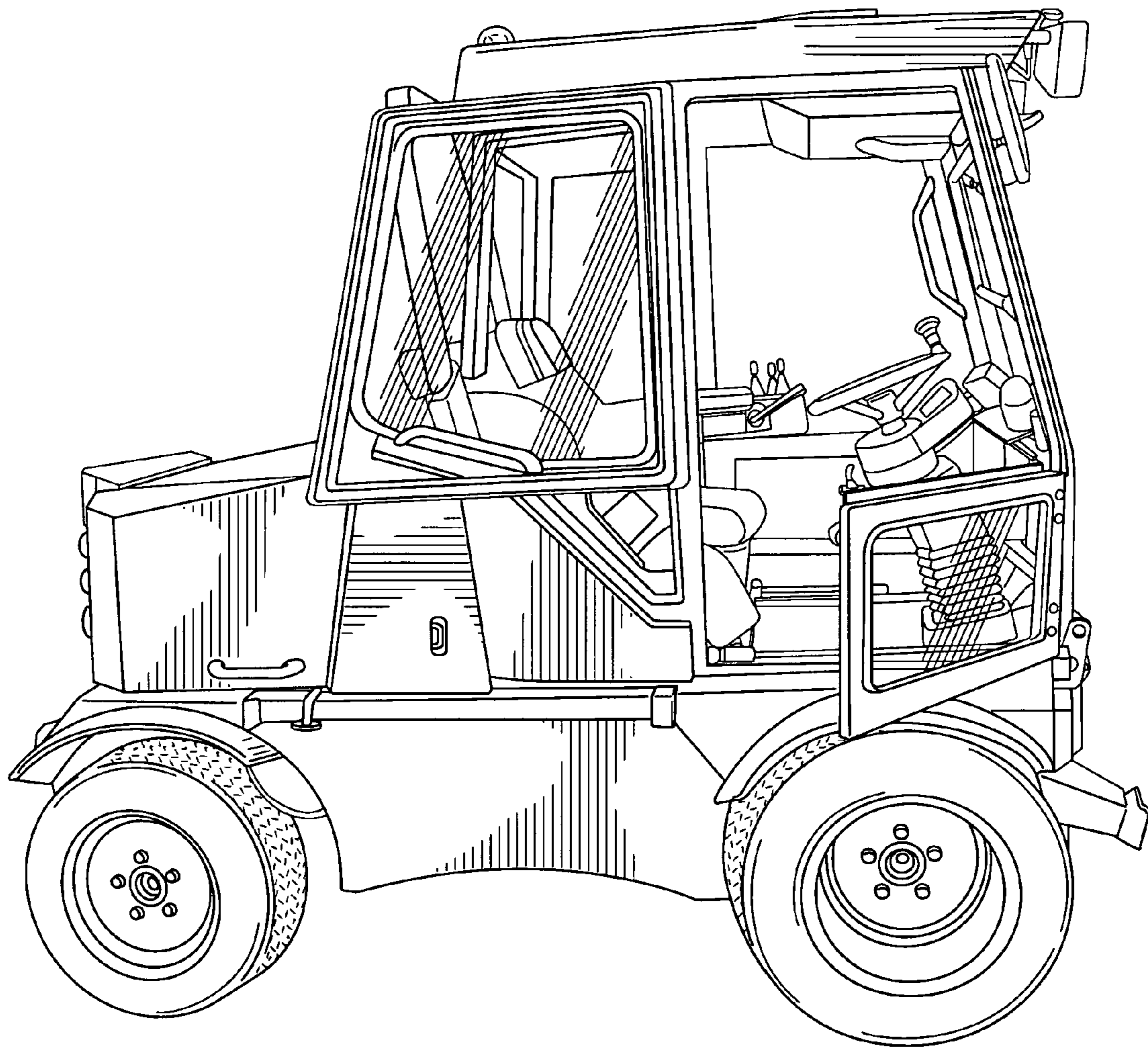

FIG. 2

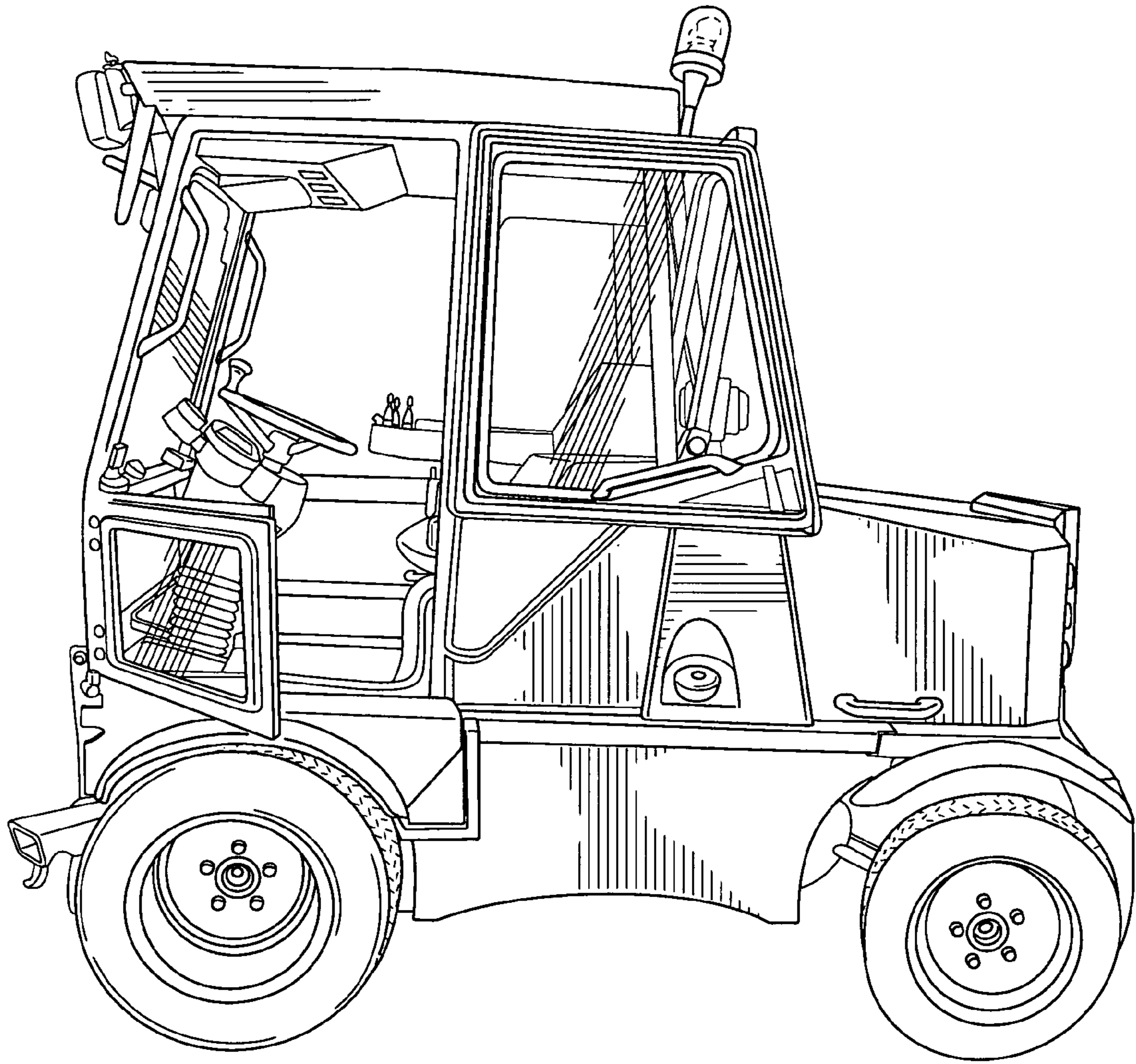

FIG. 3

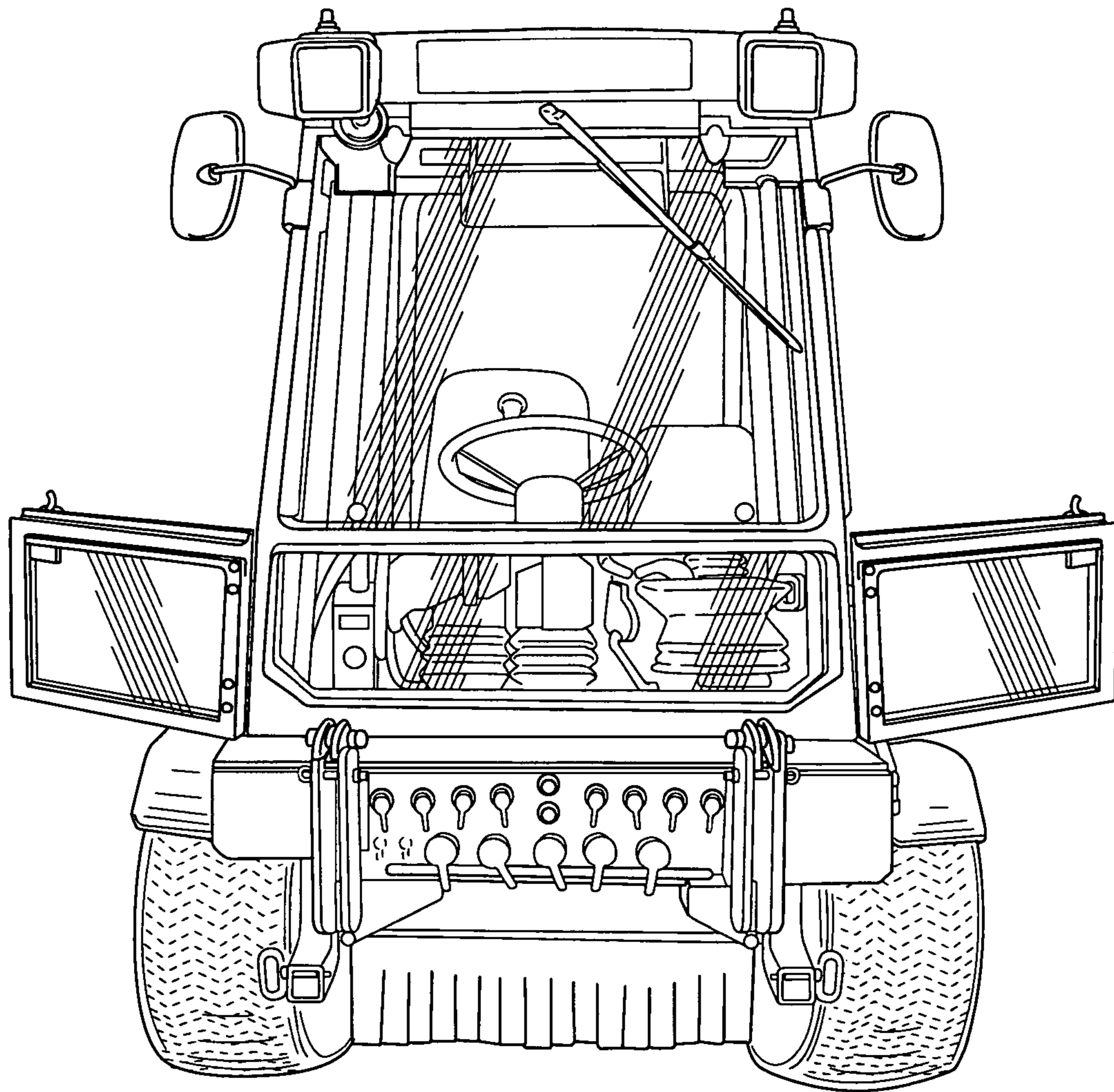
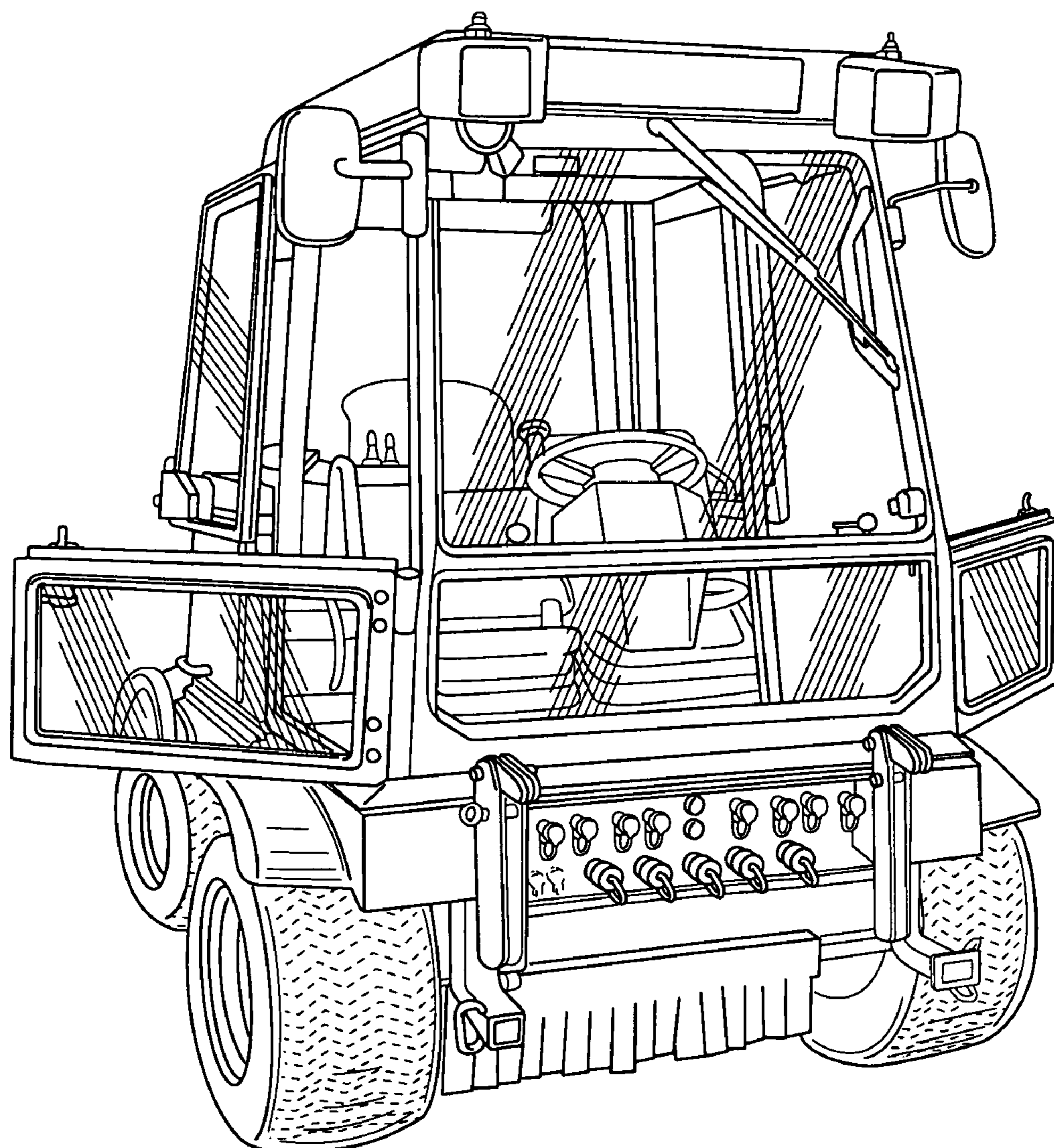
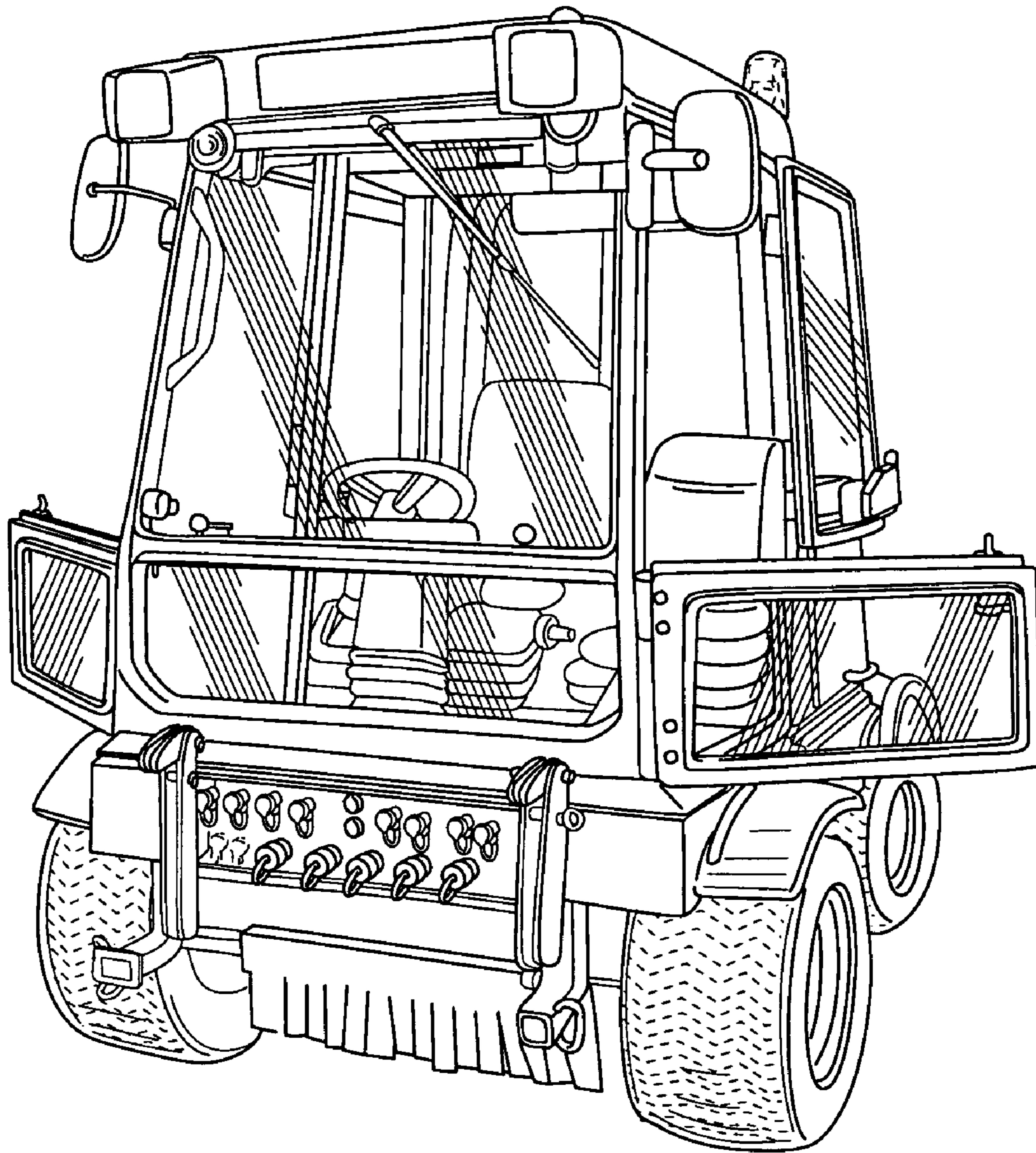

FIG. 4



**FIG. 5**



**FIG. 6**