



US00D597950S

(12) **United States Design Patent**
Suzuki et al.

(10) **Patent No.:** **US D597,950 S**
(45) **Date of Patent:** **** Aug. 11, 2009**

(54) **TUNER**

(75) Inventors: **Takumi Suzuki**, Akita (JP); **Toshihiko Inaba**, Akita (JP); **Naoto Kondo**, Akita (JP); **Kyuichi Sato**, Akita (JP)

(73) Assignee: **Mitsumi Electric Co., Ltd.**, Tama-shi (JP)

(**) Term: **14 Years**

(21) Appl. No.: **29/282,131**

(22) Filed: **Jul. 12, 2007**

(30) **Foreign Application Priority Data**

Jan. 15, 2007 (JP) 2007-000507

(51) **LOC (9) Cl.** **13-03**

(52) **U.S. Cl.** **D13/147**

(58) **Field of Classification Search** D13/133,
D13/146-147, 154, 184; D14/188, 230;
439/64, 79, 72, 246, 259, 278, 607-610,
439/862, 891, 894

See application file for complete search history.

(56) **References Cited**

U.S. PATENT DOCUMENTS

6,773,308 B2 * 8/2004 Lwee 439/630
D518,815 S * 4/2006 Otani D14/188

D533,508 S * 12/2006 Suzuki et al. D13/147
D556,734 S * 12/2007 Otani D14/188
2005/0162242 A1 * 7/2005 Ootori et al. 334/85
2007/0178873 A1 * 8/2007 Inaba et al. 455/340

* cited by examiner

Primary Examiner—Daniel D Bui

(74) *Attorney, Agent, or Firm*—Sughrue Mion, PLLC

(57) **CLAIM**

The ornamental design for a tuner, as shown and described.

DESCRIPTION

FIG. 1 is a perspective view of the top, front and right side of a tuner showing our new design;

FIG. 2 is a front elevational view thereof;

FIG. 3 is a rear elevational view thereof;

FIG. 4 is a right side elevational view thereof;

FIG. 5 is a left side elevational view thereof;

FIG. 6 is a top plan view thereof;

FIG. 7 is a bottom plan view thereof; and,

FIG. 8 is a perspective view of the bottom, rear and left side thereof.

The broken lines in the figures are intended to show environmental structure only, and form no part of the claimed design.

1 Claim, 6 Drawing Sheets

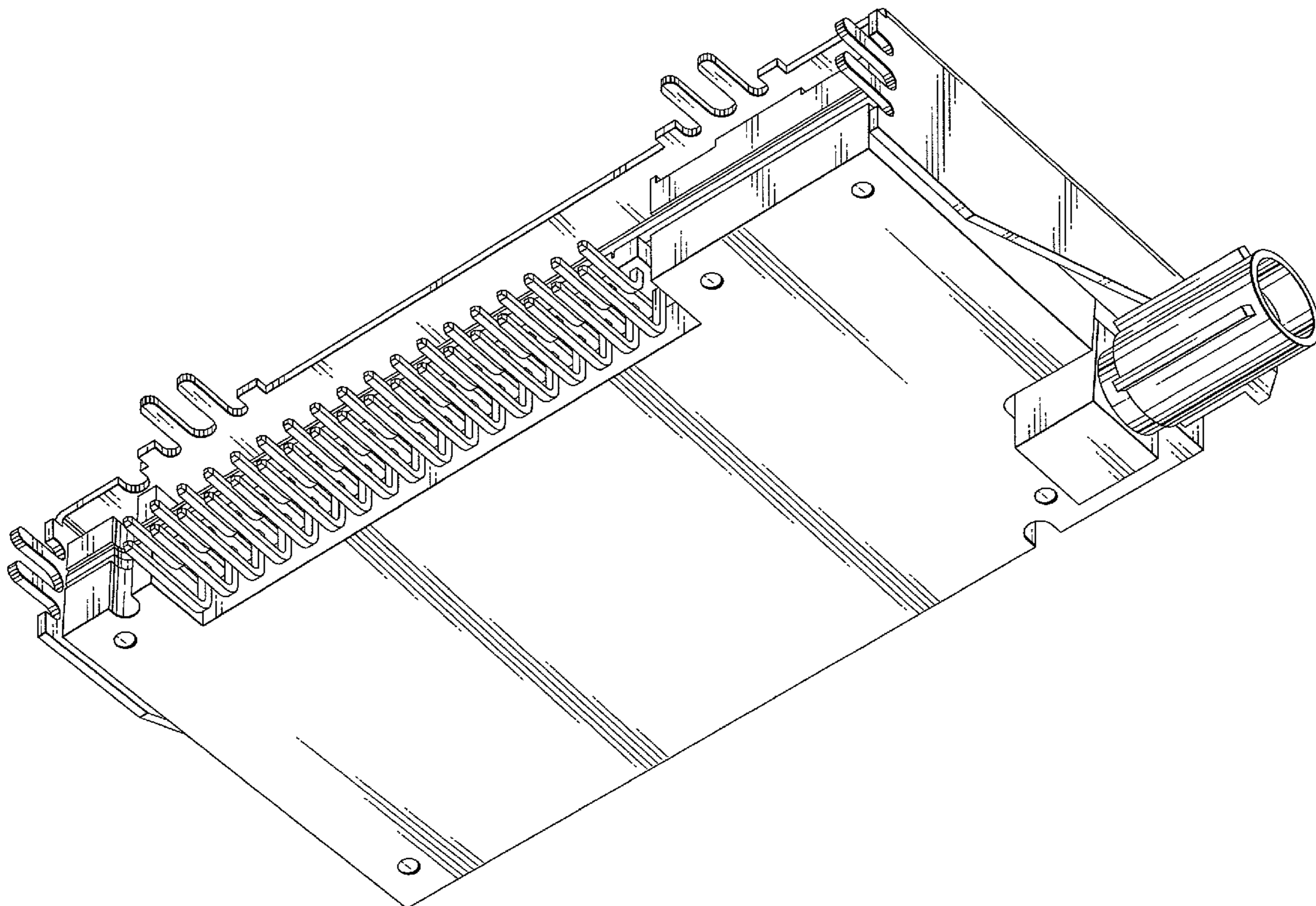

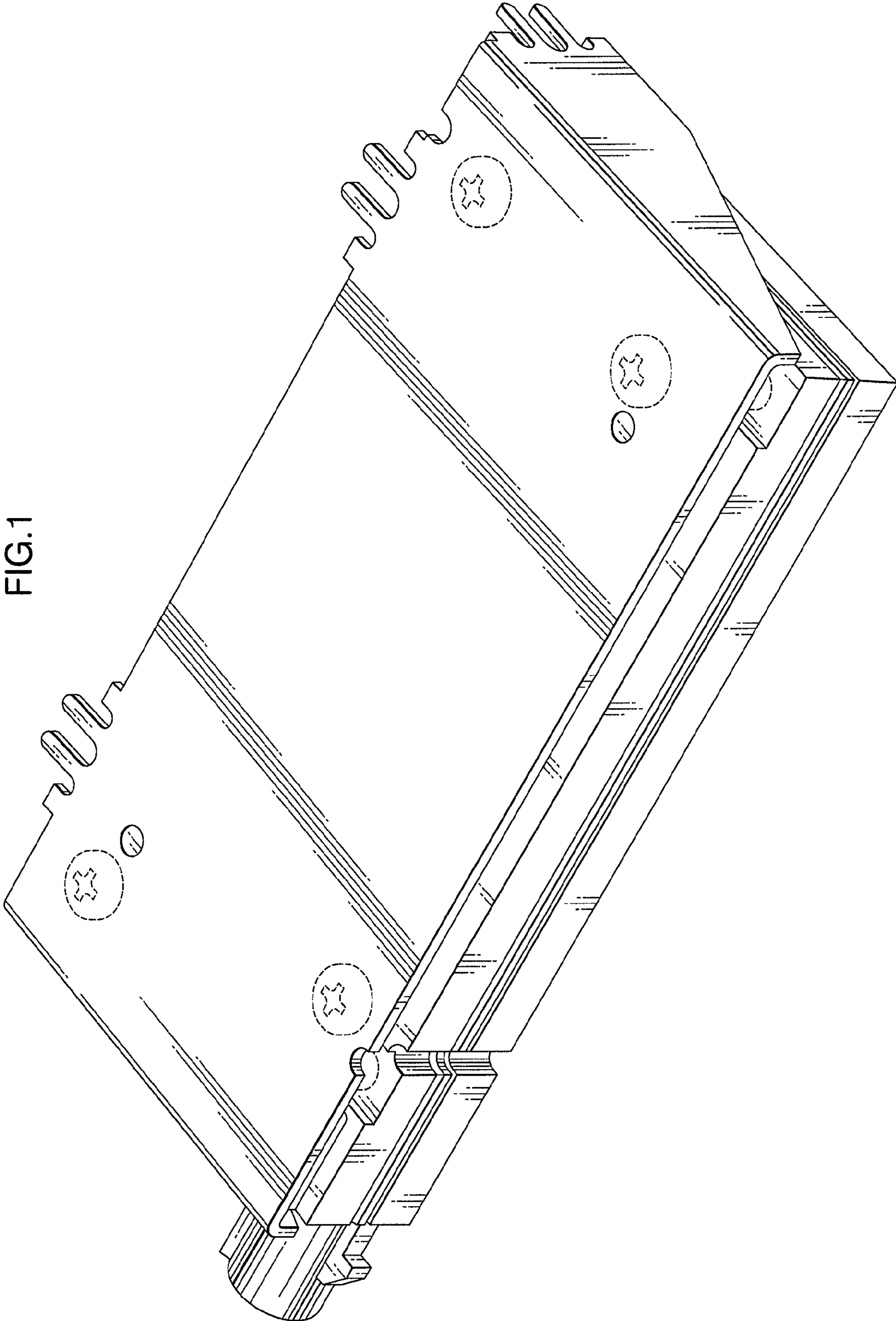

FIG. 1

FIG.2

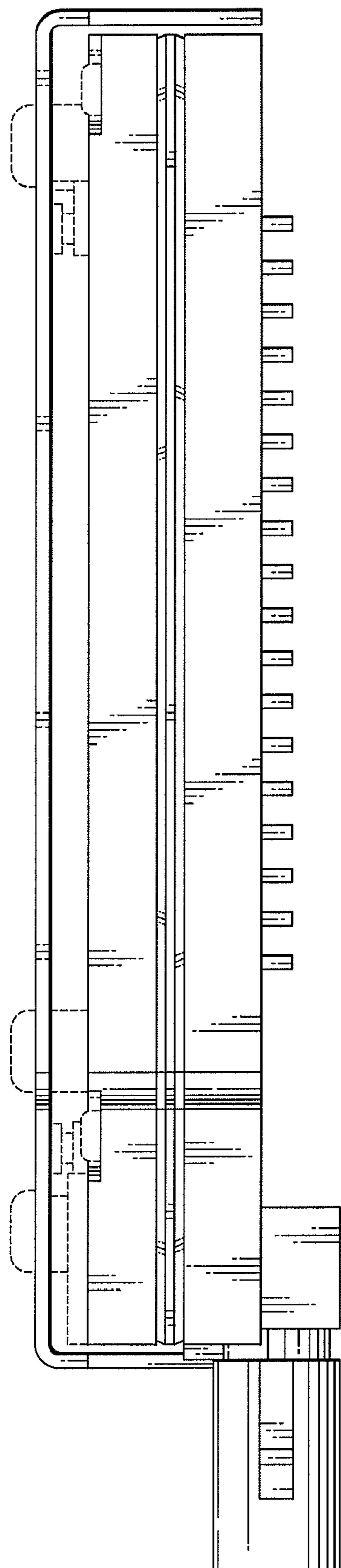

FIG.3

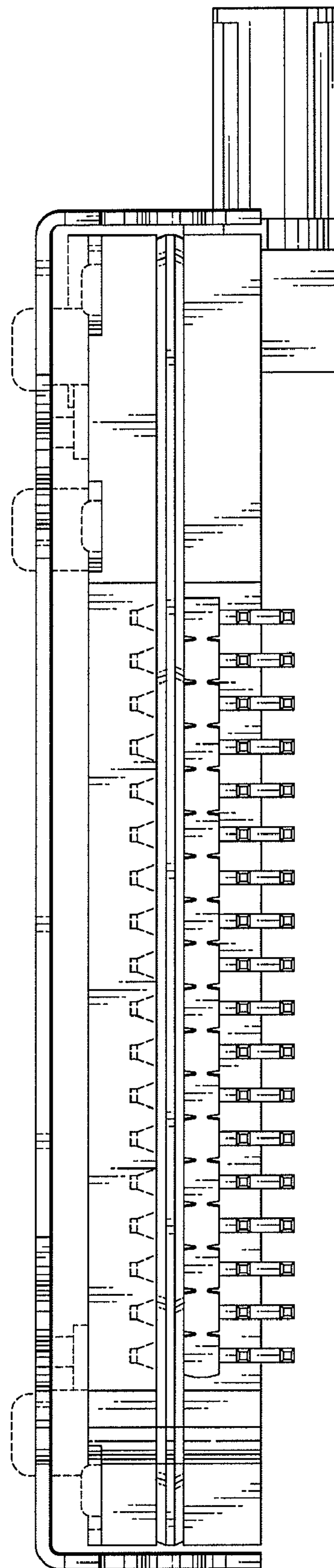

FIG.4

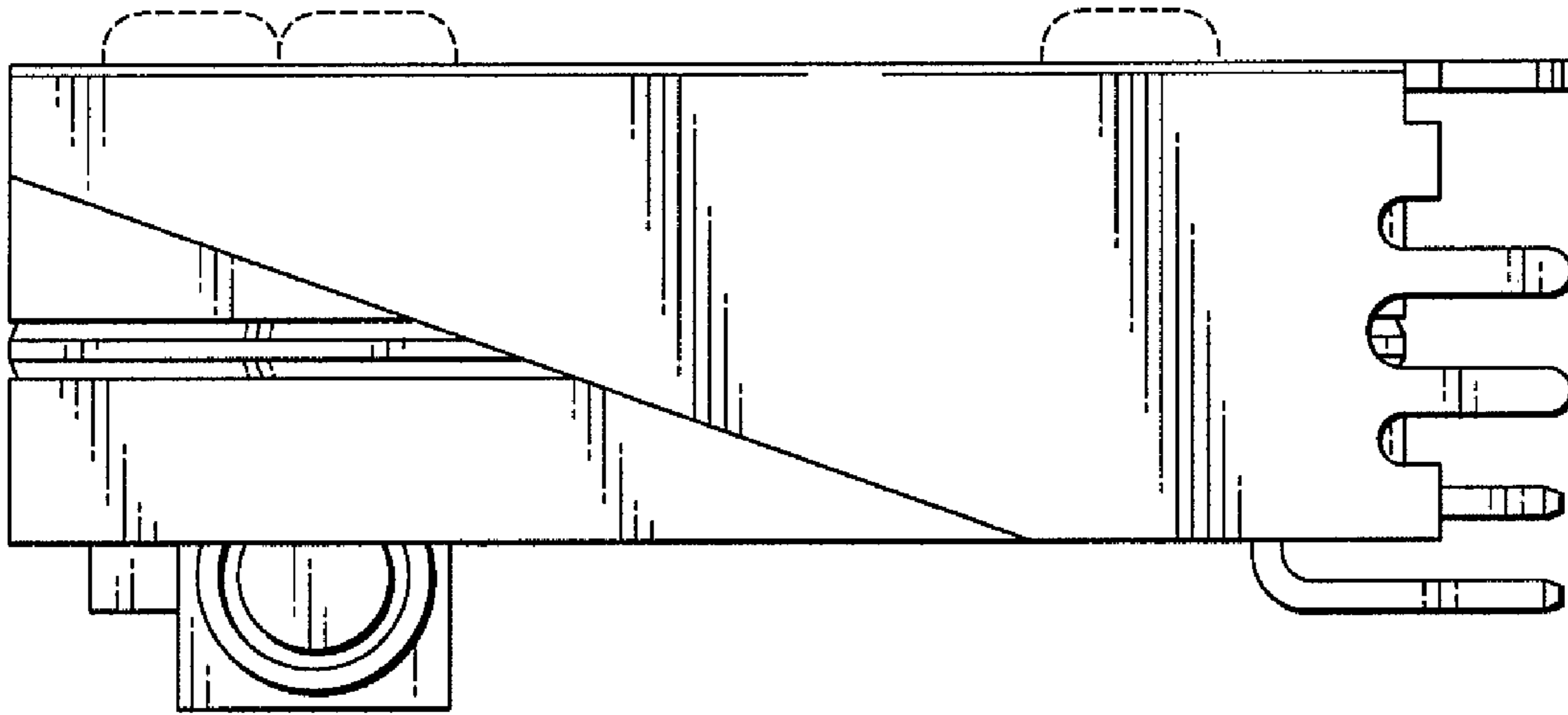

FIG.5

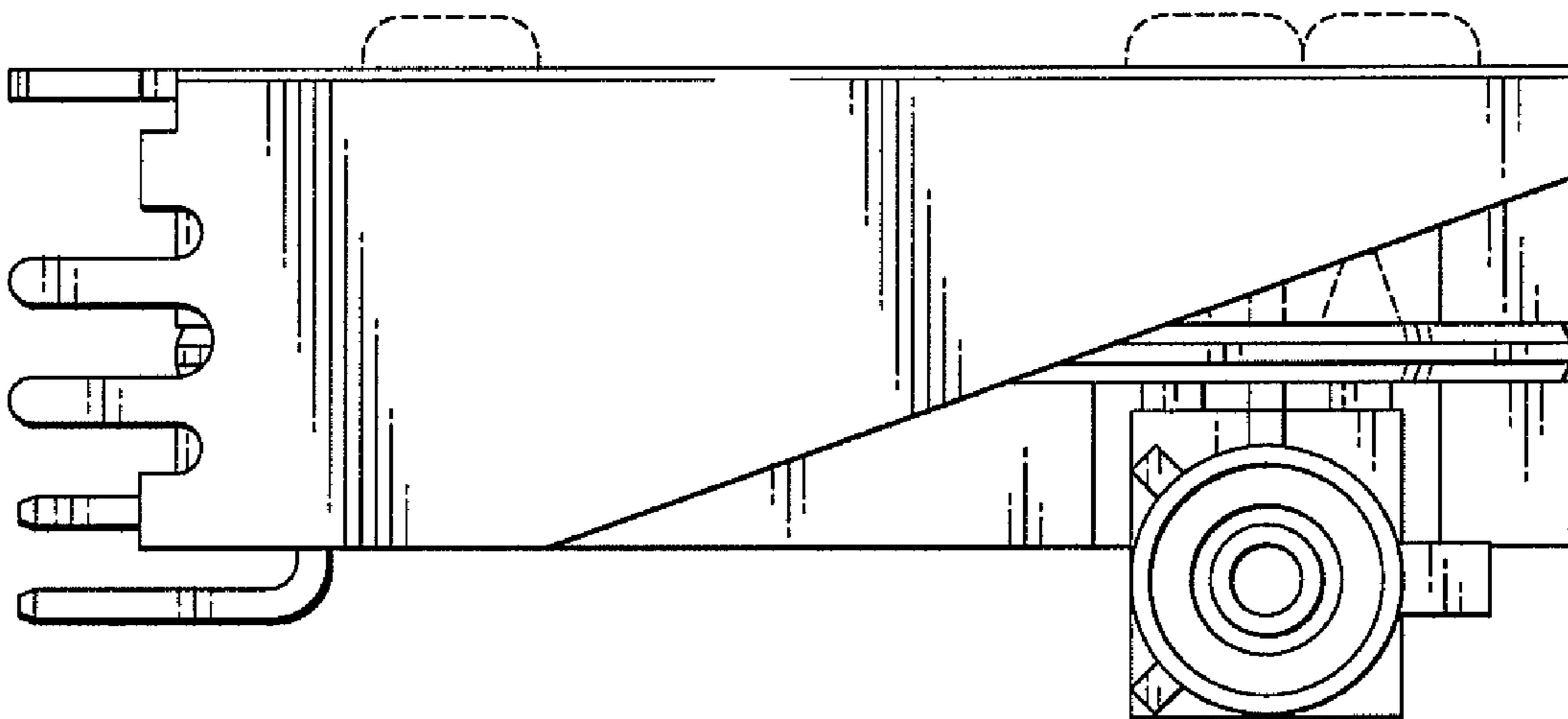

FIG.6

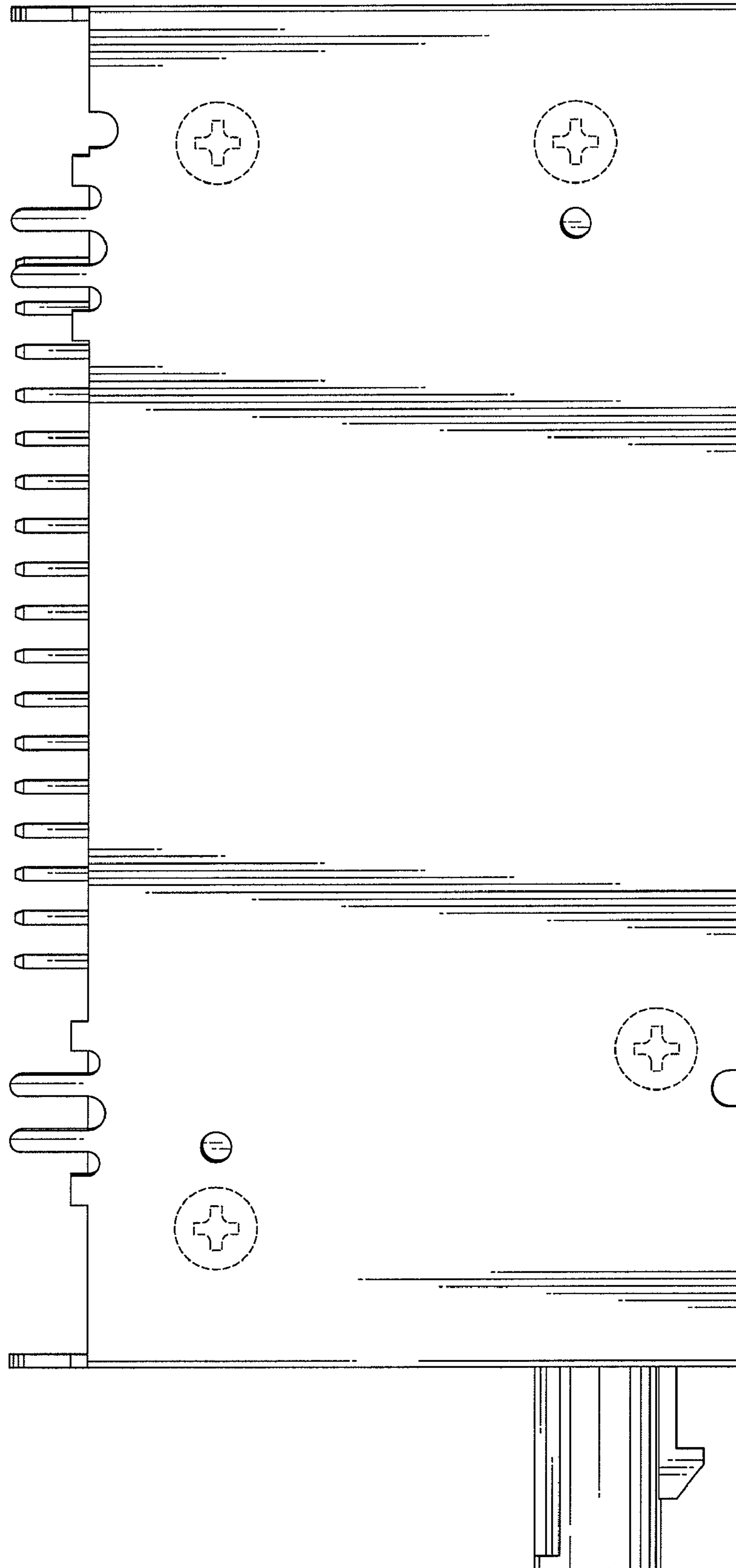
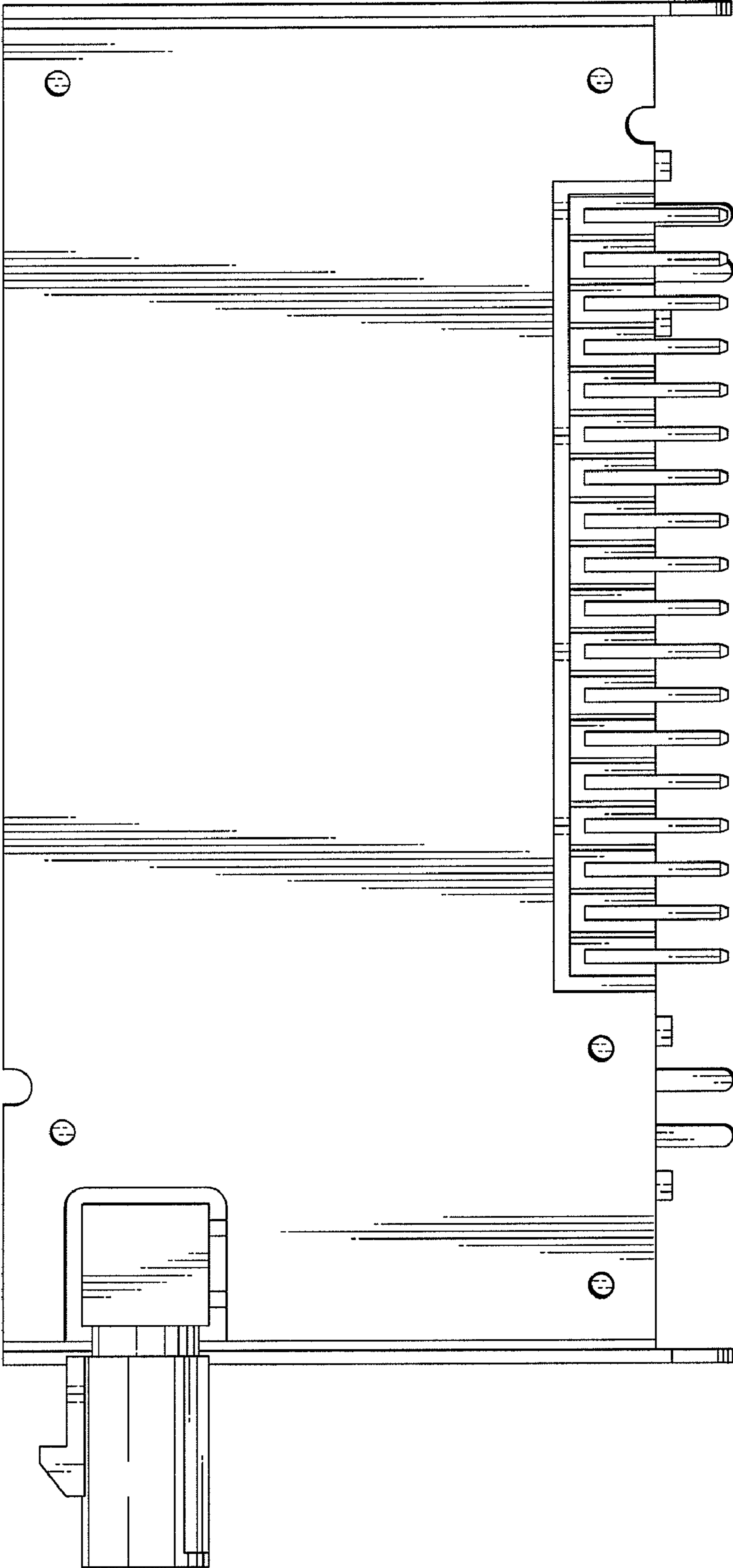

FIG.7



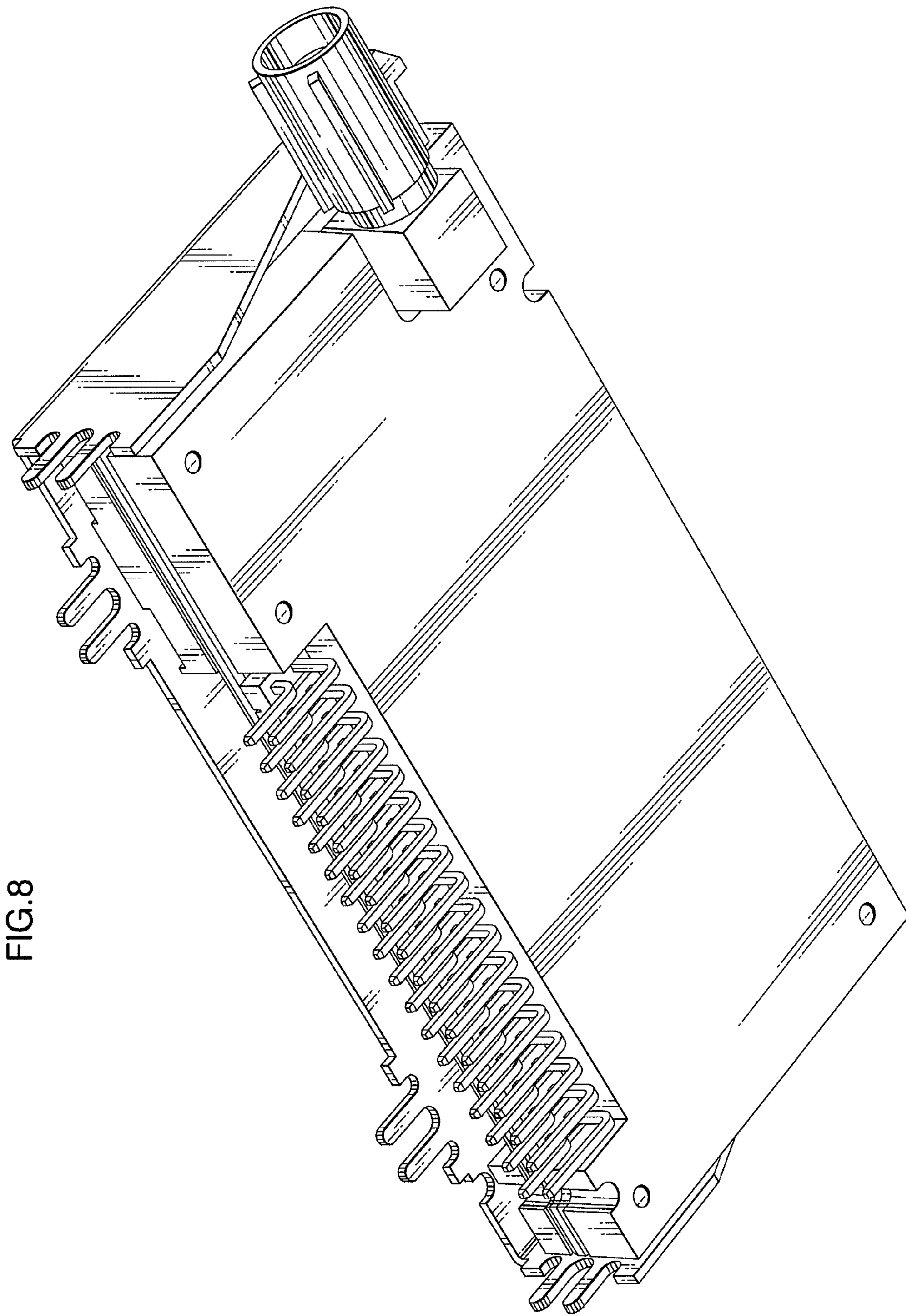

FIG.8