



US00D597919S

(12) **United States Design Patent**
Atwell

(10) **Patent No.:** **US D597,919 S**

(45) **Date of Patent:** **** Aug. 11, 2009**

(54) **AUTOMOBILE WHEEL**

D590,313 S * 4/2009 Baum D12/209

(75) Inventor: **Joseph T. Atwell**, Waterford, MI (US)

* cited by examiner

(73) Assignee: **Alcoa Inc.**, Pittsburgh, PA (US)

Primary Examiner—Cathron C Brooks

Assistant Examiner—Austin Murphy

(**) Term: **14 Years**

(74) *Attorney, Agent, or Firm*—Greenberg Traurig, LLP

(21) Appl. No.: **29/282,612**

(57) **CLAIM**

(22) Filed: **Jul. 25, 2007**

The ornamental design for an automobile wheel, as shown and described.

(51) **LOC (9) Cl.** **12-16**

(52) **U.S. Cl.** **D12/211**

(58) **Field of Classification Search** D12/204–213;
301/37.101, 64.101, 65, 64.201

See application file for complete search history.

DESCRIPTION

(56) **References Cited**

FIG. 1 is a perspective view of an automobile wheel in accordance with my new design (wherein the automobile wheel is shown with a tire mounted thereon);

FIG. 2 is a perspective view of the automobile wheel of FIG. 1 (wherein the automobile wheel is shown without a tire mounted thereon); and,

FIG. 3 is a front view of the automobile wheel of FIG. 1 (wherein the automobile wheel is shown without a tire mounted thereon).

U.S. PATENT DOCUMENTS

D402,251 S	*	12/1998	Timm	D12/211
D405,749 S	*	2/1999	Kulla	D12/211
D432,974 S	*	10/2000	Jablonski	D12/211
D450,647 S	*	11/2001	Pfeiffer	D12/211
D461,441 S	*	8/2002	Hartanto	D12/211
D488,420 S	*	4/2004	Murkett et al.	D12/209
D494,525 S	*	8/2004	Borkert	D12/211
D521,438 S	*	5/2006	Nordmann	D12/211
D524,217 S	*	7/2006	Aoki	D12/211
D534,473 S	*	1/2007	Bernoni	D12/211
D537,767 S	*	3/2007	Pfeiffer	D12/211
D539,204 S	*	3/2007	Pollmann	D12/209

The broken lines outlining the tire in FIG. 1 are for illustrative purposes only and form no part of the claimed design.

The broken lines outlining the rim portion of the automobile wheel in FIG. 2 are for illustrative purposes only and form no part of the claimed design.

1 Claim, 3 Drawing Sheets

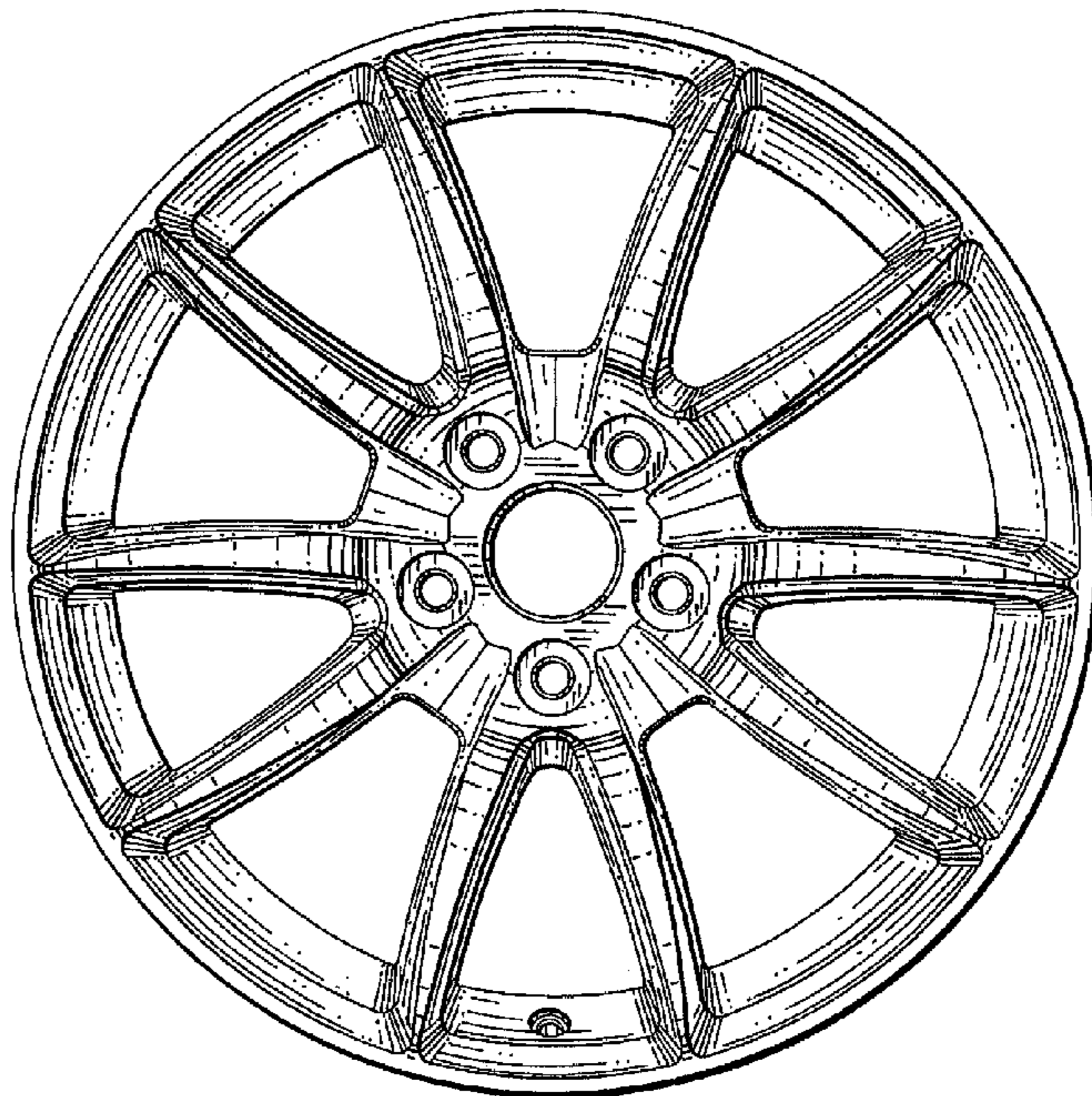
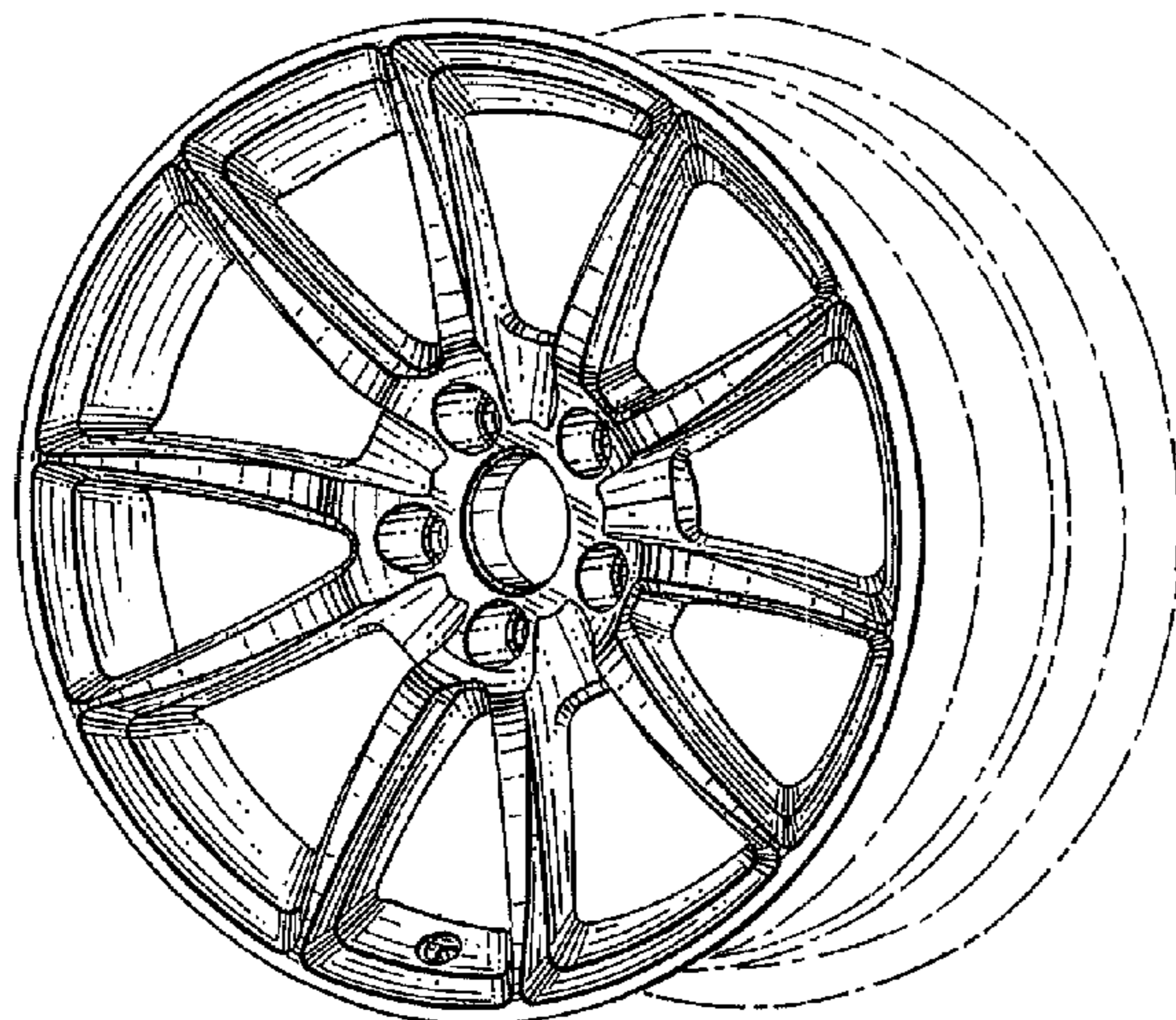

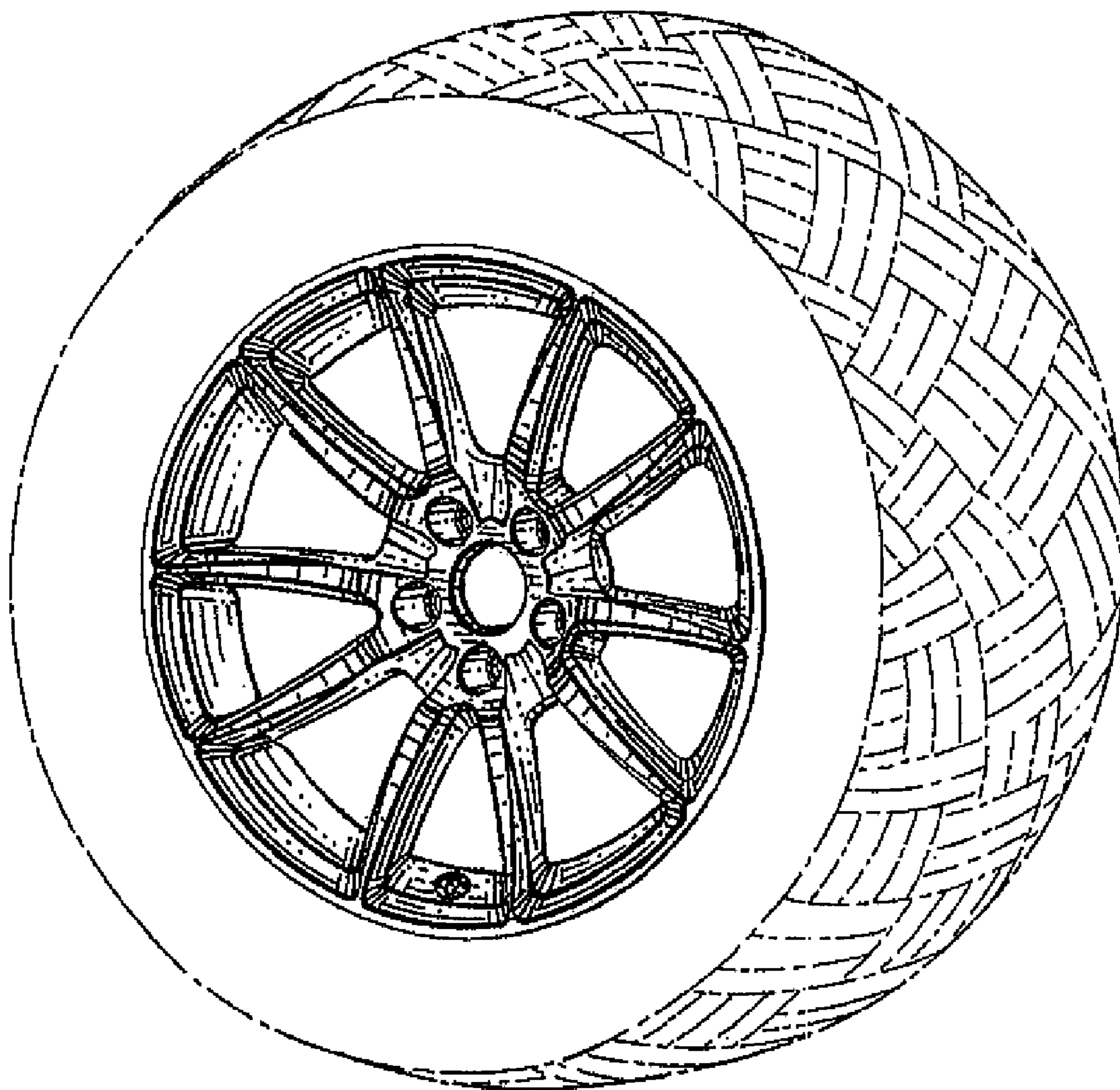

FIG. 1

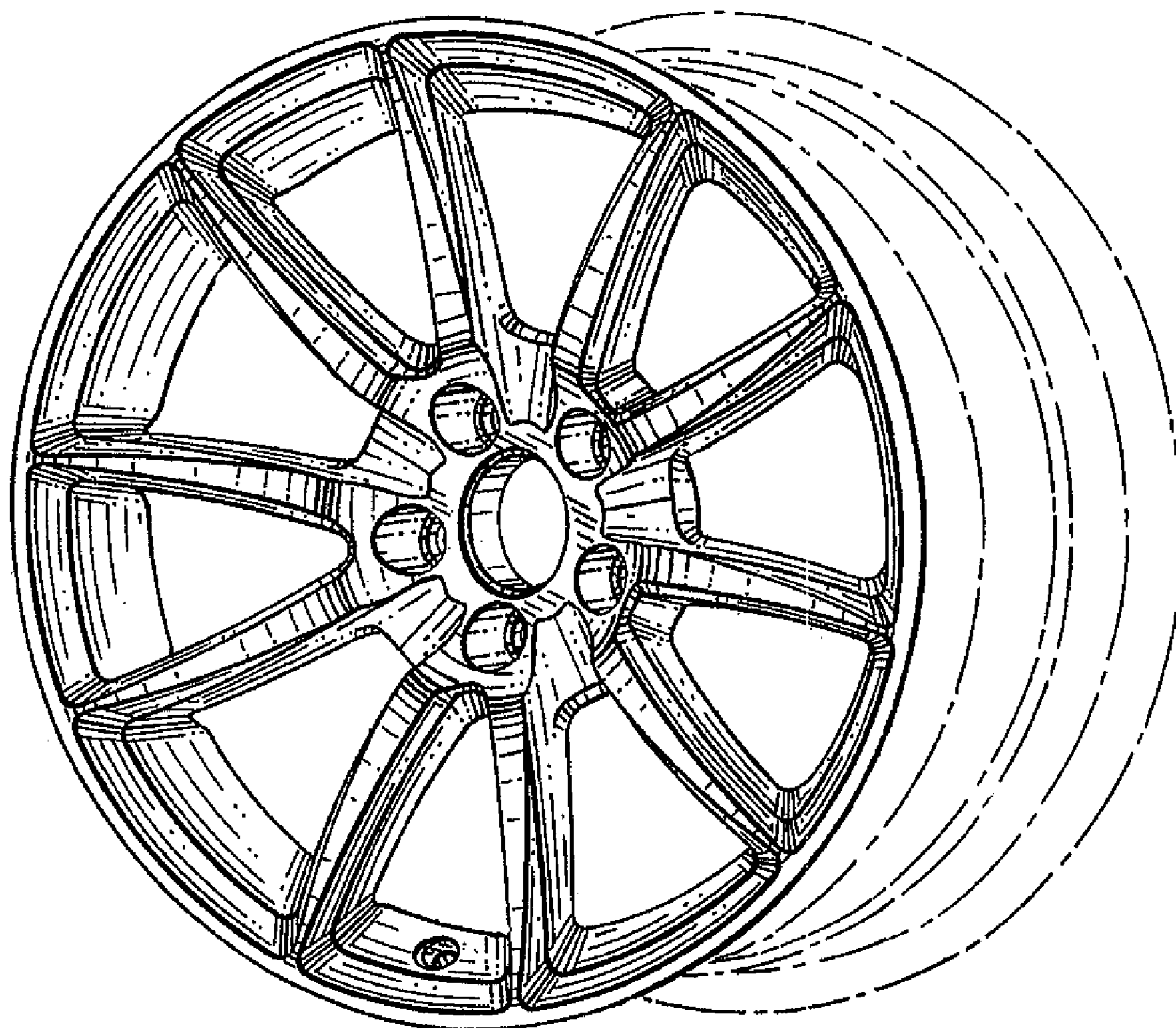

FIG. 2

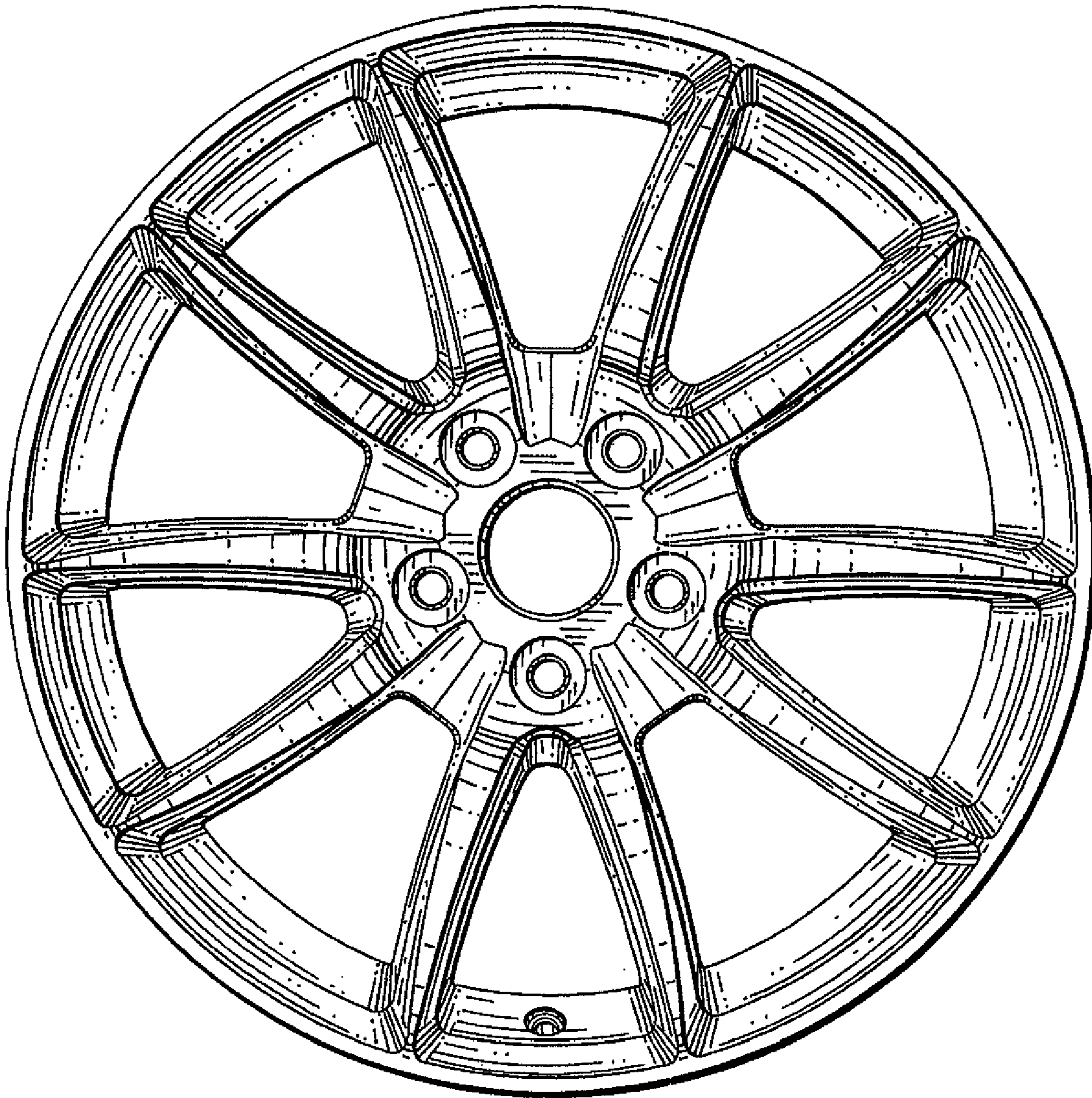

FIG. 3