

US00D597890S

(12) **United States Design Patent**
Lai et al.

(10) **Patent No.:** **US D597,890 S**

(45) **Date of Patent:** **** Aug. 11, 2009**

(54) **ALL TERRAIN VEHICLE**

(75) Inventors: **Guogui Lai**, Hangzhou (CN); **Youheng Qian**, Hangzhou (CN); **Zhangping Yuan**, Hangzhou (CN); **Changwei Wang**, Hangzhou (CN); **Jinpin Zheng**, Hangzhou (CN); **Minqiang Xiong**, Hangzhou (CN); **Guohui Wu**, Hangzhou (CN)

(73) Assignee: **Chunfeng Holding Group Hangzhou Motorcycles Manufacturing Co., Ltd.**, Zhangzhou, Zhejiang Province (CN)

(**) Term: **14 Years**

(21) Appl. No.: **29/303,076**

(22) Filed: **Jan. 31, 2008**

(30) **Foreign Application Priority Data**

Oct. 19, 2007 (CN) 2007 3 0330215

(51) **LOC (9) Cl.** **12-11**

(52) **U.S. Cl.** **D12/107**

(58) **Field of Classification Search** D12/3,
D12/86, 87, 107, 110; 180/225, 229, 233,
180/311, 312, 315

See application file for complete search history.

(56) **References Cited**

U.S. PATENT DOCUMENTS

D436,557 S 1/2001 Selby et al.
6,523,879 B2 2/2003 Mizuta
D504,638 S 5/2005 Tanaka et al.
D511,317 S 11/2005 Tanaka et al.

D516,467 S * 3/2006 Wu D12/107
D520,912 S * 5/2006 Knight et al. D12/107
D520,914 S * 5/2006 Luh D12/107
D522,924 S * 6/2006 Yokoyama et al. D12/107
7,093,580 B2 8/2006 McLeod
D529,414 S * 10/2006 Wu et al. D12/107
D542,186 S * 5/2007 Lai et al. D12/107
D578,433 S 10/2008 Kawaguchi et al.
D578,934 S 10/2008 Tanaka et al.
D579,821 S 11/2008 Bobbitt, III et al.
2005/0212244 A1 9/2005 Bobbitt, III et al.
2008/0023240 A1 1/2008 Sundahl et al.
2008/0230294 A1 9/2008 Smith et al.

* cited by examiner

Primary Examiner—Robin V Webster

Assistant Examiner—Linda Brooks

(74) *Attorney, Agent, or Firm*—Alston & Bird LLP

(57) **CLAIM**

The ornamental design for an all terrain vehicle, as shown and described.

DESCRIPTION

FIG. 1 is a perspective view of an all terrain vehicle according to our new design;

FIG. 2 is a front elevation view thereof;

FIG. 3 is a rear elevation view thereof;

FIG. 4 is a left side elevation view thereof;

FIG. 5 is a right side elevataion view thereof; and,

FIG. 6 is a top plan view thereof.

The broken lines shown herein are illustrative of environmental structure and form no part of the claimed design.

1 Claim, 6 Drawing Sheets

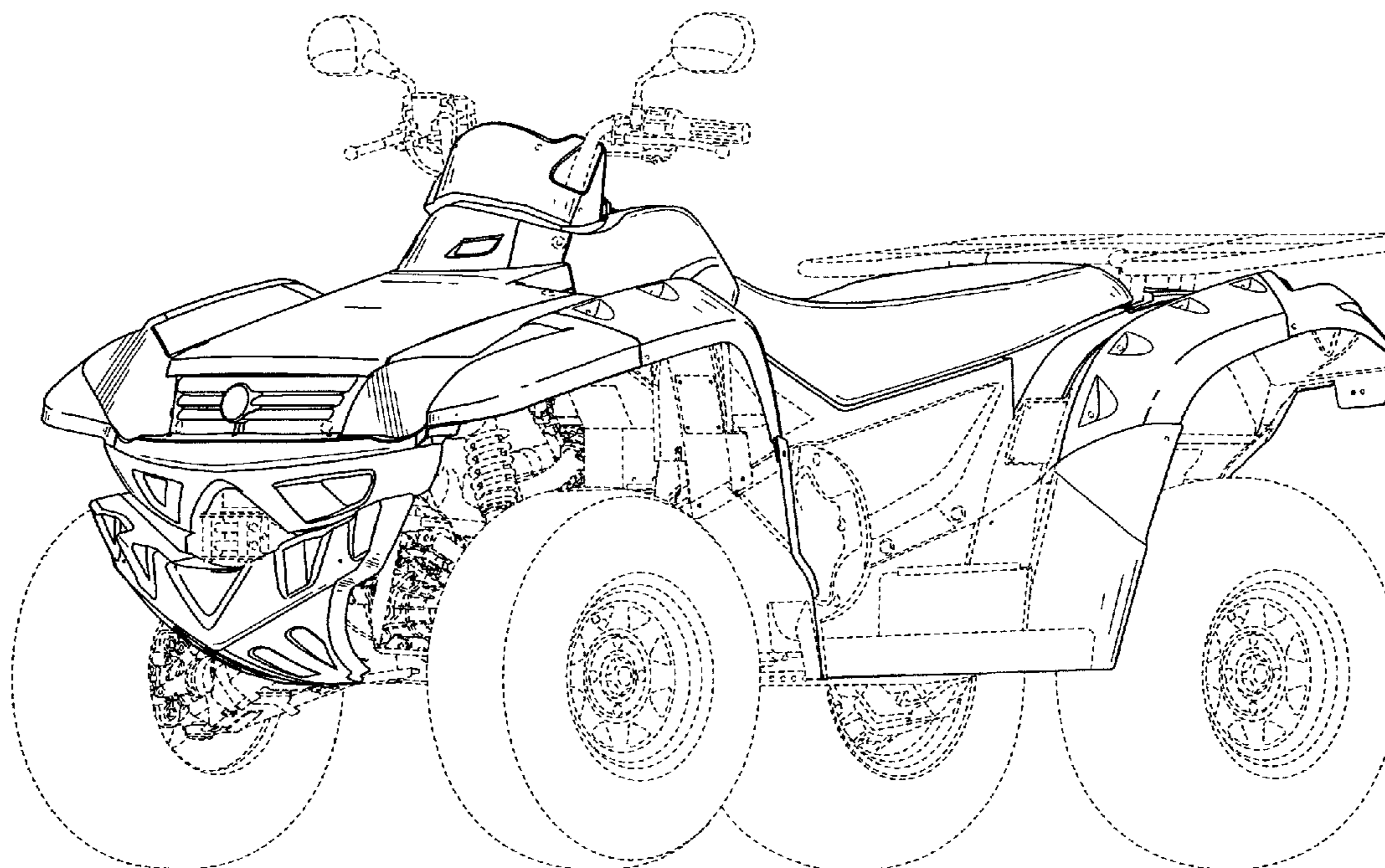

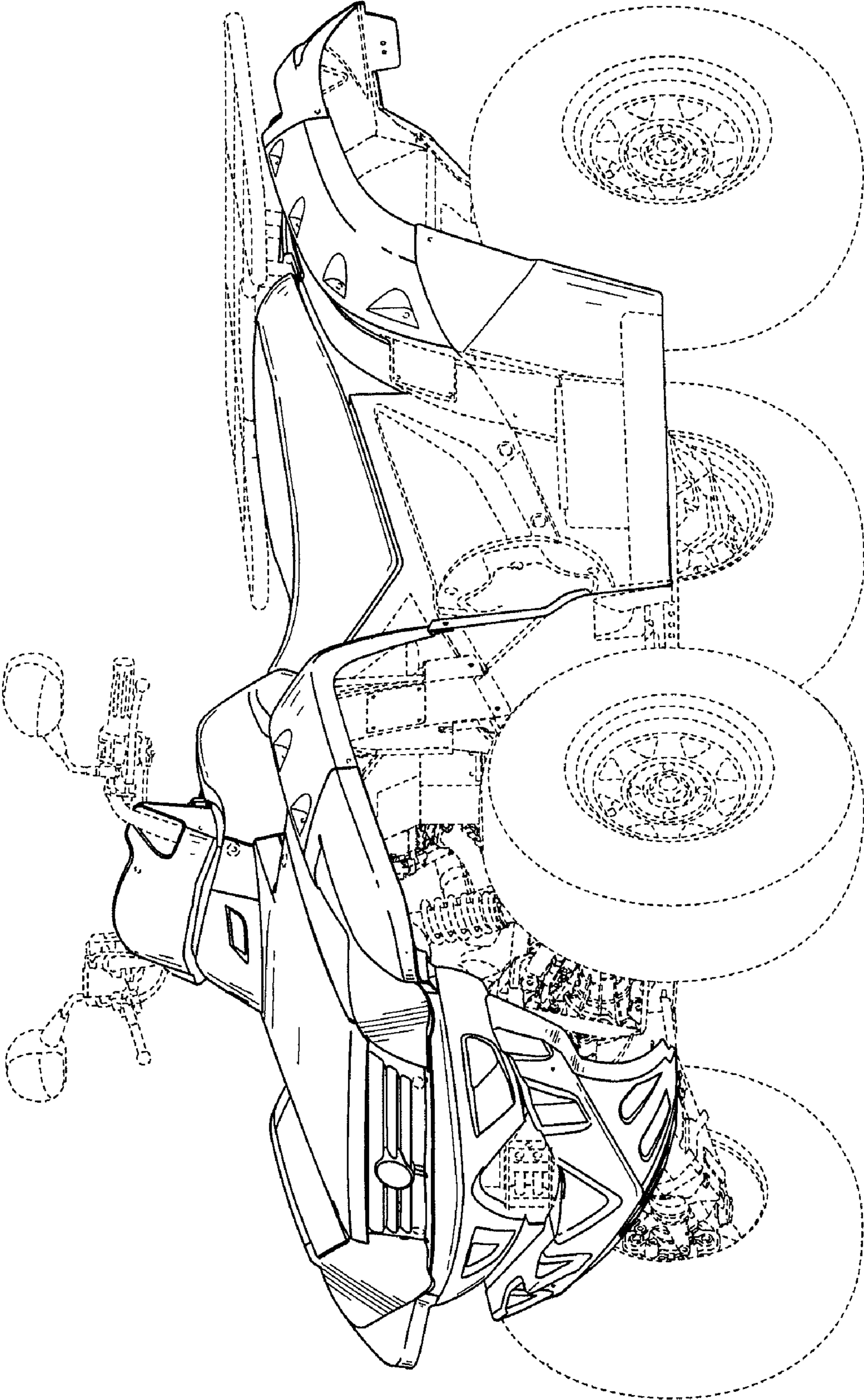

FIG. 1

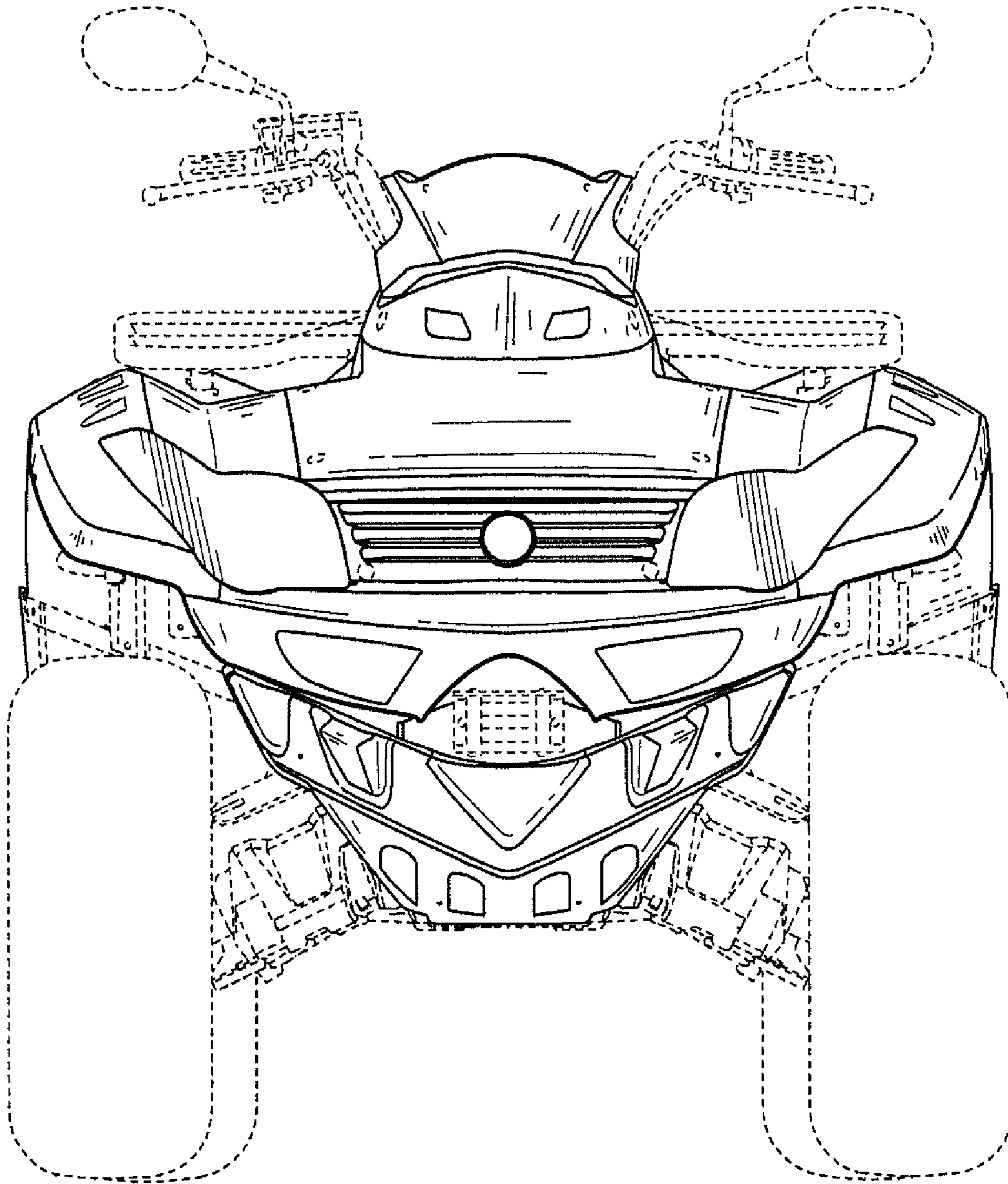

FIG. 2

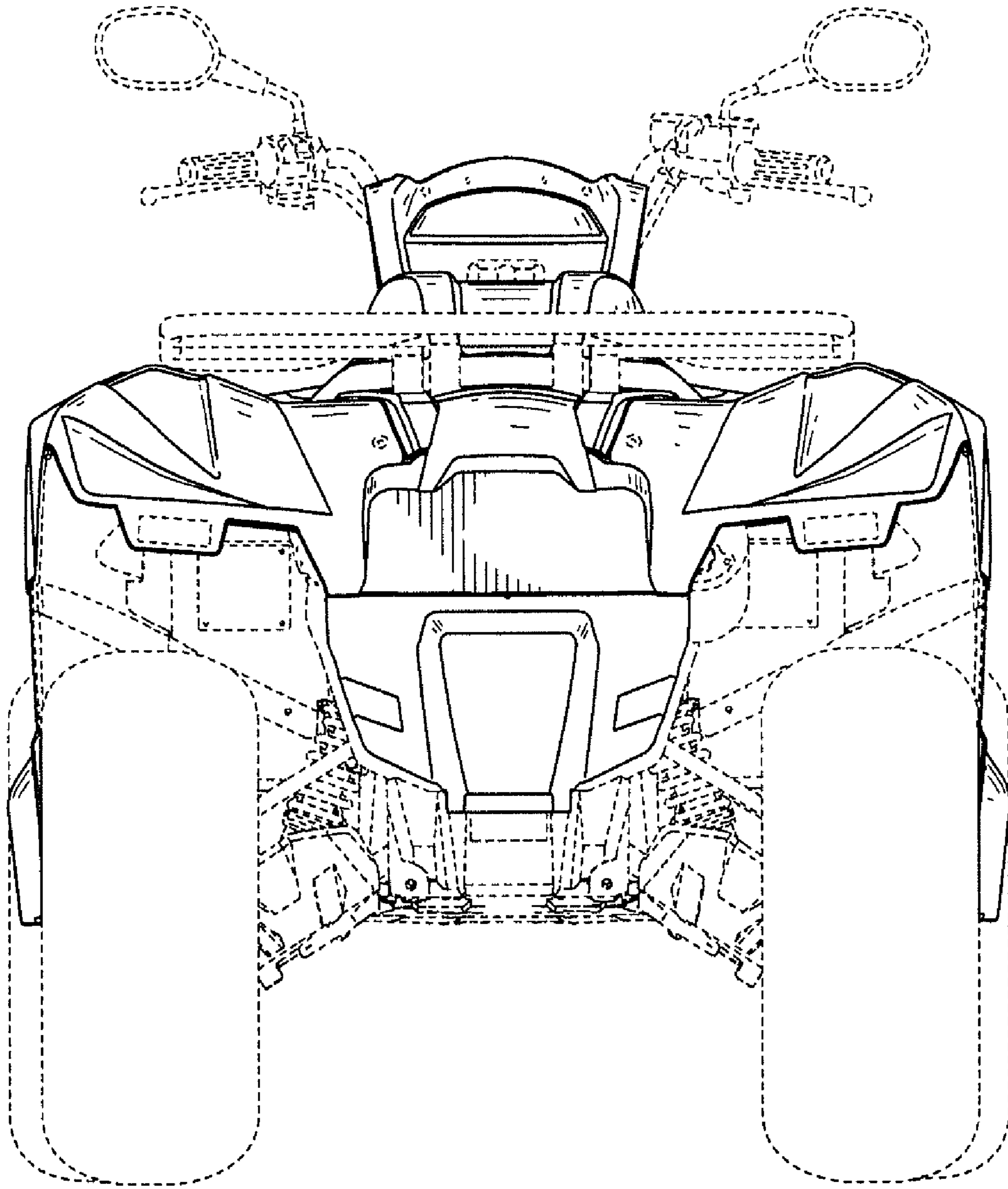

FIG. 3

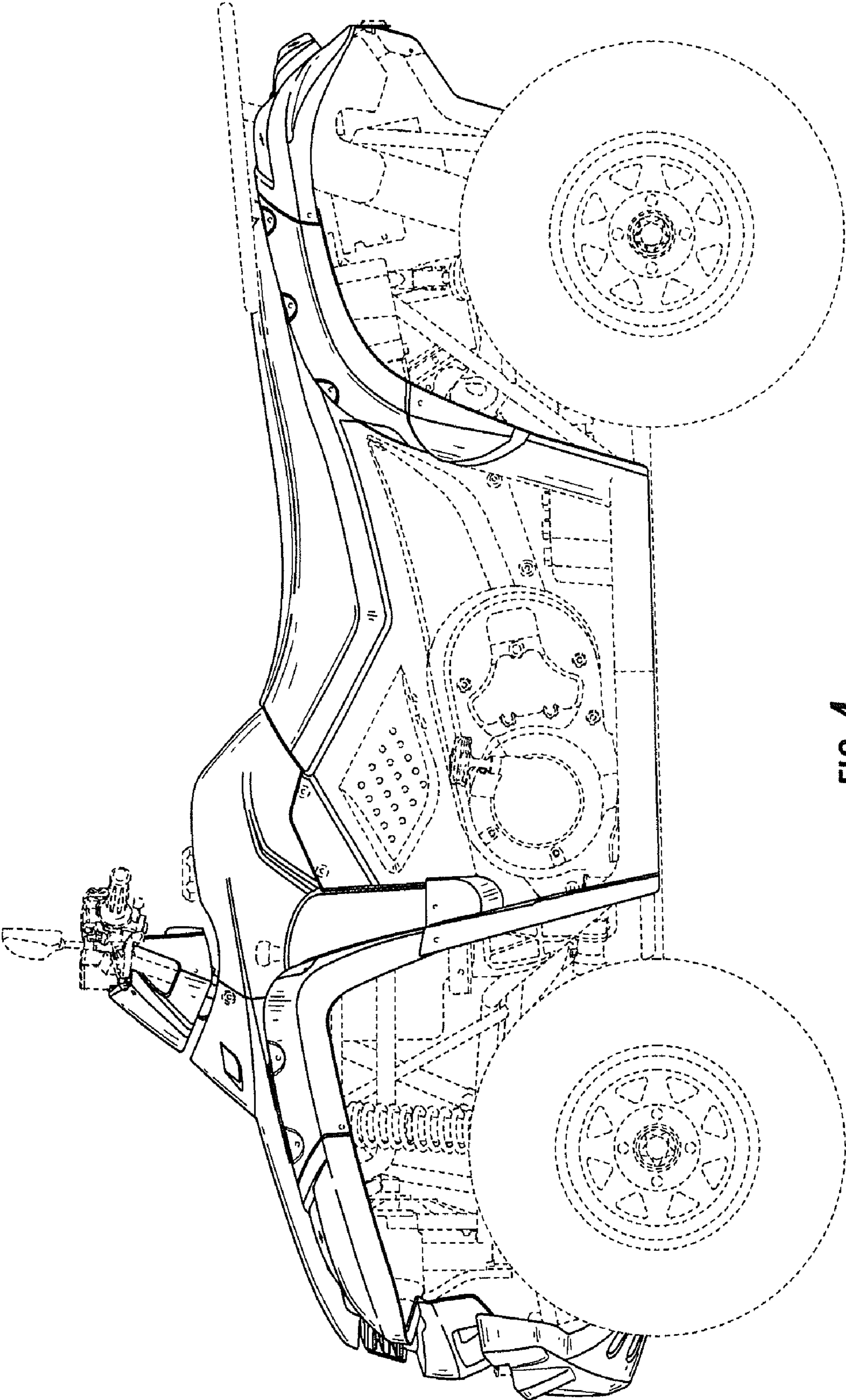

FIG. 4

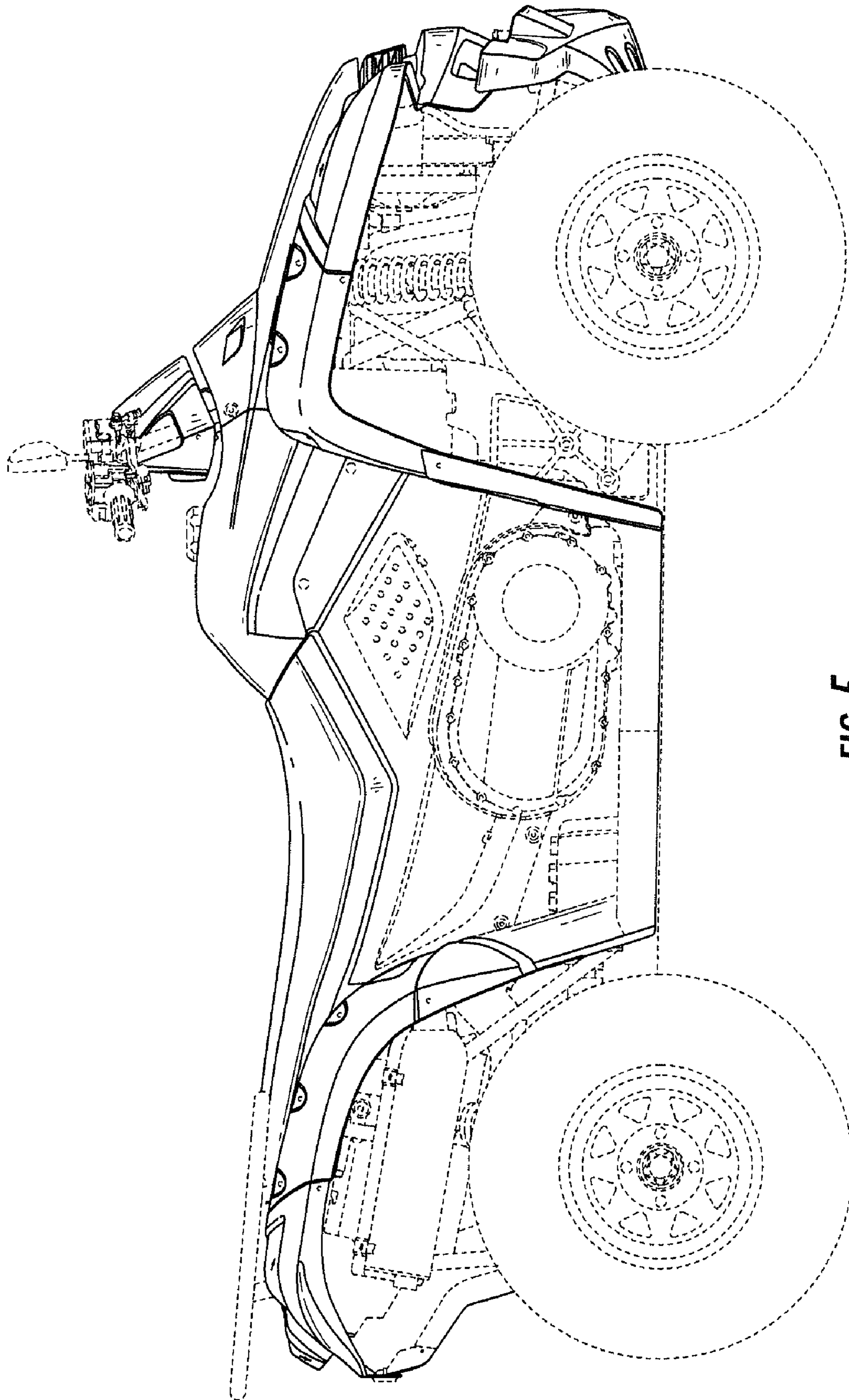

FIG. 5

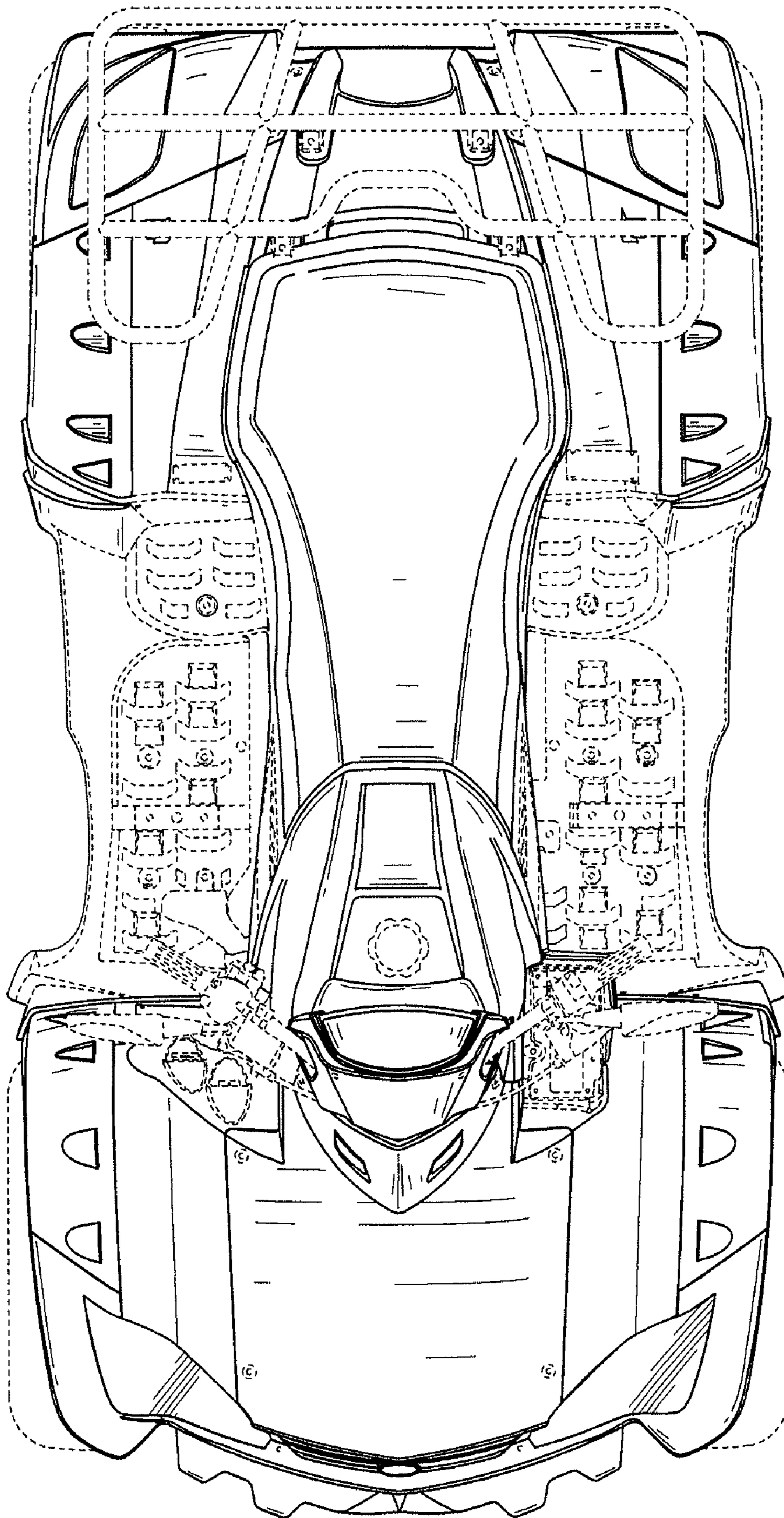

FIG. 6