



US00D597879S

(12) **United States Design Patent**  
**Aikawa**

(10) **Patent No.:** **US D597,879 S**  
(45) **Date of Patent:** **\*\* Aug. 11, 2009**

(54) **REMOTE CONTROLLER FOR VEHICLES**

(75) Inventor: **Masami Aikawa**, Chiyoda-Ku (JP)

(73) Assignee: **Mitsubishi Electric Corporation**,  
Tokyo (JP)

(\*\*) Term: **14 Years**

(21) Appl. No.: **29/325,933**

(22) Filed: **Oct. 8, 2008**

(30) **Foreign Application Priority Data**

Apr. 9, 2008 (JP) ..... 2008-009073

(51) **LOC (9) Cl.** ..... **10-05**

(52) **U.S. Cl.** ..... **D10/104**

(58) **Field of Classification Search** ..... D10/104,  
D10/106; D13/168, 207; D14/138, 218,  
D14/154, 168, 188; 362/157, 116, 200, 186,  
362/87; D26/37, 38, 63; 455/351, 350; 340/426.31,  
340/546, 628, 815.4, 815.73

See application file for complete search history.

(56) **References Cited**

**U.S. PATENT DOCUMENTS**

D398,304 S \* 9/1998 Murray et al. .... D14/137  
(Continued)

**OTHER PUBLICATIONS**

“Remote Control Key for Volvo S80,” Catalogue of Volvo Corpora-  
tion, The Instruction Manual of Volvo S80, 2007, p. 42-57.

*Primary Examiner*—Caron Veynar

*Assistant Examiner*—George D Kirschbaum

(74) *Attorney, Agent, or Firm*—Sughrue Mion, PLLC

(57) **CLAIM**

The ornamental design for a remote controller for vehicles, as  
shown and described.

**DESCRIPTION**

FIG. 1 is a front, top and right side perspective view of a  
remote controller for vehicles, showing my new design;

FIG. 2 is a front elevational view thereof;

FIG. 3 is a rear elevational view thereof;

FIG. 4 is a top plan view thereof;

FIG. 5 is a bottom plan view thereof;

FIG. 6 is a left side elevational view thereof;

FIG. 7 is a right side elevational view thereof;

FIG. 8 is an enlarged cross-sectional view thereof; taken  
along line 8—8 of FIG. 2;

FIG. 9 is an enlarged cross-sectional view thereof; taken  
along line 9—9 of FIG. 2;

FIG. 10 is an enlarged cross-sectional view thereof; taken  
along line 10—10 of FIG. 2;

FIG. 11 is an enlarged cross-sectional view thereof; taken  
along line 11—11 of FIG. 4;

FIG. 12 is a front elevational view of the top section of the  
design thereof;

FIG. 13 is a rear elevational view of the top section of the  
design thereof;

FIG. 14 is a bottom plan view of the top section of the design  
thereof;

FIG. 15 is a left side elevational view of the top section of the  
design thereof;

FIG. 16 is a right side elevational view of the top section of the  
design thereof;

FIG. 17 is a front elevational view of the bottom section of the  
design thereof;

FIG. 18 is a rear elevational view of the top section of the  
design thereof;

FIG. 19 is a top plan view of the top section of the design  
thereof;

FIG. 20 is a left side elevational view of the top section of the  
design thereof;

FIG. 21 is a right side elevational view of the top section of the  
design thereof; and,

FIG. 22 is a reference top plan view with the light-transmit-  
ting portion of the design shown in a lighted state.

The broken lines in all views are shown for illustrative pur-  
poses only and form no part of the claimed design.

**1 Claim, 6 Drawing Sheets**

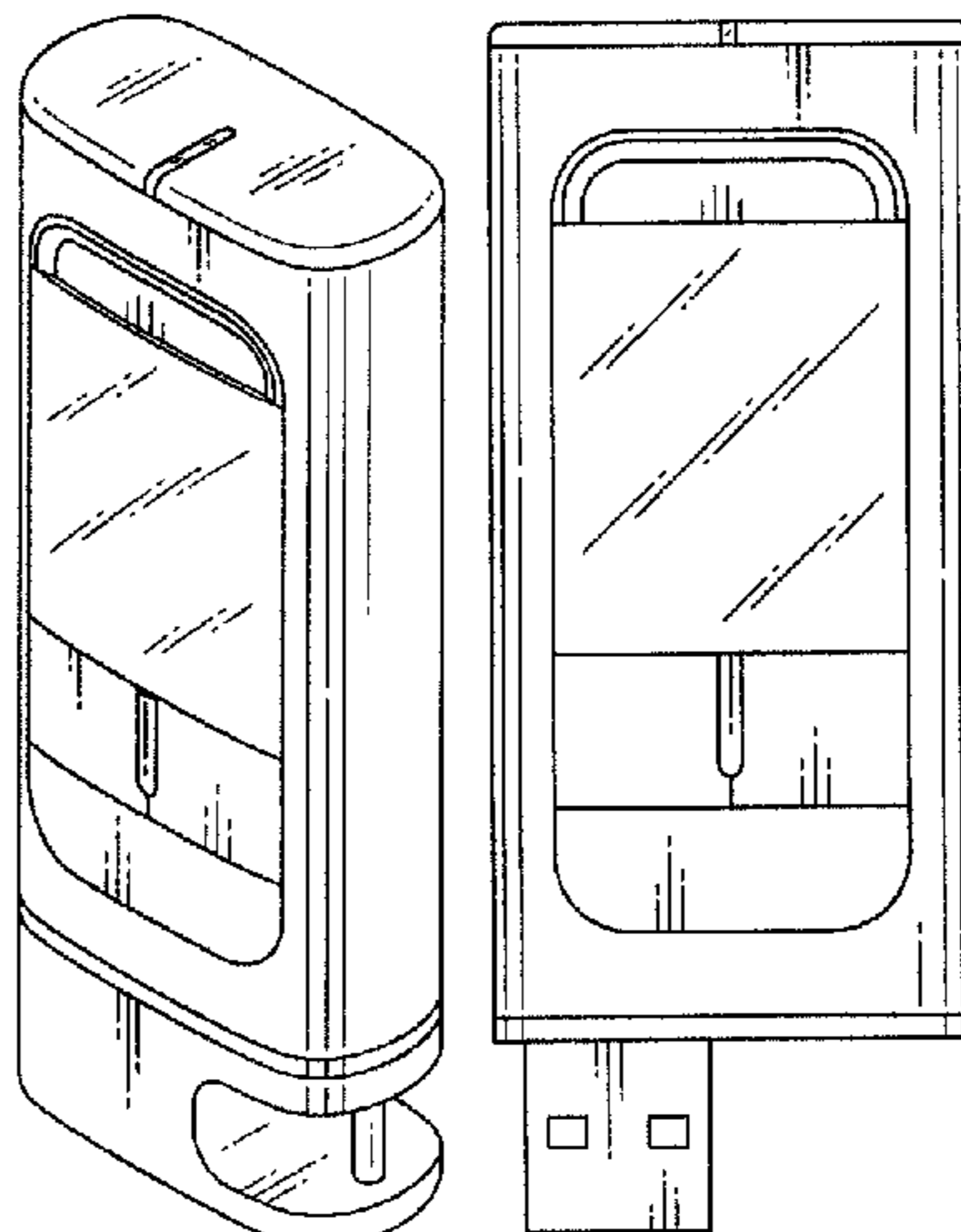

# US D597,879 S

Page 2

---

## U.S. PATENT DOCUMENTS

D406,779 S *	3/1999	Pinardi et al.	.....	D10/104	7,287,873 B2 *	10/2007	Galli	.....	362/158
D469,708 S *	2/2003	To et al.	.....	D10/104	D557,111 S *	12/2007	Ydremark et al.	.....	D8/347
D530,342 S *	10/2006	Lee et al.	.....	D14/496	D558,783 S *	1/2008	Andre et al.	.....	D14/496
D546,837 S *	7/2007	Yeo	.....	D14/496	D569,289 S *	5/2008	Bender	.....	D10/104
D550,711 S *	9/2007	Lee	.....	D14/496	2003/0179573 A1 *	9/2003	Chun	.....	362/200
					2006/0034070 A1 *	2/2006	Kovacik et al.	.....	362/157

\* cited by examiner

FIG.1

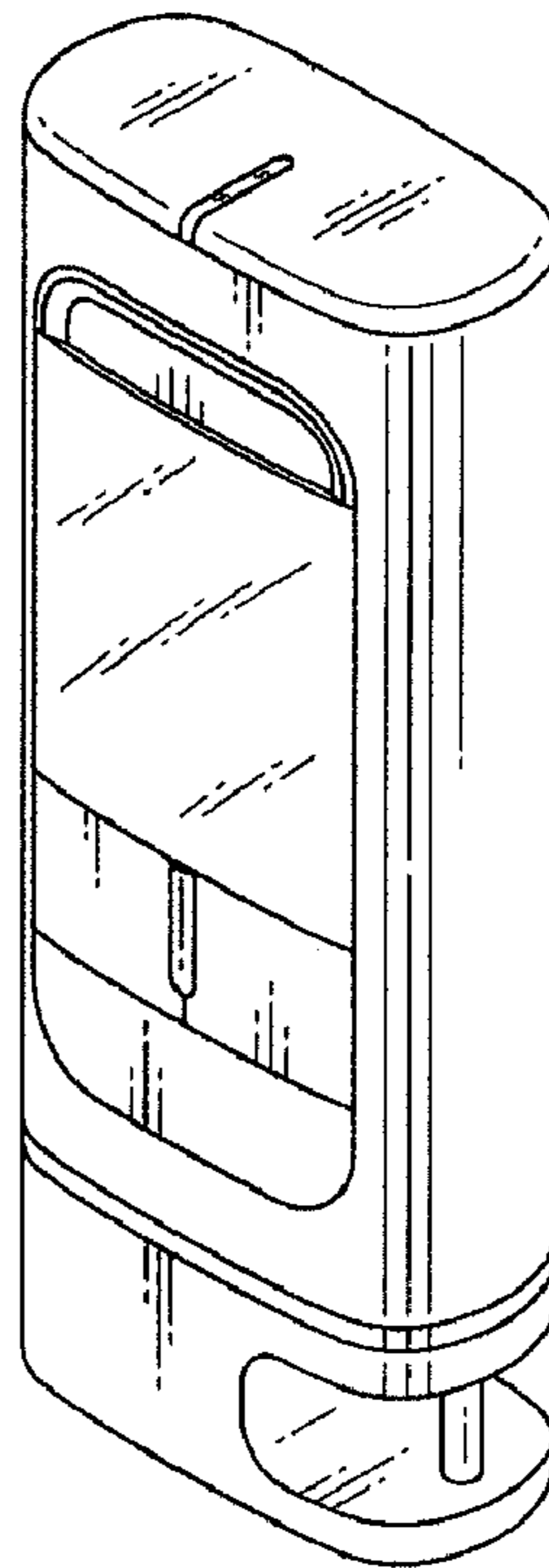

FIG.2

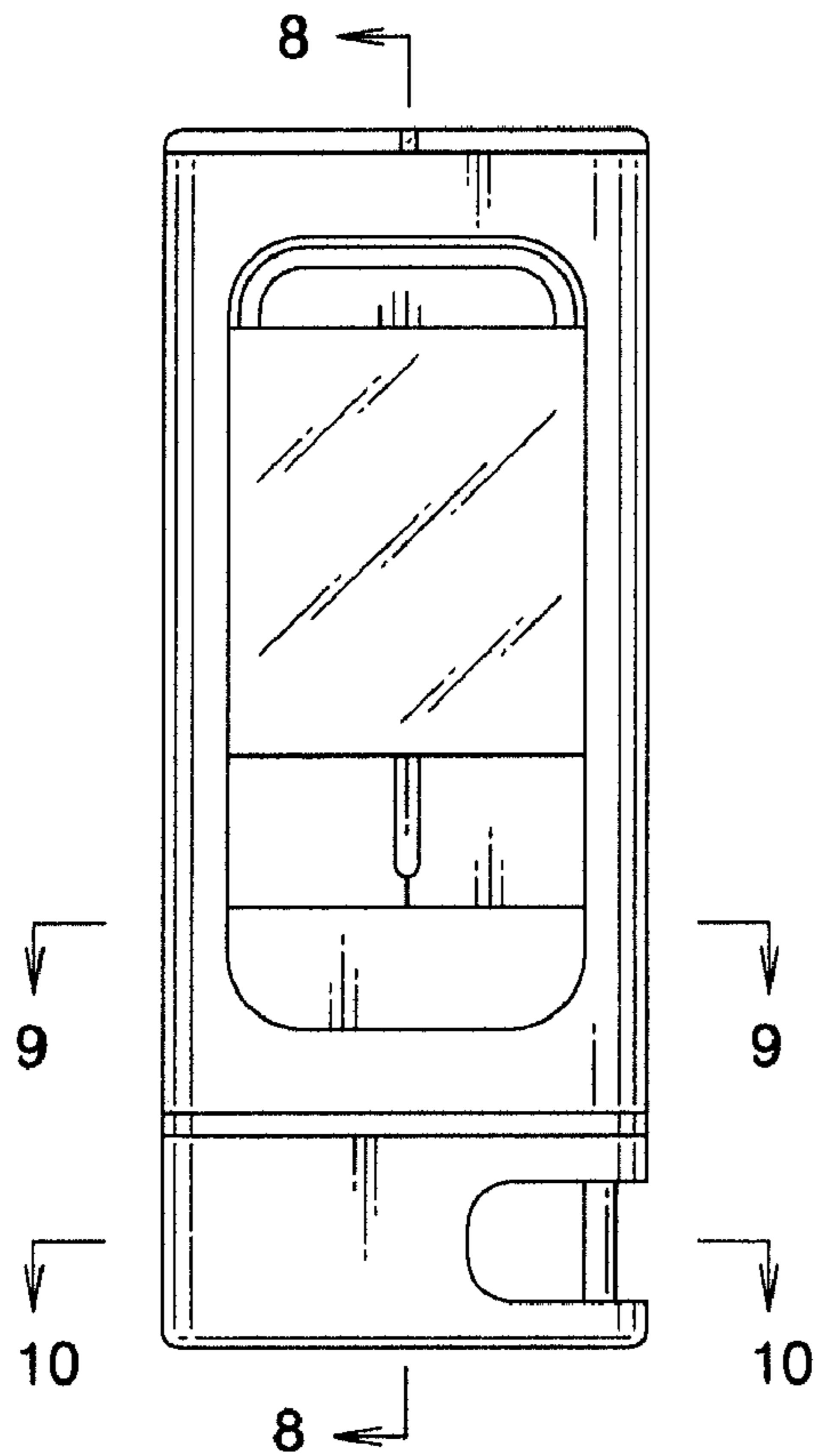

FIG.3

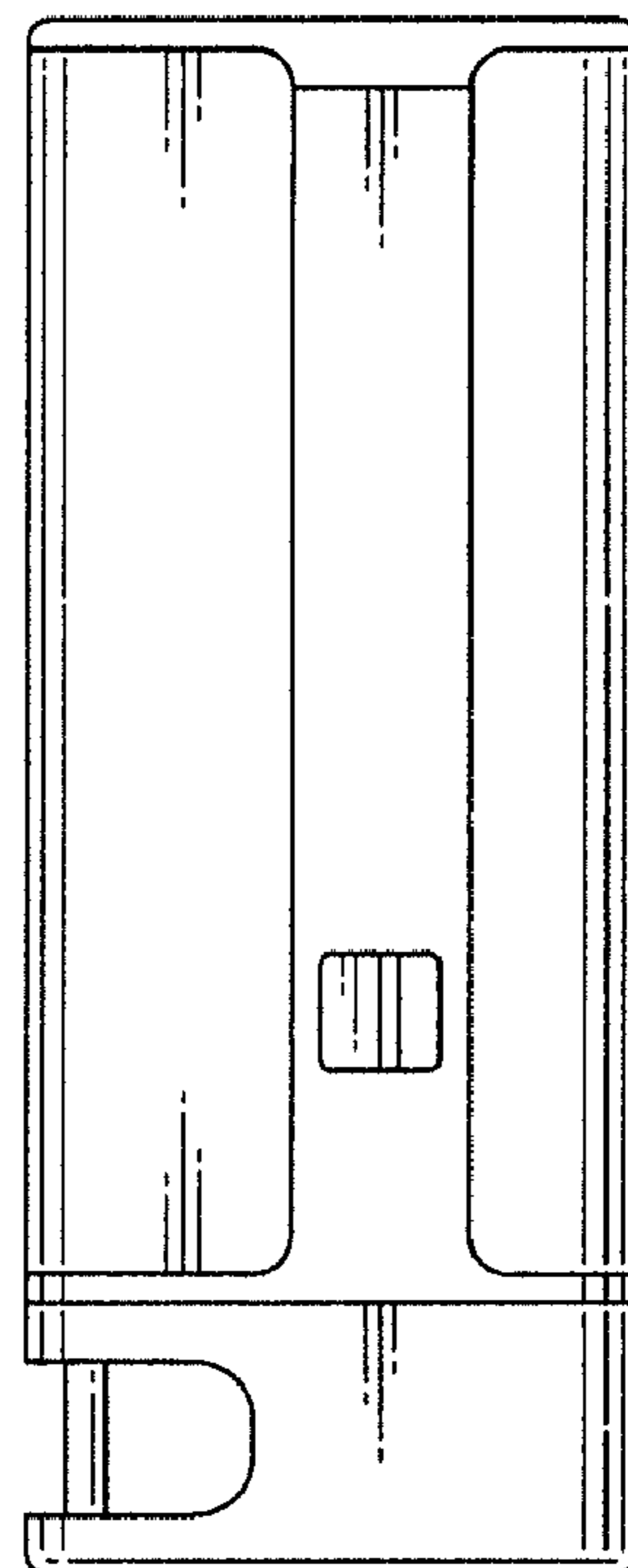

FIG.4

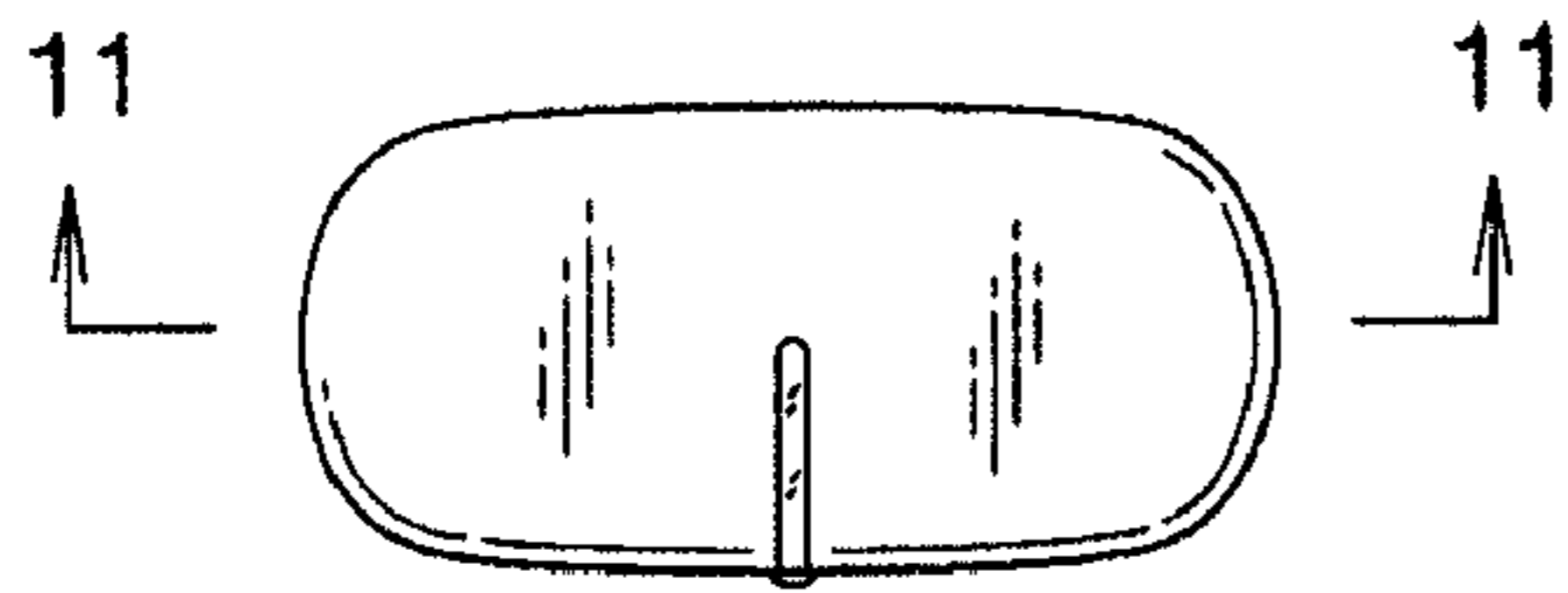

FIG.5



FIG.6

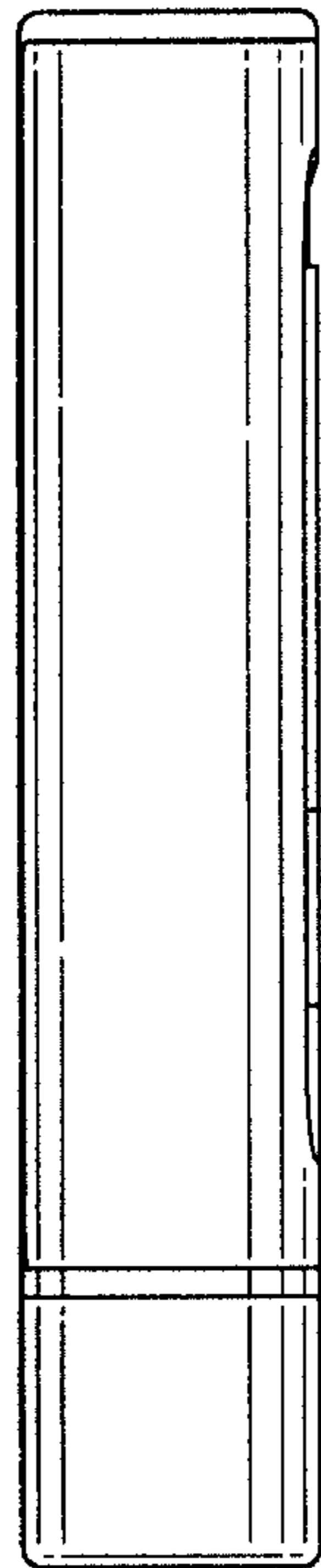

FIG.7

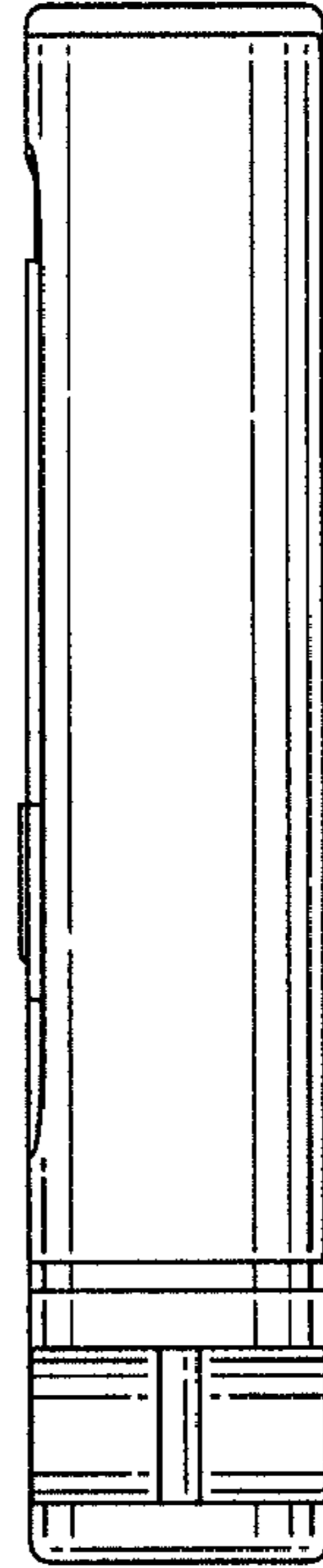

FIG.8

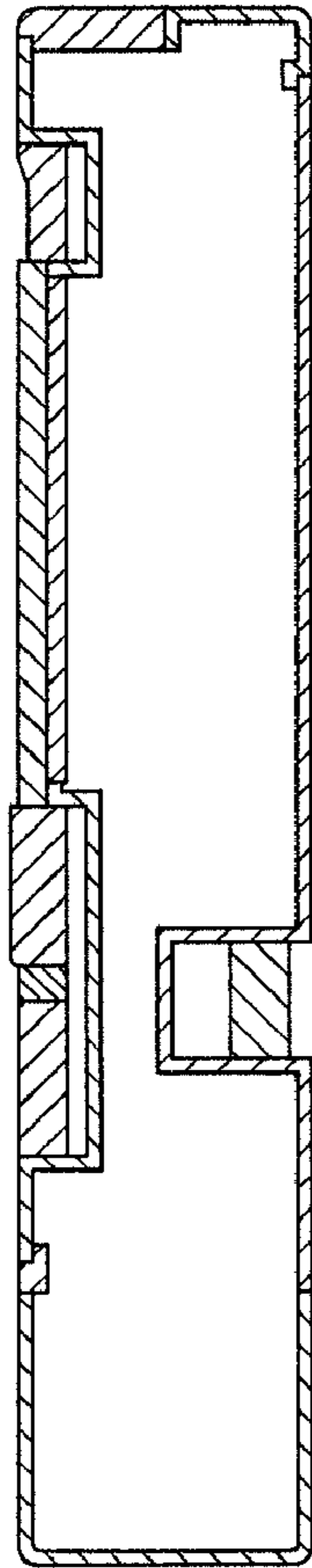

FIG.11

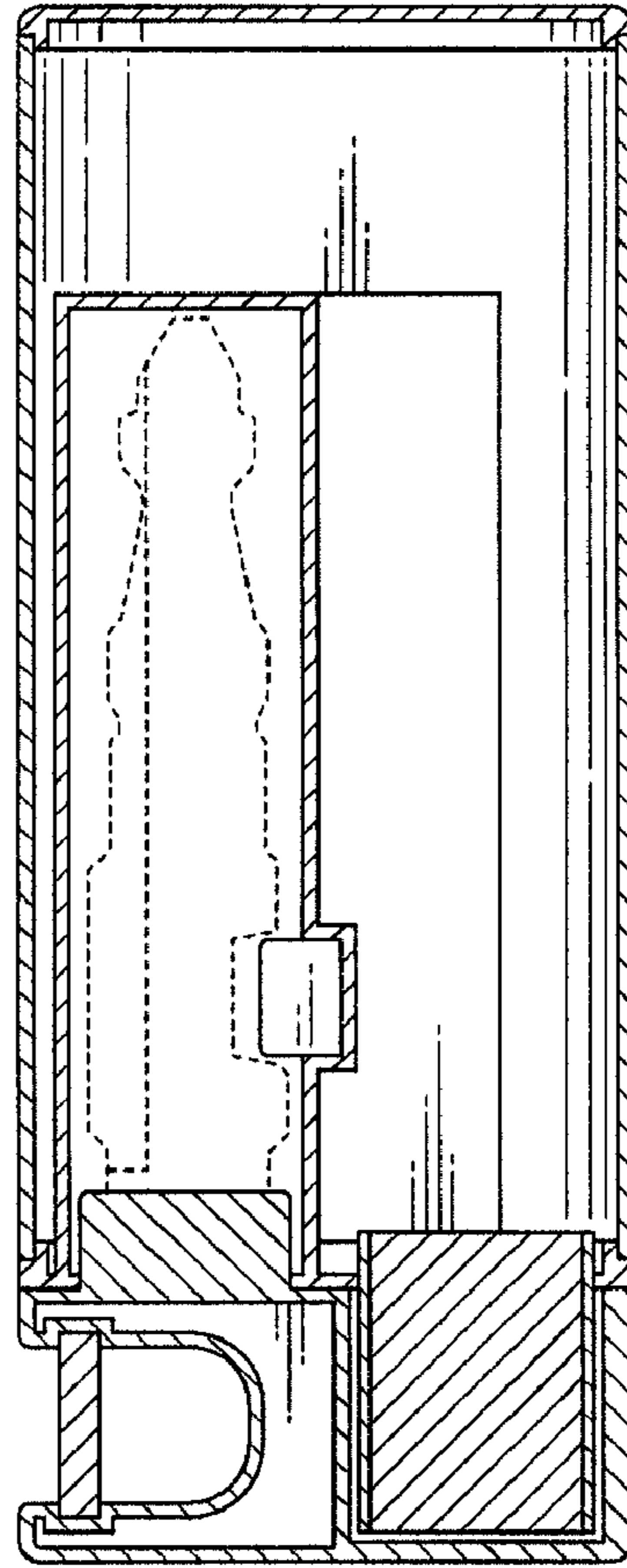

FIG.9

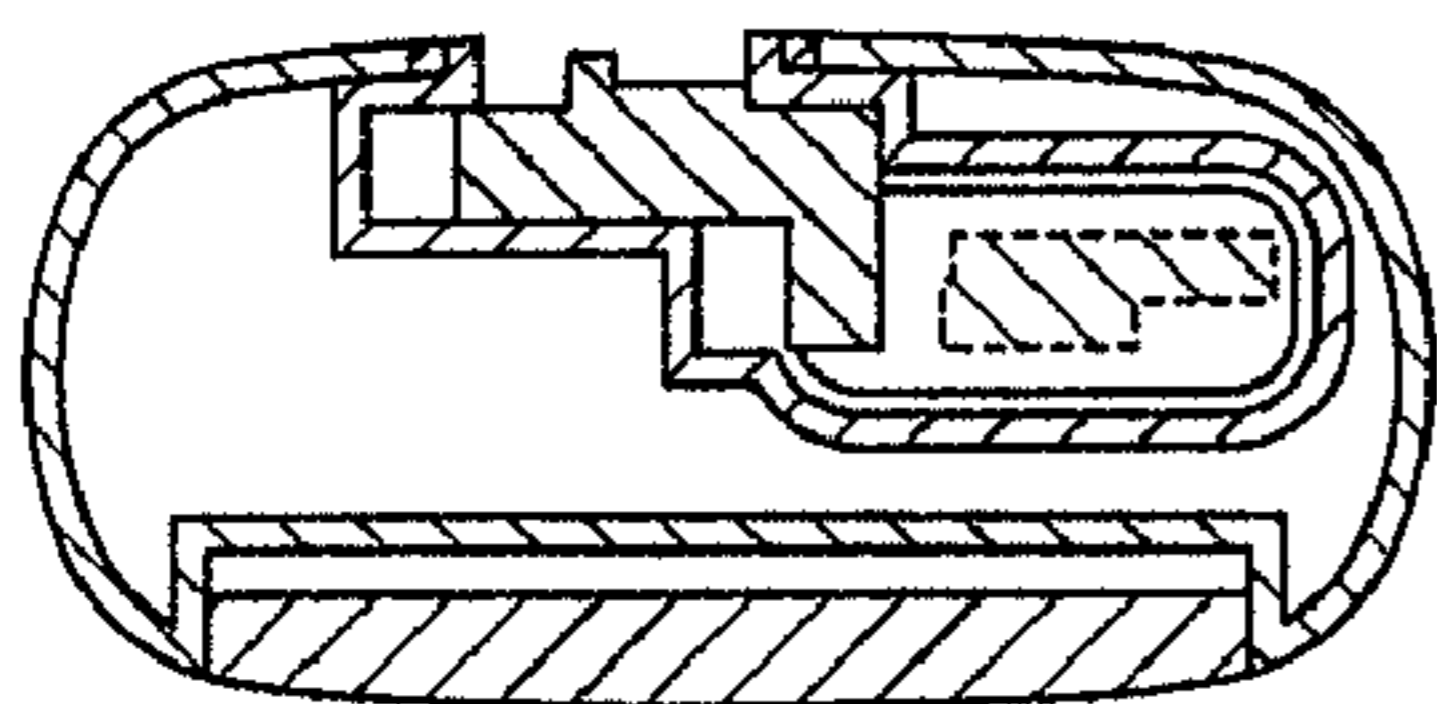

FIG.10

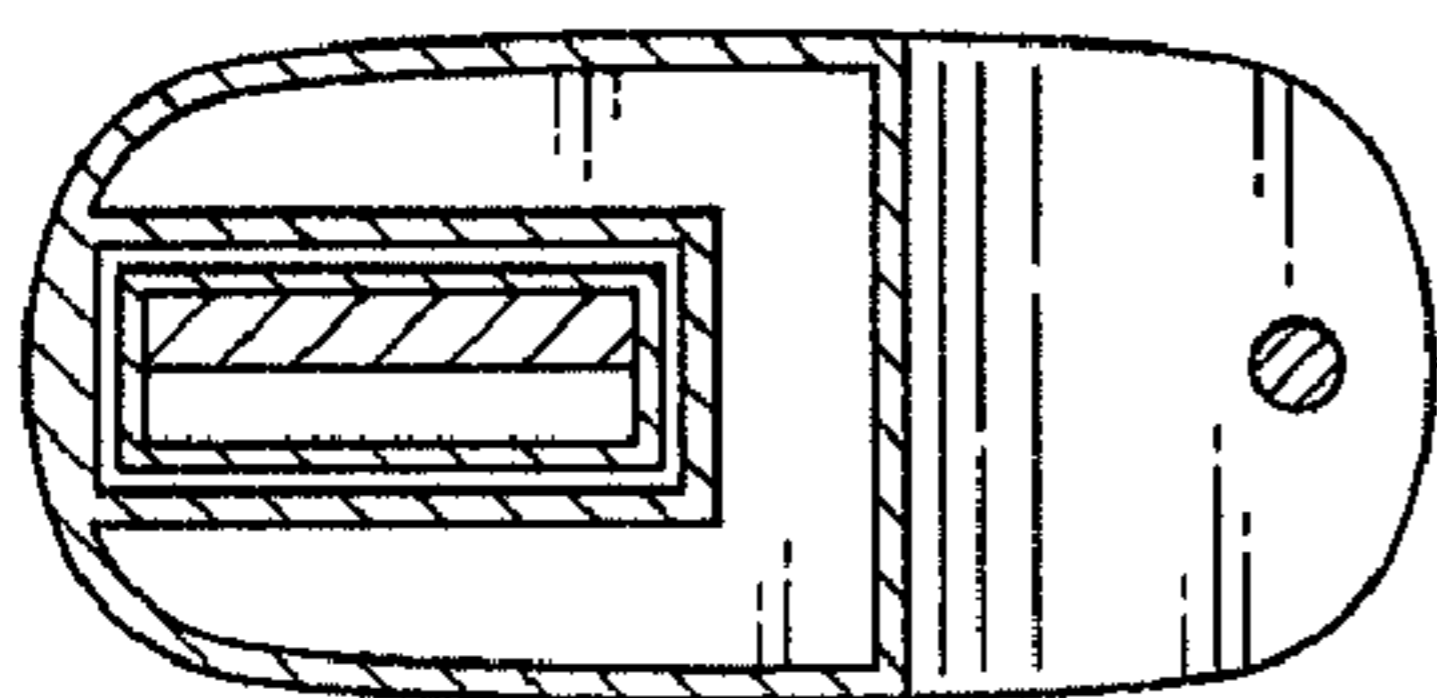

FIG.12

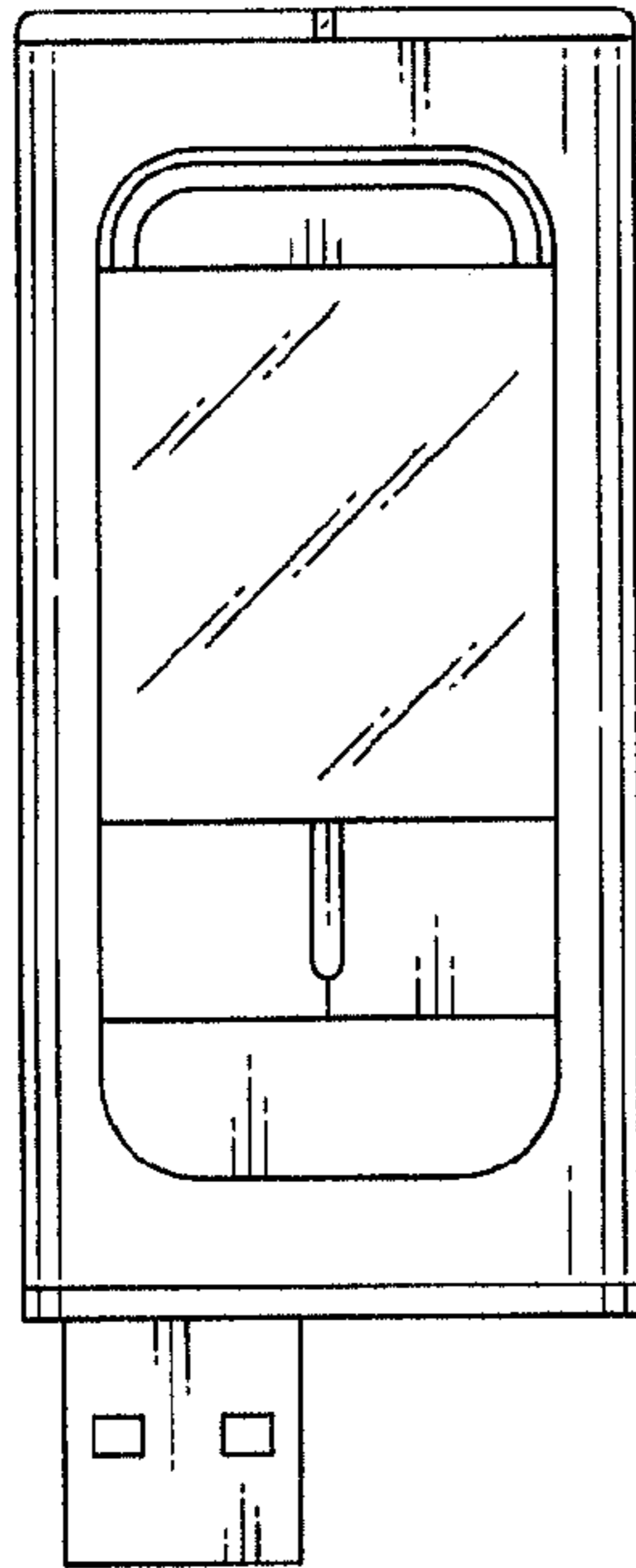

FIG.13

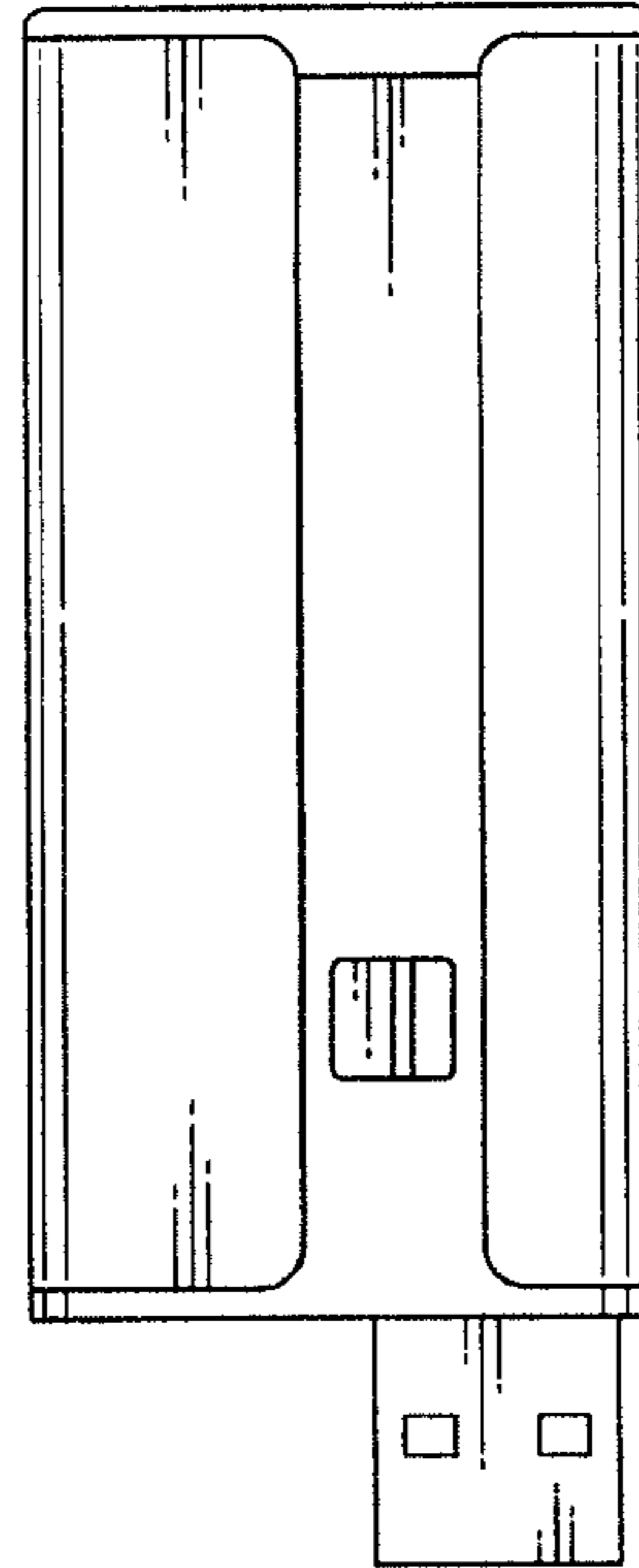

FIG.14

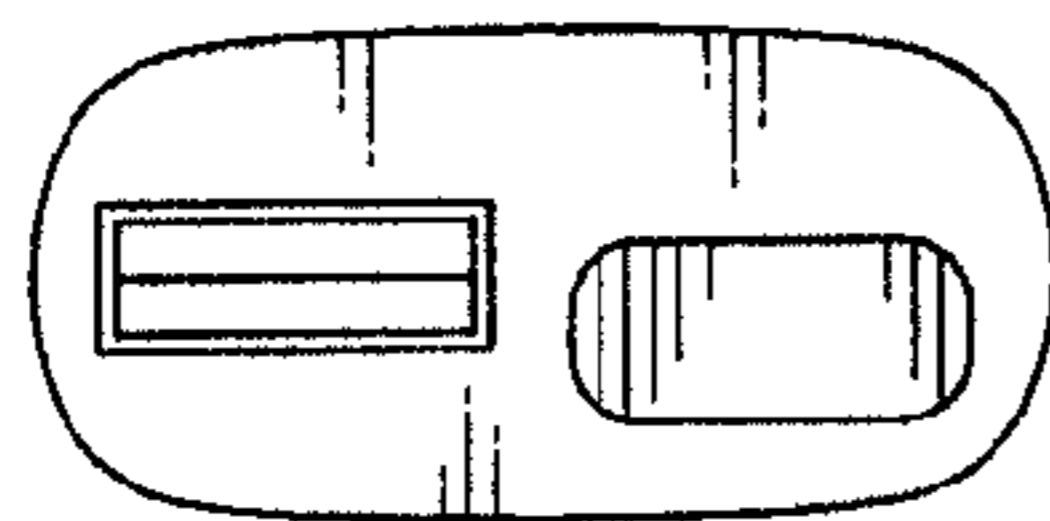

FIG.15

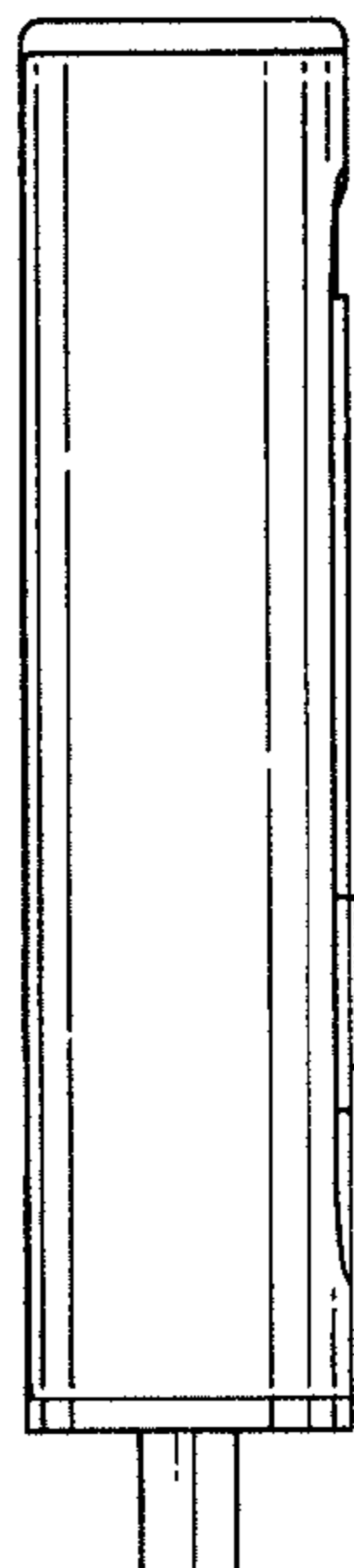

FIG.16

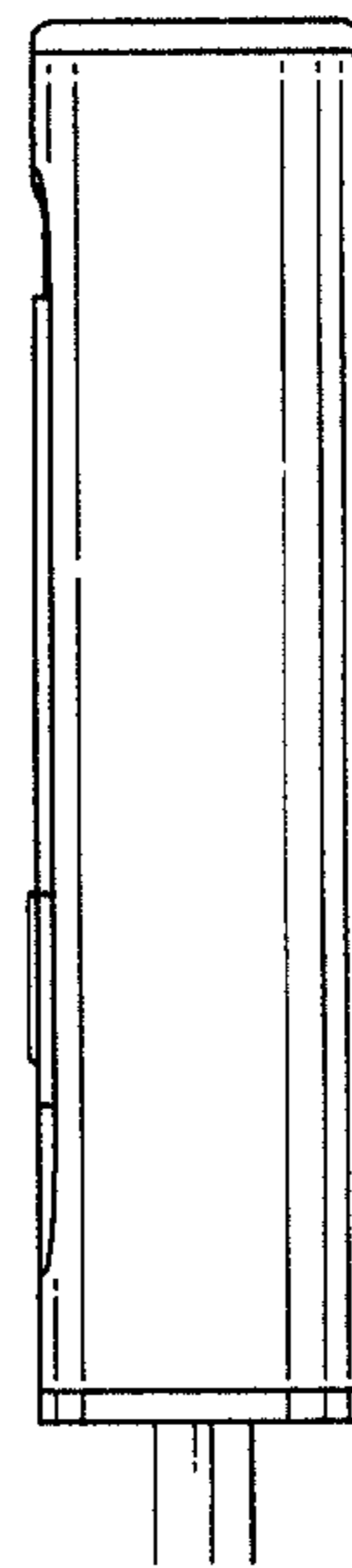

FIG.17

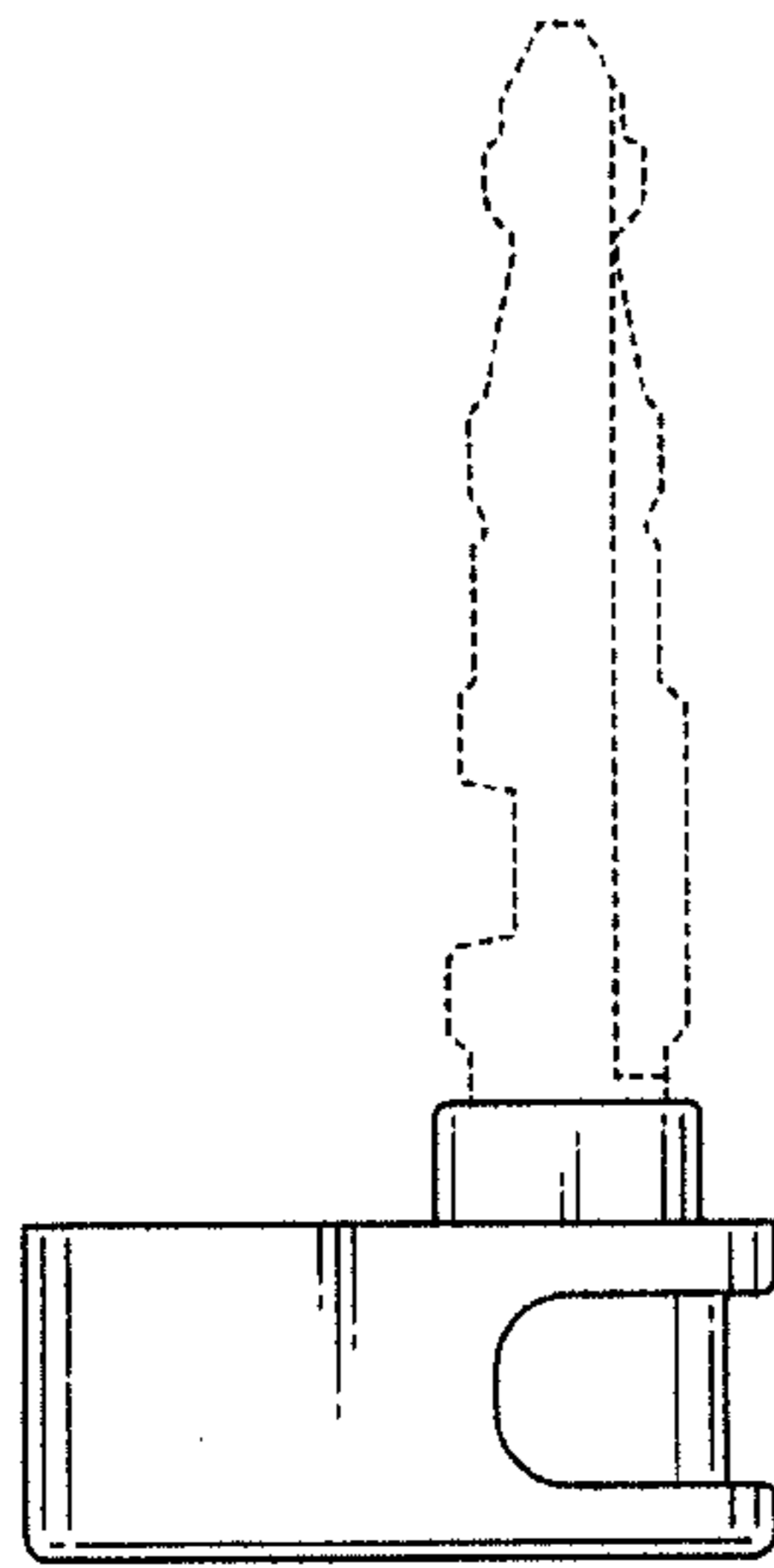

FIG.18

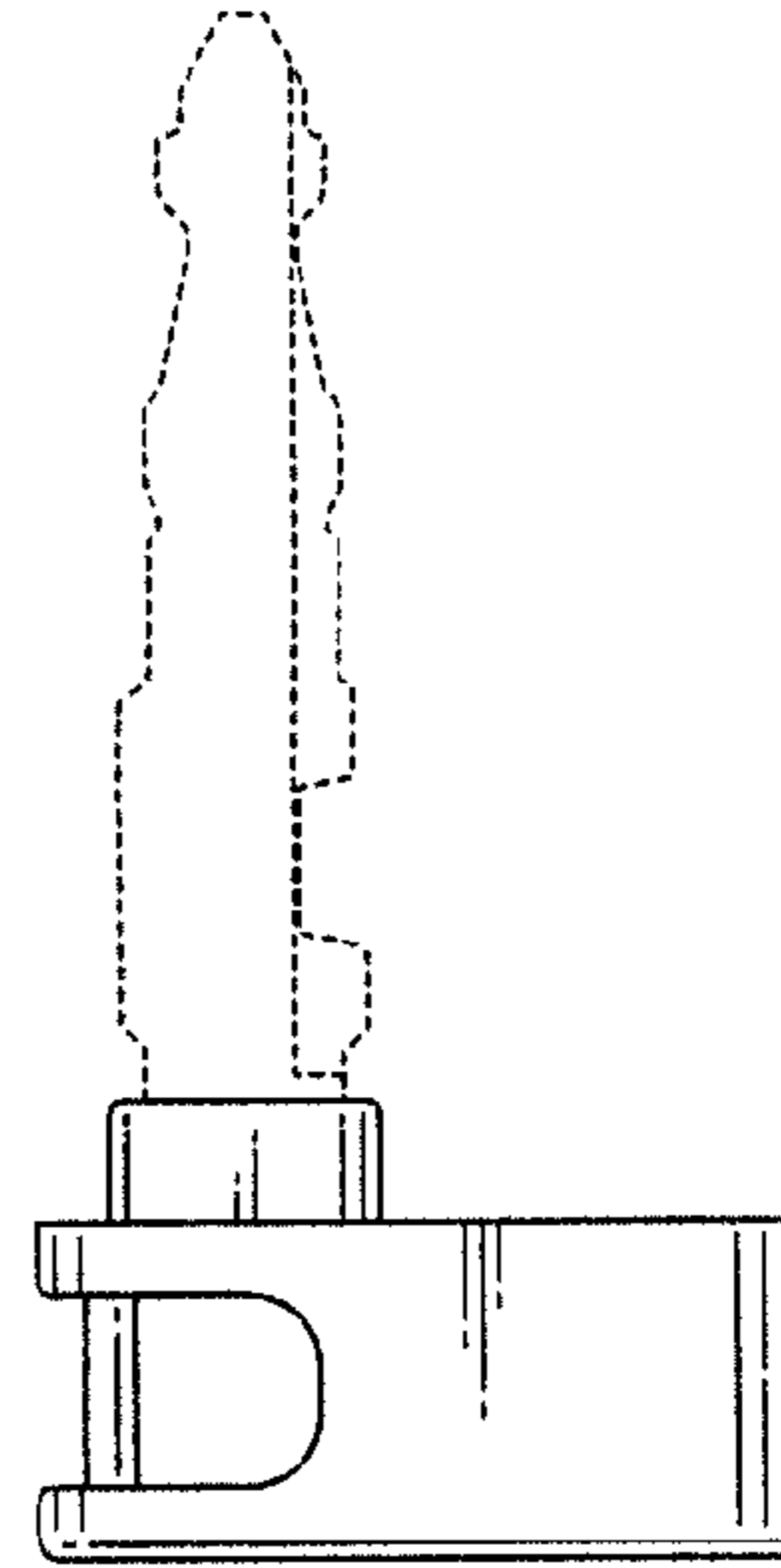

FIG.19

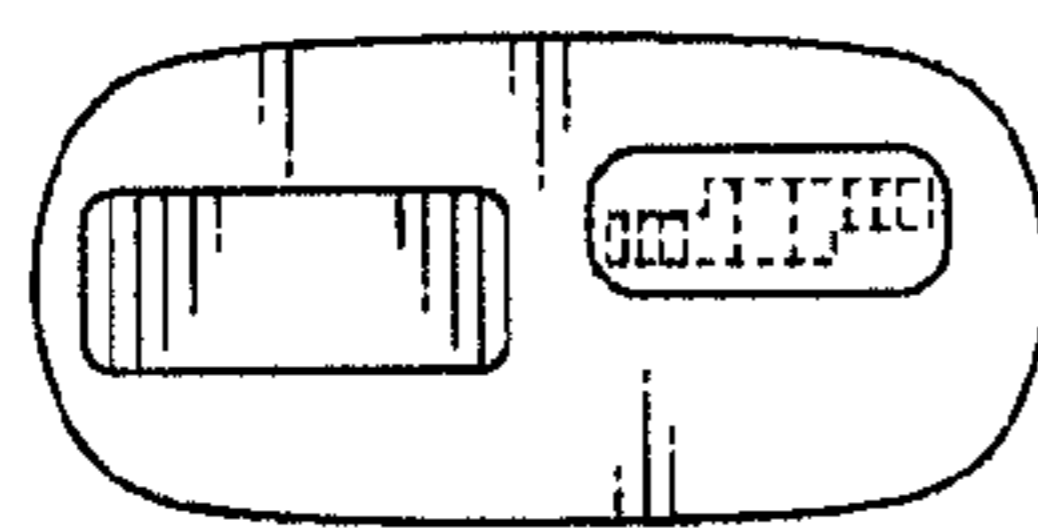

FIG. 20

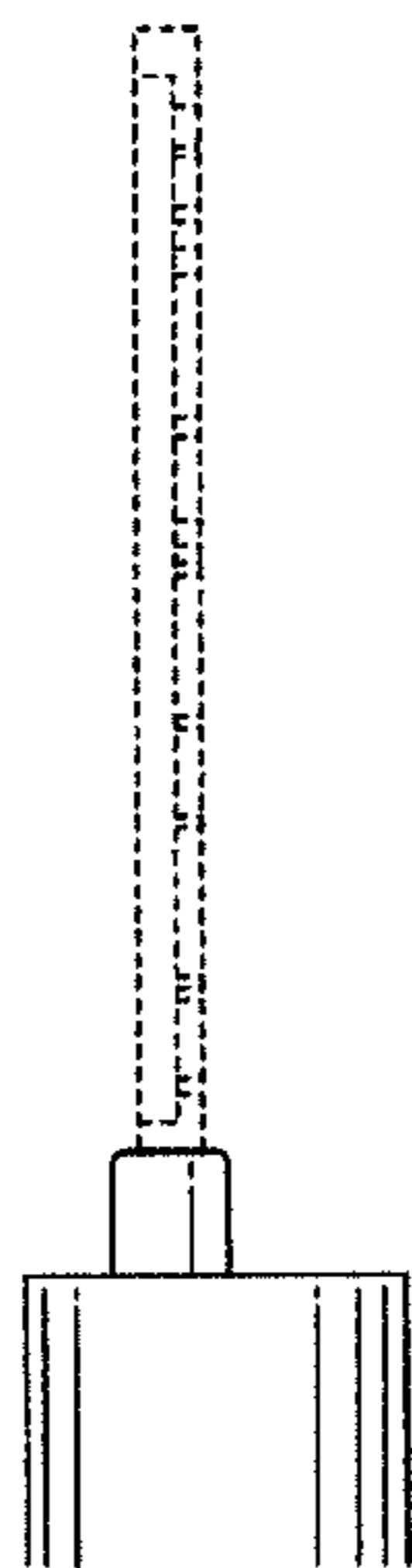

FIG. 21

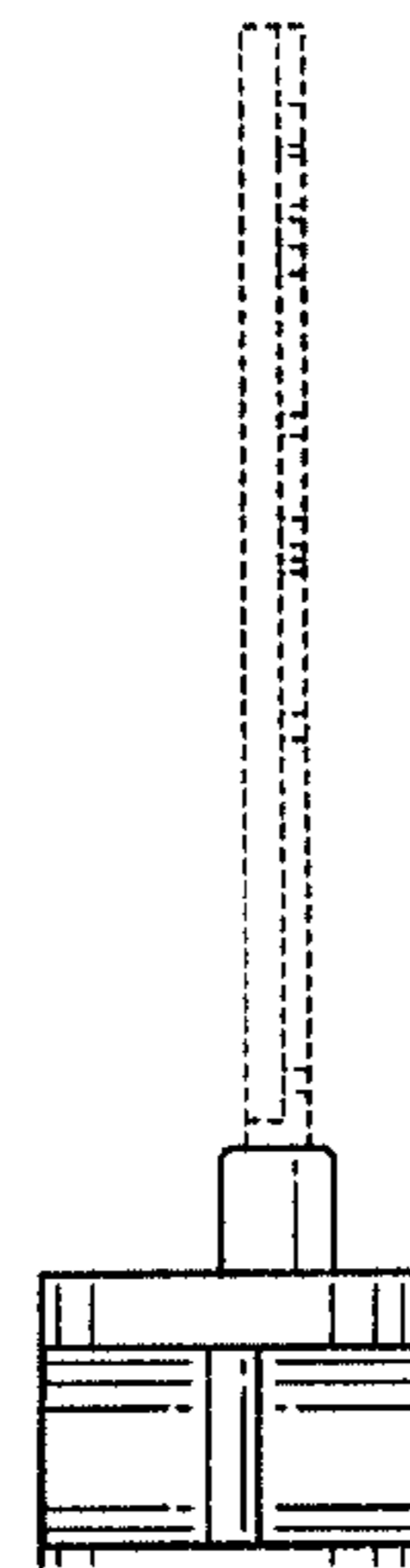

FIG. 22

