



US00D597456S

(12) **United States Design Patent**
Kosaka

(10) **Patent No.:** **US D597,456 S**
(45) **Date of Patent:** **** Aug. 4, 2009**

(54) **PORTION OF AN AUTOMOBILE**

(75) Inventor: **Shiro Kosaka**, Tokyo (JP)

(73) Assignee: **Gallery Abarth Inc.**, Tokyo (JP)

(**) Term: **14 Years**

(21) Appl. No.: **29/283,532**

(22) Filed: **Aug. 16, 2007**

(30) **Foreign Application Priority Data**

Feb. 16, 2007 (JP) 2007-003726

(51) **LOC (9) Cl.** **12-08**

(52) **U.S. Cl.** **D12/181; D12/400; D12/92**

(58) **Field of Classification Search** D12/196,
D12/190, 400, 181, 92, 126; D26/28, 35;
D21/778, 398, 424, 433, 453; D3/211; D10/111;
D13/165; 296/180.1; 441/79

See application file for complete search history.

(56) **References Cited**

U.S. PATENT DOCUMENTS

- D161,000 S * 11/1950 Chika D12/92
- D168,228 S * 11/1952 Kleve D12/92
- D174,776 S * 5/1955 Sipple D26/28
- D180,128 S * 4/1957 Weissinger D12/92
- D183,632 S * 9/1958 Reynolds D12/92
- D185,843 S * 8/1959 James D12/92
- D192,214 S * 2/1962 Walker D12/190
- D192,497 S * 4/1962 Bailey D12/92
- D220,137 S * 3/1971 Kwiatkowski D21/778
- 3,861,735 A * 1/1975 Taylor 296/180.1
- D261,448 S * 10/1981 Liebscher D3/211
- 5,810,424 A * 9/1998 Kuttner et al. 296/180.1
- 6,439,940 B1 * 8/2002 Pouchkarev 441/79
- D466,447 S * 12/2002 Stoddard et al. D12/92
- D562,745 S * 2/2008 Schowalter et al. D12/179

D570,945 S * 6/2008 Stagnaro D21/778

* cited by examiner

Primary Examiner—Robert M Spear

Assistant Examiner—Cynthia Underwood

(74) *Attorney, Agent, or Firm*—Banner & Witcoff, Ltd.

(57) **CLAIM**

The ornamental design for a portion of an automobile, as shown and described.

DESCRIPTION

FIG. 1 is a front, top and left side perspective view of a portion of an automobile, showing my new design;

FIG. 2 is a front elevational view thereof;

FIG. 3 is a rear elevational view thereof;

FIG. 4 is a top plan view thereof;

FIG. 5 is a bottom plan view thereof;

FIG. 6 is a left side elevational view thereof;

FIG. 7 is a right side elevational view thereof;

FIG. 8 is an enlarged fragmented elevational view thereof, taken along the line 8—8 in FIG. 2;

FIG. 9 is an enlarged fragmented elevational view thereof, taken along the line 9—9 in FIG. 7;

FIG. 10 is an enlarged fragmented elevational view thereof, taken along the line 10—10 in FIG. 6;

FIG. 11 is an enlarged fragmented front perspective view thereof, taken along the line 8—8 in FIG. 2; and,

FIG. 12 is an enlarged fragmented rear perspective view thereof, taken along the line 8—8 in FIG. 2.

The dash and dotted lines immediately adjacent the shaded areas represent the bounds of the claimed design while all other broken lines are directed to environment and are for illustrative purposes only; the broken lines form no part of the claimed design.

1 Claim, 8 Drawing Sheets

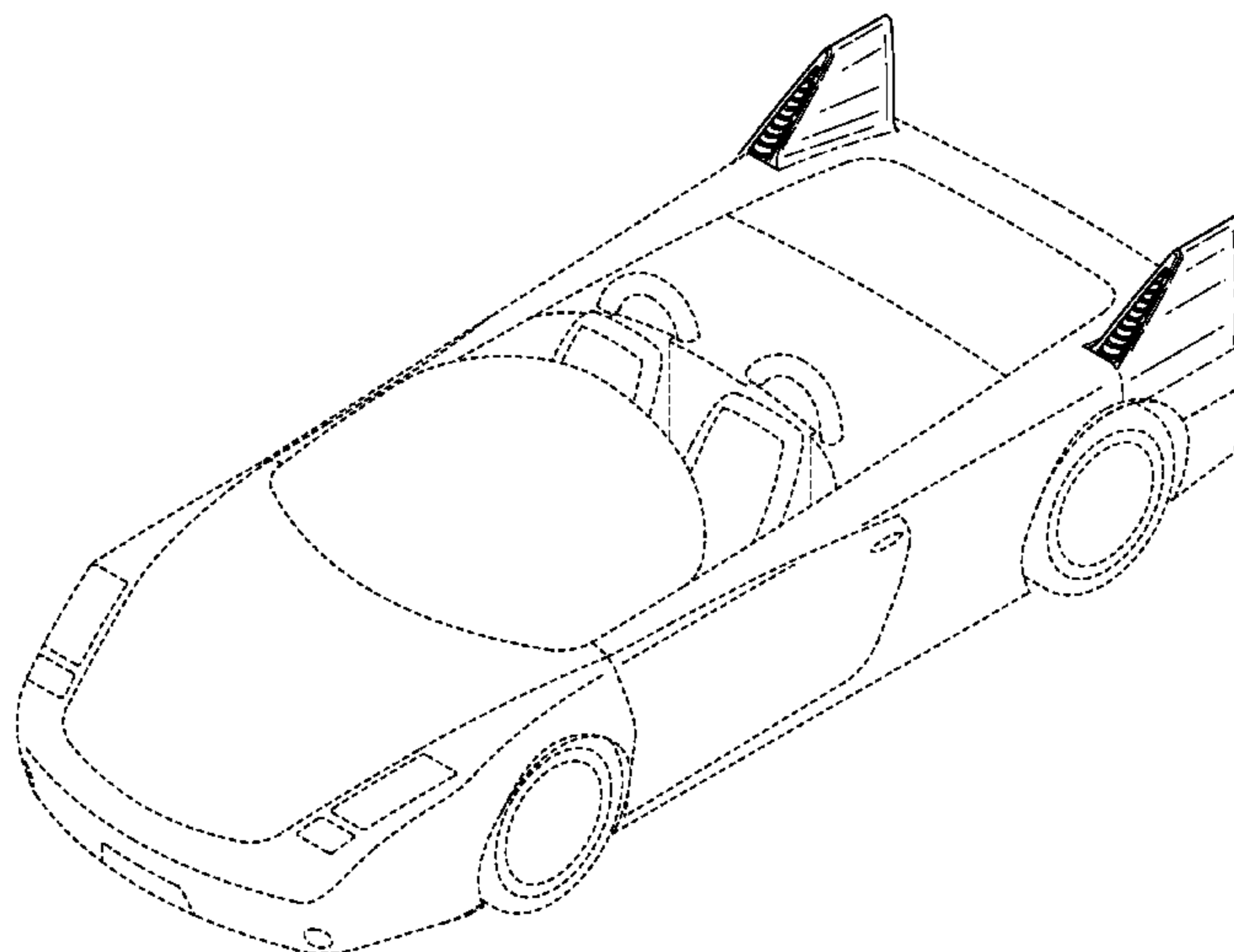

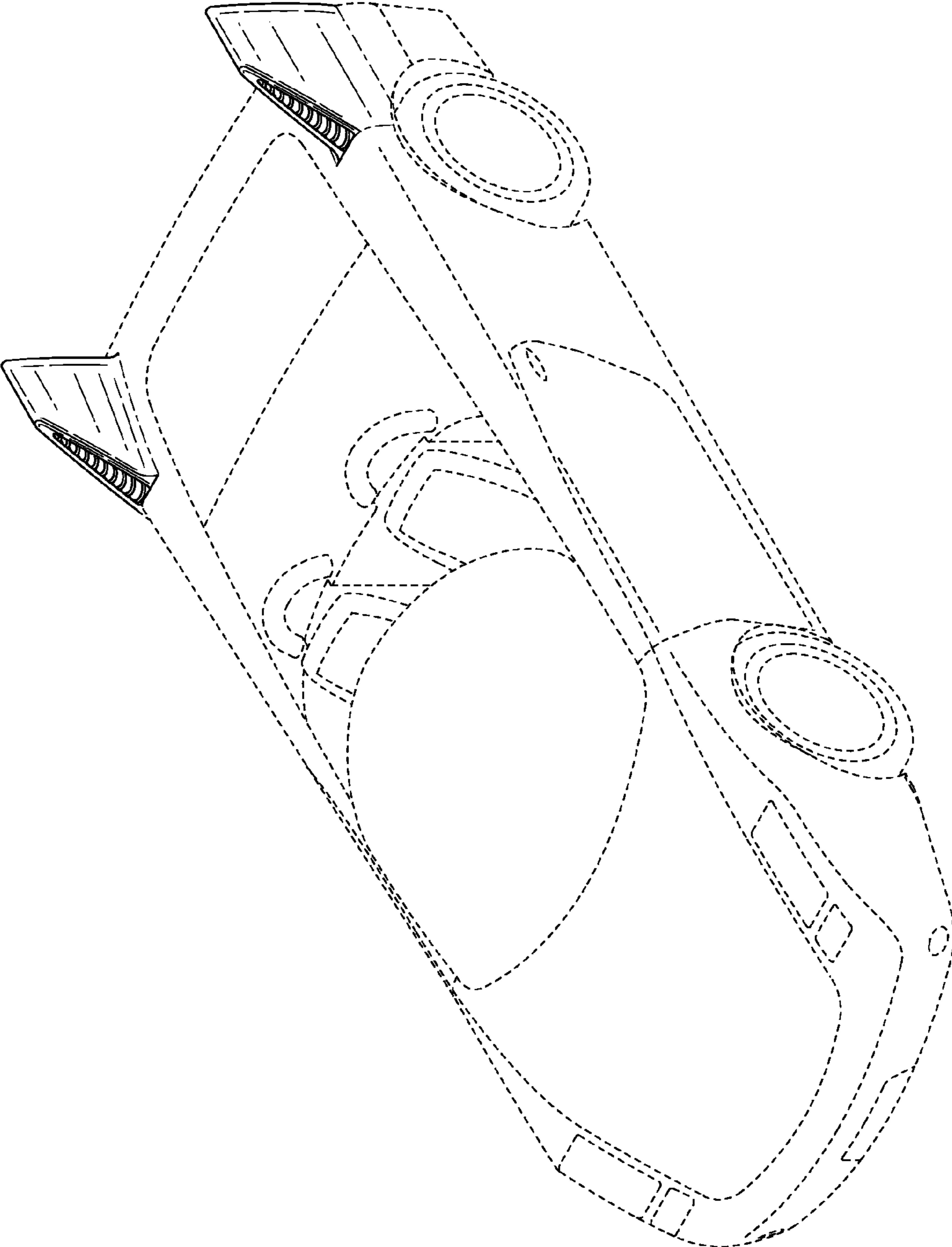

FIG. 1

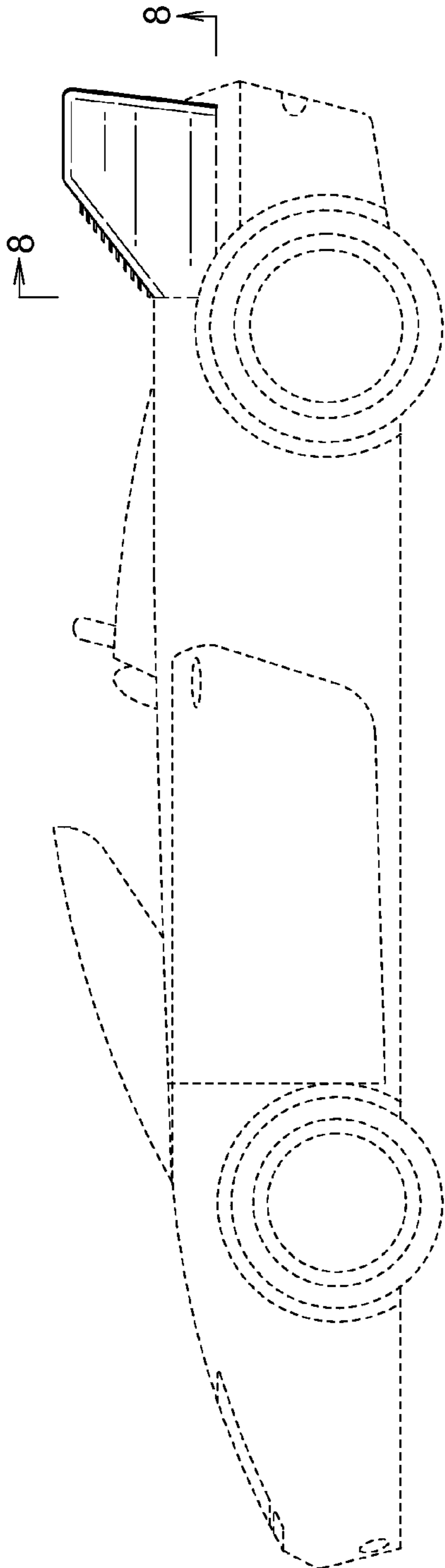

FIG. 2

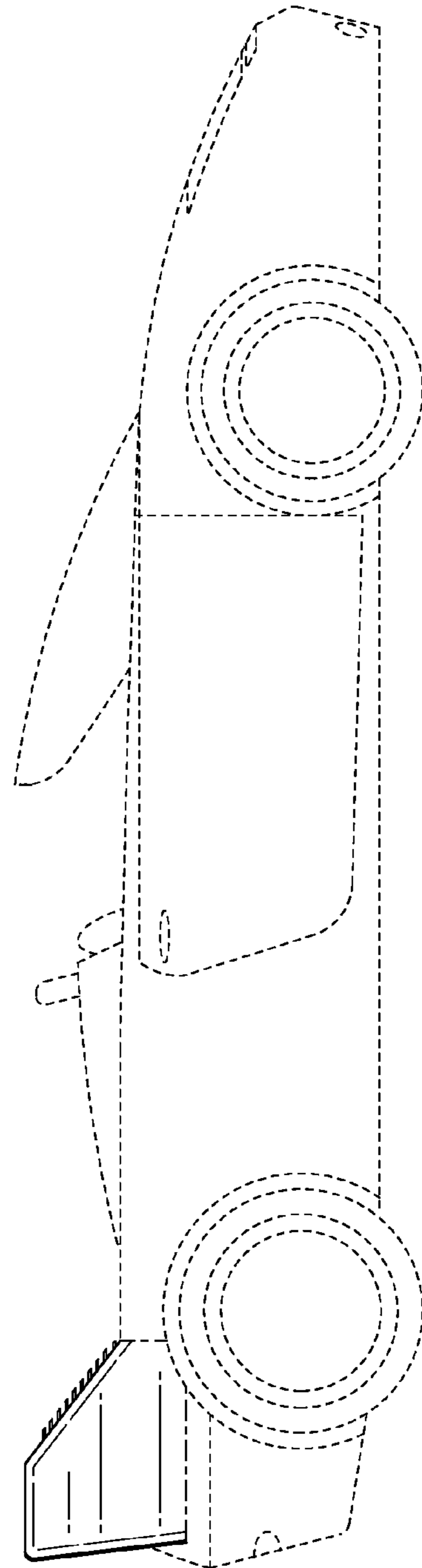

FIG. 3

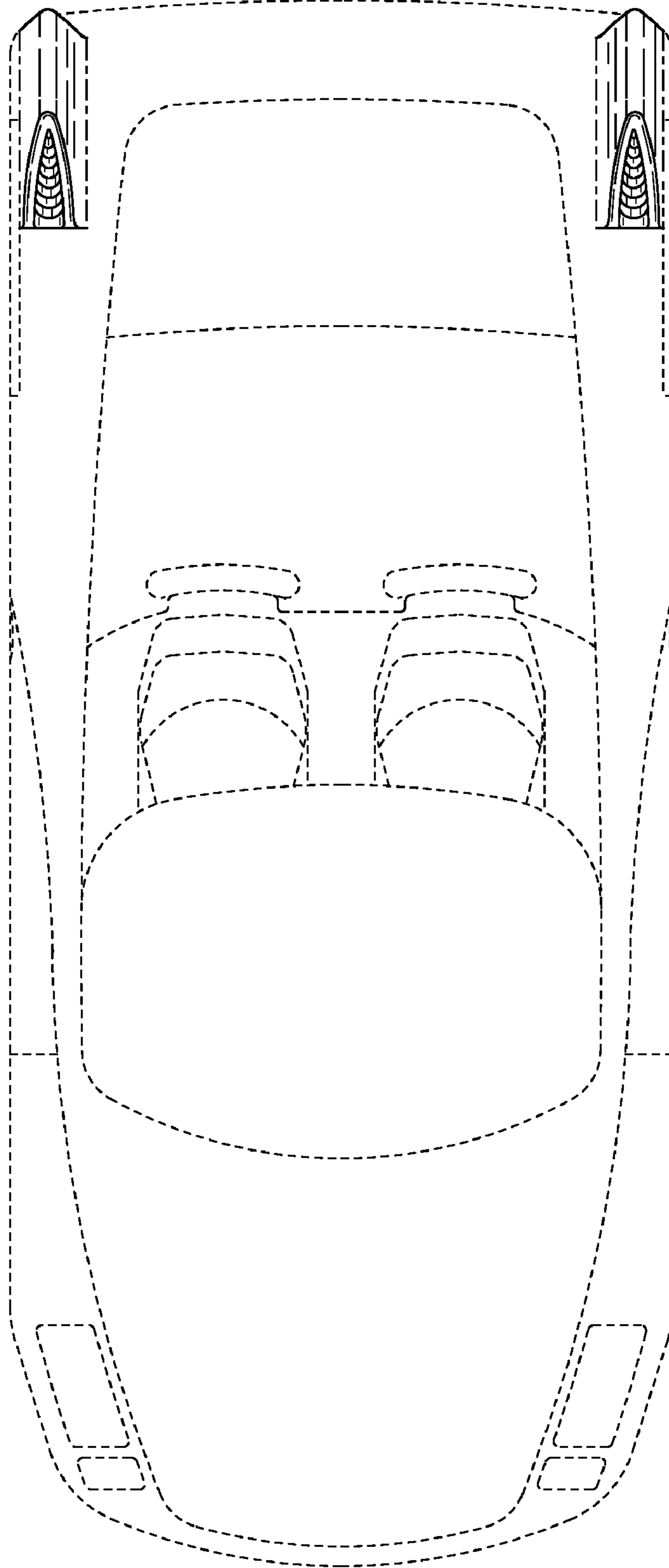

FIG. 4

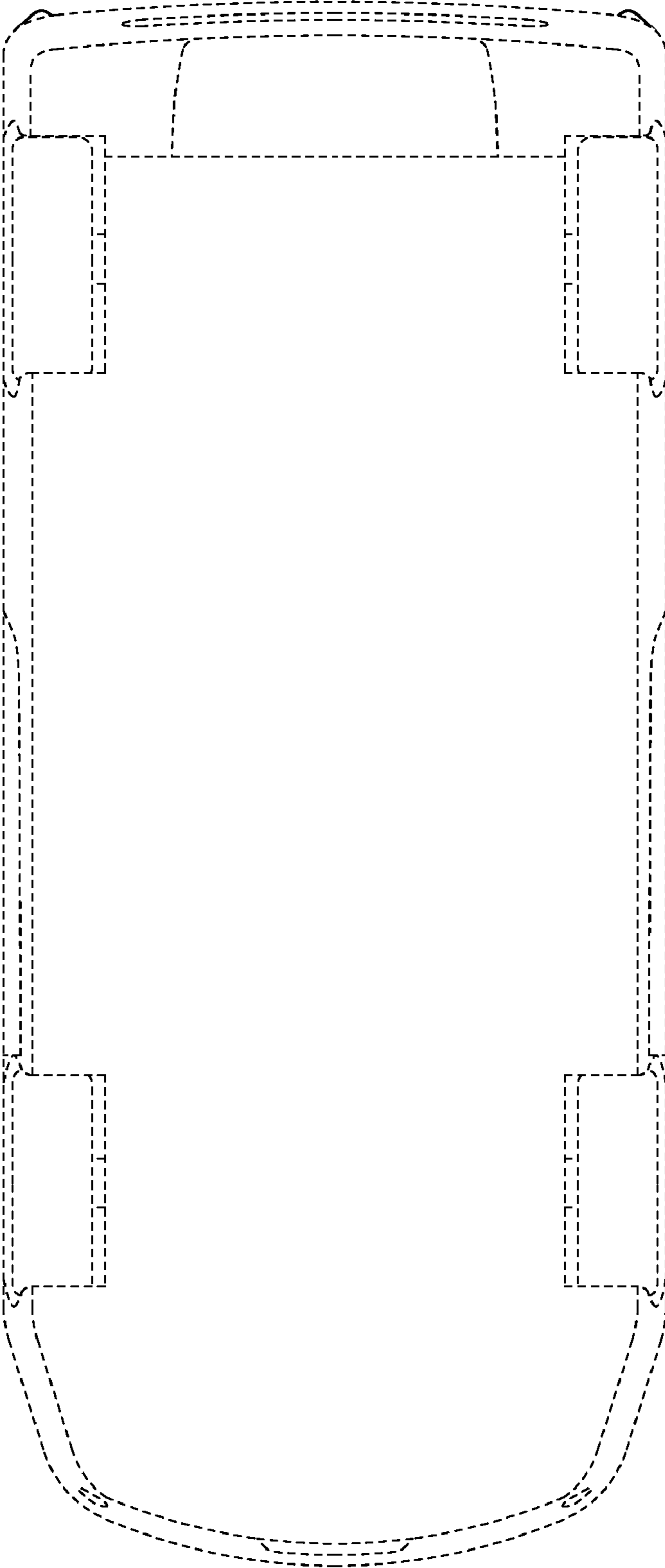

FIG. 5

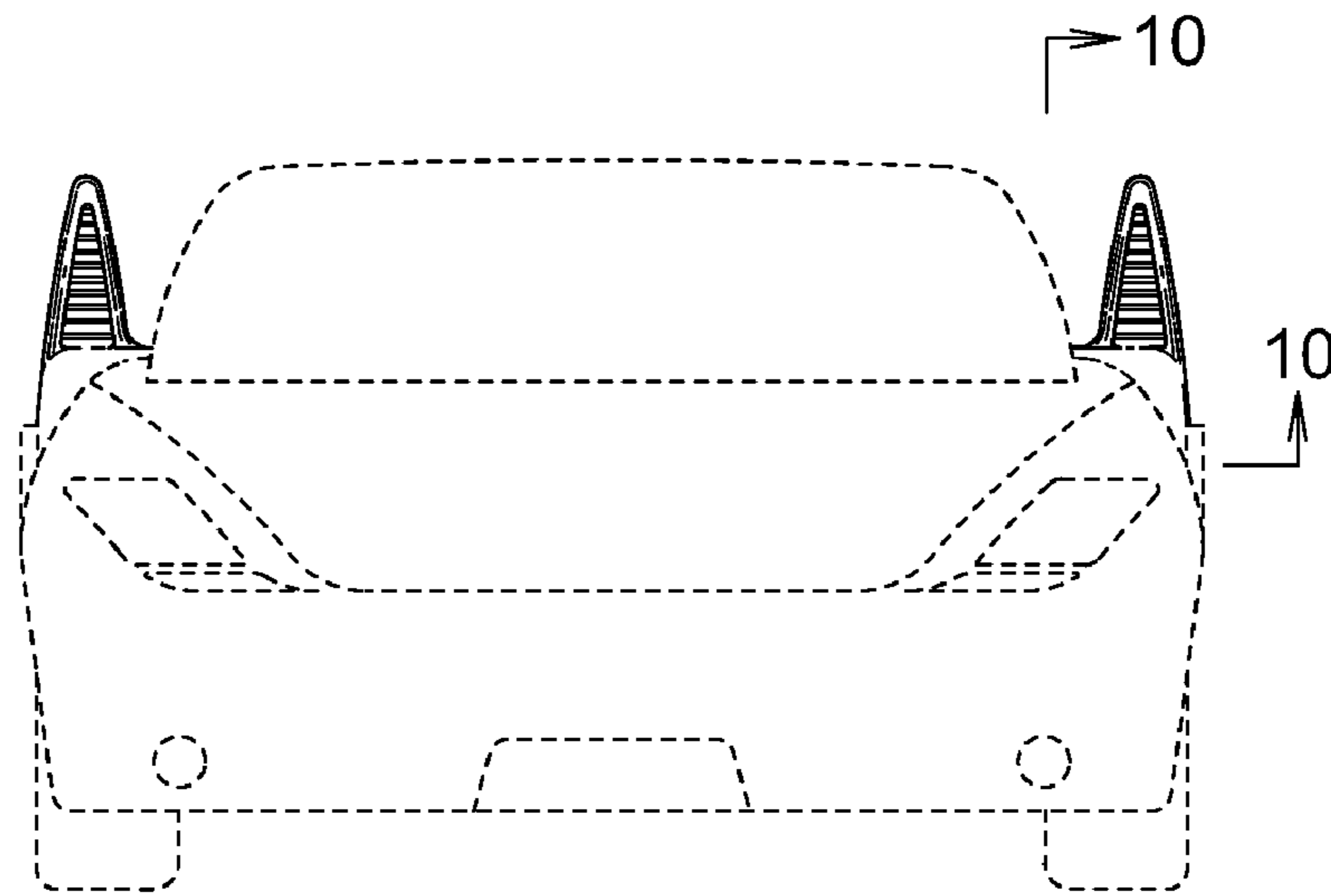

FIG. 6

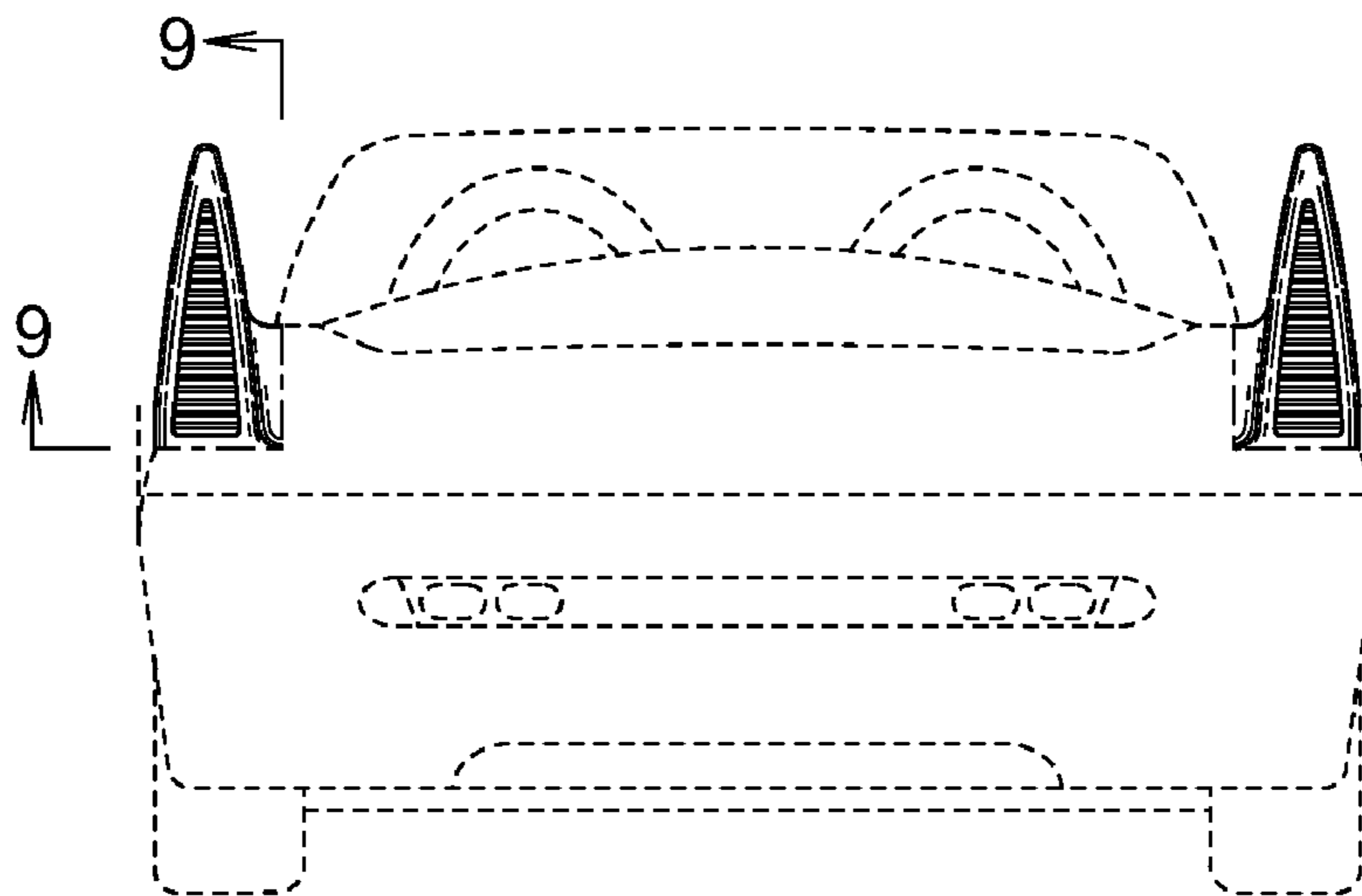

FIG. 7

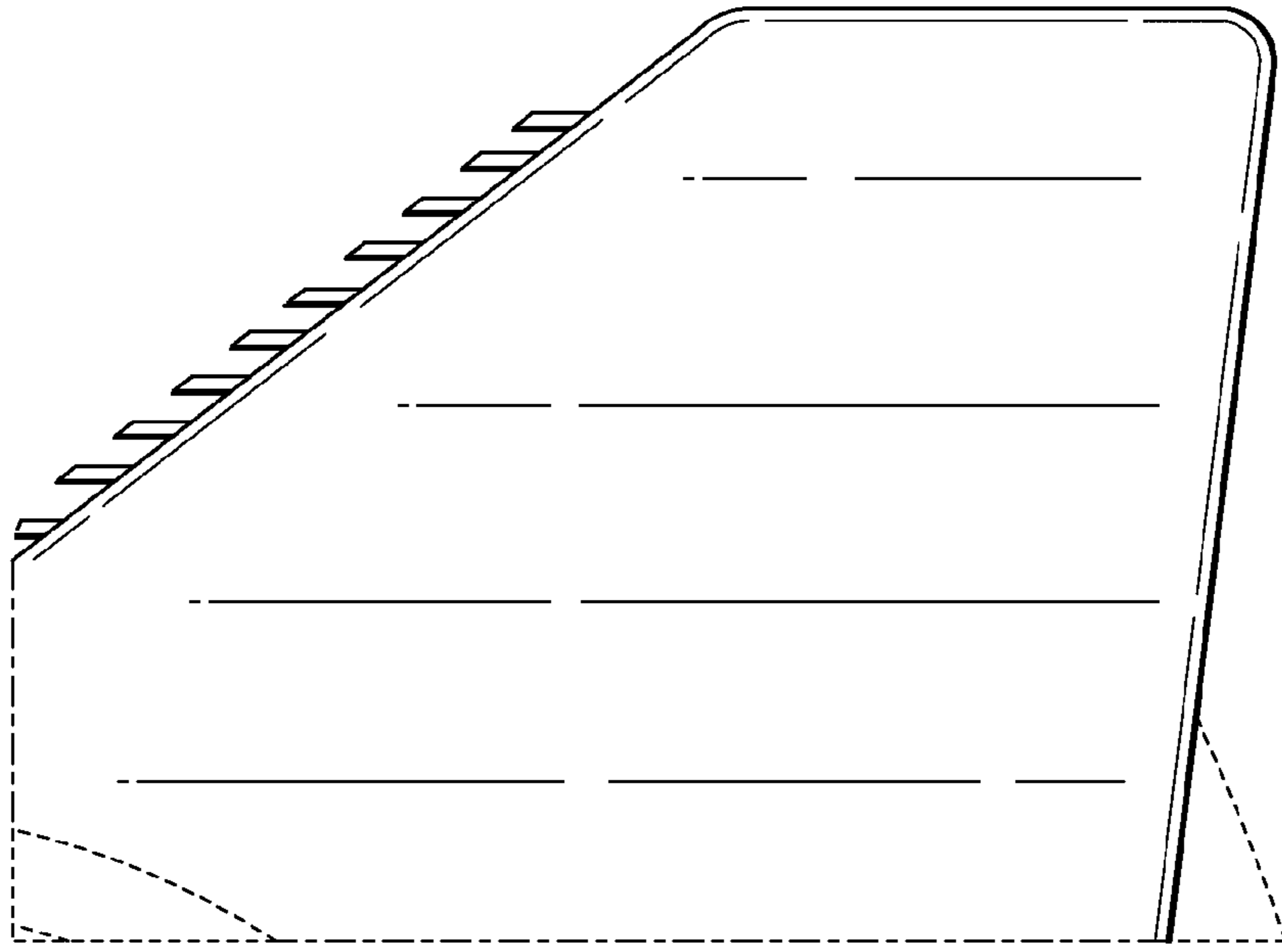

FIG. 8

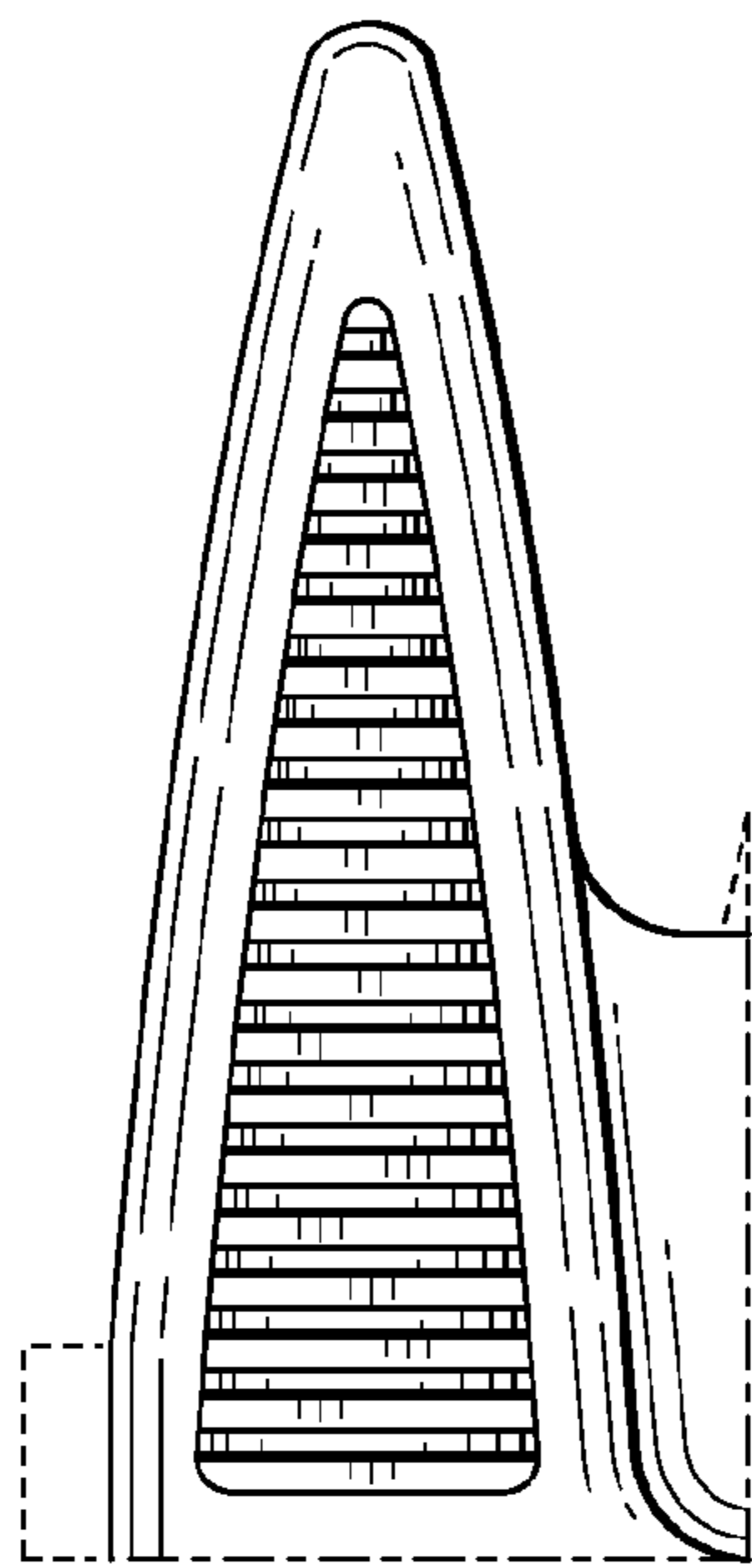

FIG. 9

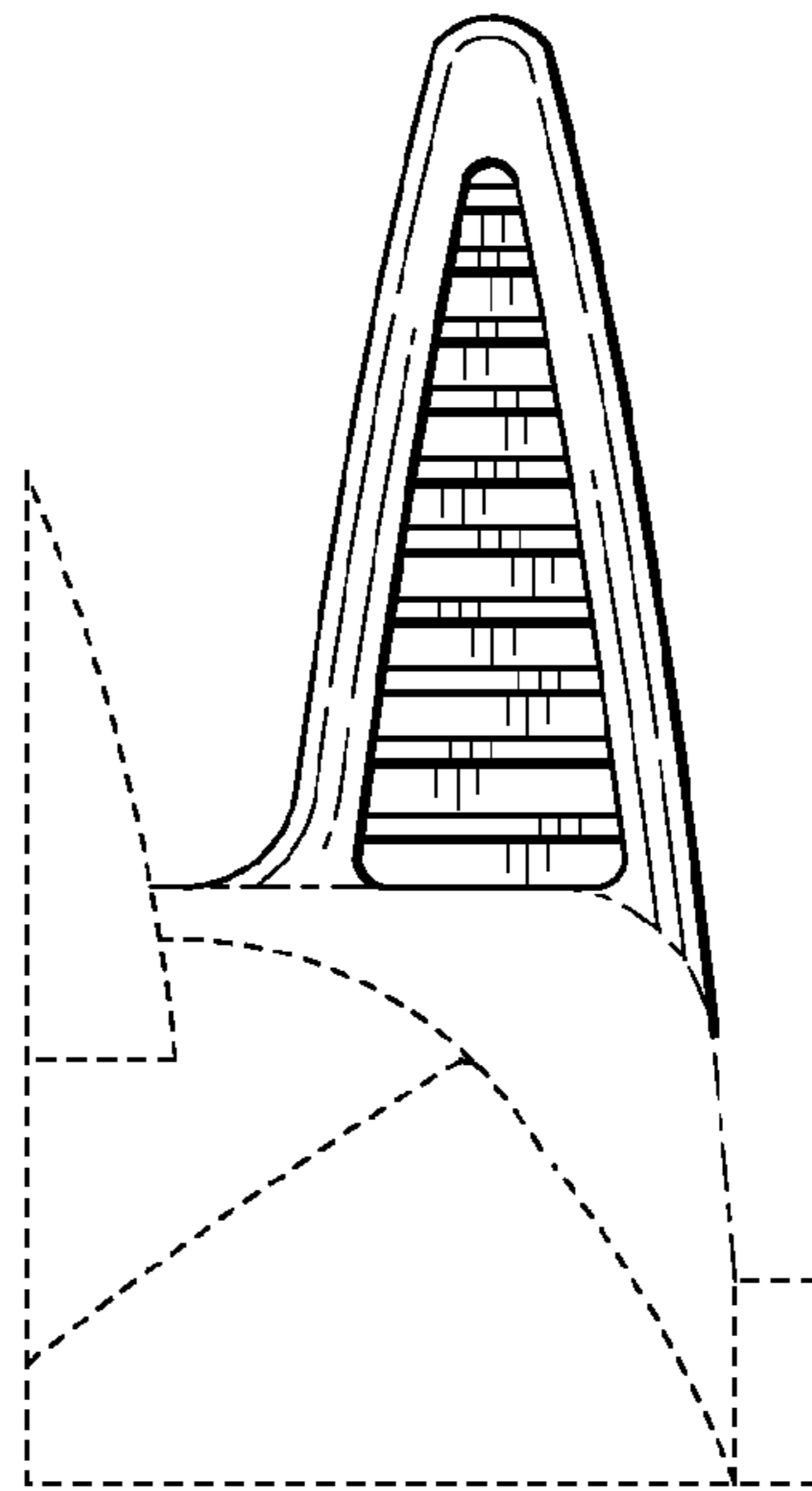

FIG. 10

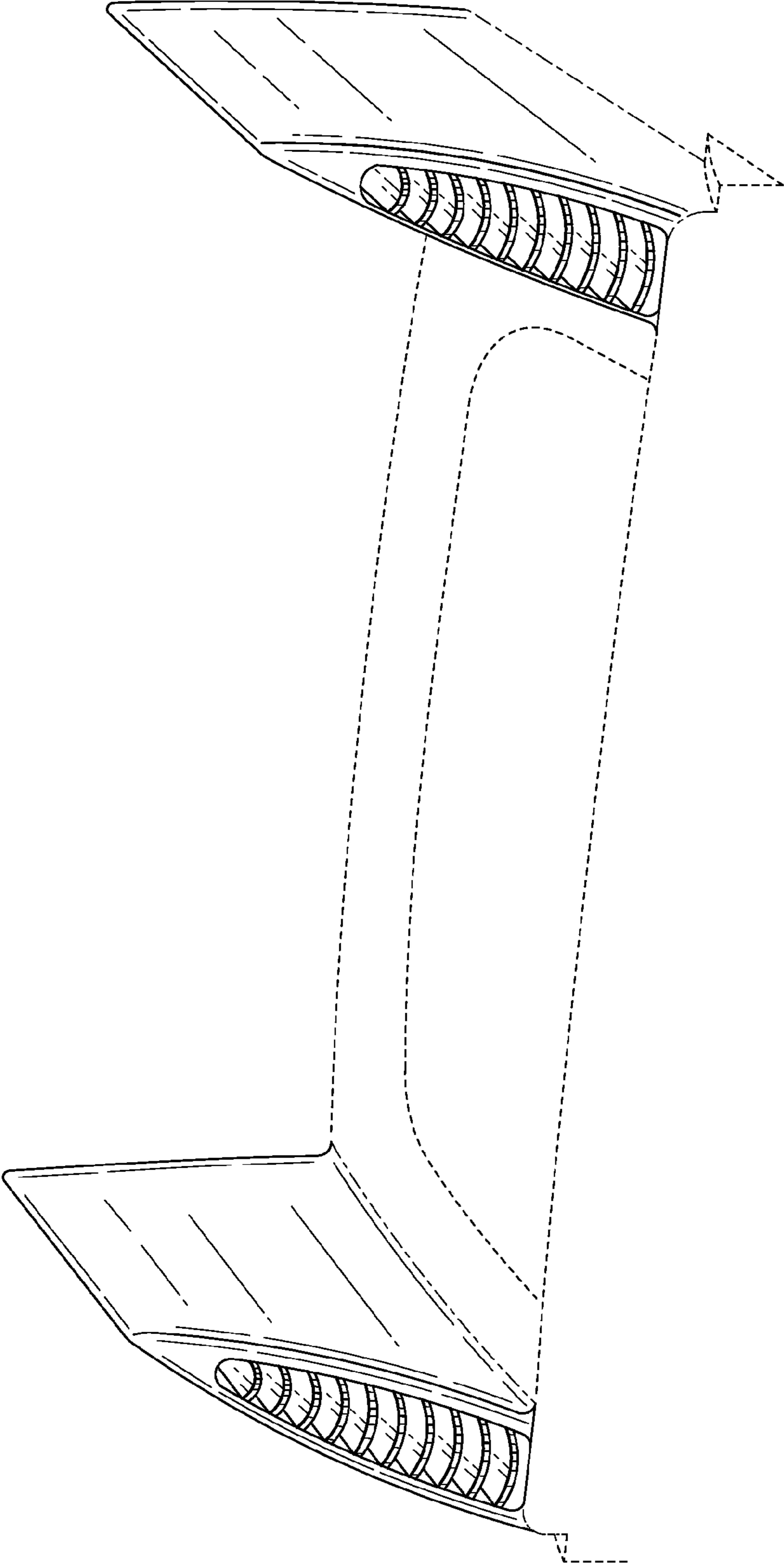

FIG. 11

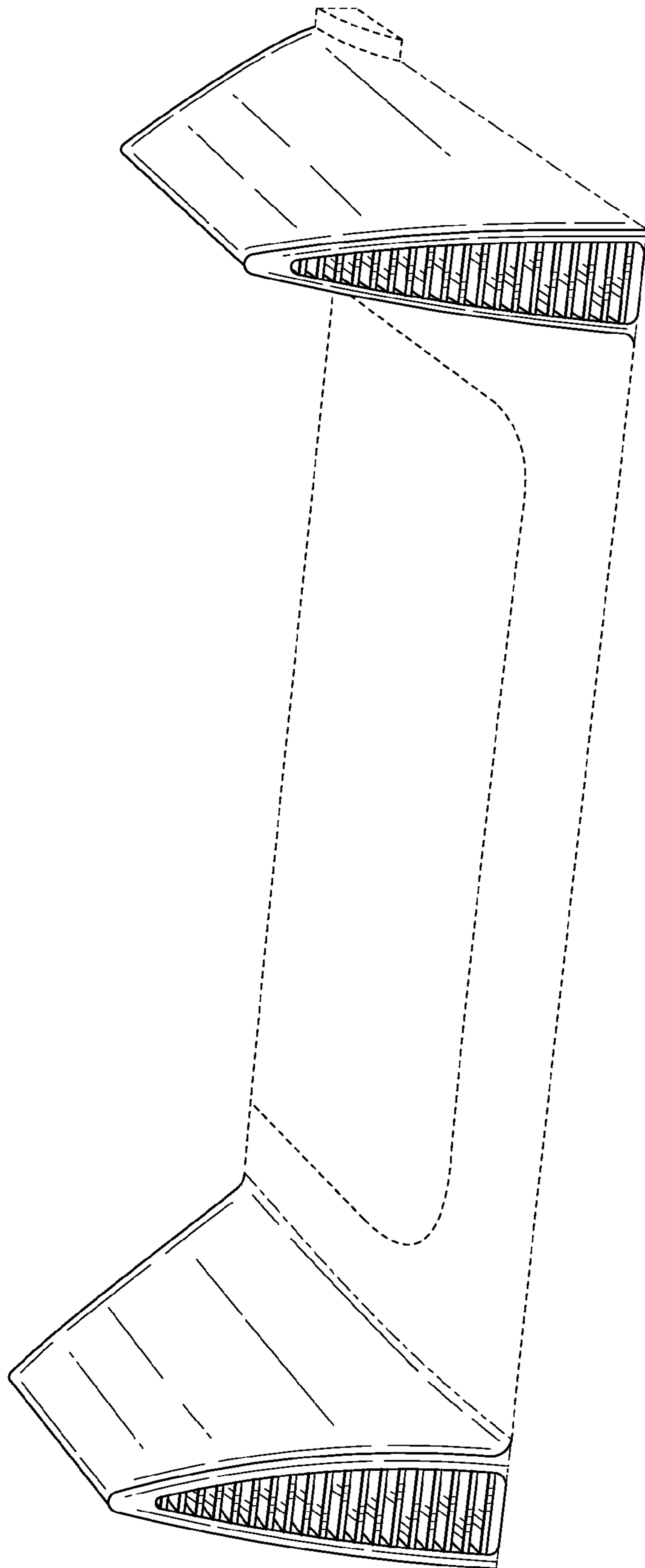

FIG. 12