



US00D597431S

(12) **United States Design Patent**
Aikawa

(10) **Patent No.:** **US D597,431 S**

(45) **Date of Patent:** **** Aug. 4, 2009**

(54) **REMOTE CONTROLLER FOR VEHICLES**

(75) Inventor: **Masami Aikawa**, Chiyoda-Ku (JP)

(73) Assignee: **Mitsubishi Electric Corporation**,
Tokyo (JP)

(**) Term: **14 Years**

(21) Appl. No.: **29/325,923**

(22) Filed: **Oct. 8, 2008**

(30) **Foreign Application Priority Data**

Apr. 9, 2008 (JP) 2008-009074

(51) **LOC (9) Cl.** **10-05**

(52) **U.S. Cl.** **D10/104**

(58) **Field of Classification Search** D10/104,
D10/106; D13/168, 207; D14/218, 138,
D14/154, 168, 188; 362/157, 116, 200, 186,
362/87; D26/37, 38, 63; 455/351, 350; 340/426.31,
340/546, 628, 815.4, 815.73

See application file for complete search history.

(56) **References Cited**

U.S. PATENT DOCUMENTS

D304,310 S * 10/1989 Calis D10/106
D470,743 S * 2/2003 Koy D8/334

OTHER PUBLICATIONS

“Remote Control Key for Volvo S80,” Catalogue of Volvo Corporation, The Instruction Manual of Volvo S80, 2007, p. 42-57.

* cited by examiner

Primary Examiner—Caron Veynar
Assistant Examiner—George D Kirschbaum
(74) *Attorney, Agent, or Firm*—Sughrue Mion, PLLC

(57) **CLAIM**

The ornamental design for a remote controller for vehicles, as shown and described.

DESCRIPTION

FIG. 1 is a front, top and right side perspective view of a remote controller for vehicles, showing my new design;

FIG. 2 is a front elevational view thereof;

FIG. 3 is a rear elevational view thereof;

FIG. 4 is a top plan view thereof;

FIG. 5 is a bottom plan view thereof;

FIG. 6 is a left side elevational view thereof;

FIG. 7 is a right side elevational view thereof;

FIG. 8 is a cross-sectional view thereof; taken along line 8-8 of FIG. 2;

FIG. 9 is a cross-sectional view thereof; taken along line 9-9 of FIG. 4; and,

FIG. 10 is a reference bottom view showing the light-transmitting portion of the design in a lighted state.

1 Claim, 3 Drawing Sheets

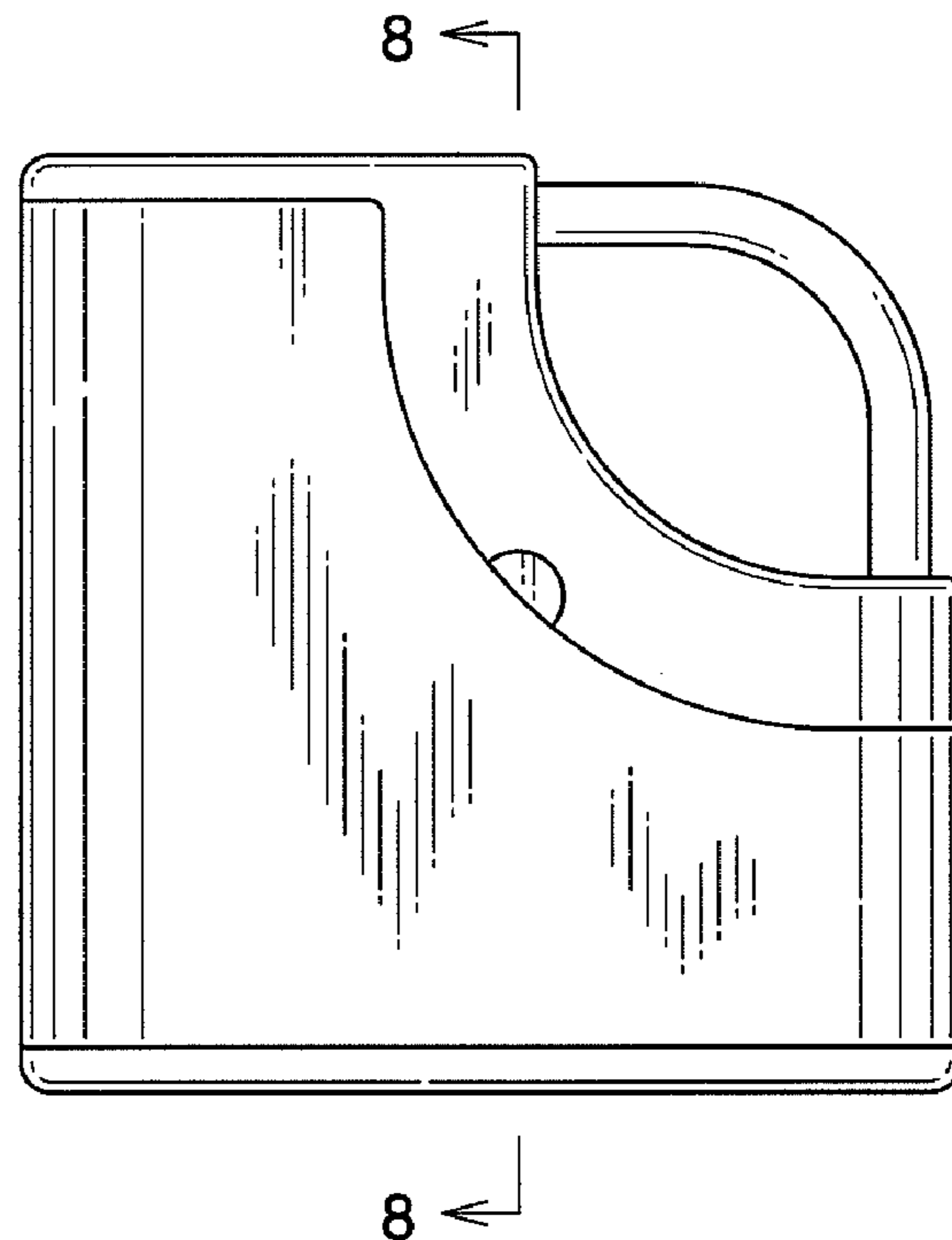
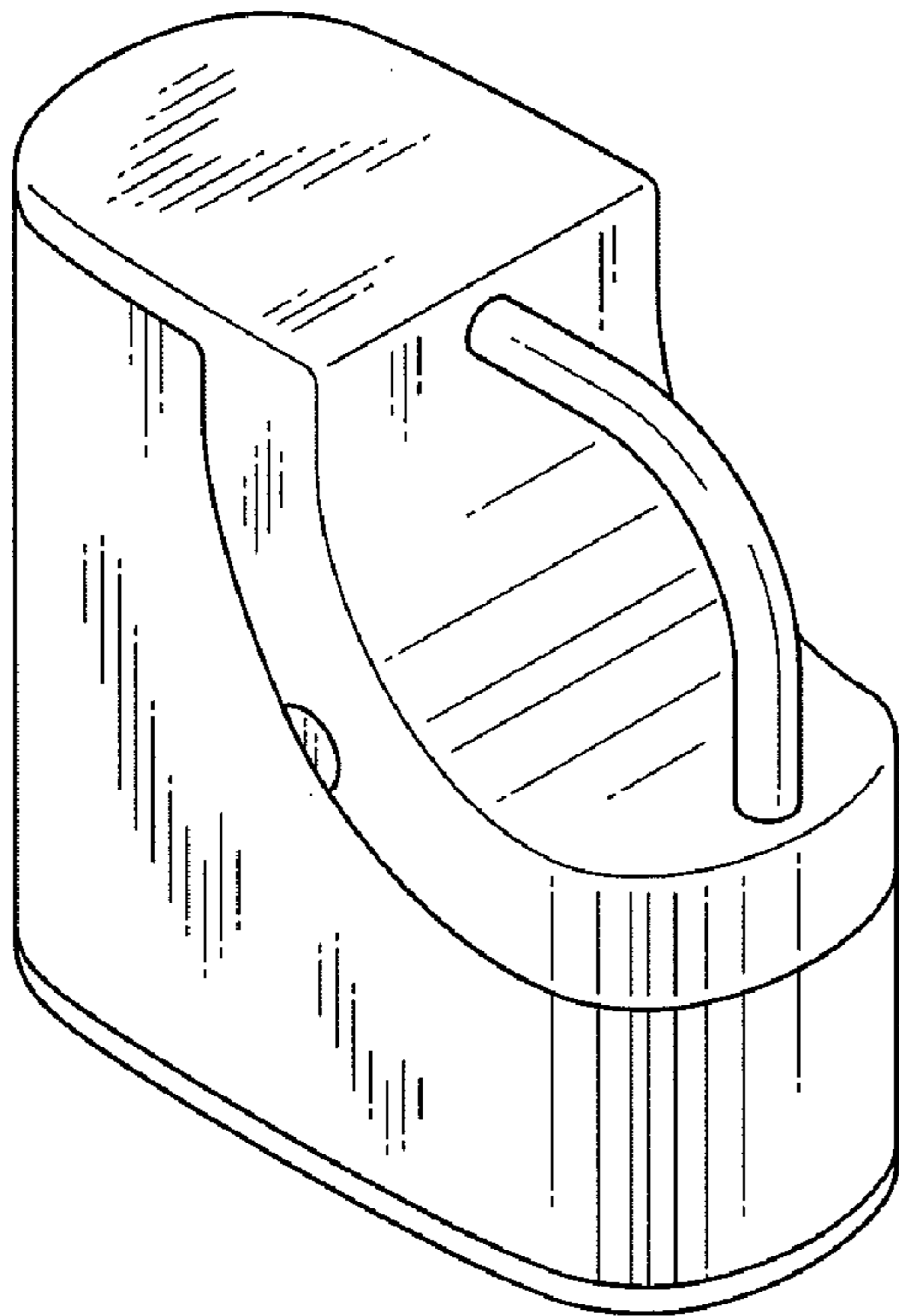

FIG.1

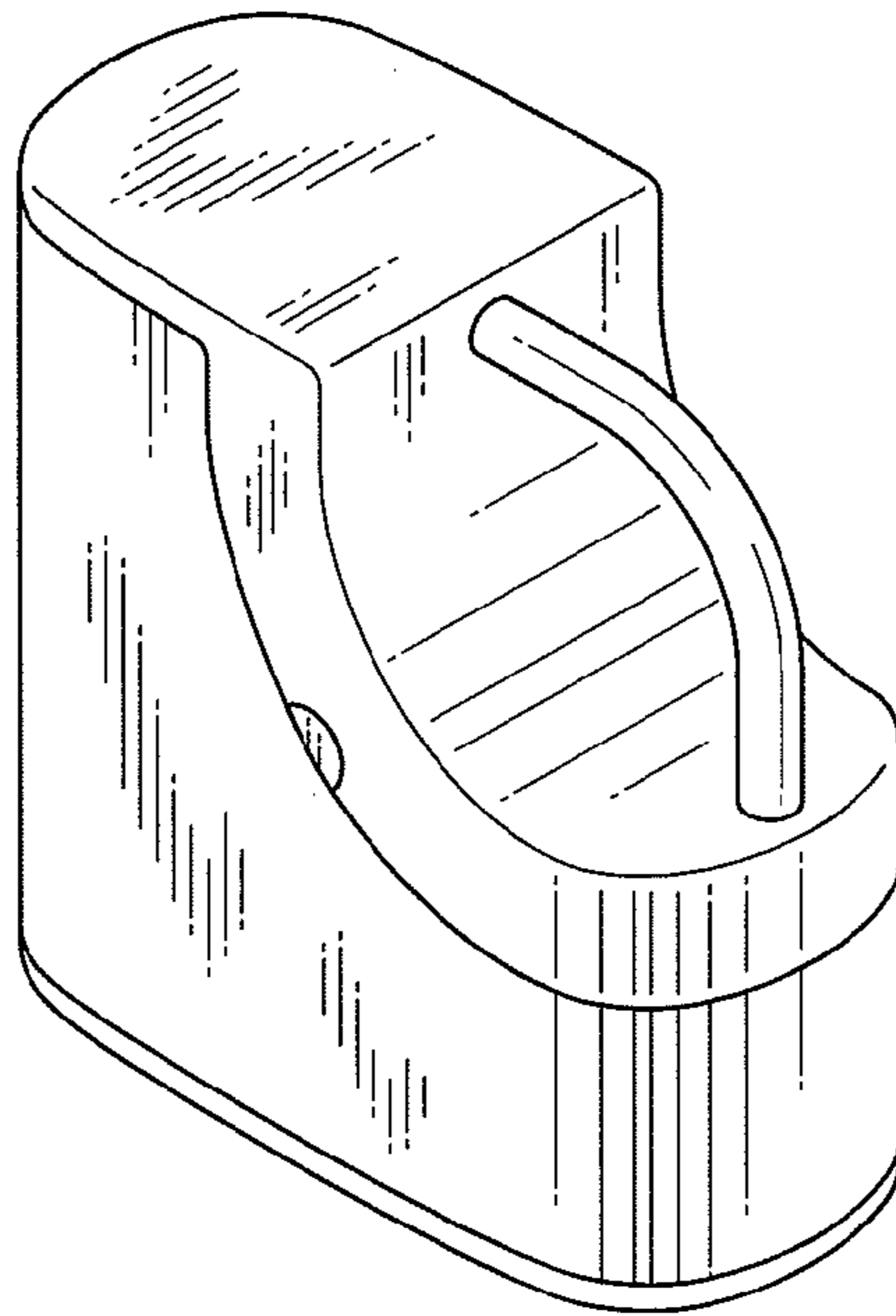
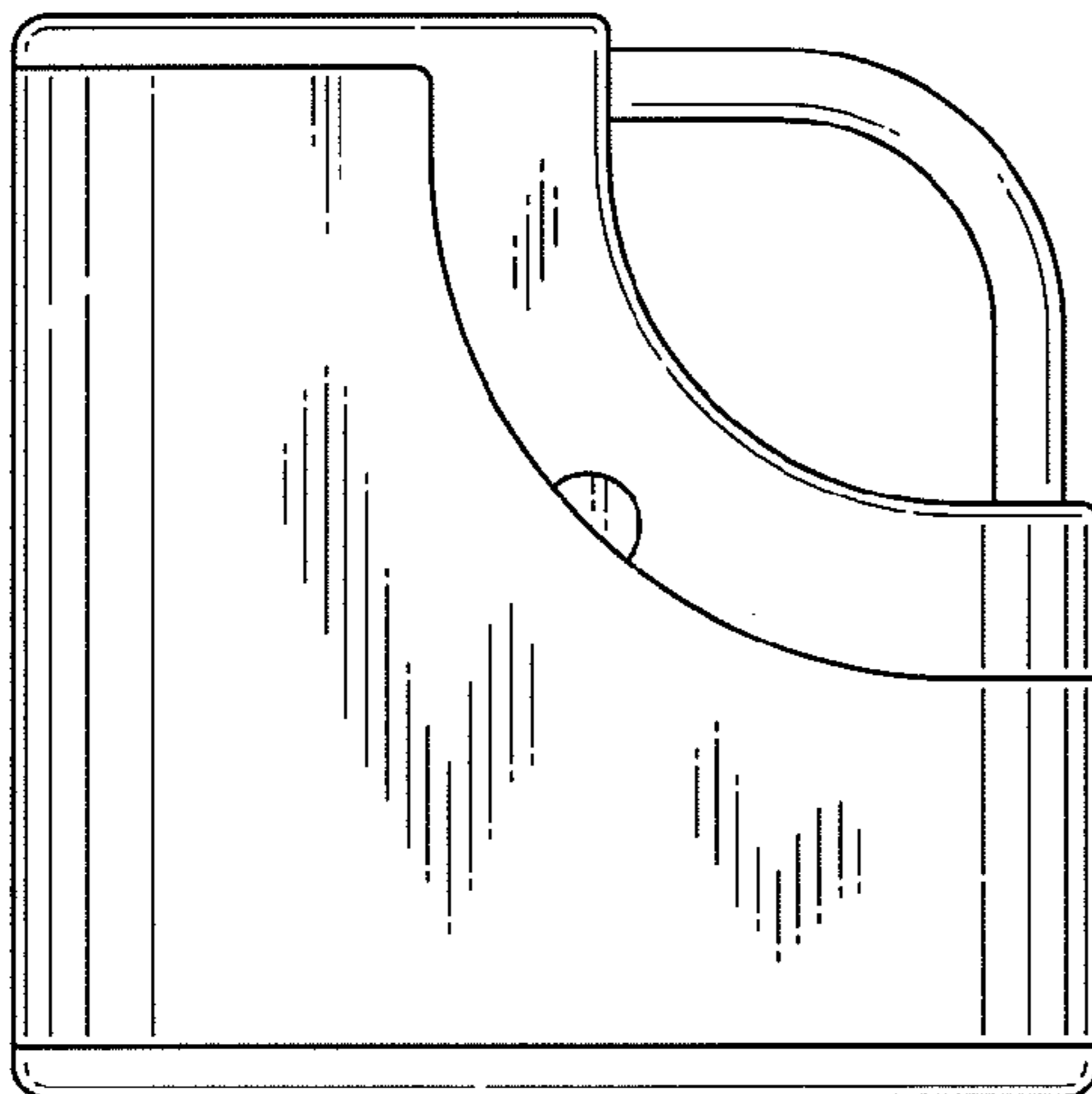

FIG.2

8 ←



8 ←

FIG.3

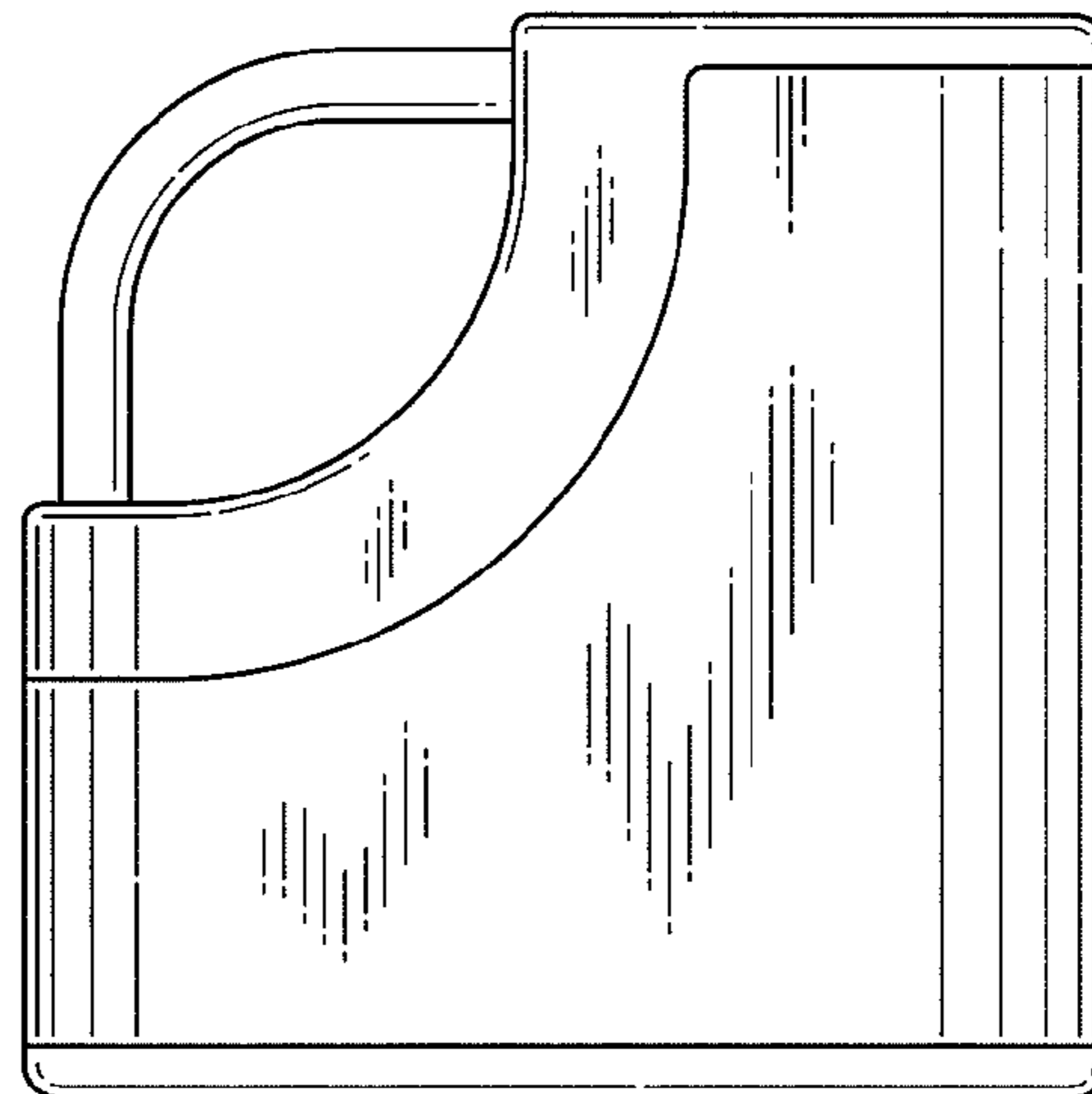

FIG.4

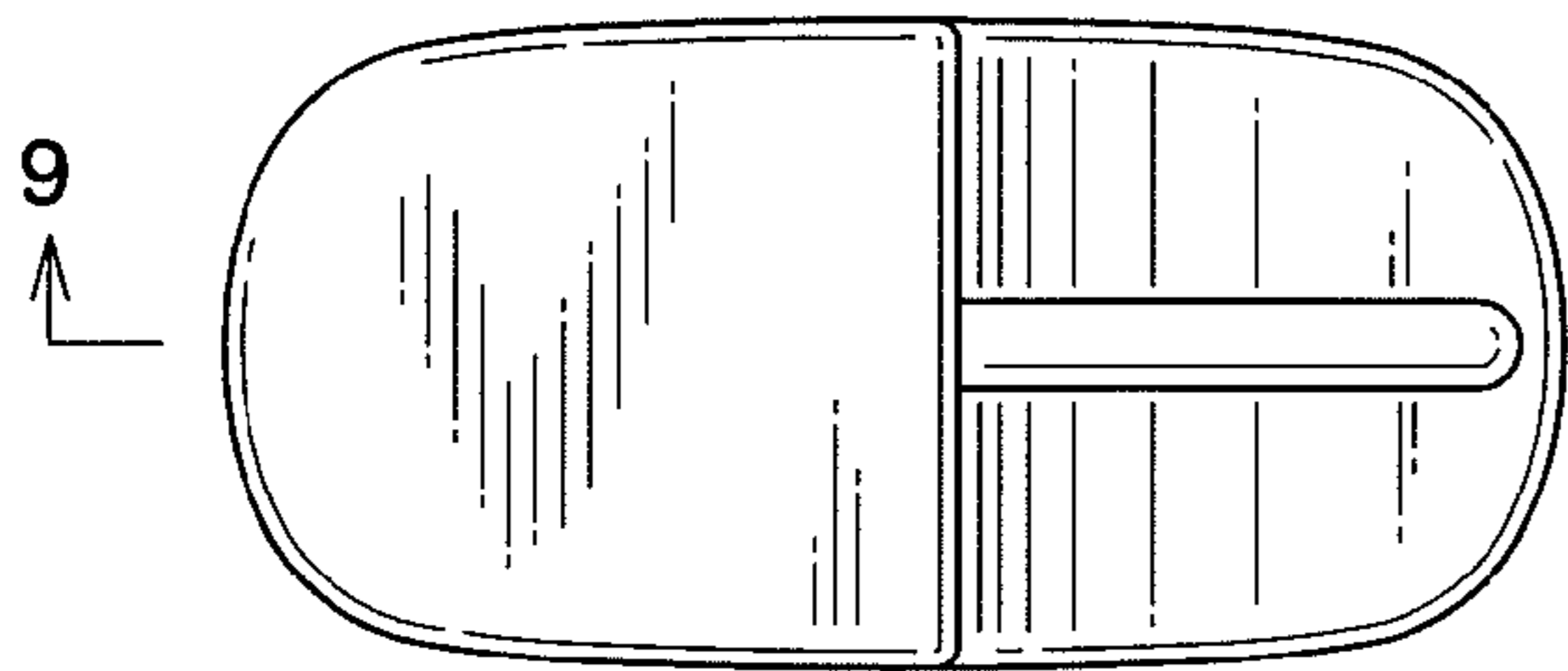

FIG.5

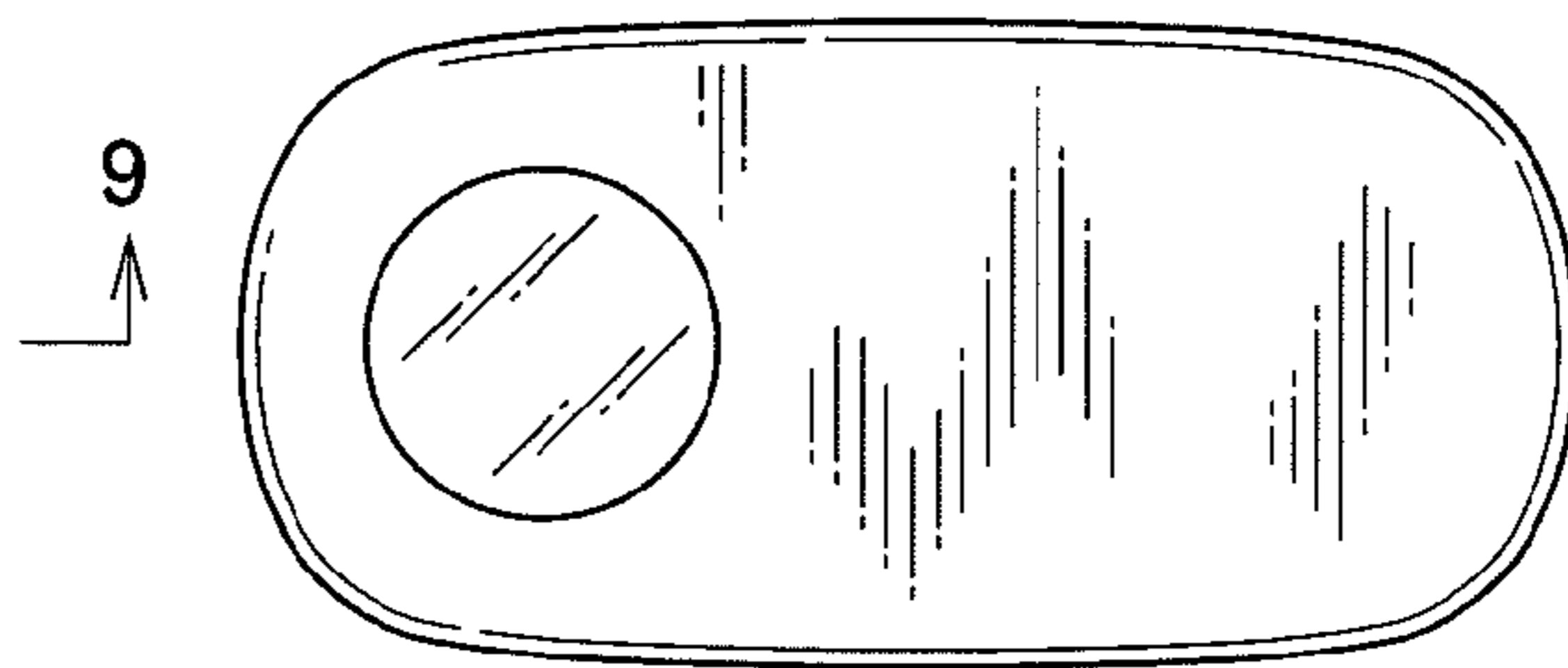

FIG.6

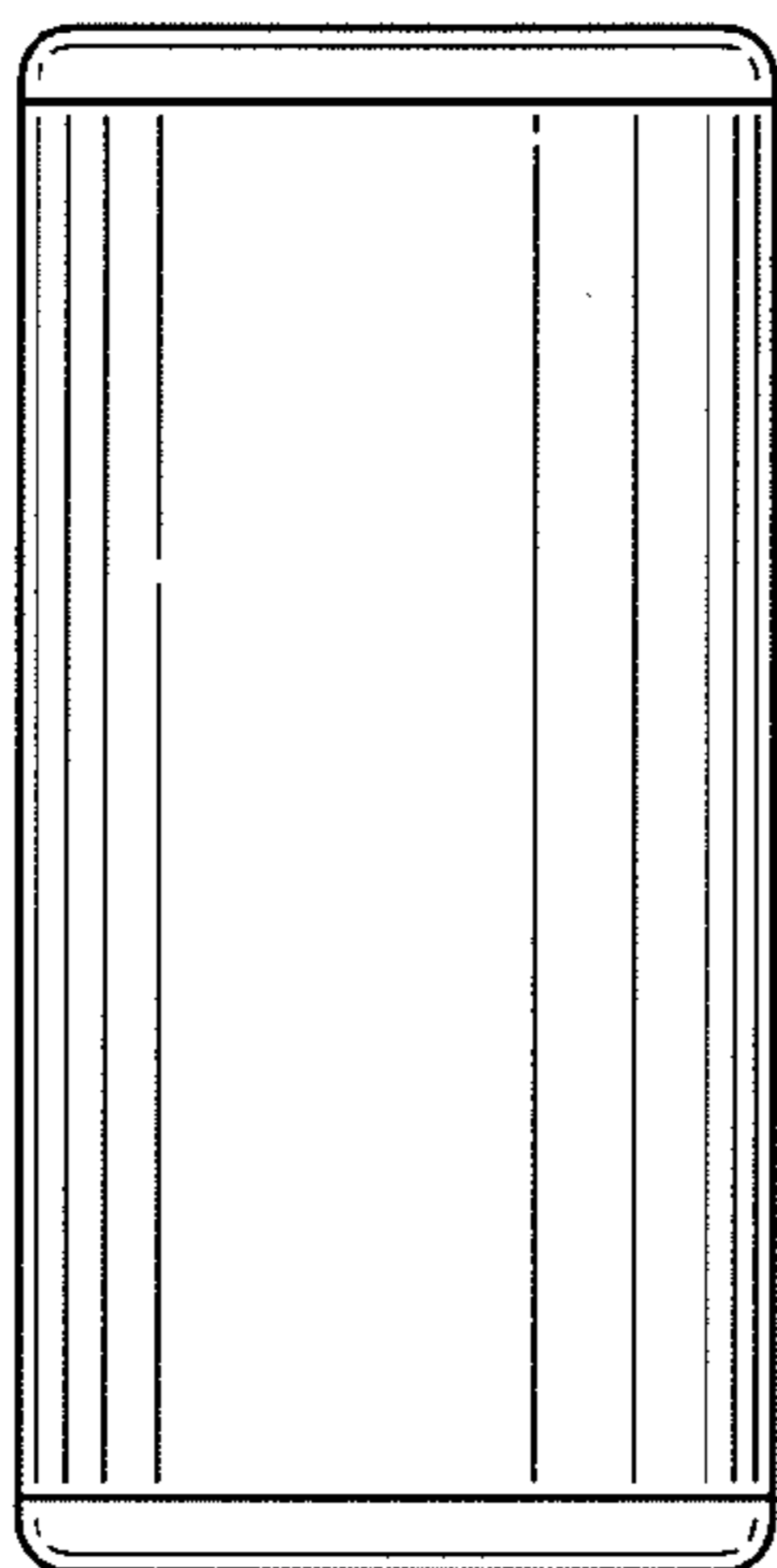

FIG.7

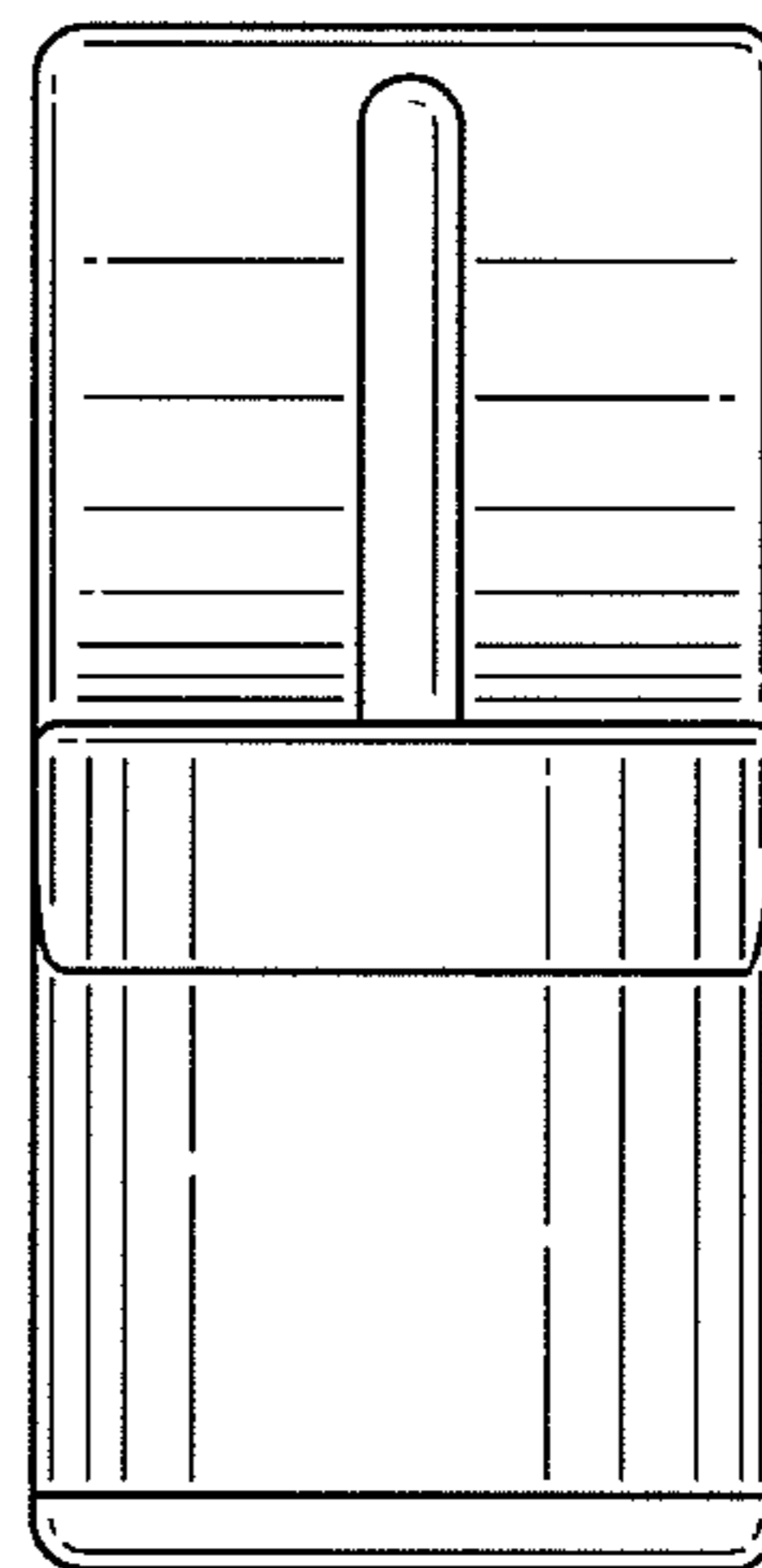

FIG.8

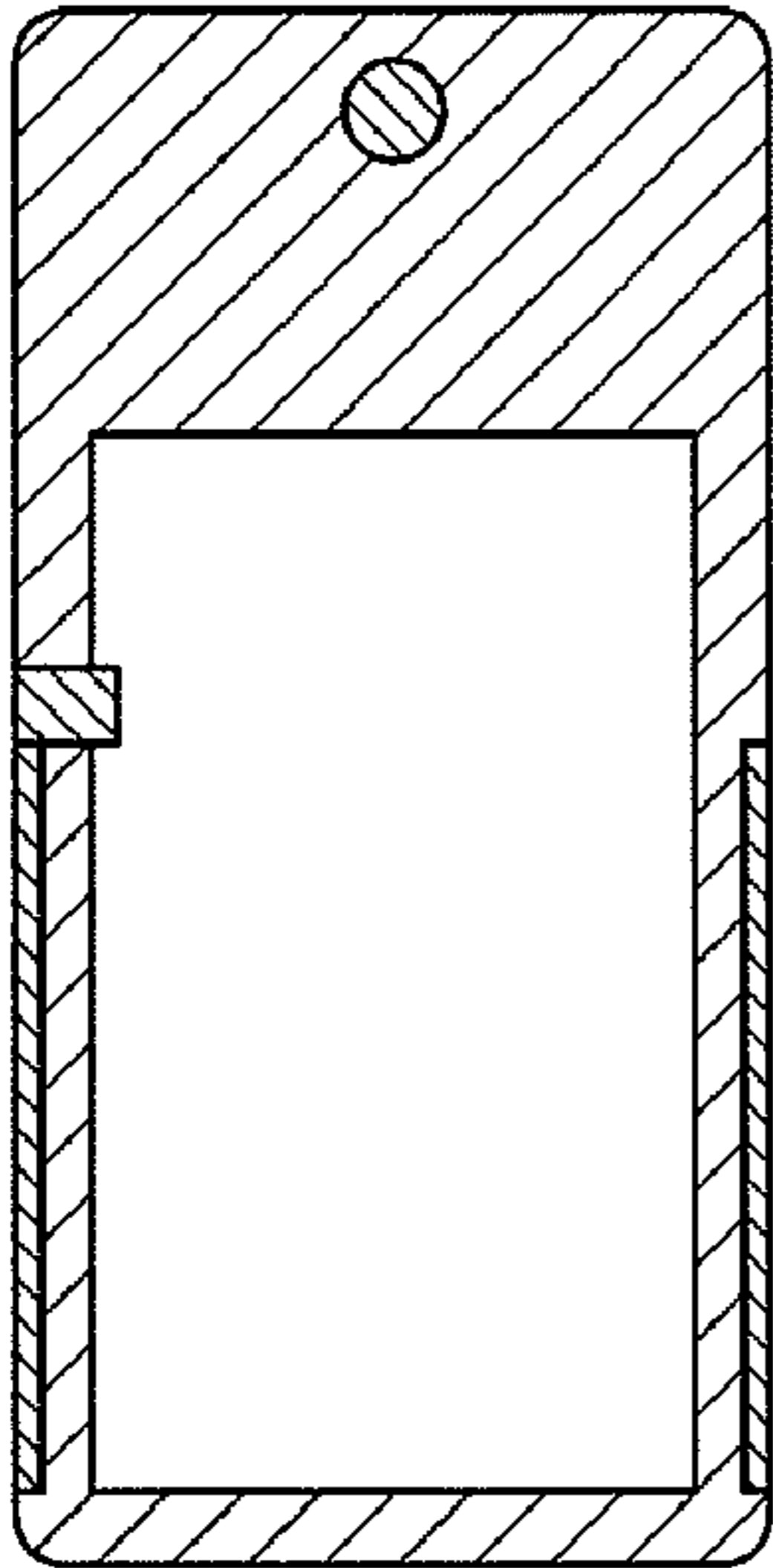

FIG.9

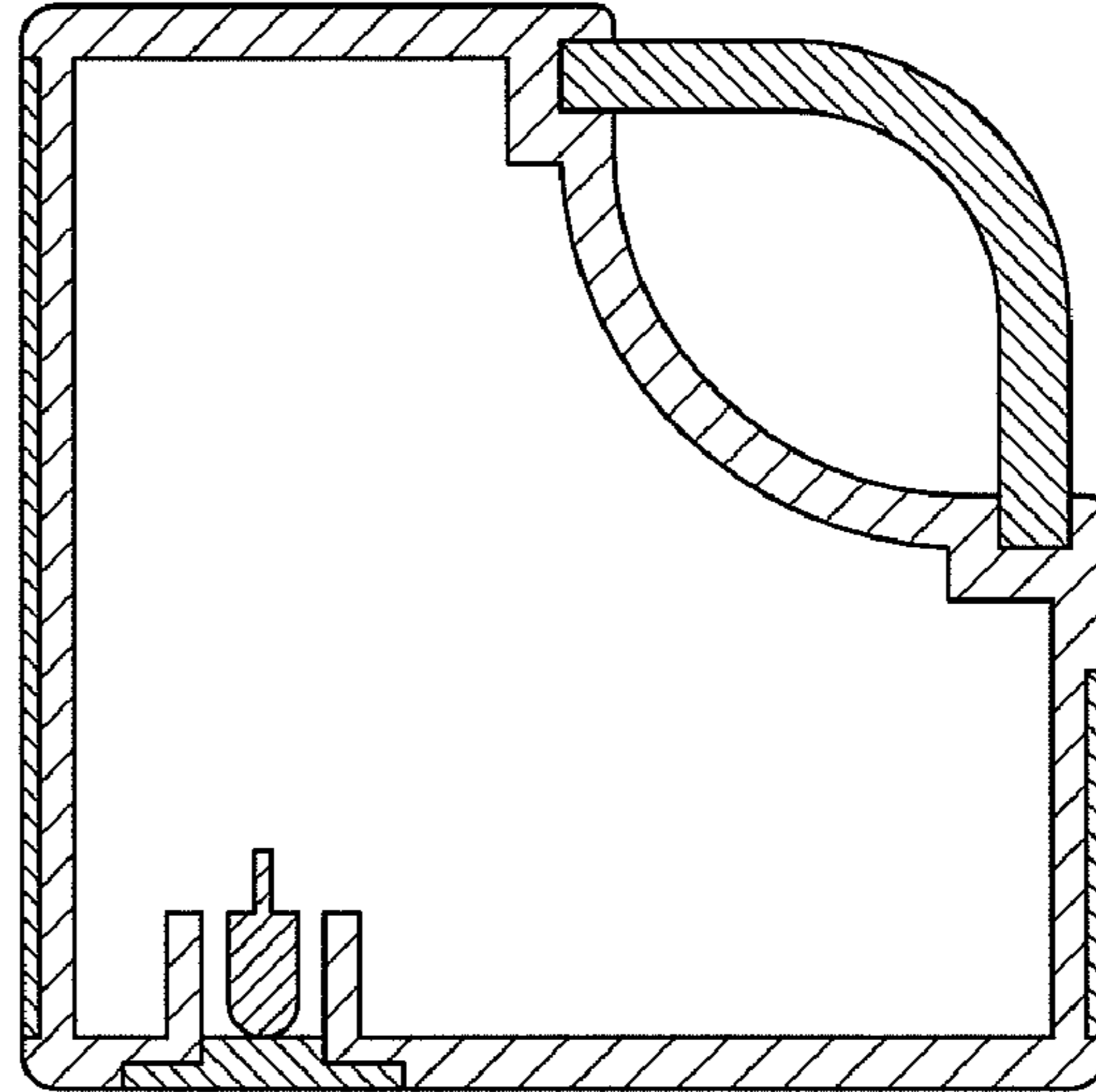

FIG.10

