

US00D597392S

(12) **United States Design Patent**  
**Meyers et al.**

(10) **Patent No.:** **US D597,392 S**

(45) **Date of Patent:** **\*\* Aug. 4, 2009**

(54) **DRIVER TOOL**

(75) Inventors: **David O. Meyers**, Kaysville, UT (US);  
**Leroy McCray**, Chicago, IL (US);  
**Daniel Aceves**, Bala California (MX);  
**Maria Morehead**, Mount Prospect, IL (US)

(73) Assignee: **Robert Bosch GmbH**, Stuttgart (DE)

(\*\*) Term: **14 Years**

(21) Appl. No.: **29/291,207**

(22) Filed: **Aug. 17, 2007**

(51) **LOC (9) Cl.** ..... **08-05**

(52) **U.S. Cl.** ..... **D8/68**

(58) **Field of Classification Search** ..... D8/14.1,  
D8/61, 62, 63, 64, 65, 66, 67, 68, 69, 70;  
81/57.11, 429, 454, 455, 456, 469, 489; 173/13,  
173/104, 114, 168, 169, 170, 171, 178, 201,  
173/211, 213, 217; 408/20, 124, 125, 234,  
408/241 R; 451/358; 310/50; 227/8, 113,  
227/114, 120, 130, 136, 142

See application file for complete search history.

(56) **References Cited**

**U.S. PATENT DOCUMENTS**

D382,457 S	*	8/1997	Ghode et al.	.....	D8/68
D436,819 S		1/2001	Liu		
D447,398 S	*	9/2001	Bazayev et al.	.....	D8/68
D459,178 S		6/2002	Heun		
D459,966 S		7/2002	So		
D486,713 S		2/2004	Lai		
D487,219 S	*	3/2004	Chudy et al.	.....	D8/68
D502,854 S	*	3/2005	Ng	.....	D8/68
D508,835 S		8/2005	Schiller et al.		
D509,119 S		9/2005	Schiller et al.		
D520,835 S	*	5/2006	Aglassinger	.....	D8/68
D524,625 S		7/2006	Wu		

D527,236 S		8/2006	Wu		
D531,000 S		10/2006	Meyers et al.		
D531,873 S		11/2006	Liu		
D532,666 S	*	11/2006	Chi	.....	D8/68
D532,667 S	*	11/2006	Tsai et al.	.....	D8/68
D534,048 S	*	12/2006	Tsai et al.	.....	D8/68
D550,052 S	*	9/2007	Lee	.....	D8/68

\* cited by examiner

*Primary Examiner*—T. Chase Nelson

*Assistant Examiner*—Karen Acker

(74) *Attorney, Agent, or Firm*—Maginot, Moore & Beck

(57) **CLAIM**

The ornamental design for a driver tool, as shown and described.

**DESCRIPTION**

FIG. 1 is a perspective view a driver tool showing our new design;

FIG. 2 is a left side elevational view showing the design for the driver tool of FIG. 1;

FIG. 3 is a right side elevational view showing the design for the driver tool of FIG. 1;

FIG. 4 is a top plan view showing the design for the driver tool of FIG. 1;

FIG. 5 is a bottom plan view showing the design for the driver tool of FIG. 1;

FIG. 6 is a front elevational view showing the design for the driver tool of FIG. 1; and,

FIG. 7 is a rear elevational view showing the design for the driver tool of FIG. 1.

The broken lines in the drawings depict portions of the driver tool that are not part of the claim. The broken lines and the structures and features they depict form no part of the claimed design.

**1 Claim, 6 Drawing Sheets**

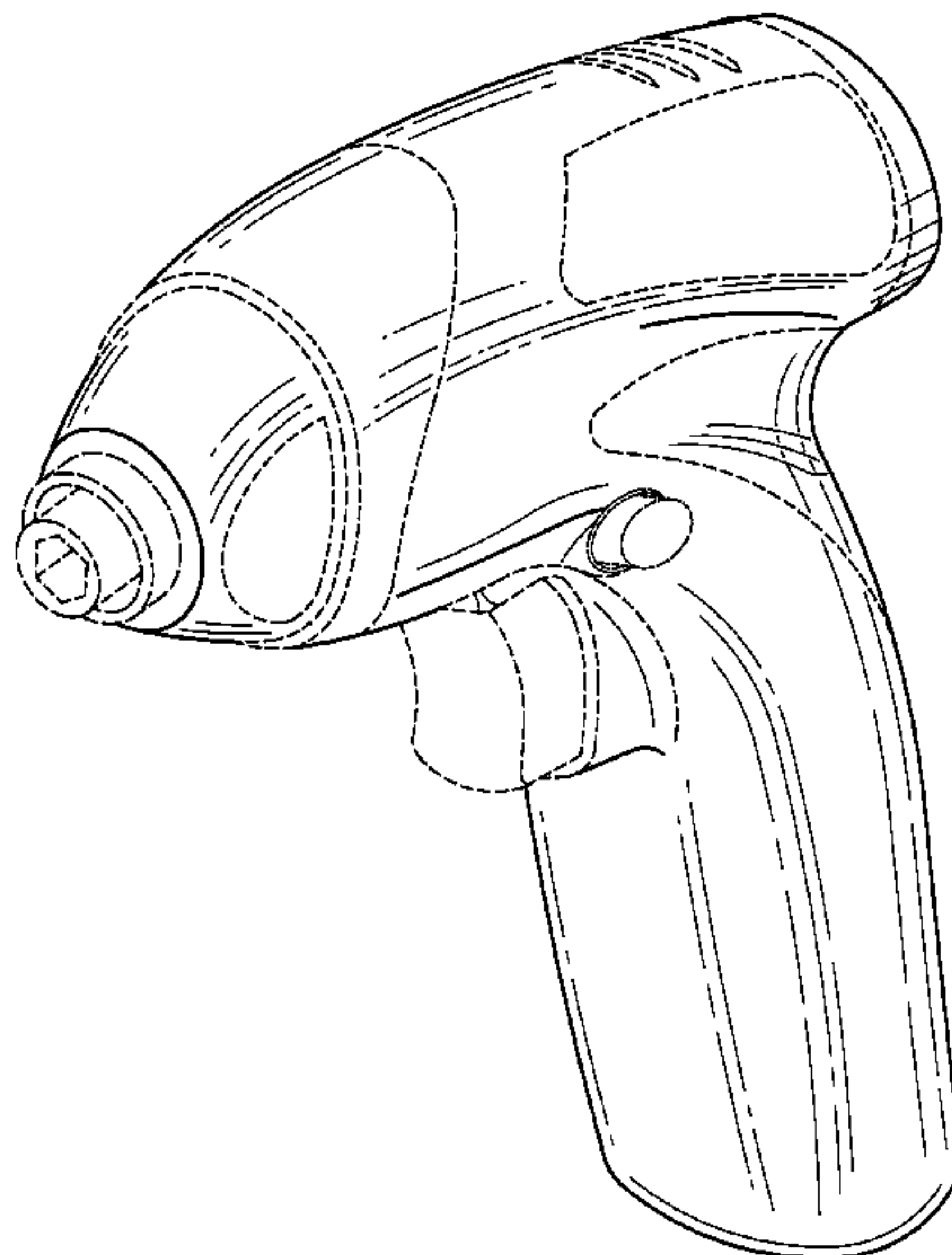

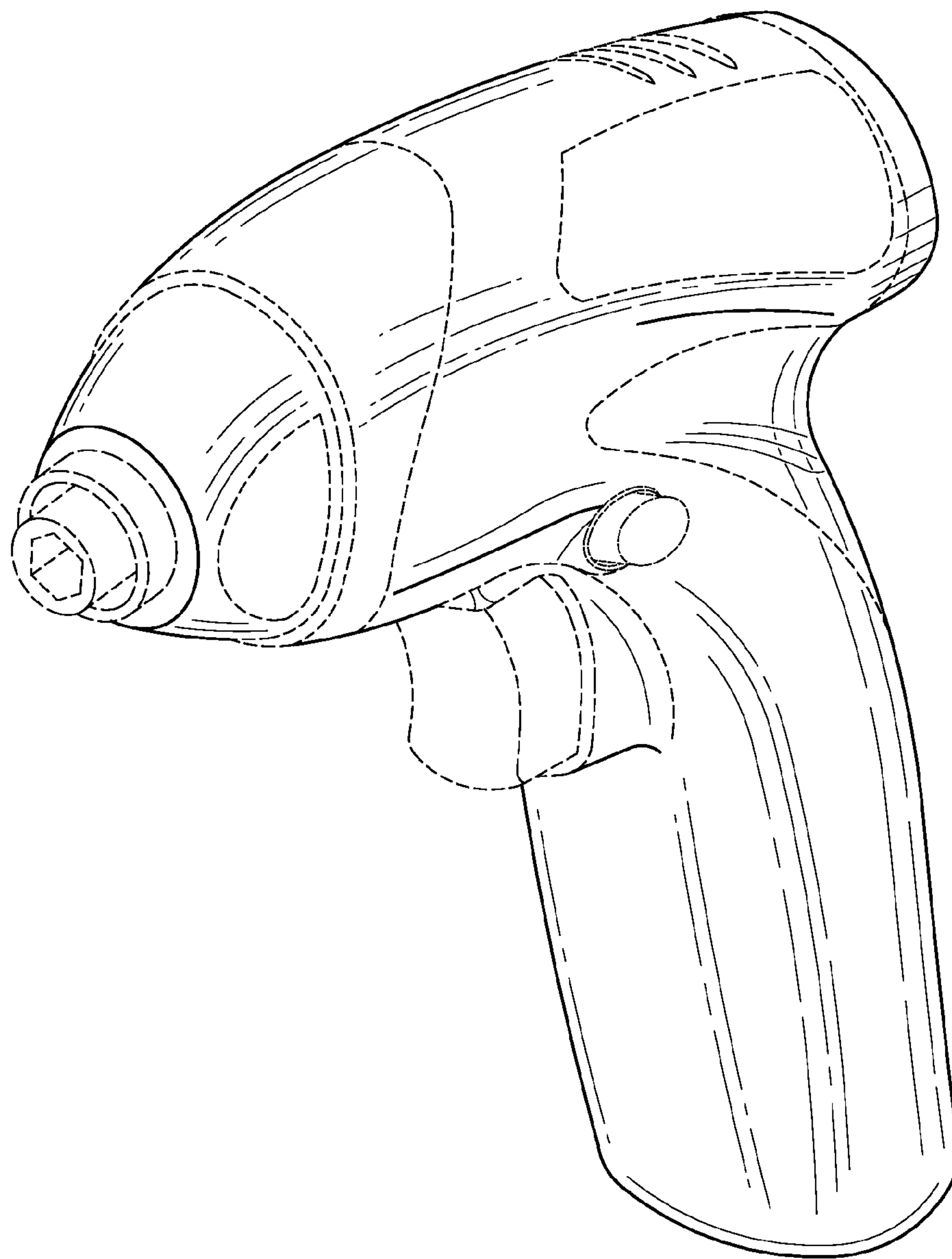

Fig. 1

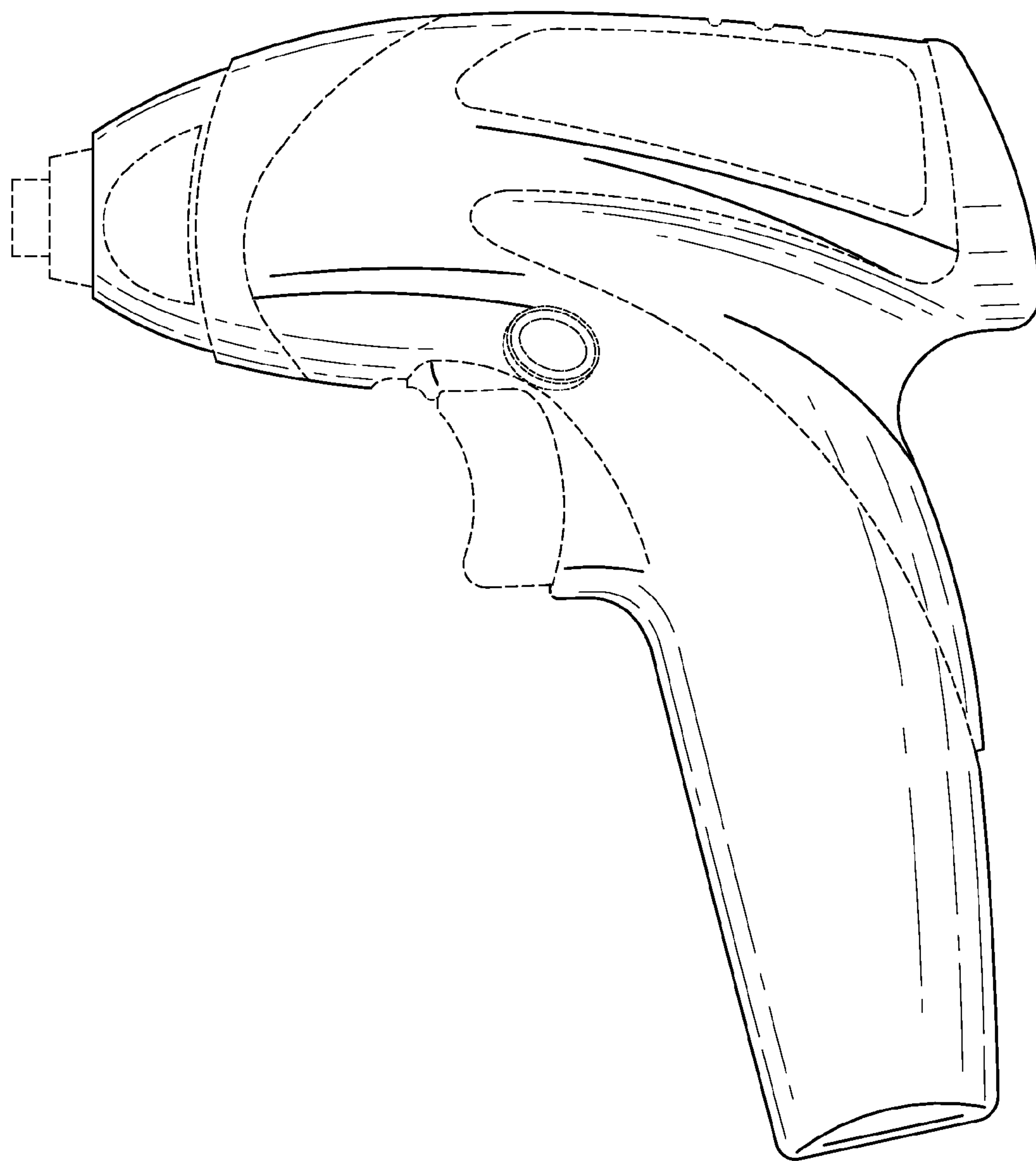

Fig. 2

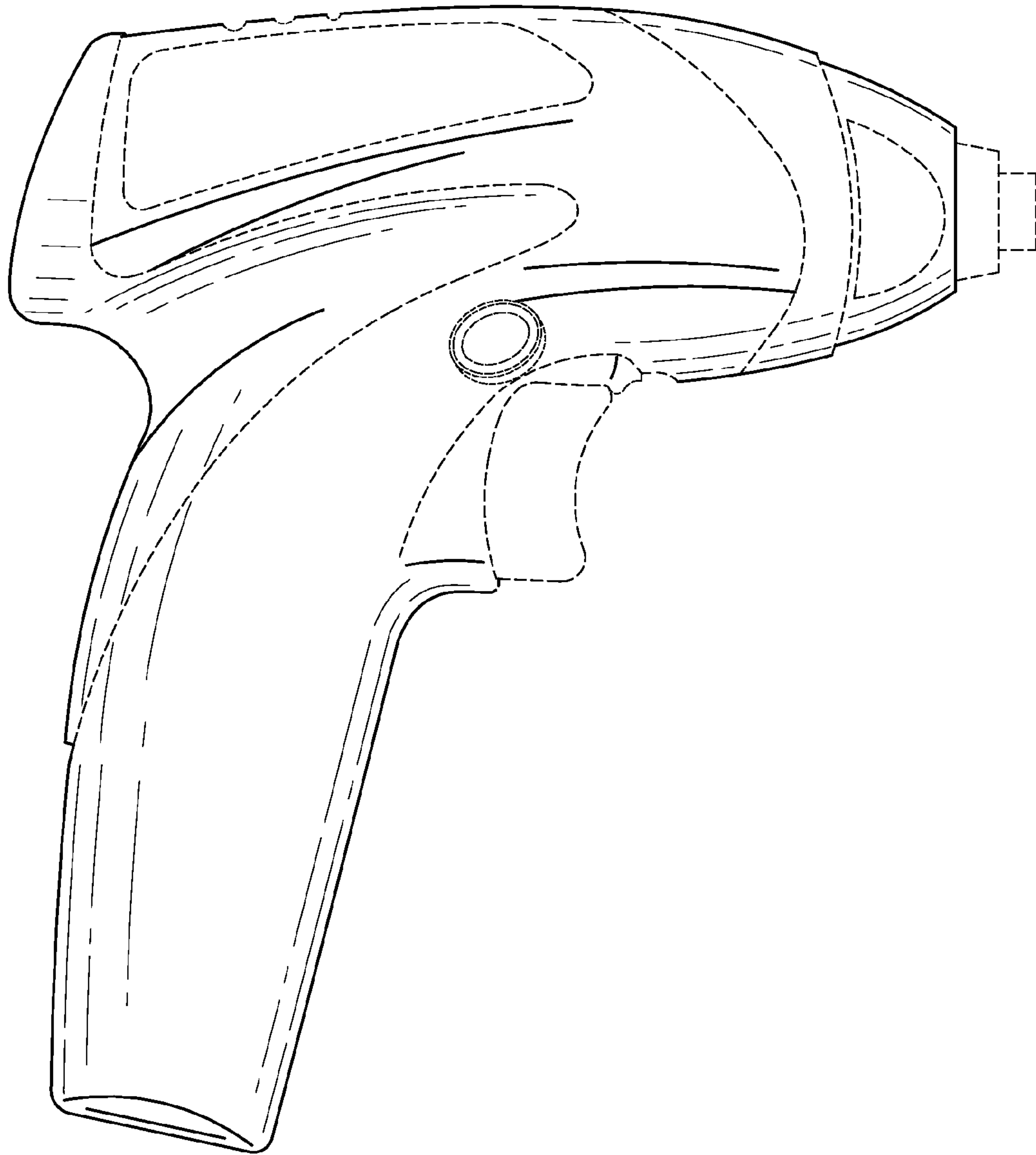

Fig. 3

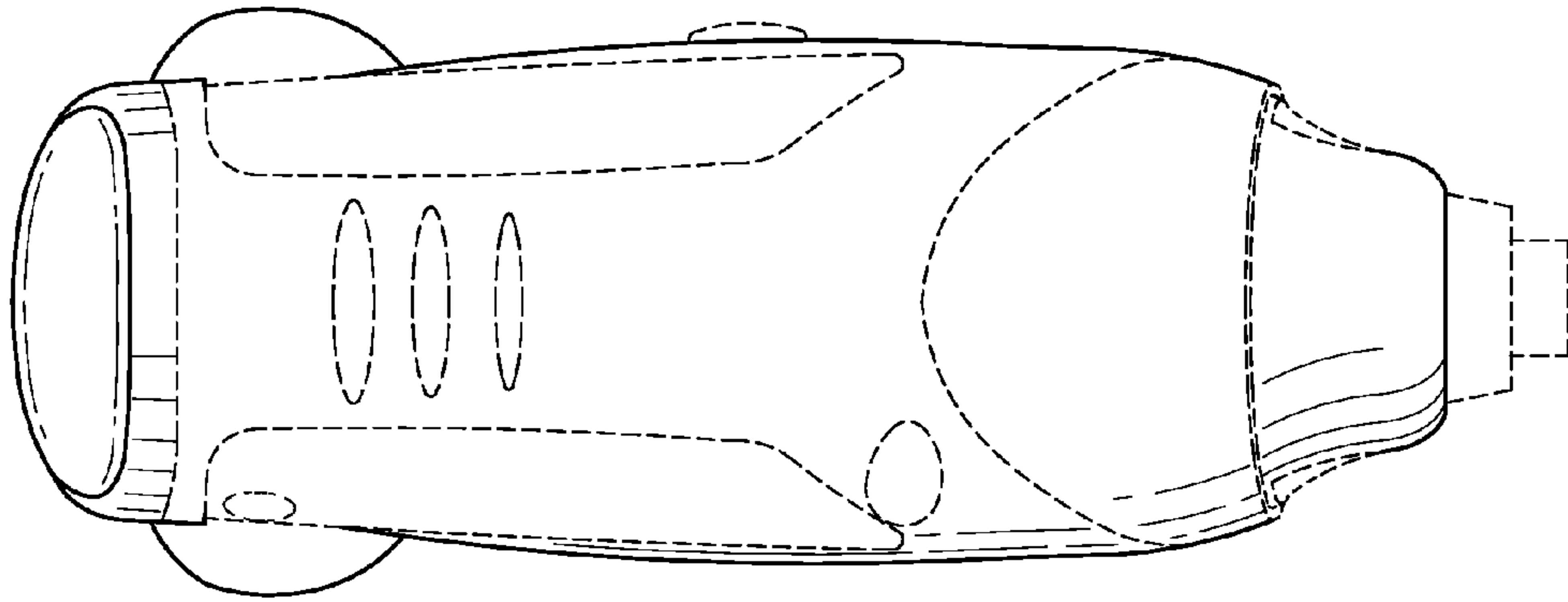

Fig. 4

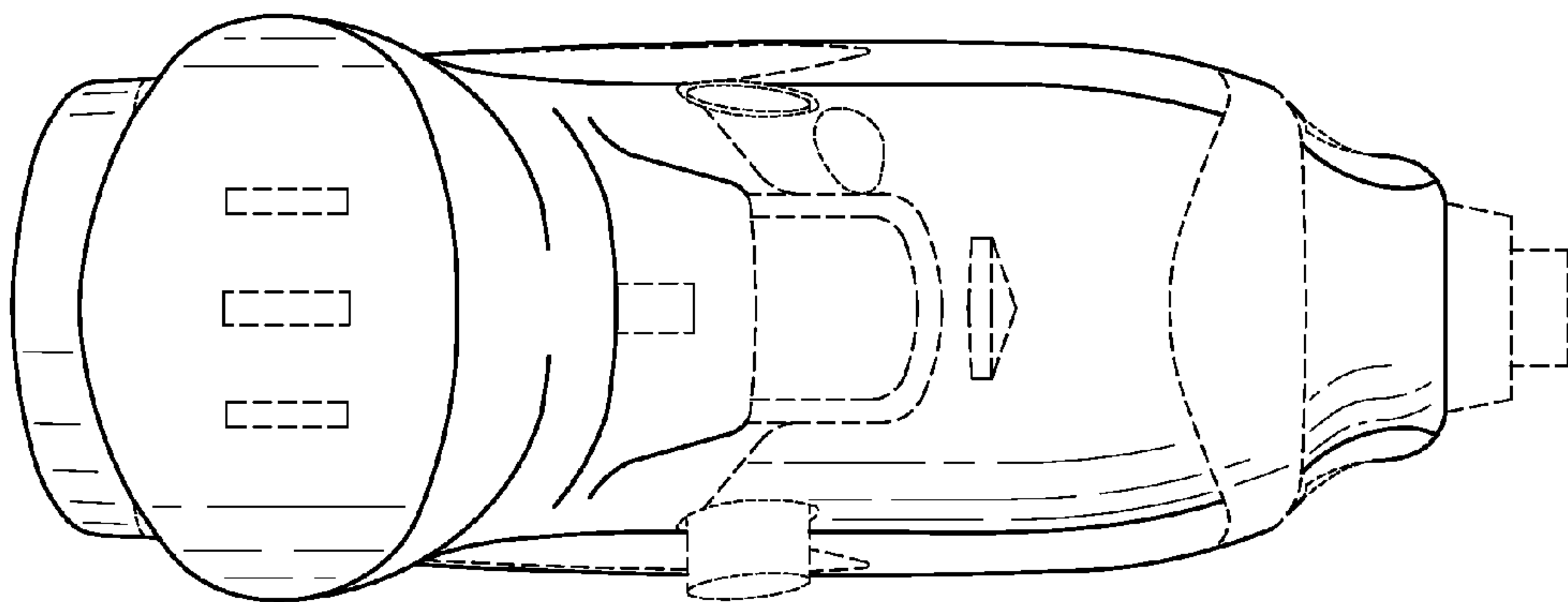

Fig. 5

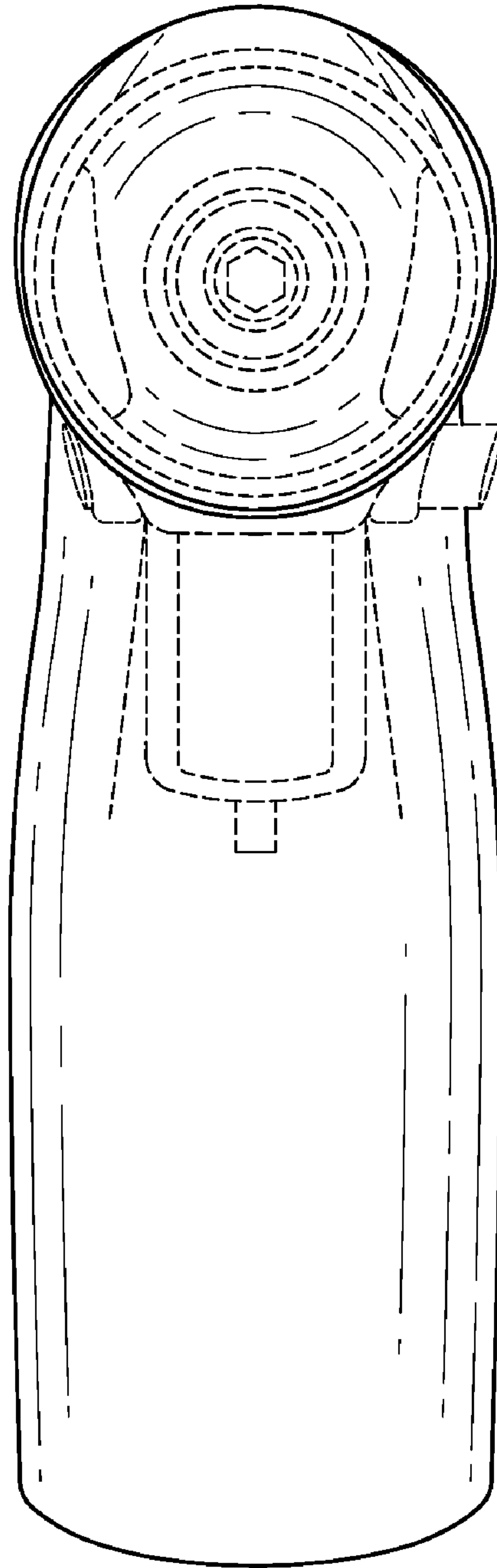

Fig. 6



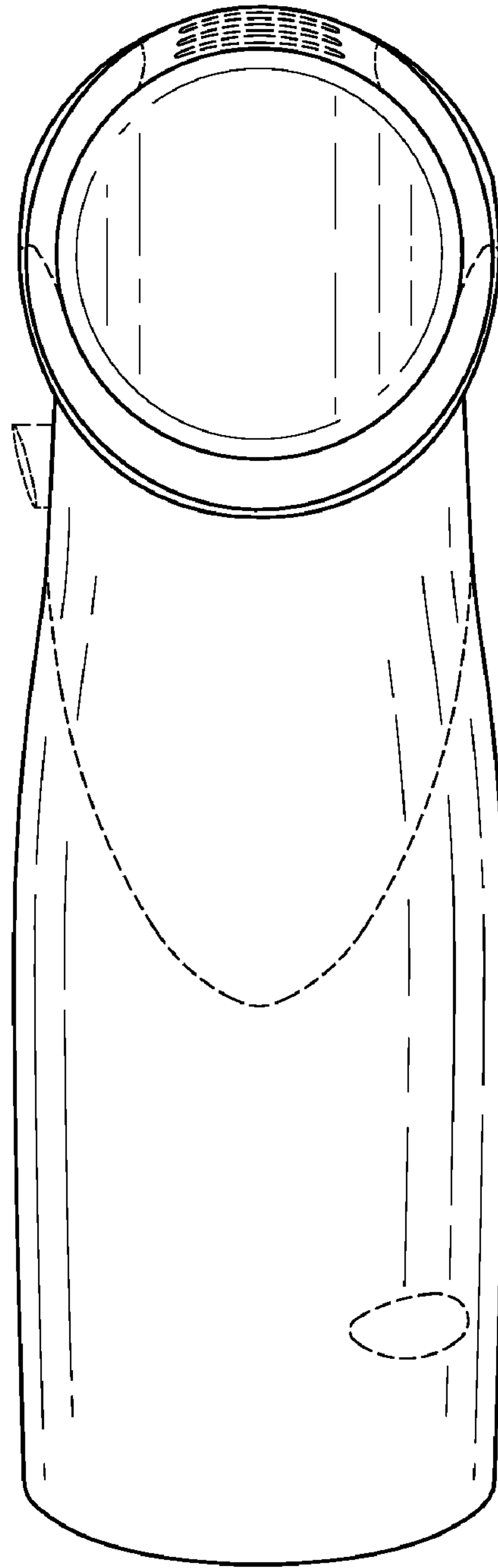

Fig. 7