



US00D597204S

(12) **United States Design Patent**  
**Oberlaender et al.**

(10) **Patent No.:** **US D597,204 S**  
(45) **Date of Patent:** **\*\* Jul. 28, 2009**

(54) **MEDICAL INSTRUMENT**

(75) Inventors: **Martin Oberlaender**, Eugen (DE);  
**Michael Sauer**, Tuttlingen (DE)

(73) Assignee: **Karl Storz GmbH & Co. KG** (DE)

(\*\*) Term: **14 Years**

(21) Appl. No.: **29/284,913**

(22) Filed: **Sep. 18, 2007**

(30) **Foreign Application Priority Data**

May 9, 2007 (EM) ..... 000720305

(51) **LOC (9) Cl.** ..... **24-02**

(52) **U.S. Cl.** ..... **D24/133; D24/140; D24/146;**  
**D24/147**

(58) **Field of Classification Search** ..... D24/130,  
D24/140, 133, 137-138, 143, 145-147, 19,  
D24/107-108, 129, 112, 144; D10/70-72;  
604/523, 263, 167.06; 285/41, 46, 49, 170,  
285/179-180, 172, 184, 128, 131-132, 135-136,  
285/138; 600/101, 104-105, 112-114, 119-123,  
600/153-154, 156-158, 162, 79  
See application file for complete search history.

(56) **References Cited**

**U.S. PATENT DOCUMENTS**

D287,631 S \* 1/1987 Anspach, Jr. .... D24/147  
4,776,847 A \* 10/1988 Krebs ..... 604/164.06  
D342,136 S \* 12/1993 Lafferty et al. .... D24/138

5,403,264 A \* 4/1995 Wohlers et al. .... 600/32  
D378,780 S \* 4/1997 Shuler ..... D24/146  
D379,854 S \* 6/1997 Hirsch et al. .... D24/112  
5,807,280 A \* 9/1998 Davis ..... 600/587  
5,843,031 A \* 12/1998 Hermann et al. .... 604/95.01  
6,159,182 A \* 12/2000 Davis et al. .... 604/167.06  
D440,659 S \* 4/2001 Ogino et al. .... D24/138  
6,322,494 B1 \* 11/2001 Bullivant et al. .... 600/104  
2008/0122148 A1 \* 5/2008 Frey et al. .... 269/1  
2008/0183201 A1 \* 7/2008 Berberich ..... 606/170  
2008/0234713 A1 \* 9/2008 Bernardini ..... 606/170

\* cited by examiner

*Primary Examiner*—Ian Simmons

*Assistant Examiner*—Wan Laymon

(74) *Attorney, Agent, or Firm*—St. Onge Steward Johnston &  
Reens LLC

(57) **CLAIM**

The ornamental design for a medical instrument, as shown  
and described.

**DESCRIPTION**

FIG. 1 is a front view of a medical instrument in accordance  
with the new design;

FIG. 2 is a rear view thereof;

FIG. 3 is a left side view thereof;

FIG. 4 is a right side view thereof;

FIG. 5 is a top view thereof; and,

FIG. 6 is a bottom view thereof.

**1 Claim, 6 Drawing Sheets**

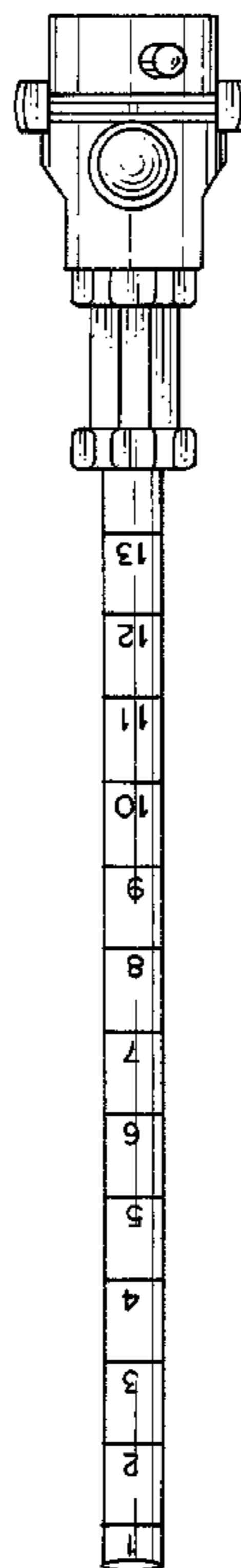

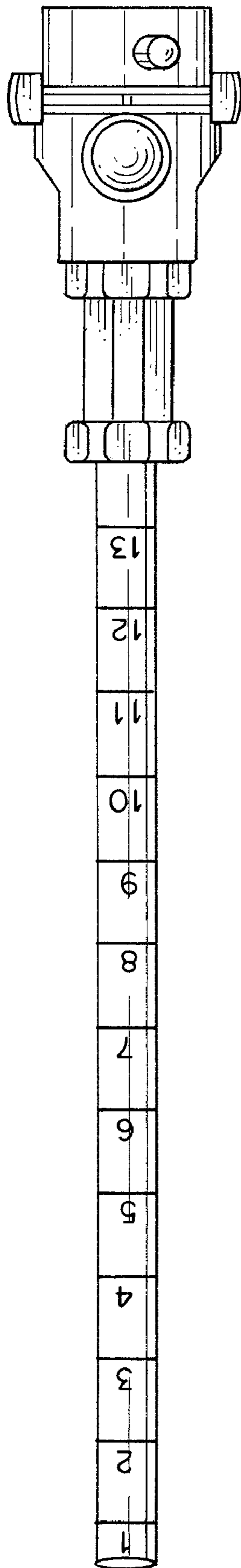

*FIG. 1*

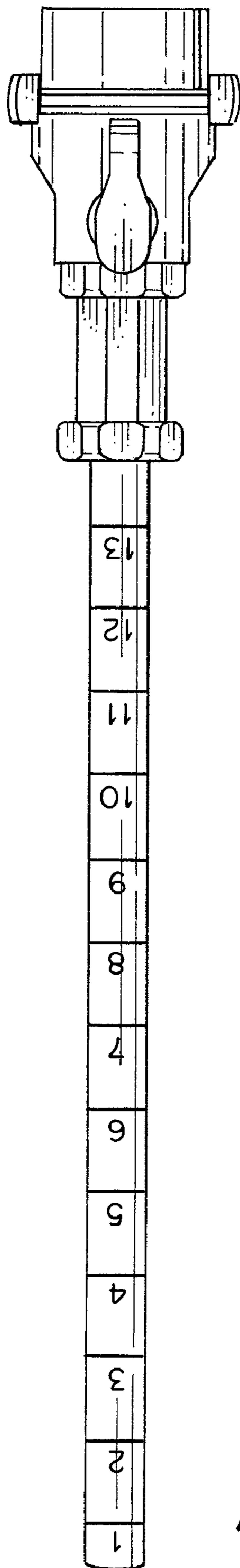
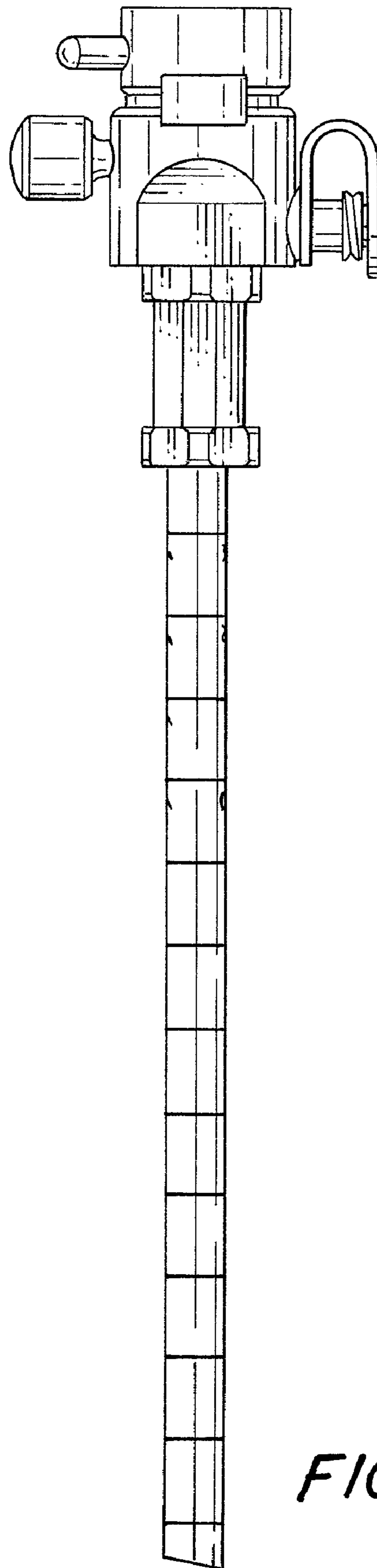
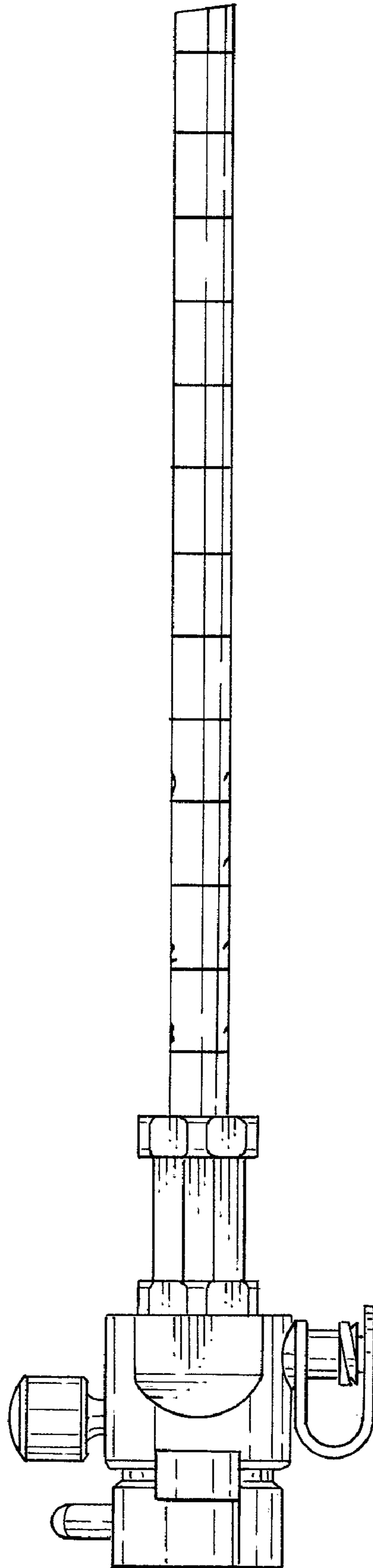

FIG. 2



*FIG. 3*



*FIG. 4*

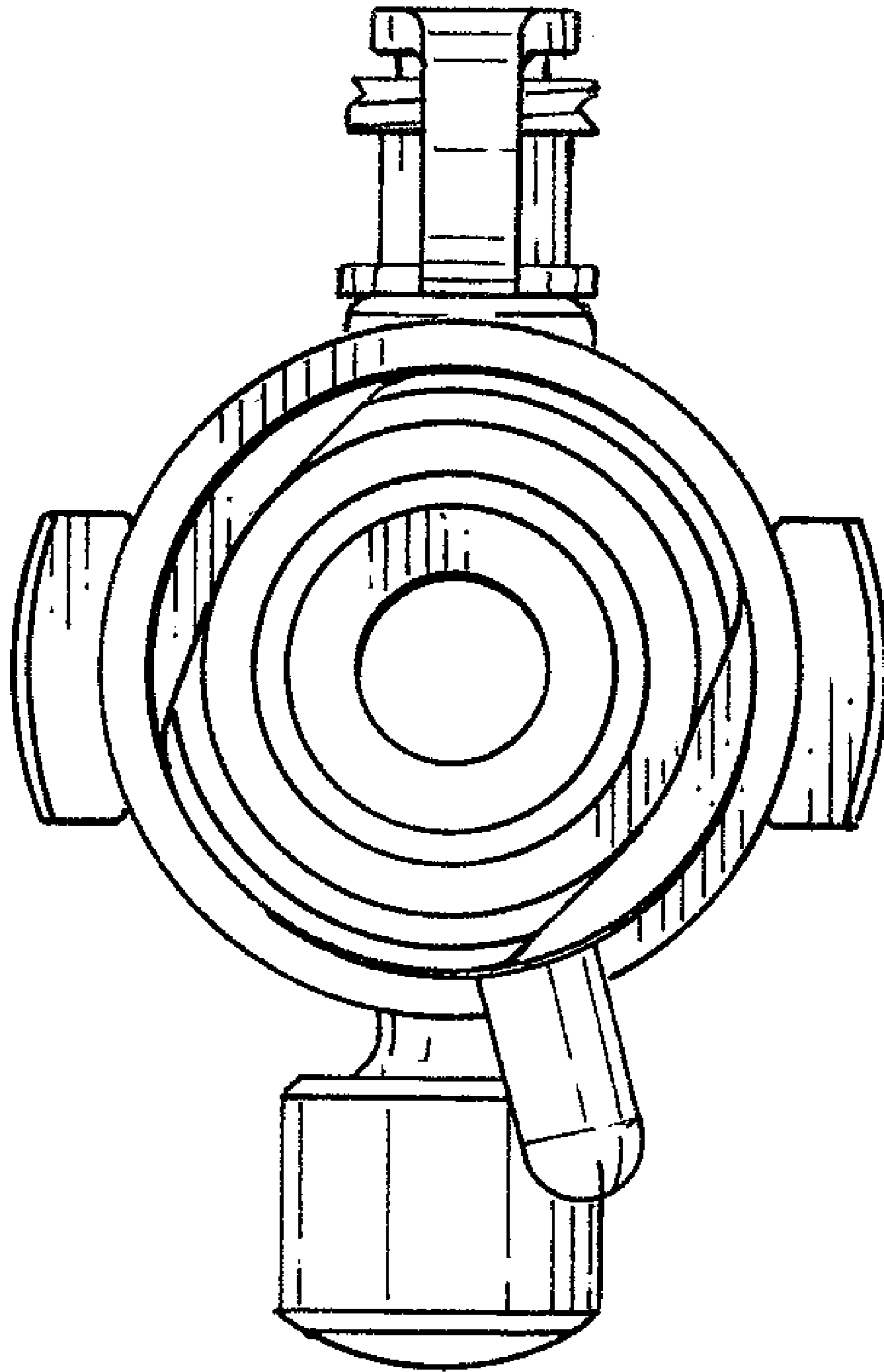

*FIG. 5*

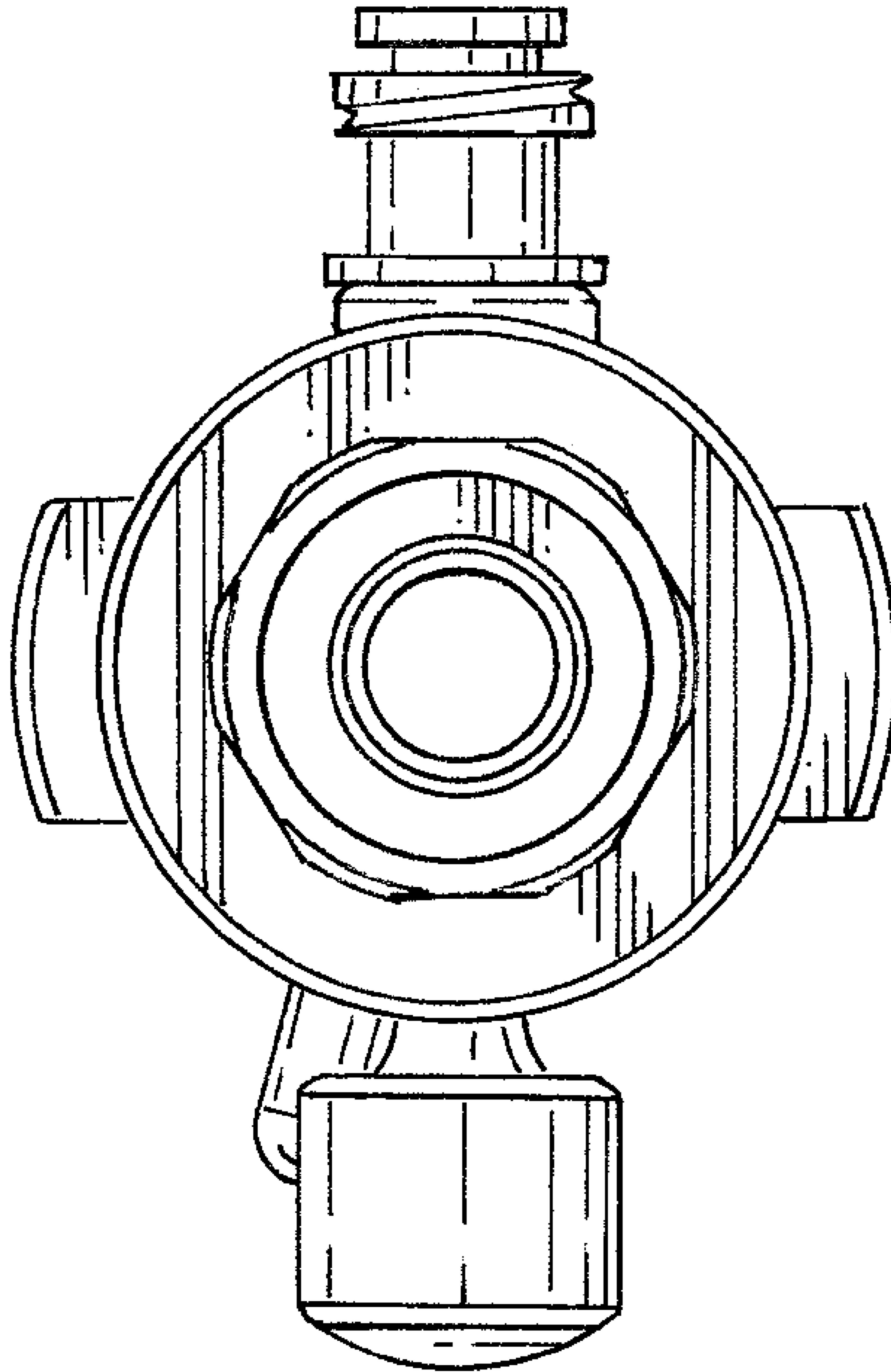

**FIG. 6**