

US00D597002S

(12) **United States Design Patent**
Jamieson et al.

(10) **Patent No.:** **US D597,002 S**
(45) **Date of Patent:** **** Jul. 28, 2009**

(54) **VEHICLE HOOD**

(75) Inventors: **Stuart Jamieson**, Chelsea, MI (US);
Freeman Thomas, Laguna Beach, CA
(US); **David Woodhouse**, Newport
Coast, CA (US)

(73) Assignee: **Ford Motor Company**, Dearborn, MI
(US)

(**) Term: **14 Years**

(21) Appl. No.: **29/302,104**

(22) Filed: **Jan. 10, 2008**

(51) **LOC (9) Cl.** **12-16**

(52) **U.S. Cl.** **D12/173**

(58) **Field of Classification Search** D12/90-92,
D12/173, 196, 86, 181, 400; 180/69.21,
180/69.2, 69.22; 296/24.4; D21/548
See application file for complete search history.

(56) **References Cited**

U.S. PATENT DOCUMENTS

D231,519 S *	4/1974	Darling	D12/173
D237,960 S *	12/1975	Whitehead	D12/173
D437,270 S *	2/2001	Yokomaku	D12/173
D445,384 S *	7/2001	Tirey et al.	D12/173
D487,239 S *	3/2004	Chan	D12/173
D524,705 S *	7/2006	Bettino	D12/181
D529,419 S	10/2006	Richards et al.		
D533,606 S *	12/2006	Kaminski	D21/548
D548,152 S *	8/2007	Chiang	D12/173
D559,742 S	1/2008	Thomas et al.		
D561,646 S *	2/2008	Thomas et al.	D12/92
D561,658 S	2/2008	Thomas et al.		
D561,665 S *	2/2008	Thomas et al.	D12/173
D563,277 S	3/2008	Thomas et al.		
D570,252 S *	6/2008	Peters et al.	D12/92
D571,258 S *	6/2008	Baum	D12/92
D571,267 S *	6/2008	Baum	D12/173
D584,996 S *	1/2009	Jamieson et al.	D12/91

OTHER PUBLICATIONS

Roth, Dan; "Detroit Auto Show: Ford Airstream Concept"; Autoblog website article, located at www.autoblog.com/2007/01/07/detroit-auto-show-ford-airstream-concept/; 16 pages; Jan. 7, 2007.

Thomas, David; "2006 L.A. Auto Show: Ford Explorer Fuel Cell"; Cars.com Kicking Tires article, located at http://blogs.cars.com/kickingtires/2006/11/2006_la_auto_sh_4.html; 33 pages; Nov. 28, 2006.

"Ford F-250 Super Chief Concept: A Bold, American Flex Fuel Pickup That Delivers Tomorrow's Fuel Today"; Ford Motor Company Press Release, located at http://media.ford.com/newsroom/release_display.cfm?release=22295; 5 pages; Jan. 8, 2006.

Pund, Daniel; "The Bold and the Brutiful: Ford designs another rear-drive sport sedan concept," Edmunds website article, located at <http://www.edmunds.com/insideline/do/Features/articleId=118988>; 2 pages; Dec. 30, 2006.

"2008 Explorer Maintains Leadership Among Midsize SUVs With Unmatched Features And Equipment"; Ford press release posted on Zer Customs website, located at <http://www.zercustoms.com/news/2008-ford-explorer.html>; 3 pages; Jul. 11, 2007.

* cited by examiner

Primary Examiner—Robert M Spear

Assistant Examiner—Cynthia Underwood

(74) *Attorney, Agent, or Firm*—Frank A. MacKenzie; Brooks Kushman P.C.

(57) **CLAIM**

The ornamental design for a vehicle hood, as shown and described.

DESCRIPTION

FIG. 1 is a front perspective view of a vehicle hood in accordance with the embodiment of the present invention;

FIG. 2 is a front/right side view of the vehicle hood of FIG. 1;

FIG. 3 is a right, front perspective view of the vehicle hood of FIG. 1;

FIG. 4 is a right side view of the vehicle hood of FIG. 1, wherein a left side view is a mirror image thereof; and,

FIG. 5 is a top plan view of the vehicle hood of FIG. 1.

The portions shown in broken lines are included to show environment and form no part of the claimed invention.

1 Claim, 5 Drawing Sheets

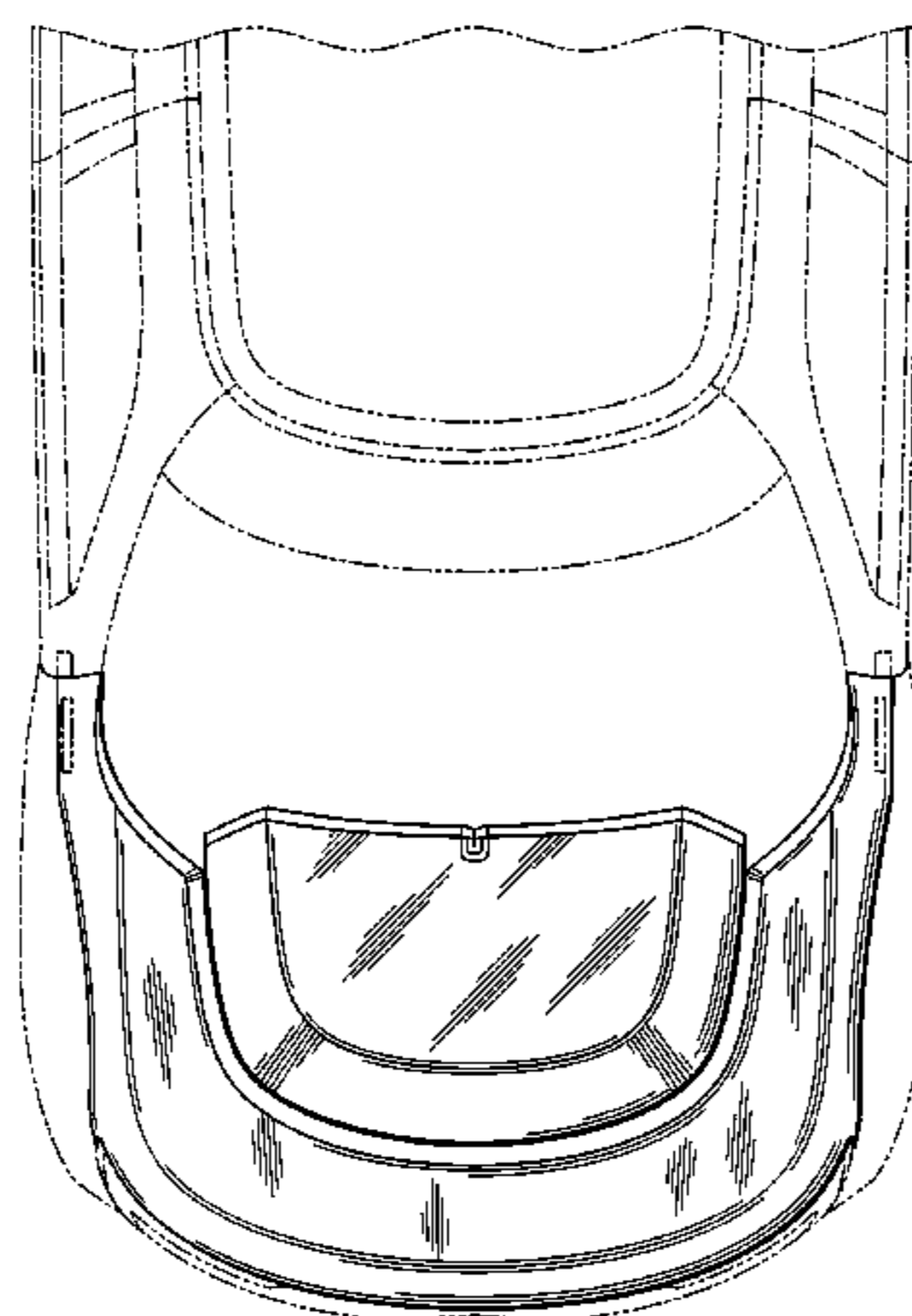

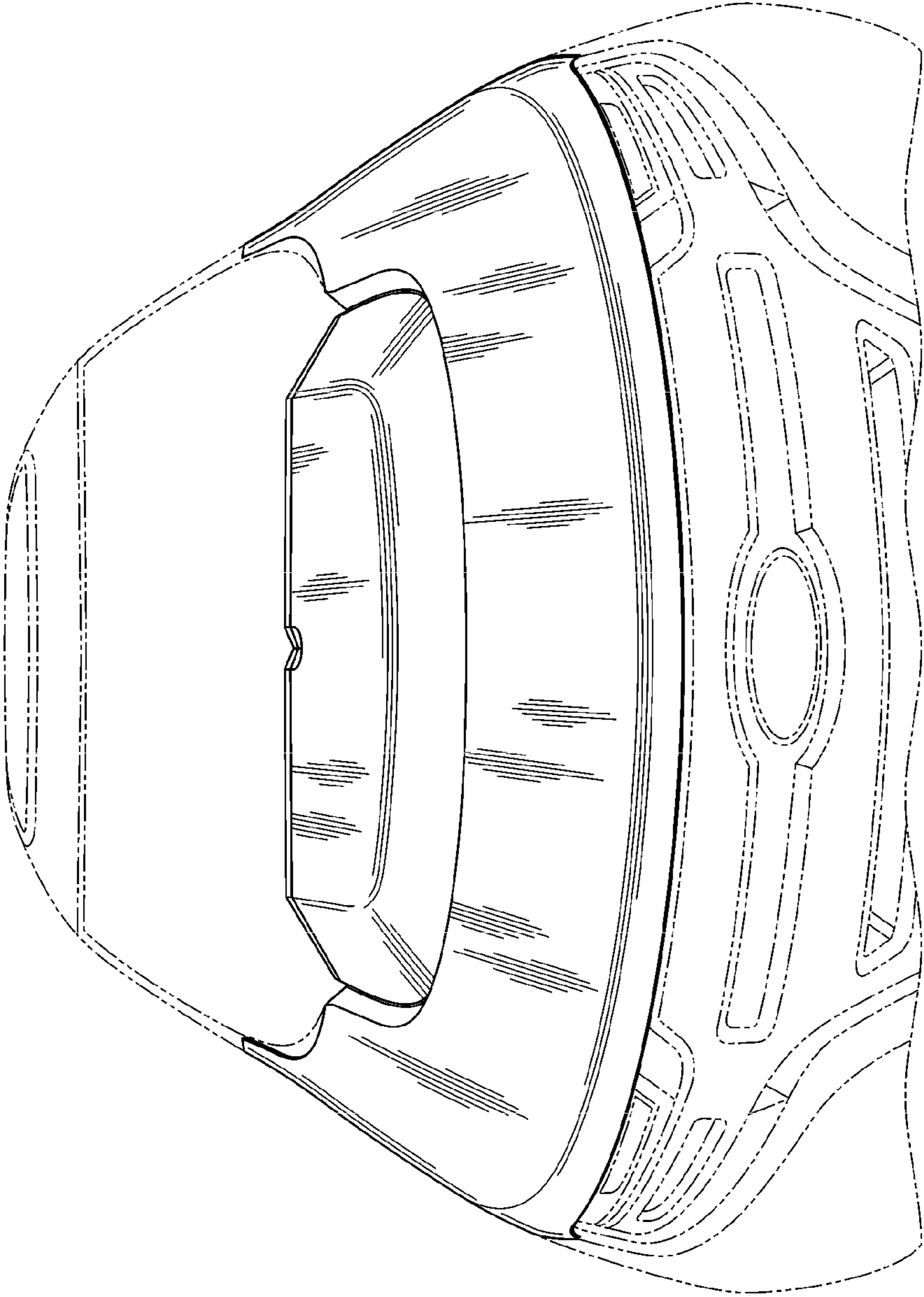

Fig. 1

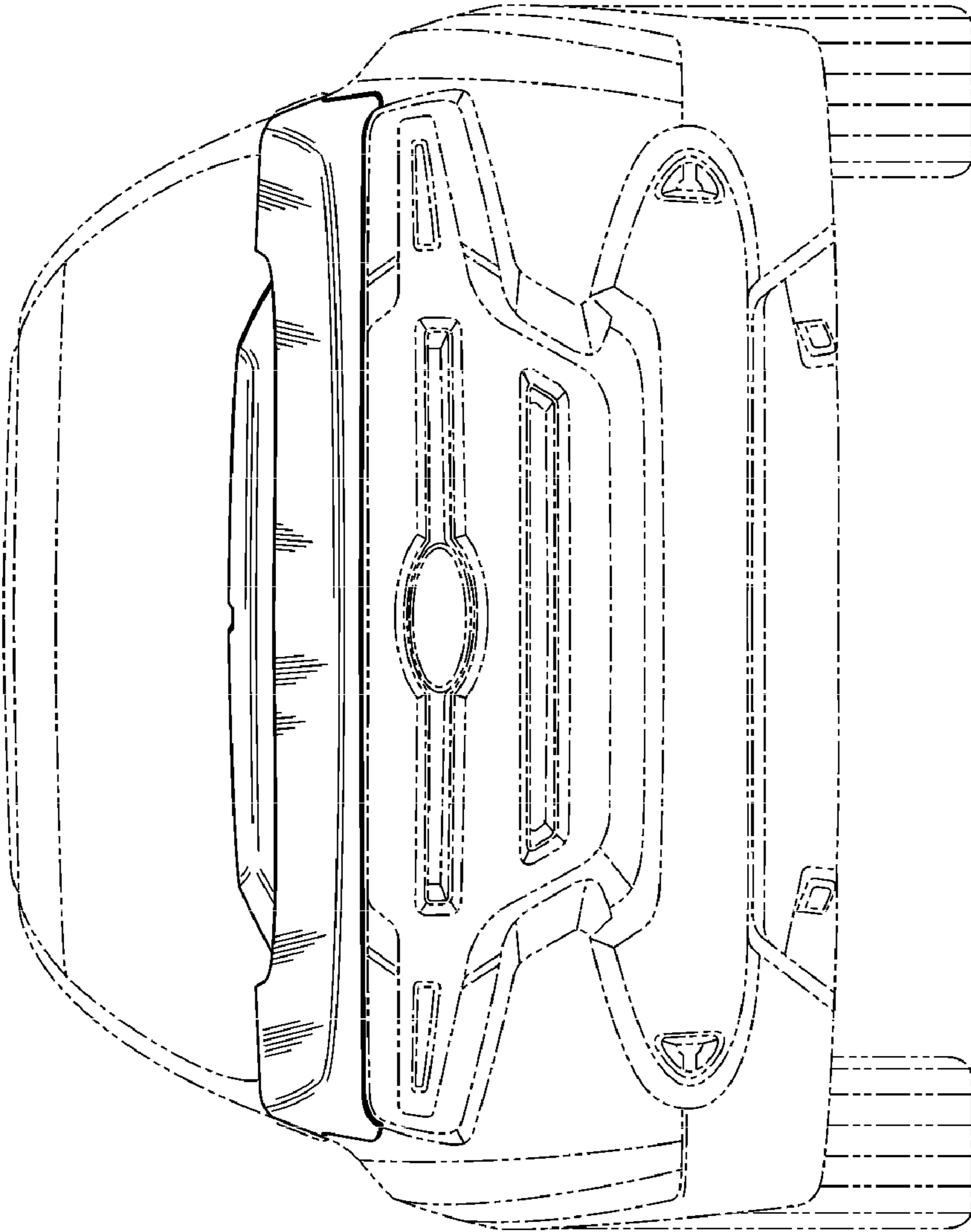

Fig. 2

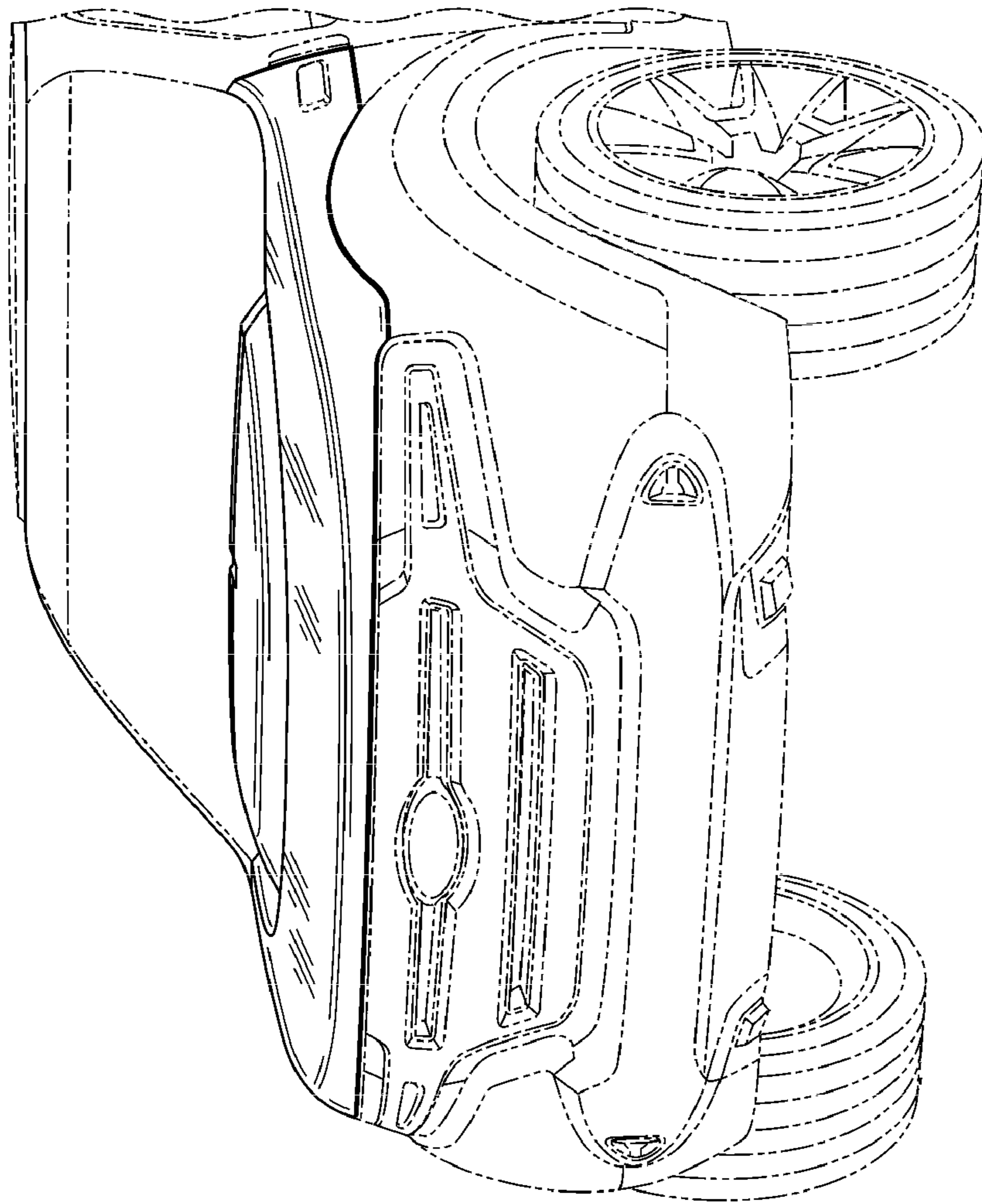

Fig. 3

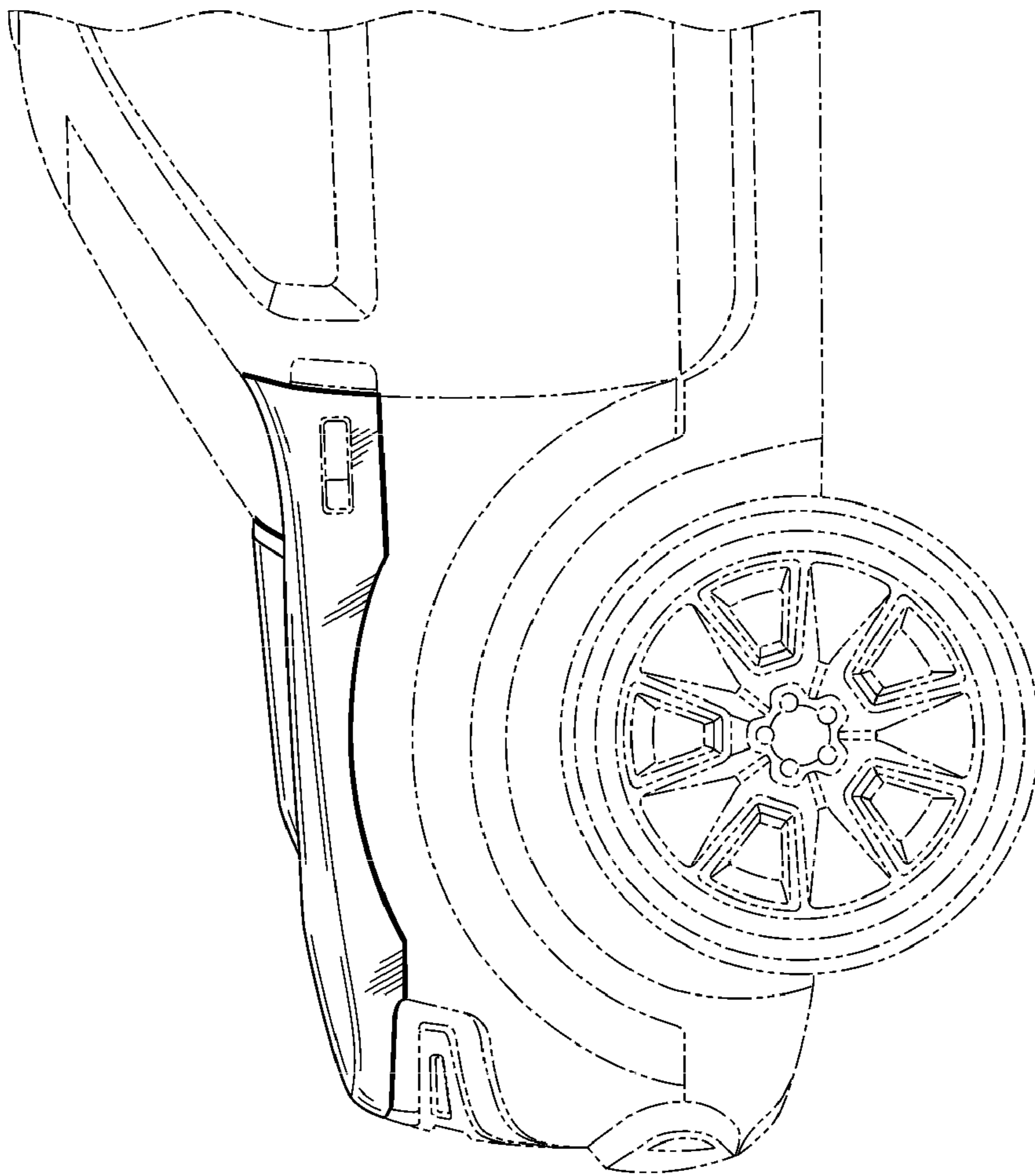

Fig. 4

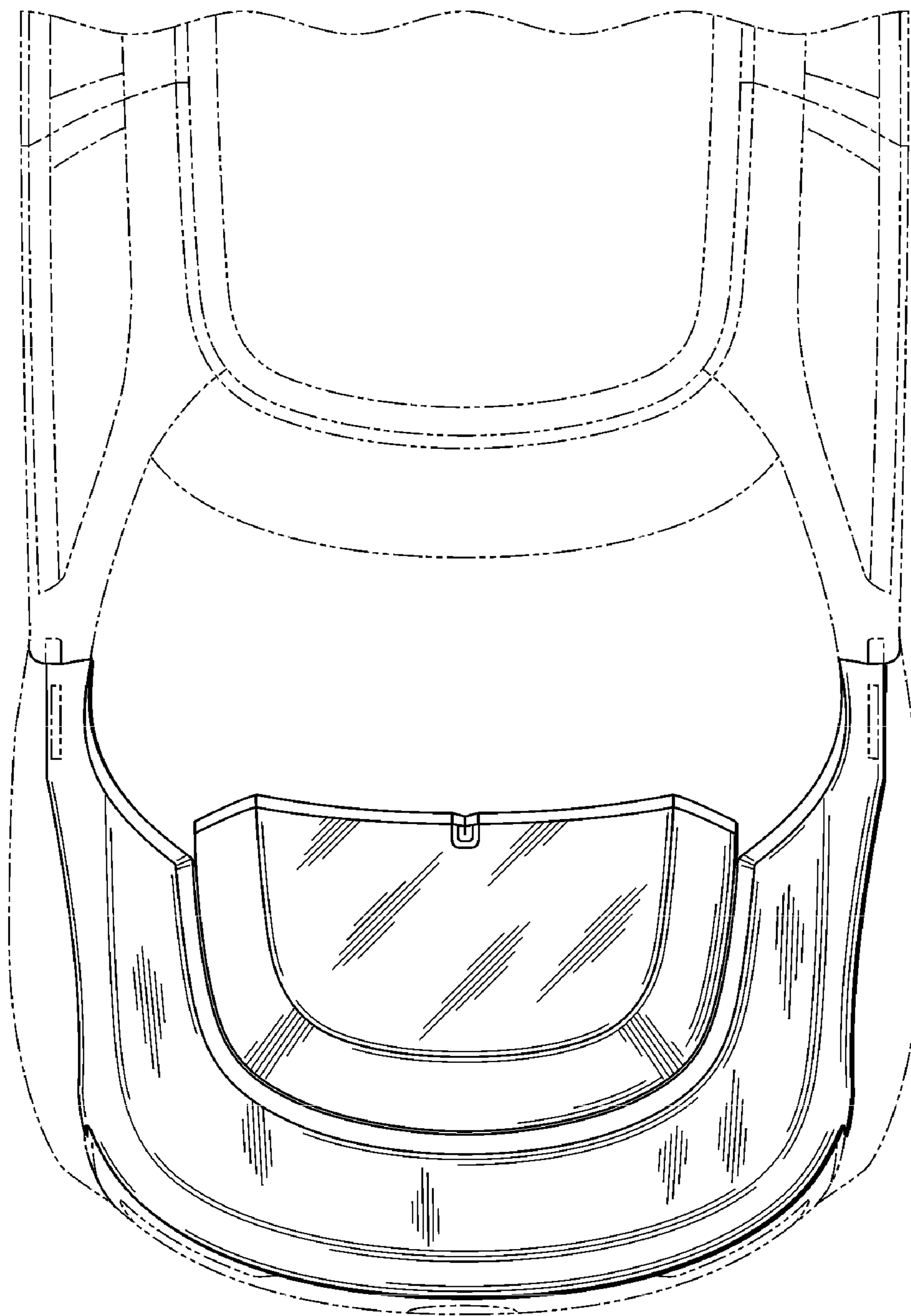

Fig. 5