



US00D596547S

(12) **United States Design Patent**
Passarotto et al.

(10) **Patent No.:** **US D596,547 S**
(45) **Date of Patent:** **** Jul. 21, 2009**

(54) **WHEEL OF A BICYCLE**
(75) Inventors: **Maurizio Passarotto**, Rovigo (IT);
Mario Meggiolan, Vicenza (IT)
(73) Assignee: **Campagnolo S.r.l.**, Vicenza (IT)
(**) Term: **14 Years**
(21) Appl. No.: **29/190,273**
(22) Filed: **Sep. 18, 2003**
(30) **Foreign Application Priority Data**
Mar. 18, 2003 (IT) TO2003O0070
(51) **LOC (9) Cl.** **12-16**
(52) **U.S. Cl.** **D12/205**
(58) **Field of Classification Search** D12/205,
D12/204, 501; 301/55, 56, 73, 64, 12.1,
301/12.2, 35.5, 35.56; 144/8; 384/545; 152/235,
152/238
See application file for complete search history.

(56) **References Cited**
U.S. PATENT DOCUMENTS
514,965 A * 2/1894 Rucker et al. 301/56
(Continued)
FOREIGN PATENT DOCUMENTS
GB 3014034 * 9/2003
Primary Examiner—Joel A. Sincavage
Assistant Examiner—Maurice Stevens
(74) *Attorney, Agent, or Firm*—Volpe and Koenig, P.C.

(57) **CLAIM**
The ornamental design for a wheel of a bicycle, as shown and described.

DESCRIPTION
FIG. 1 is a perspective drawing of a wheel of a bicycle showing our new design;
FIG. 2 is a front elevation thereof;
FIG. 3 is a top plan view thereof;
FIG. 4 is a rear elevation thereof;

FIG. 5 is a bottom plan view thereof;
FIG. 6 is a perspective drawing of a first modified embodiment of the design shown in FIGS. 1 through 5;
FIG. 7 is a front elevation thereof;
FIG. 8 is a top plan view thereof;
FIG. 9 is a rear elevation thereof;
FIG. 10 is a bottom plan view thereof;
FIG. 11 is a perspective drawing of a second modified embodiment of the design shown in FIGS. 1 through 5;
FIG. 12 is a front elevation thereof;
FIG. 13 is a top plan view thereof;
FIG. 14 is a rear elevation thereof;
FIG. 15 is a bottom plan view thereof;
FIG. 16 is a perspective drawing of a third modified embodiment of the design shown in FIGS. 1 through 5;
FIG. 17 is a front elevation thereof;
FIG. 18 is a top plan view thereof;
FIG. 19 is a rear elevation thereof;
FIG. 20 is a bottom plan view thereof;
FIG. 21 is a perspective drawing of a fourth modified embodiment of the design shown in FIGS. 1 through 5;
FIG. 22 is a front elevation thereof;
FIG. 23 is a top plan view thereof;
FIG. 24 is a rear elevation thereof;
FIG. 25 is a bottom plan view thereof;
FIG. 26 is a perspective view of a fifth modified embodiment of the design shown in FIGS. 1 through 5;
FIG. 27 is a front elevation thereof;
FIG. 28 is a top plan view thereof;
FIG. 29 is a rear elevation thereof; and,
FIG. 30 is a bottom plan view thereof.
The broken lines are for illustrative purposes only and form no part of the claimed design.

1 Claim, 18 Drawing Sheets

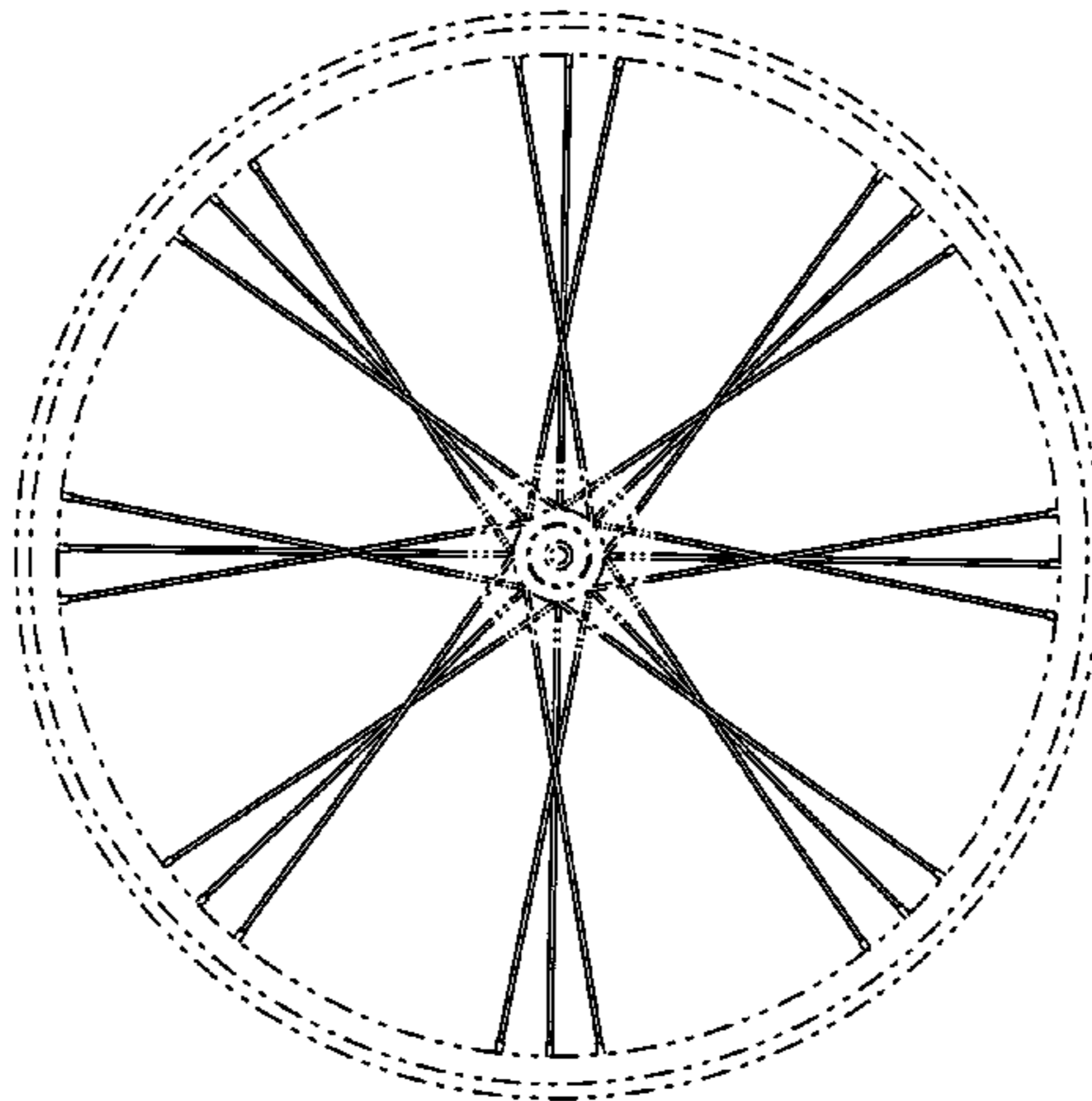

US D596,547 S

Page 2

U.S. PATENT DOCUMENTS					
		1,862,804 A *	6/1932	Pugh	301/55
		D472,507 S *	4/2003	Passarotto	D12/205
1,375,267 A *	4/1921	Weil			
1,634,700 A *	7/1927	Williams			219/78.16
1,836,818 A *	12/1931	Sauzedde			301/56
		2002/0074853 A1 *	6/2002	Krampera	301/55

* cited by examiner

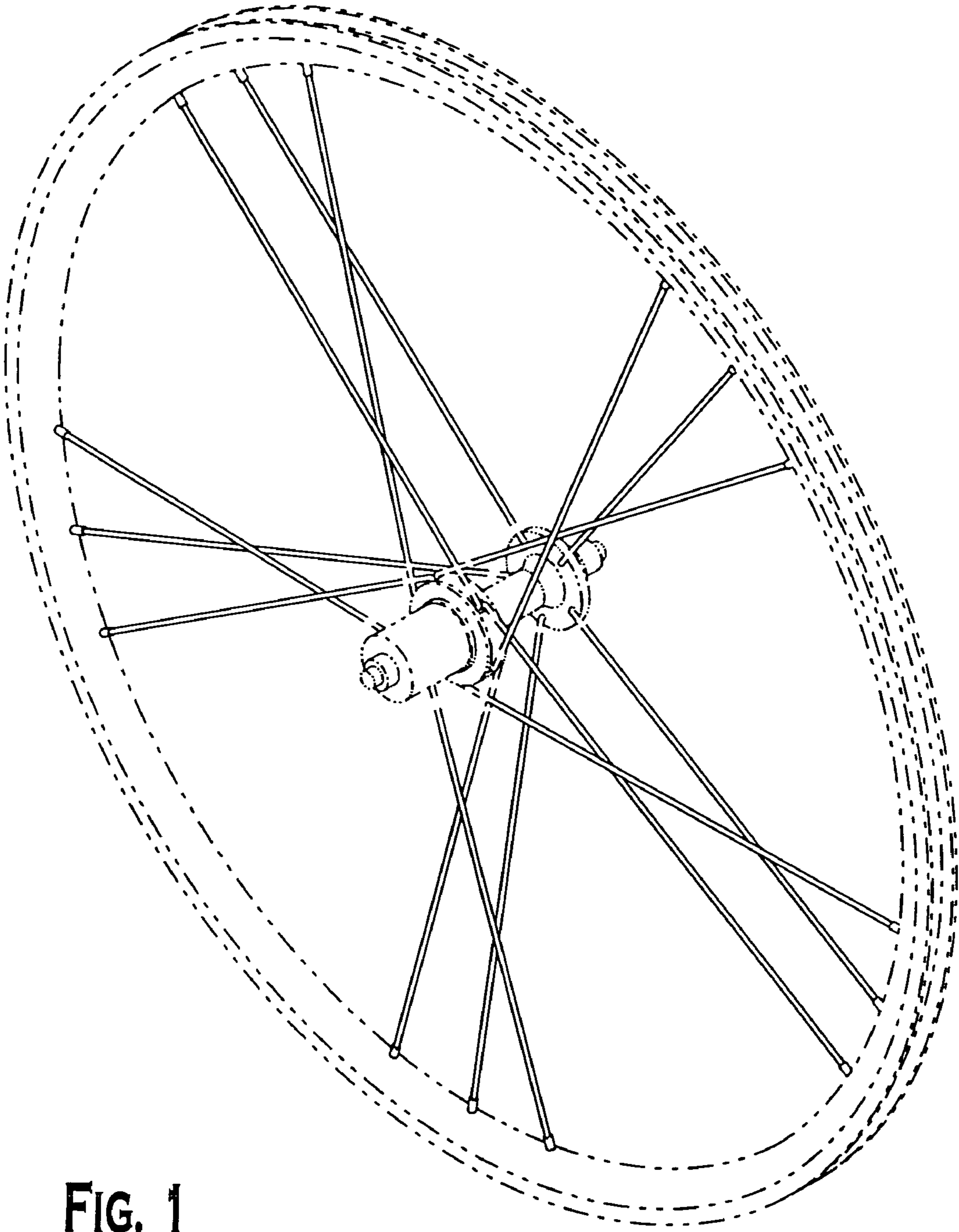

FIG. 1

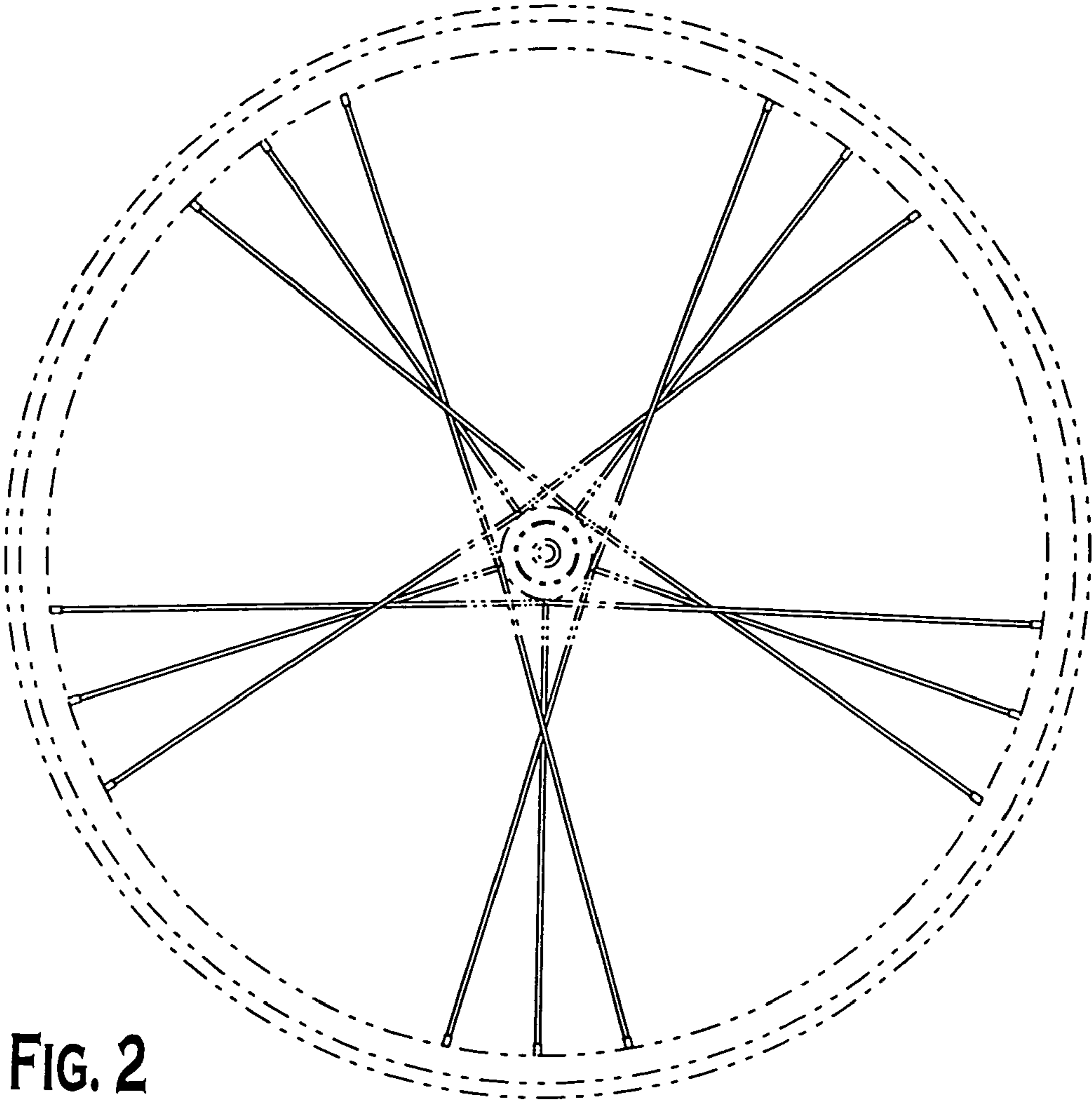

FIG. 2

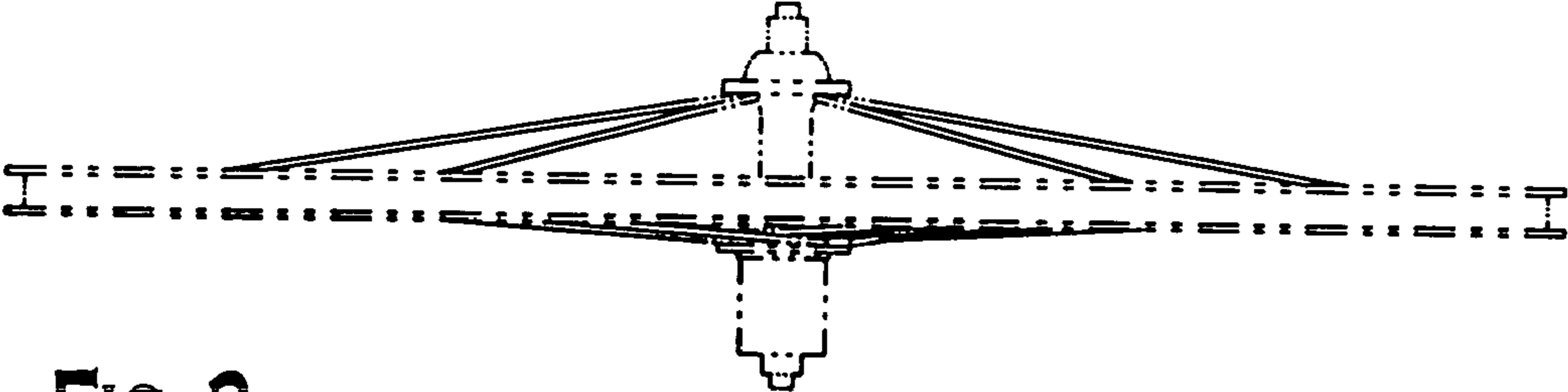

FIG. 3

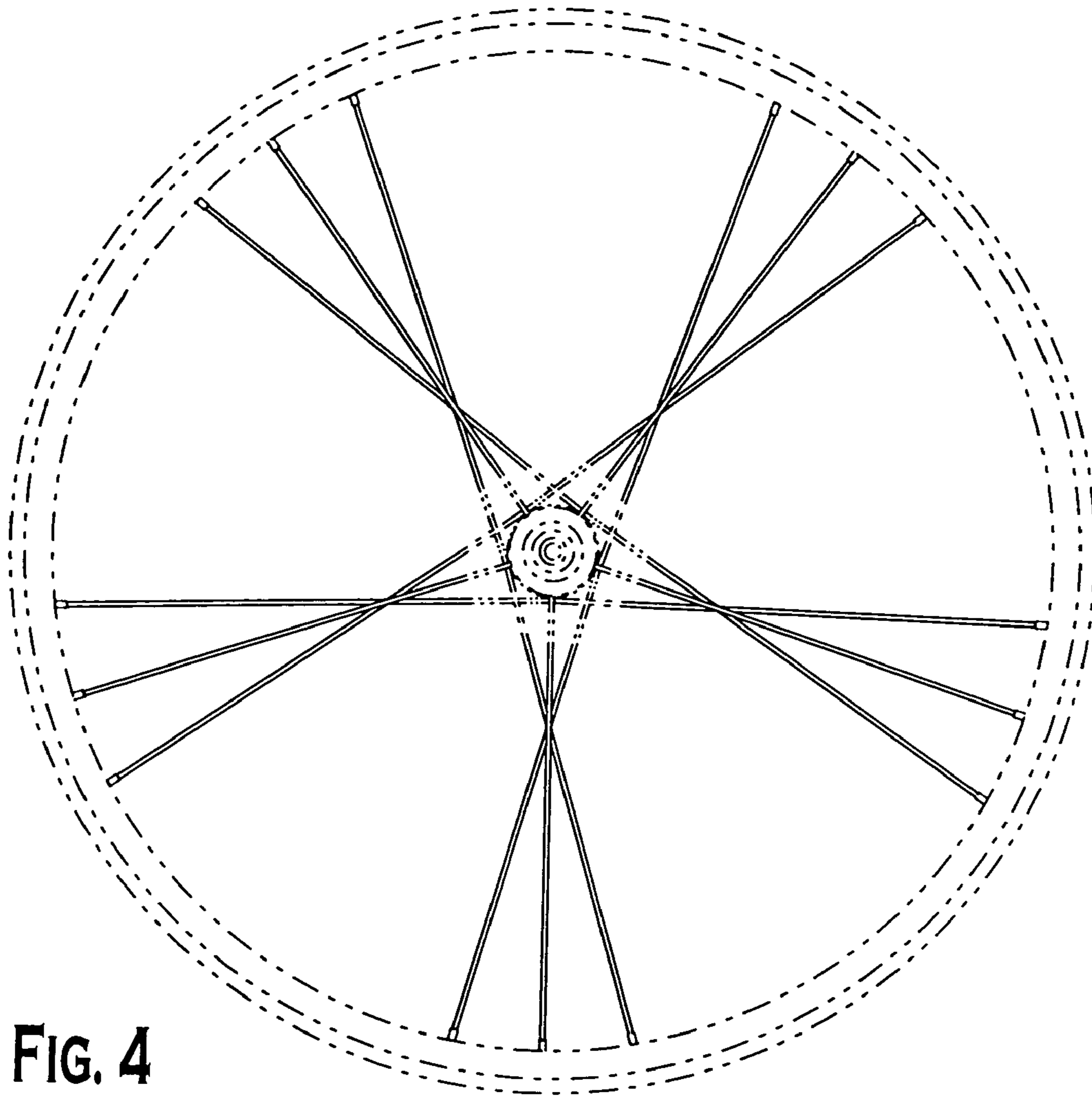

FIG. 4

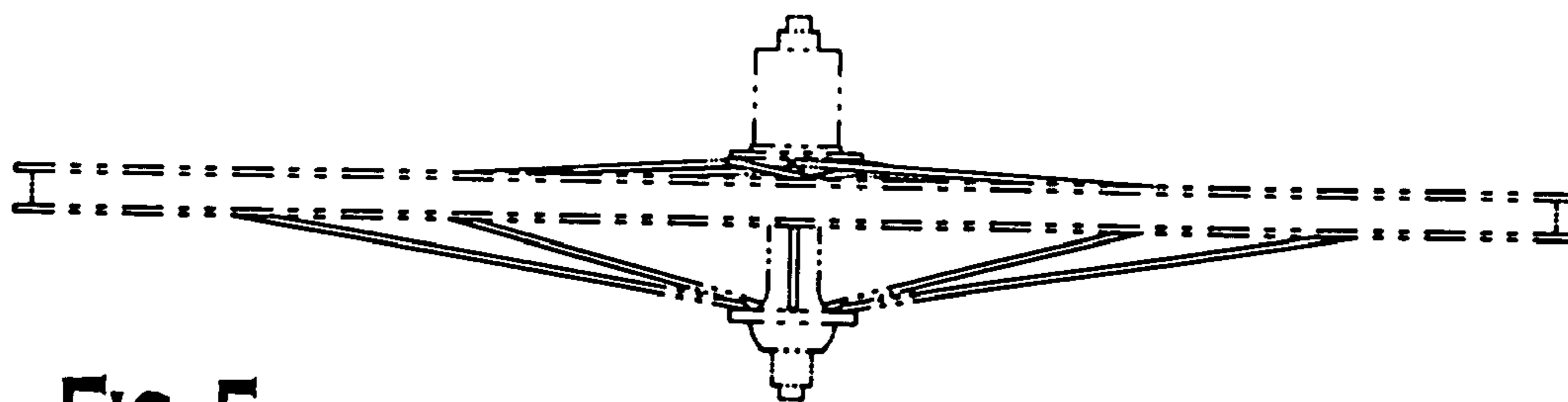

FIG. 5

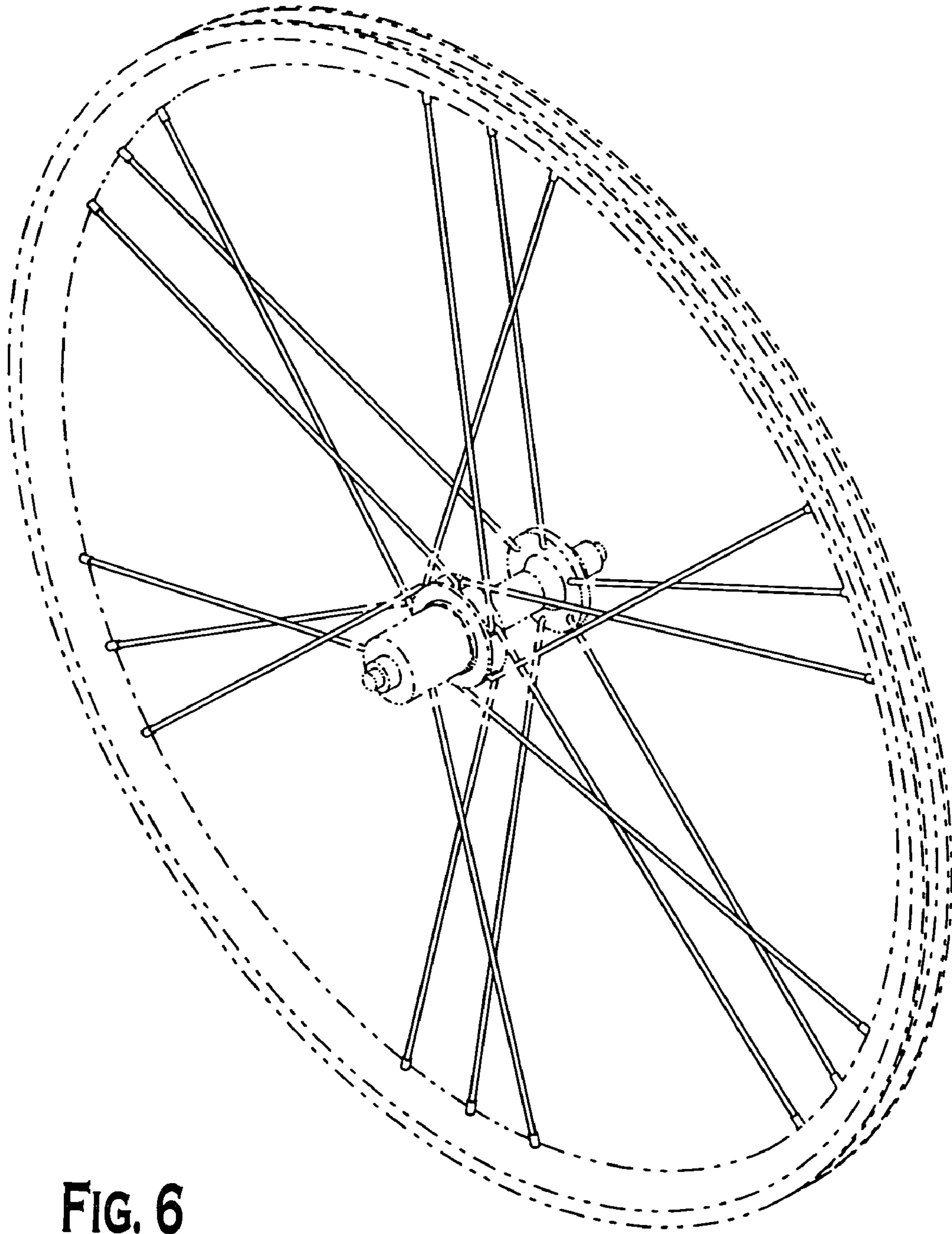

FIG. 6

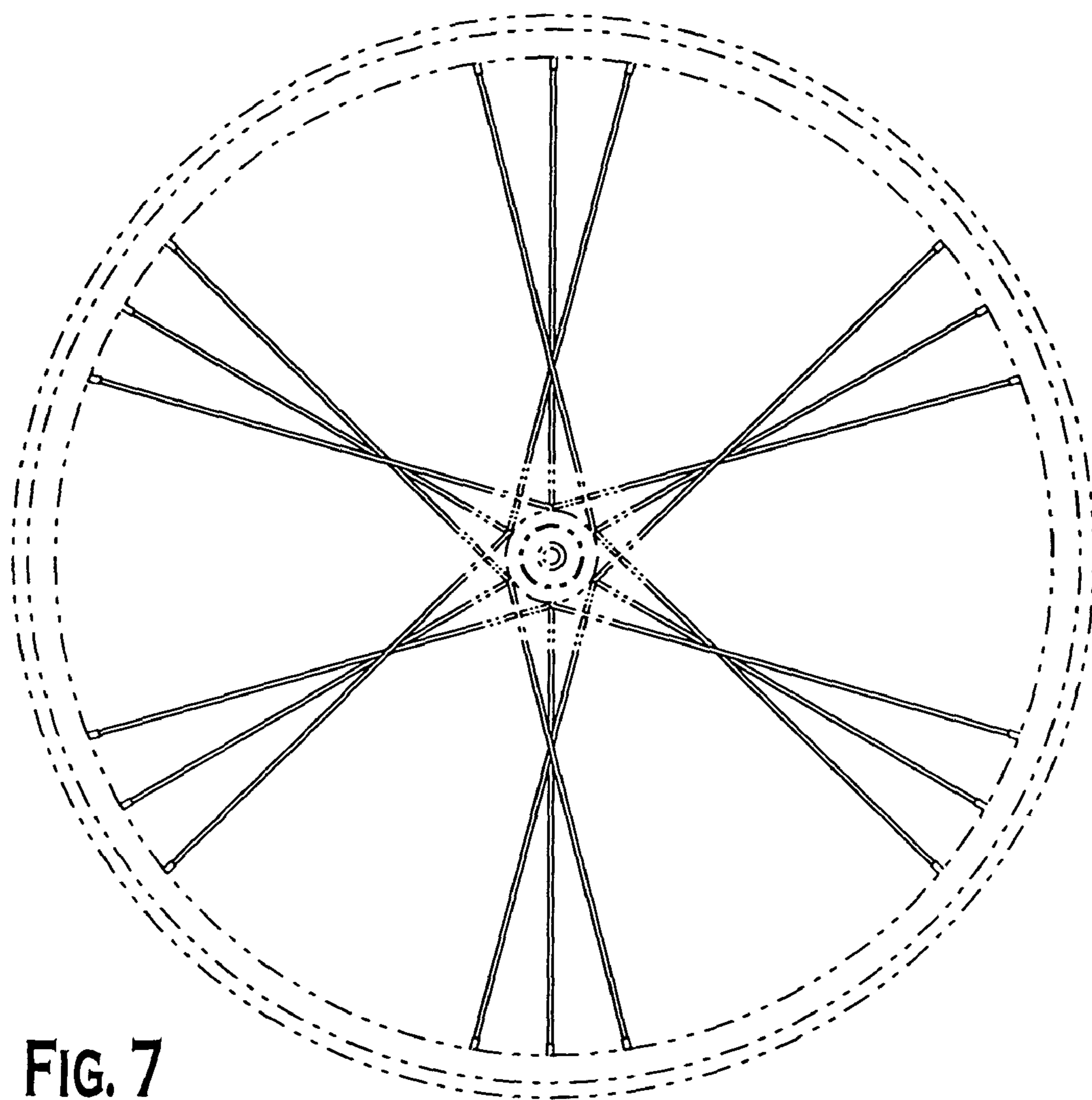

FIG. 7

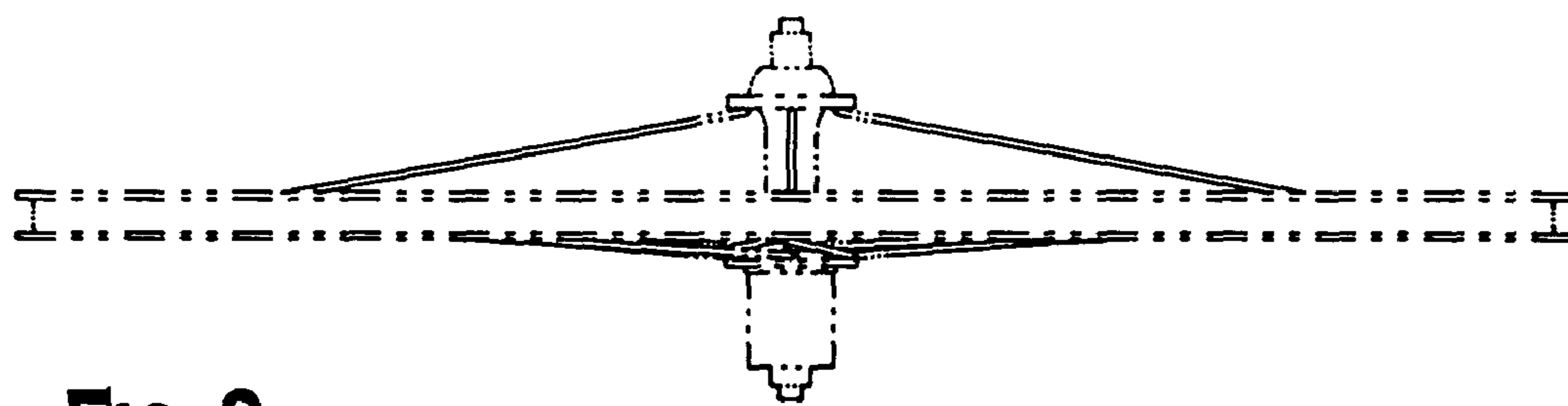

FIG. 8

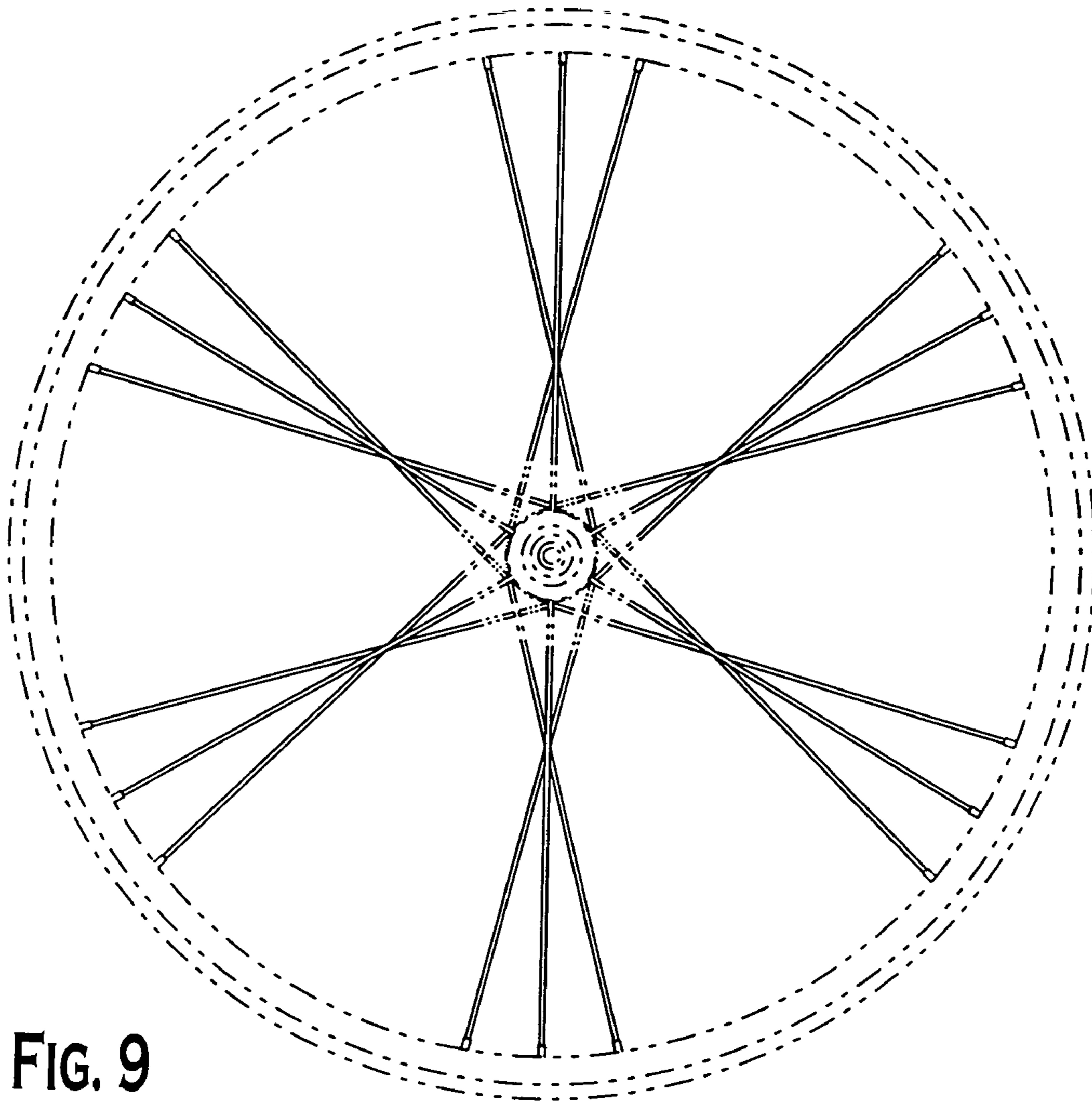

FIG. 9

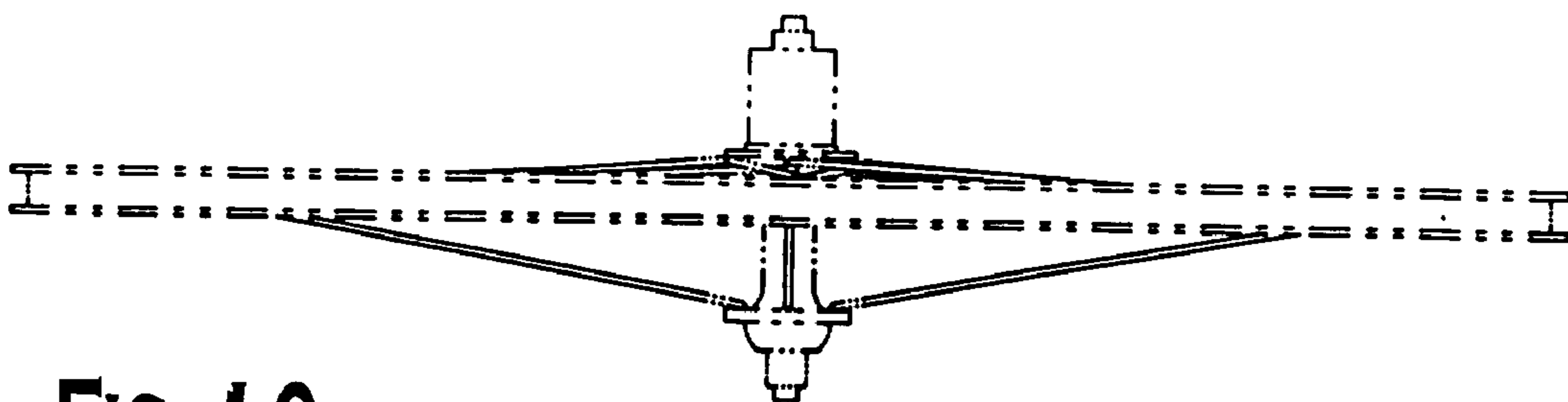

FIG. 10

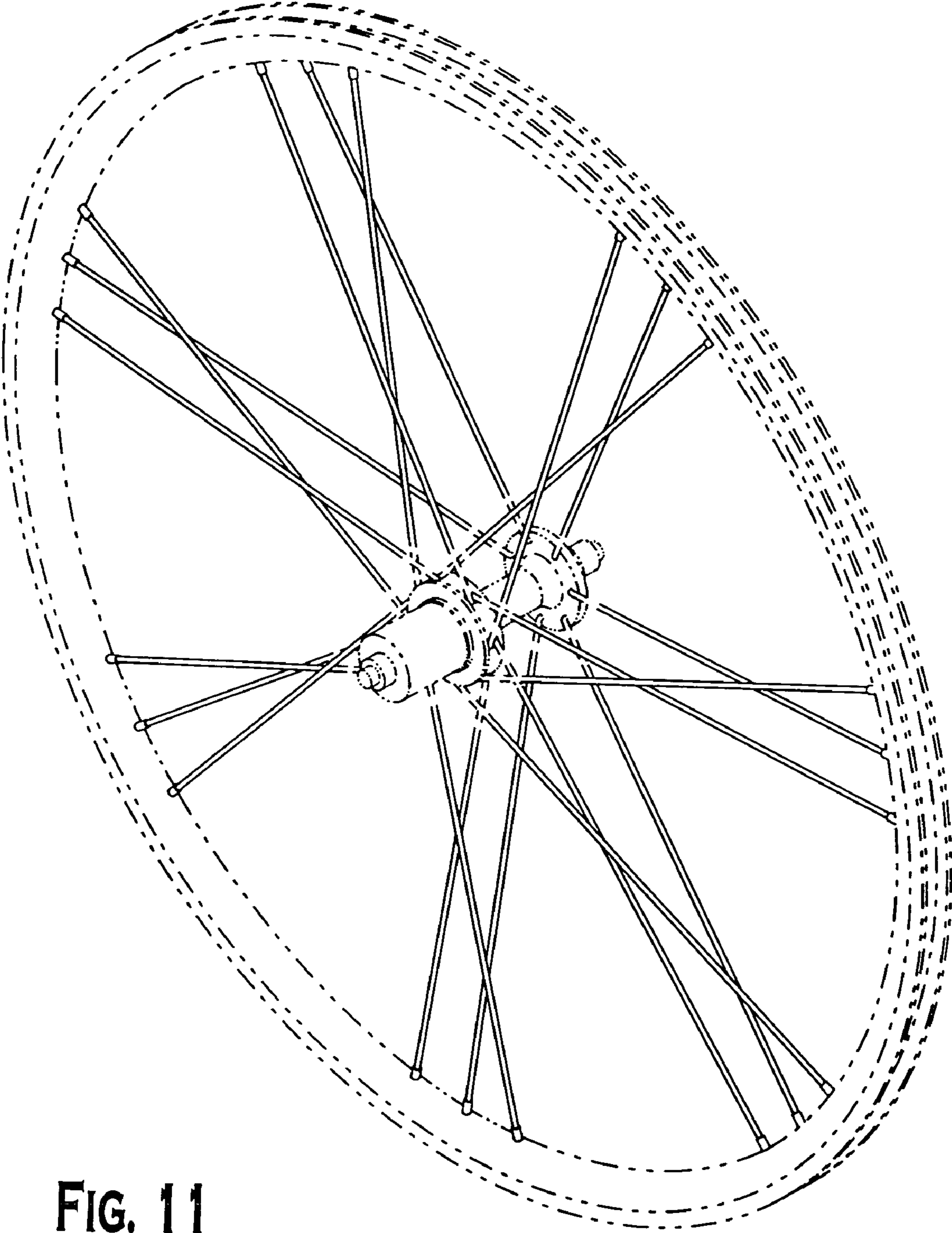

FIG. 11

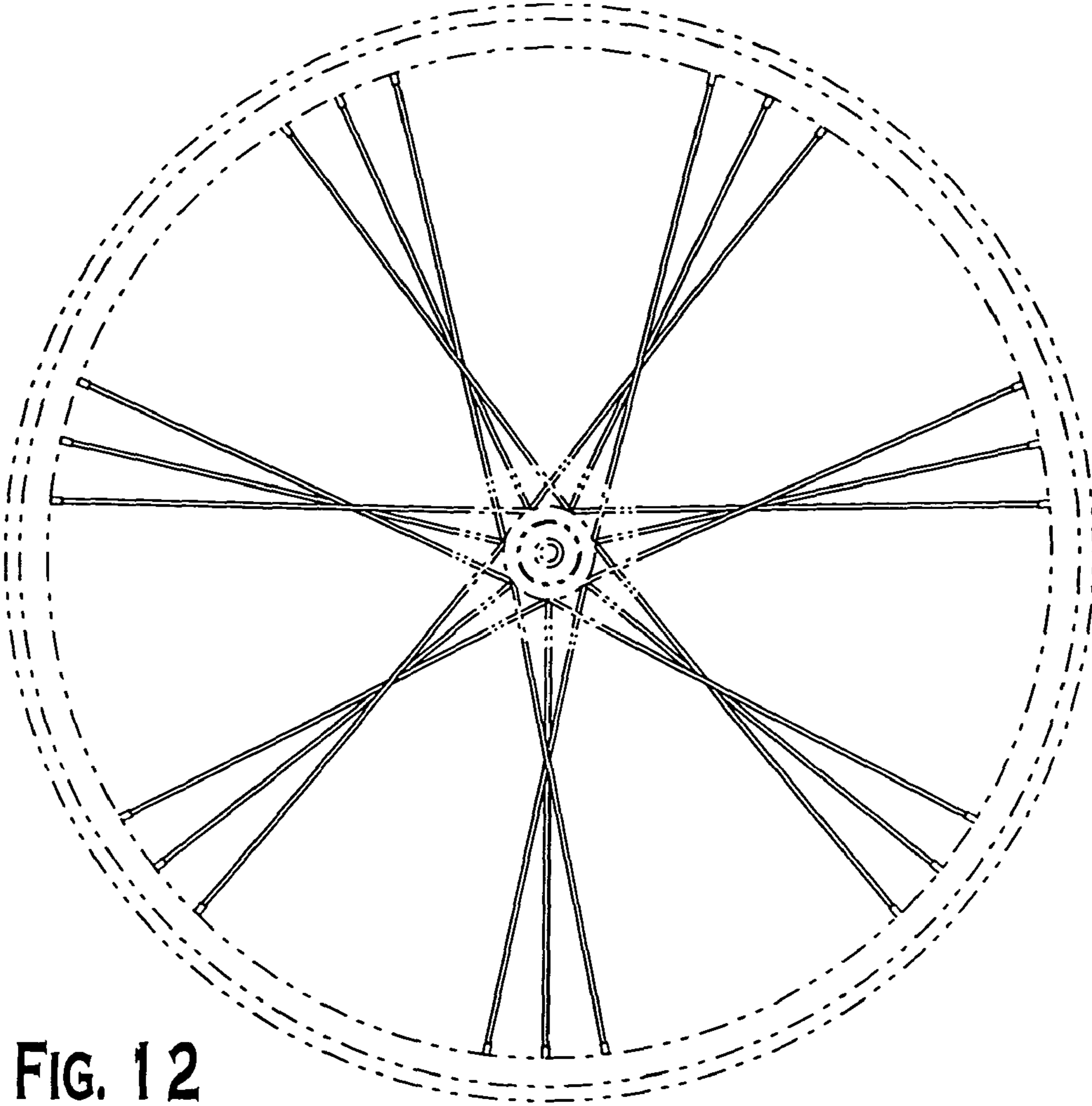

FIG. 12

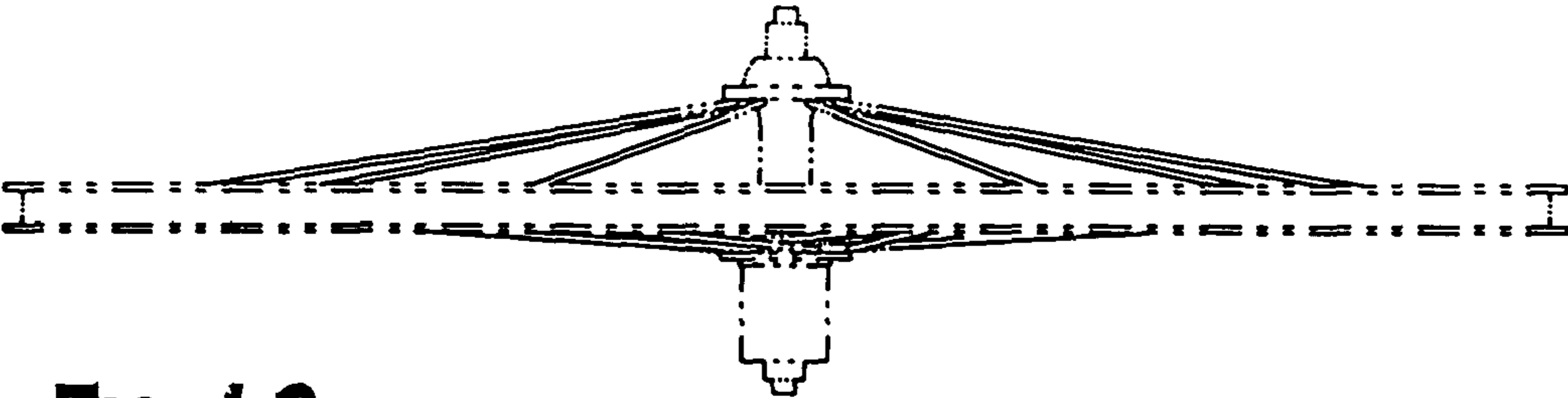

FIG. 13

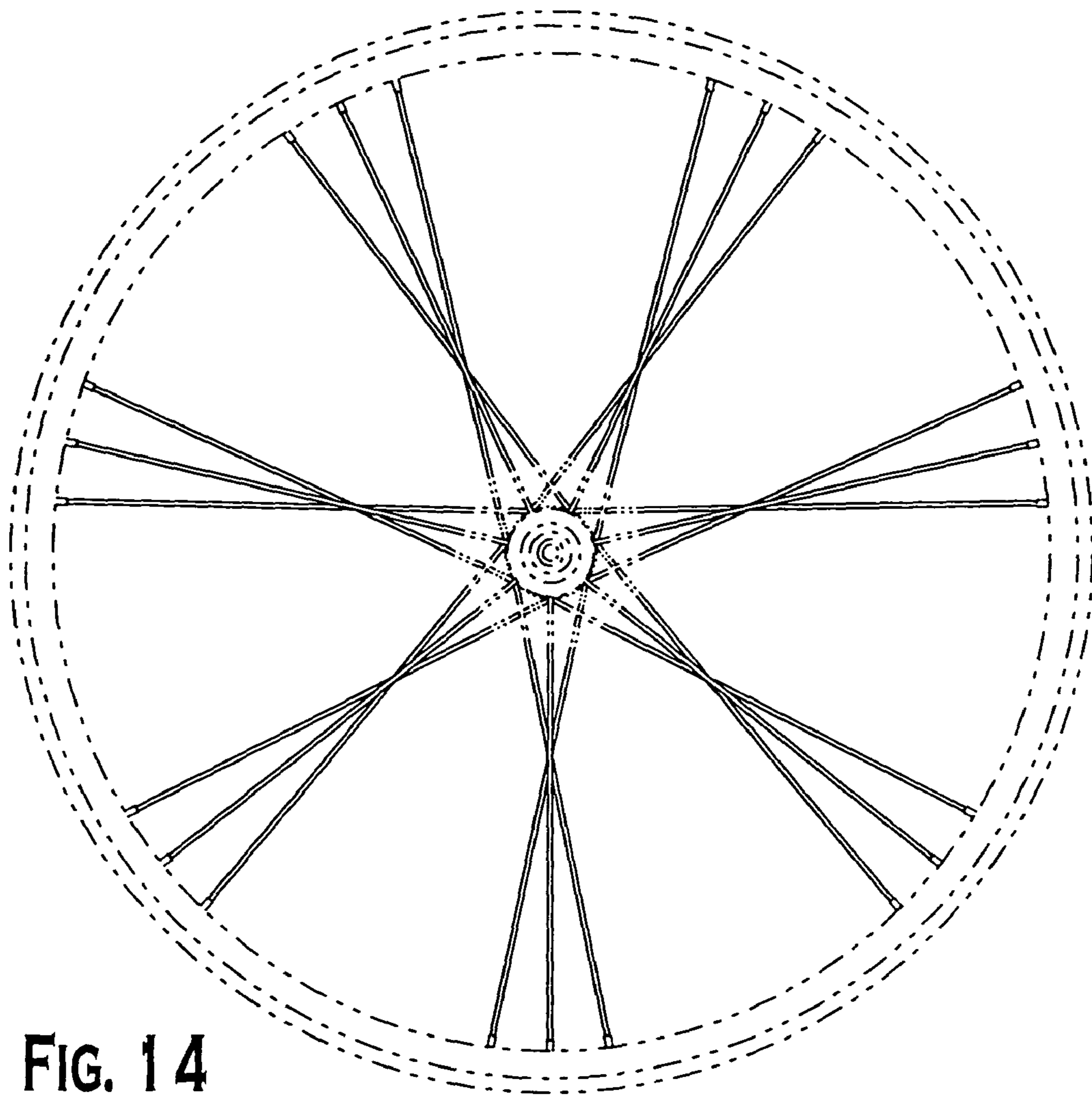

FIG. 14

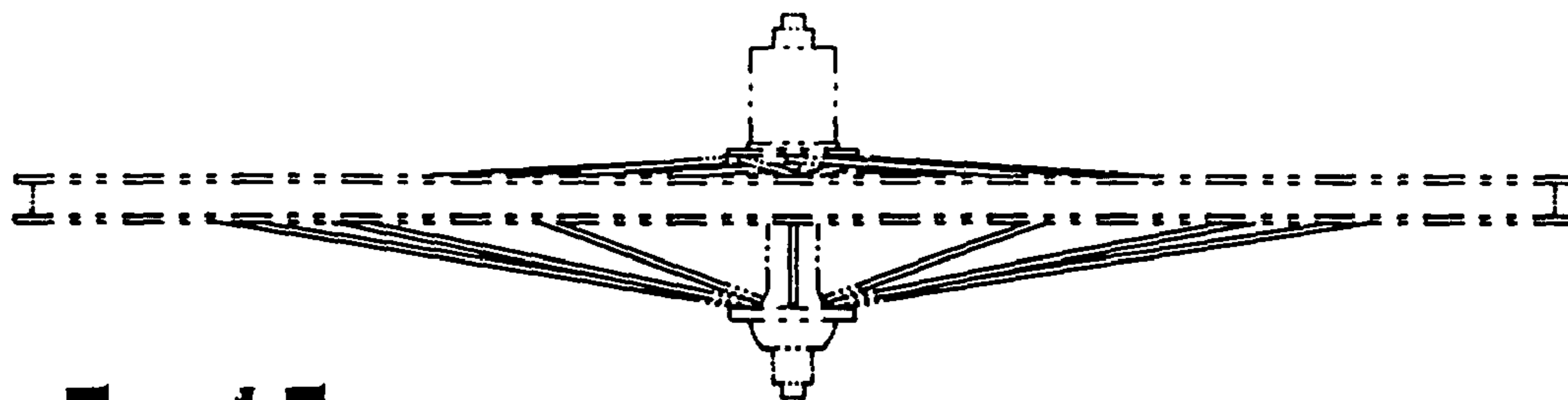

FIG. 15

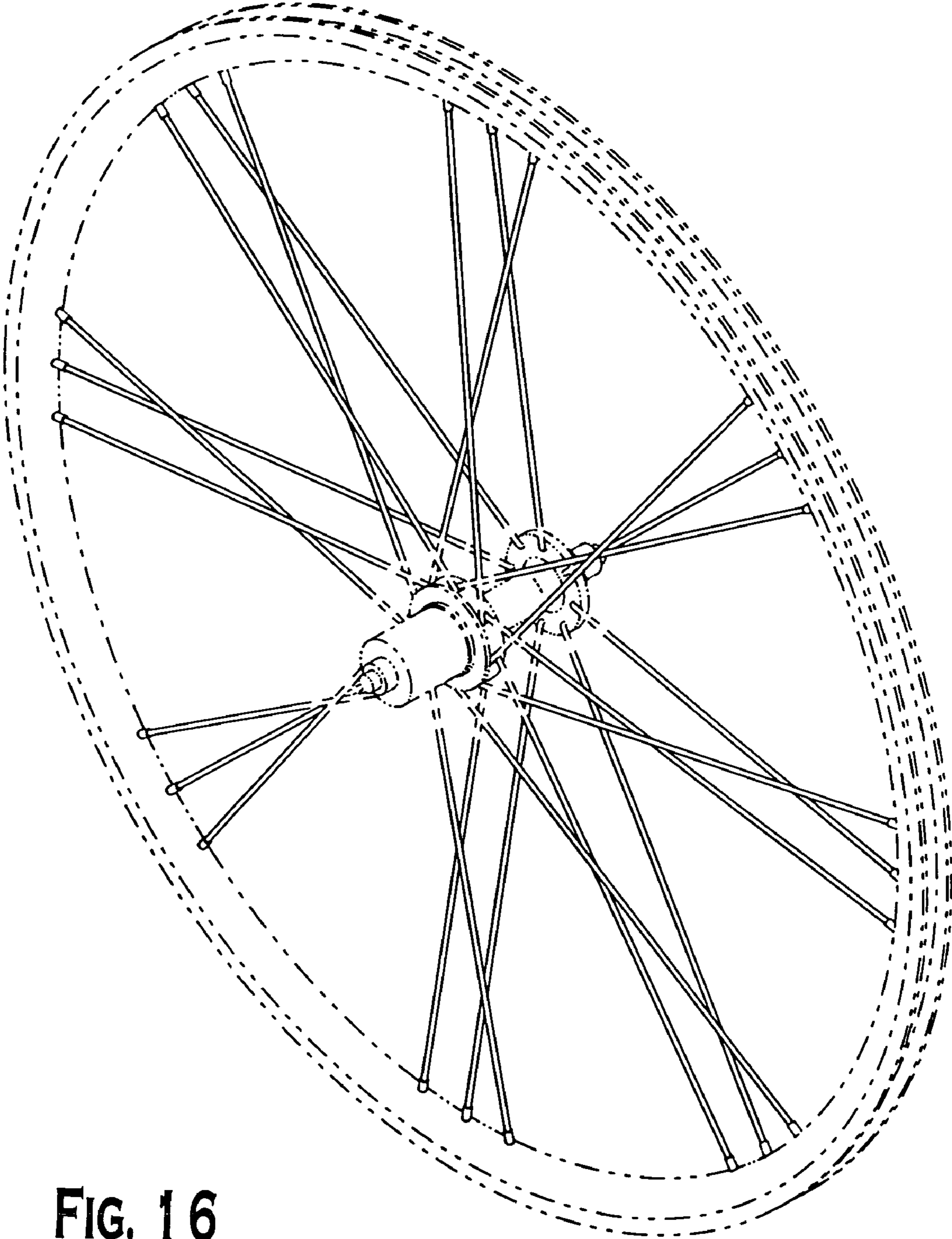

FIG. 16

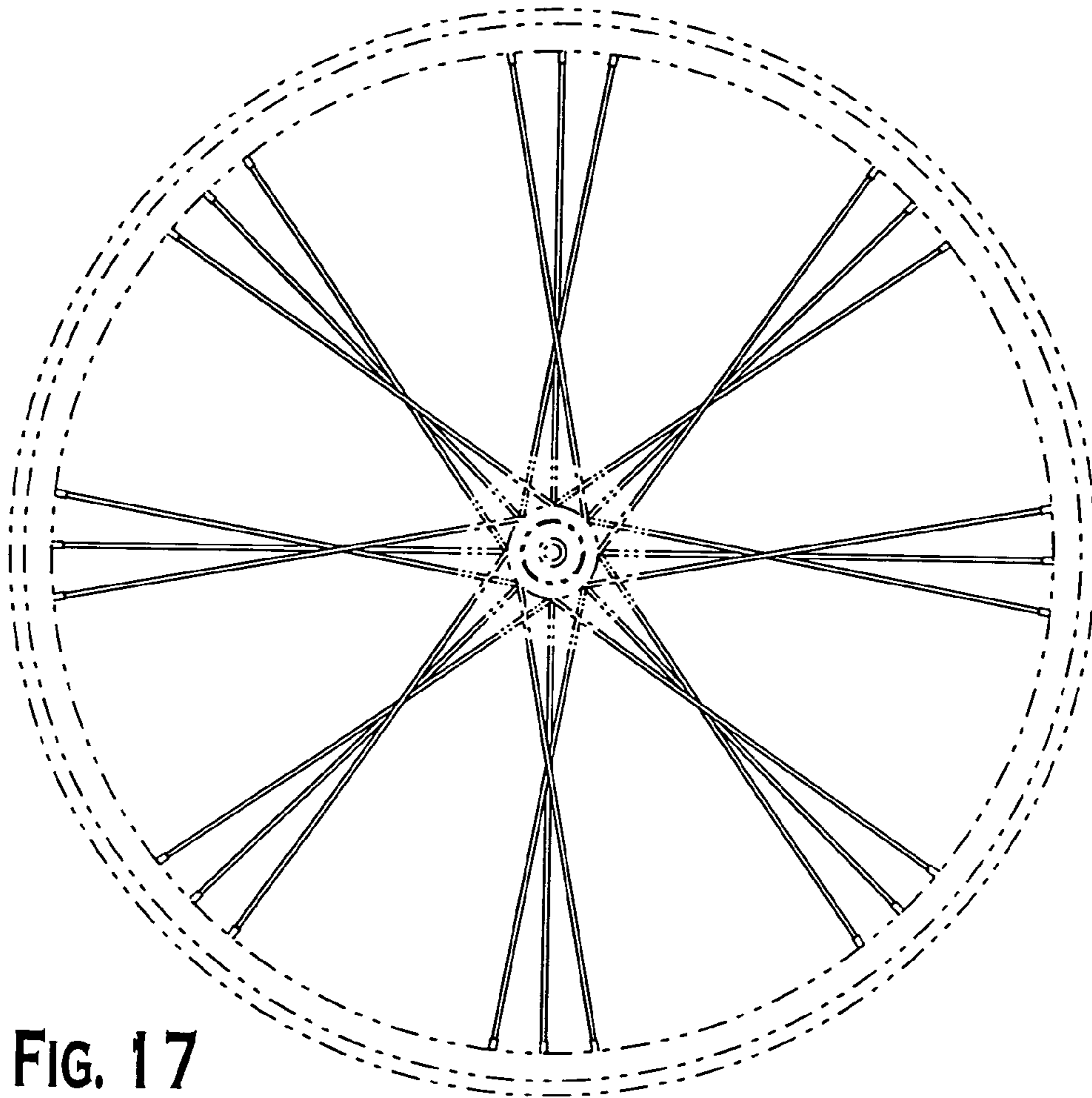

FIG. 17

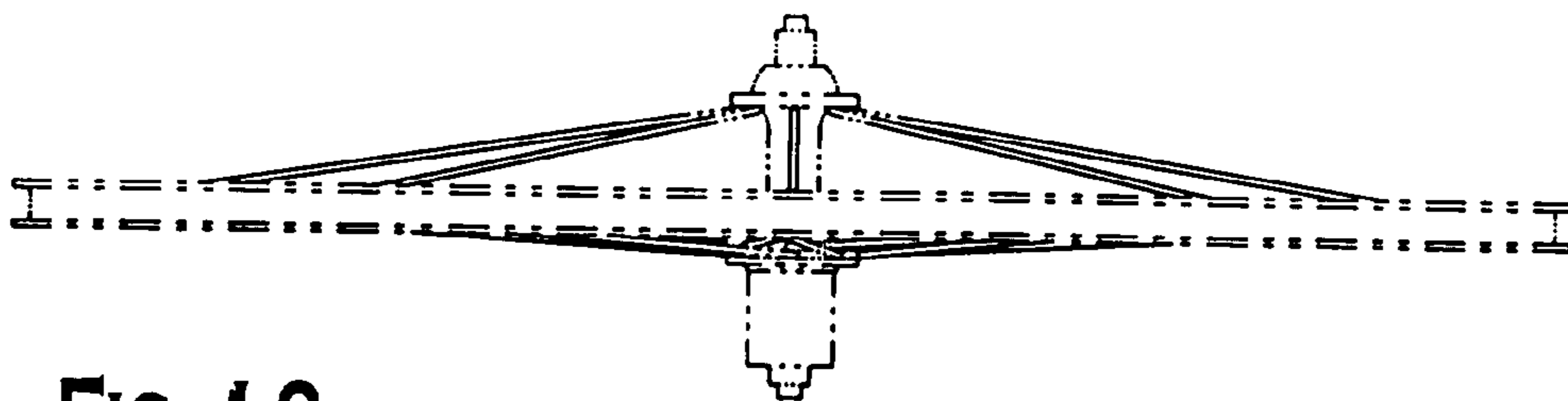
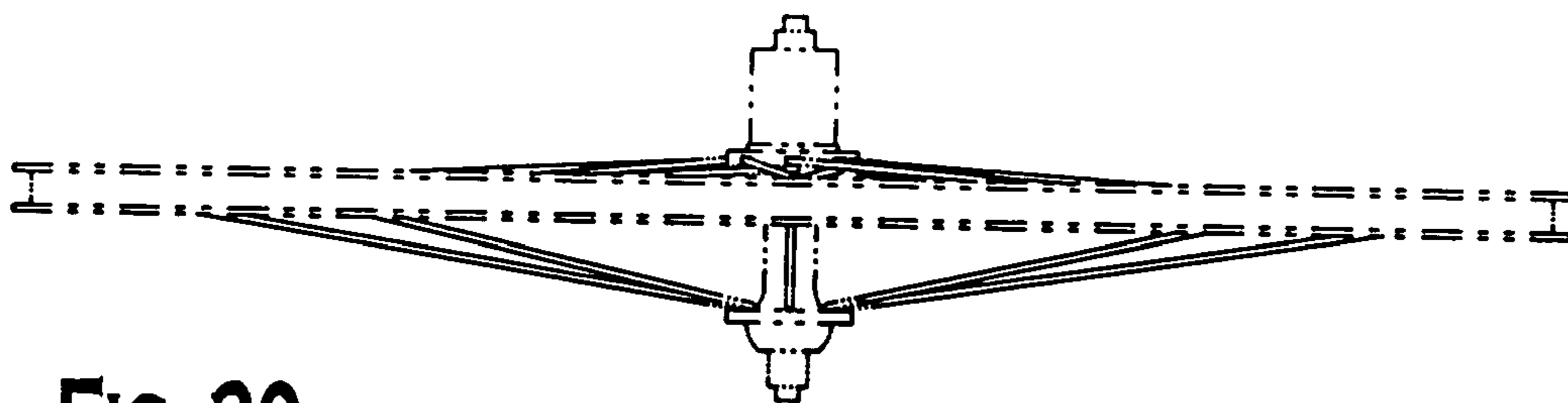
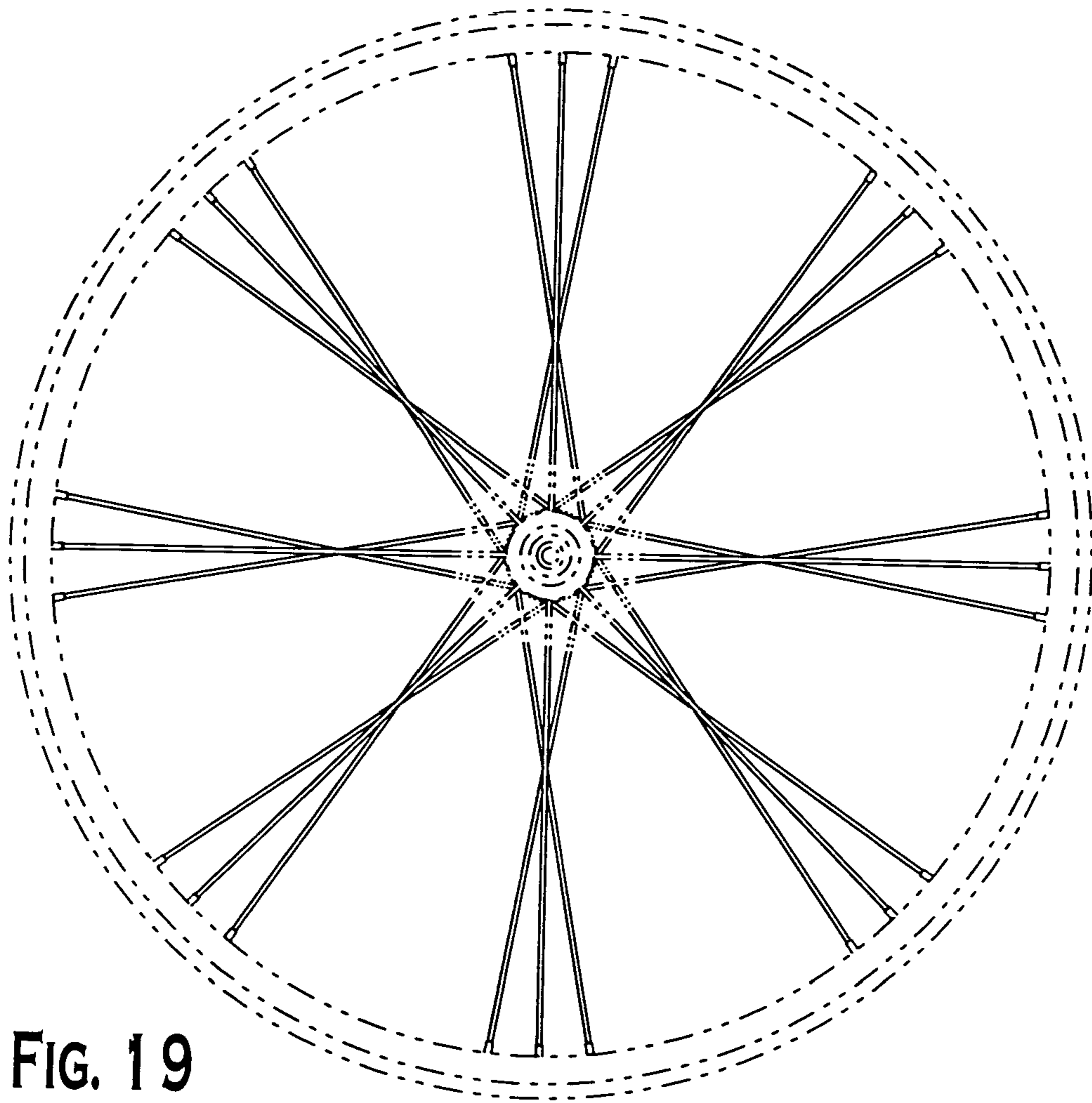

FIG. 18



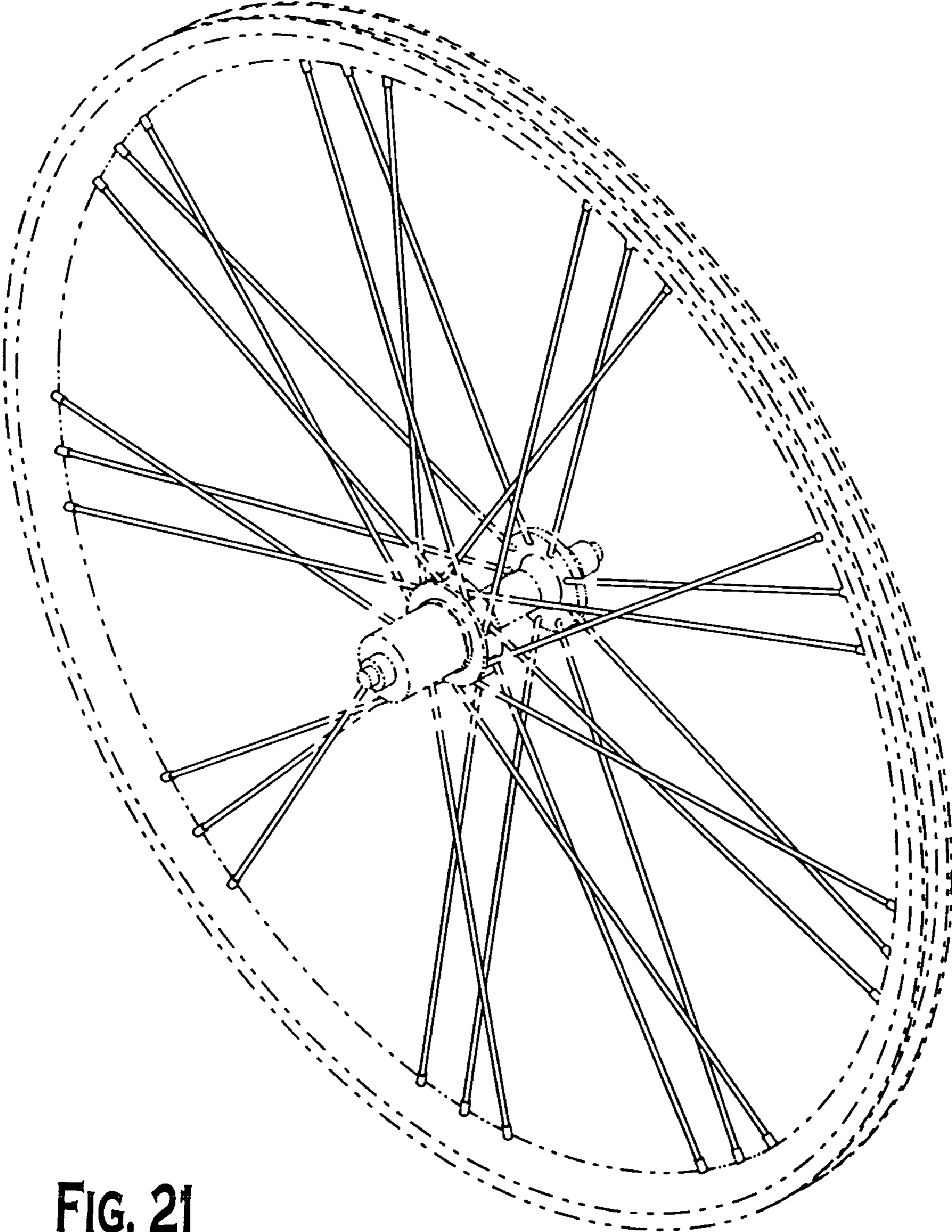

FIG. 21

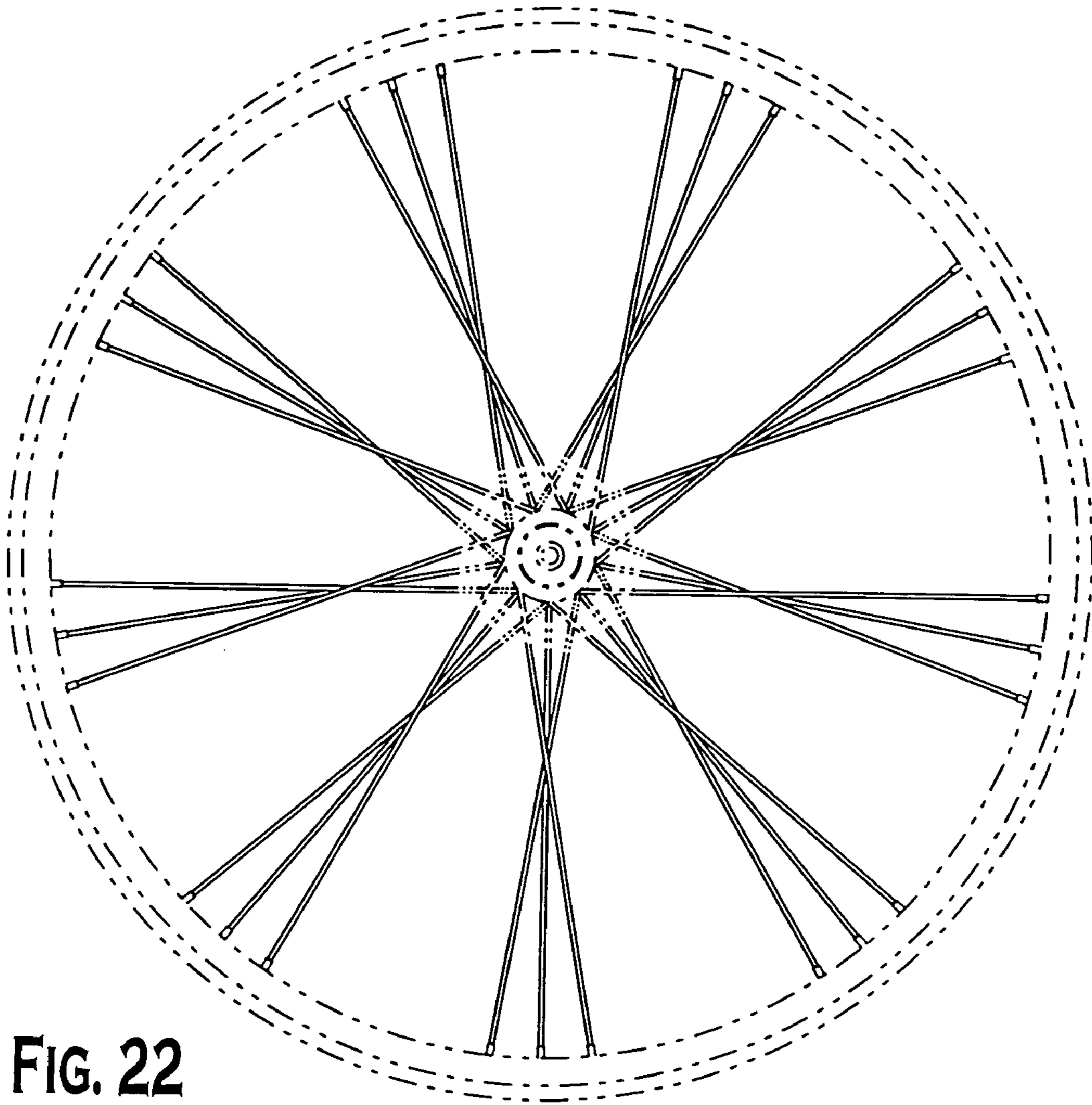

FIG. 22

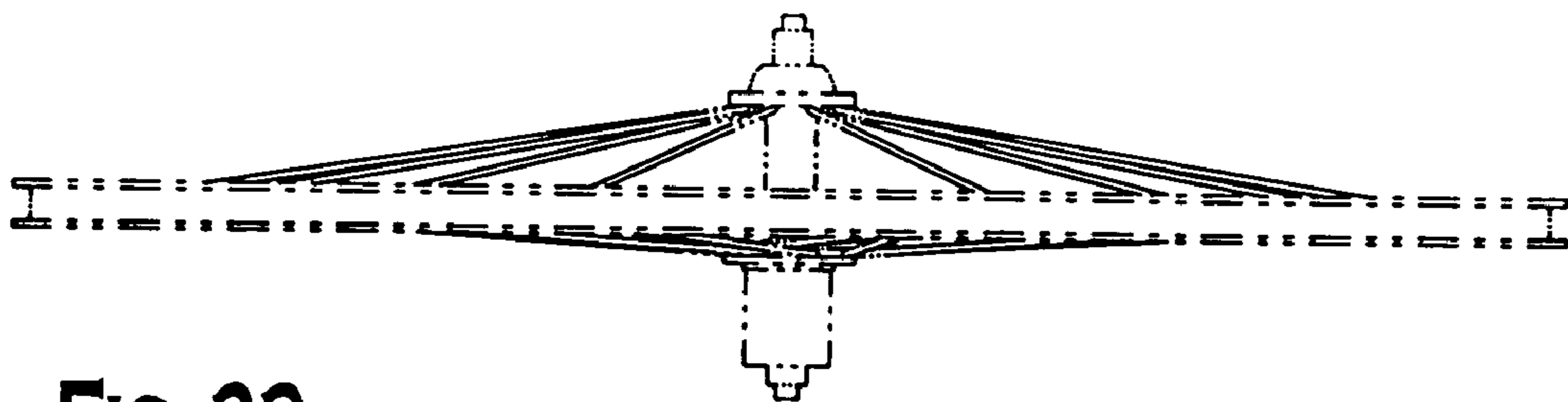

FIG. 23

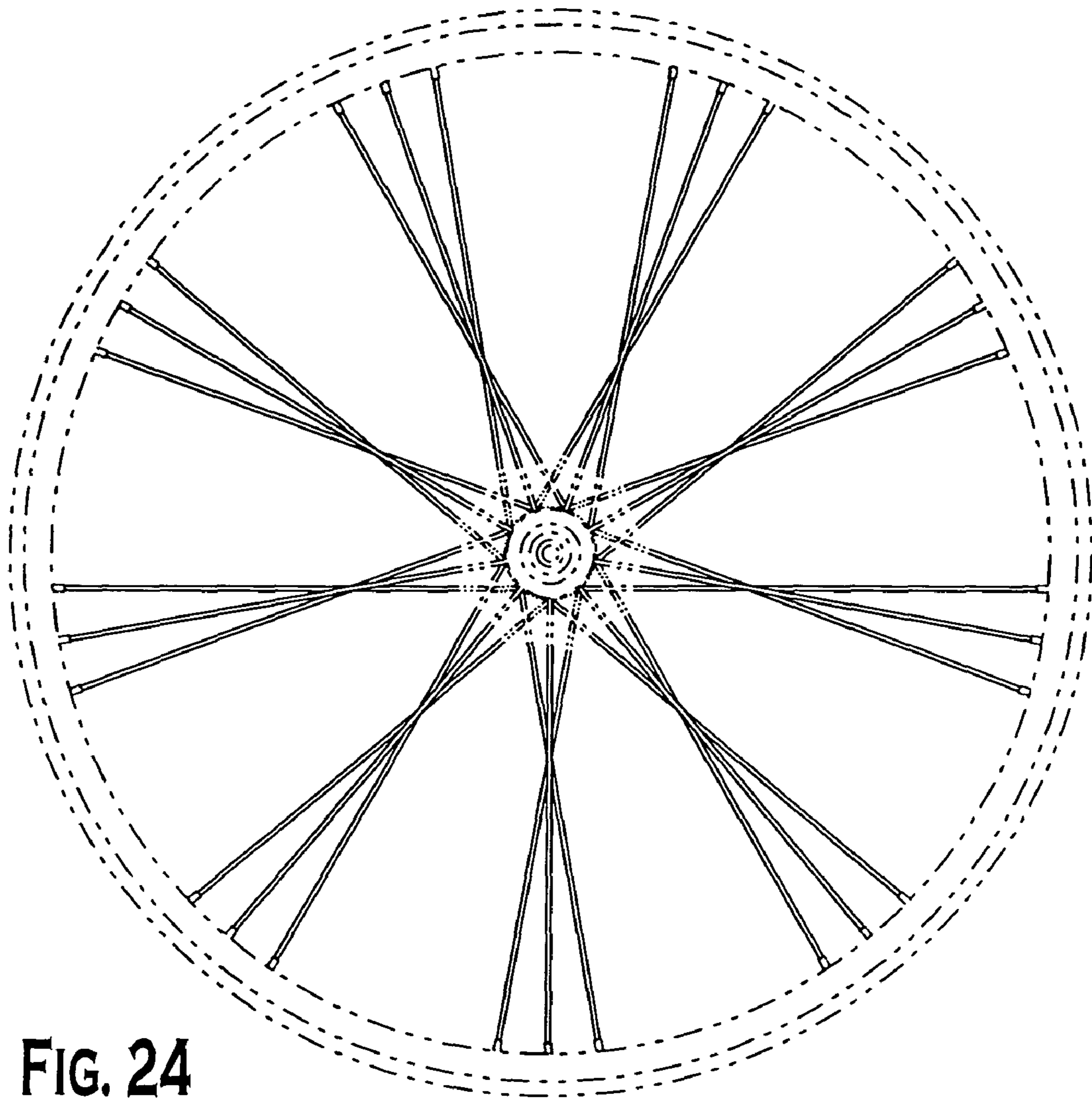

FIG. 24

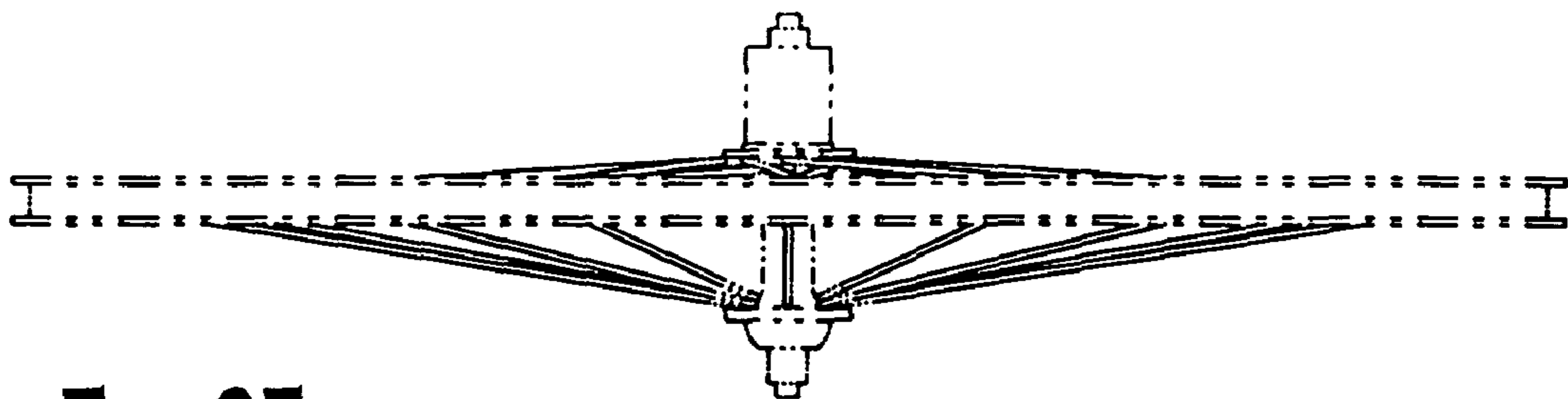

FIG. 25

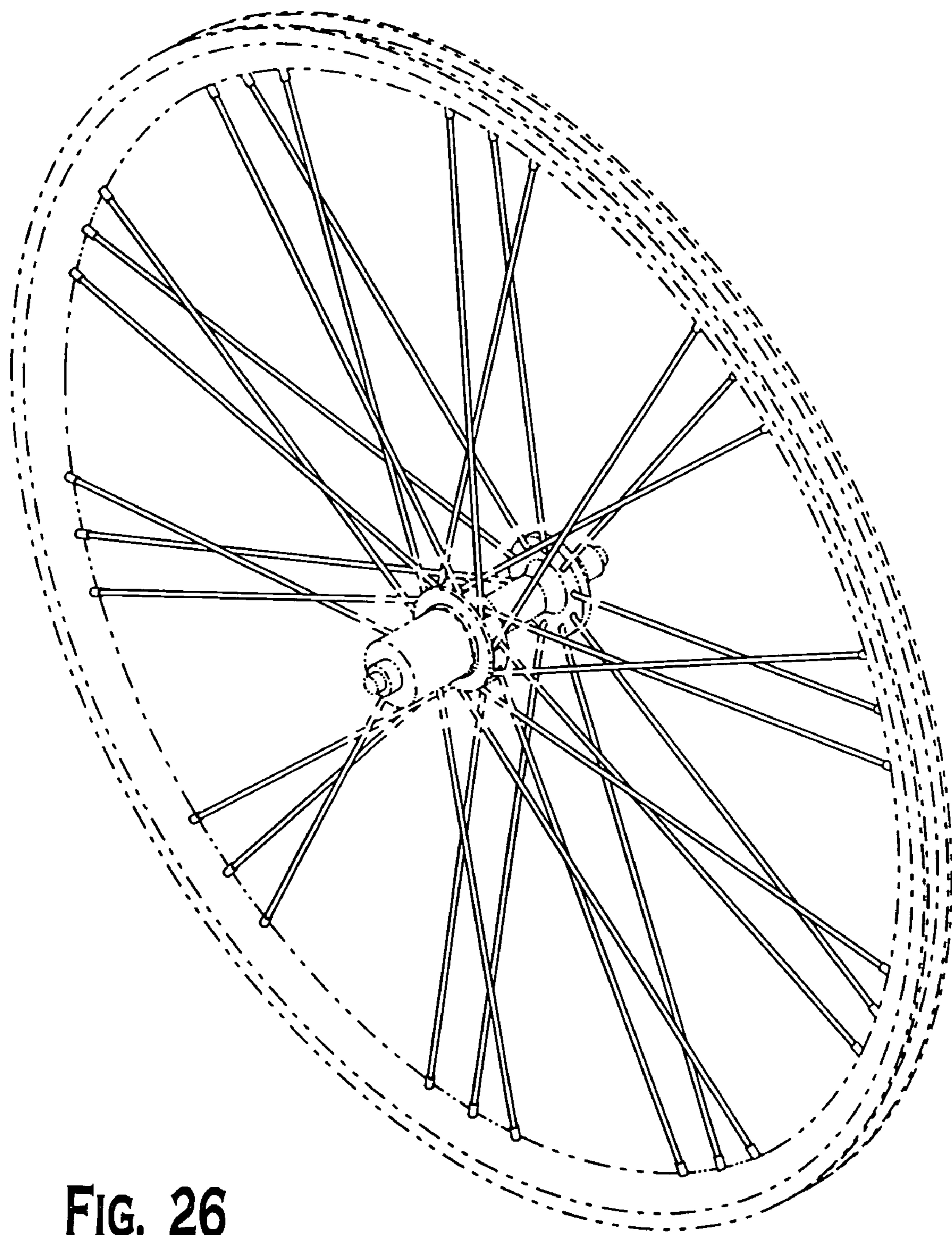

FIG. 26

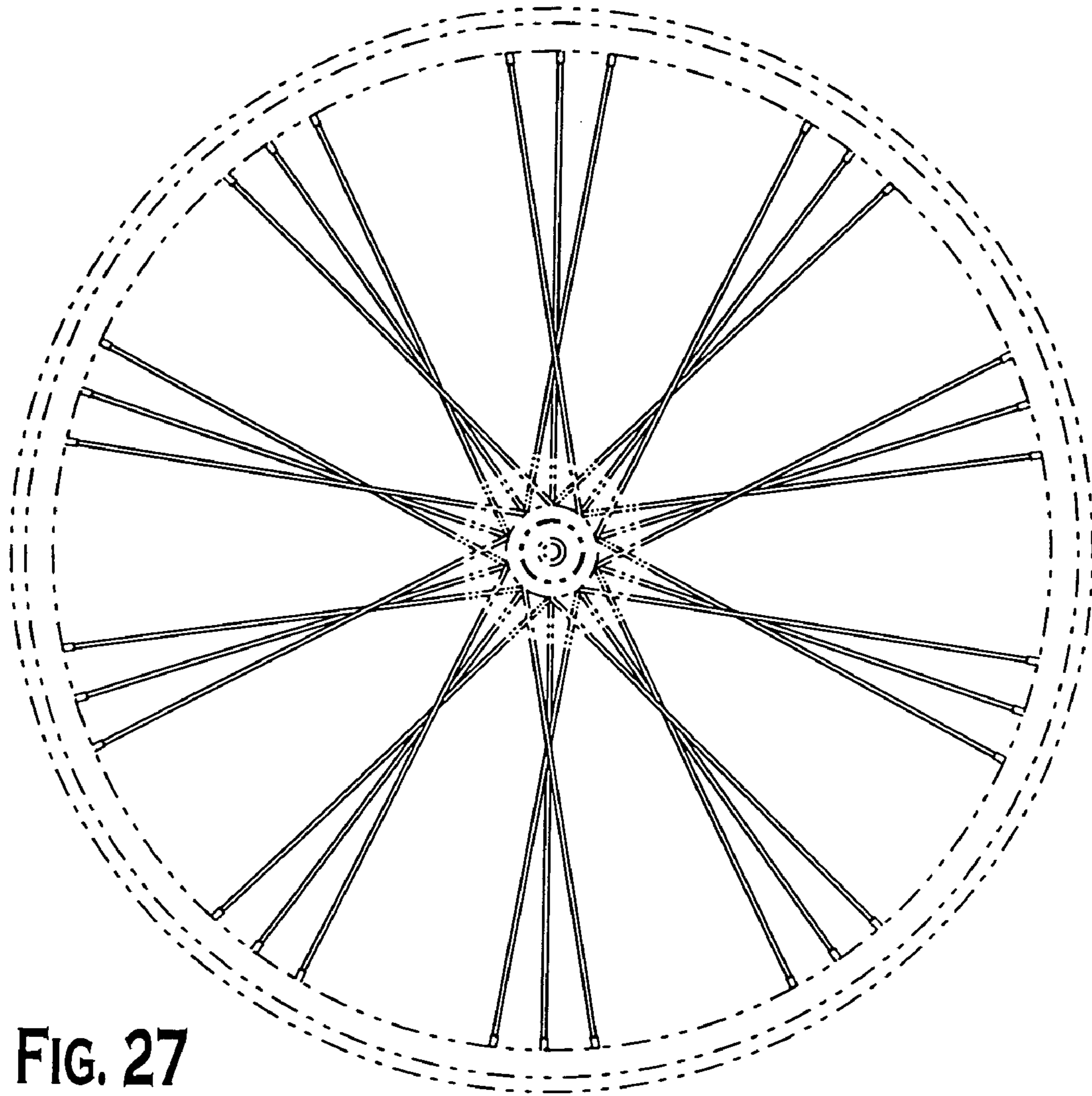

FIG. 27

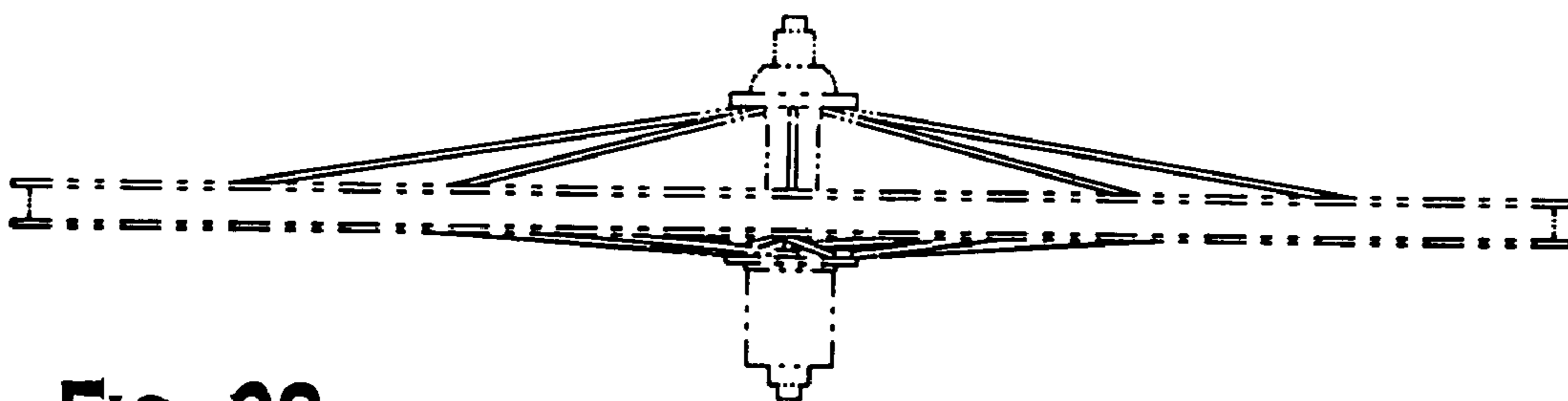

FIG. 28

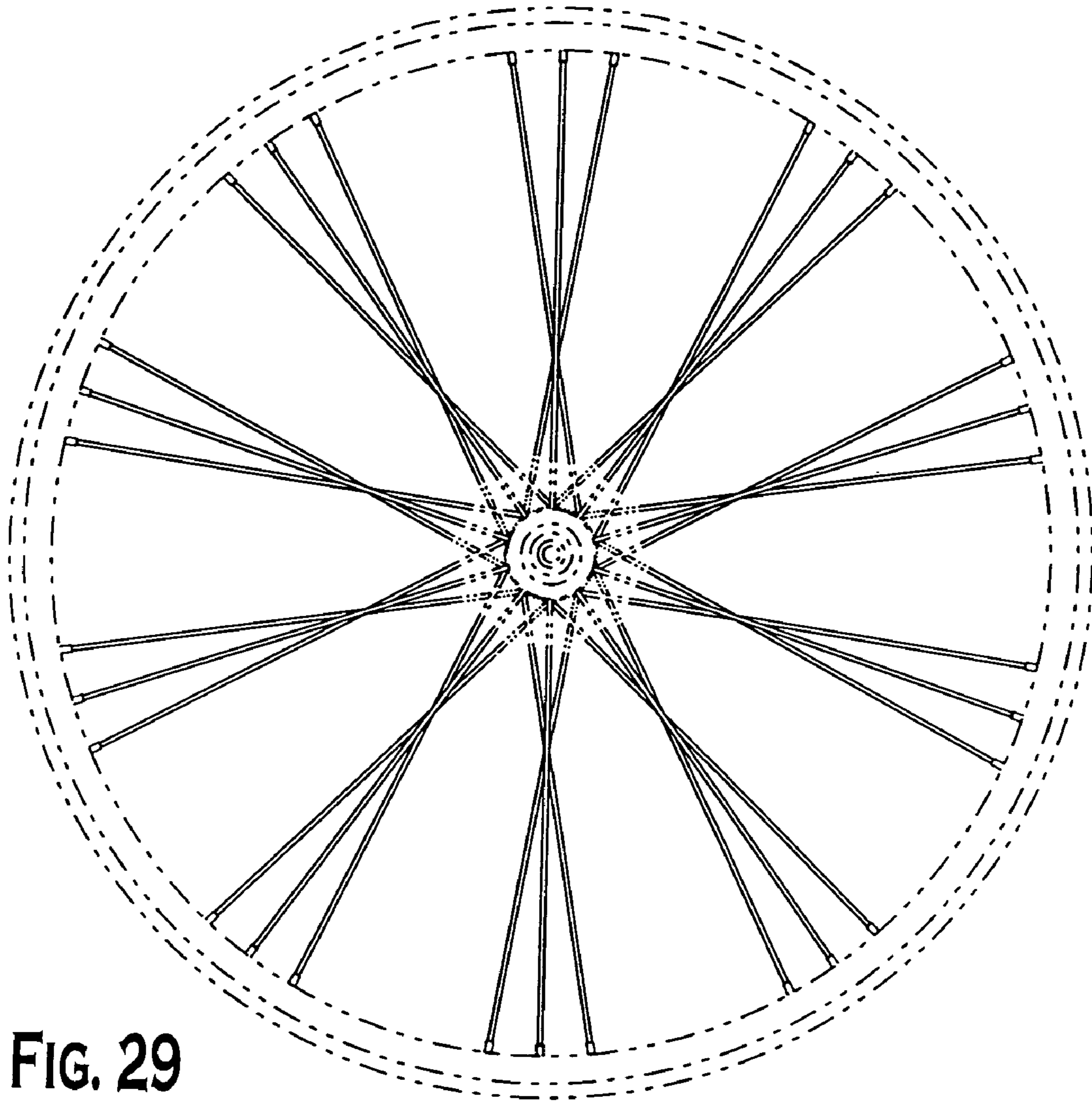

FIG. 29

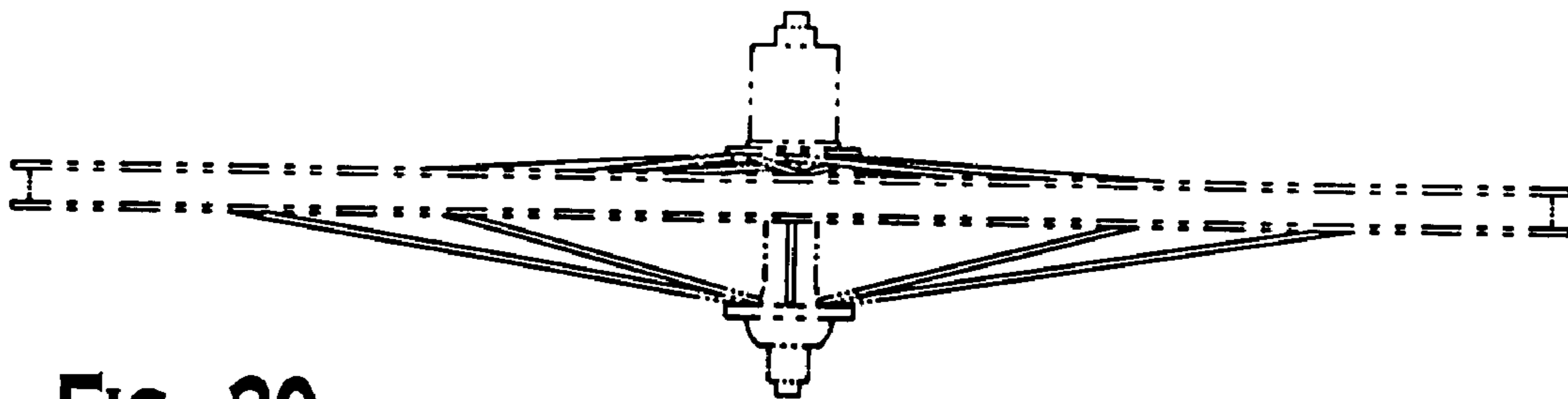

FIG. 30

UNITED STATES PATENT AND TRADEMARK OFFICE
CERTIFICATE OF CORRECTION

PATENT NO. : Des. 596,547 S
APPLICATION NO. : 29/190273
DATED : July 21, 2009
INVENTOR(S) : Passarotto et al.

Page 1 of 1

It is certified that error appears in the above-identified patent and that said Letters Patent is hereby corrected as shown below:

Title page in the claim, after the words “design for a”, delete “wheel of a bicycle”, and insert therefor
--Spoke Arrangement for a Wheel of a Bicycle--.

Signed and Sealed this

Sixth Day of April, 2010

A handwritten signature in black ink that reads "David J. Kappos". The signature is written in a cursive style with a large initial 'D' and a stylized 'K'.

David J. Kappos
Director of the United States Patent and Trademark Office