



US00D596412S

(12) **United States Design Patent**
Kim

(10) **Patent No.:** **US D596,412 S**

(45) **Date of Patent:** **** Jul. 21, 2009**

(54) **INFANT TRAVEL CHAIR**

5,826,287 A * 10/1998 Tandrup 5/655
D433,540 S * 11/2000 Safaie-Brown D29/101.4
D586,049 S * 2/2009 Boardman D29/101.1

(76) Inventor: **Noriko Mori Kim**, 3747 Aries Glen,
Escondido, CA (US) 92025

* cited by examiner

(**) Term: **14 Years**

Primary Examiner—Sandra Snapp

(21) Appl. No.: **29/331,028**

(74) *Attorney, Agent, or Firm*—Tracy P Jong

(22) Filed: **Jan. 17, 2009**

(57) **CLAIM**

(51) **LOC (9) Cl.** **06-01**

The ornamental design for an infant travel chair, as shown and described.

(52) **U.S. Cl.** **D6/333**

(58) **Field of Classification Search** D6/333,
D6/335, 339, 491, 500–502; D12/129; D21/412,
D21/419; 280/30, 31; 5/94, 98.1, 99.1, 101,
5/102, 105, 655; 297/183.1, 183.2, 183.3,
297/183.4, 184.13, 184.15, 184.17, 250.1,
297/255, 256.1, 256.15, 256.16

DESCRIPTION

See application file for complete search history.

FIG. 1 is a front perspective view of a infant travel chair as depicted in use with an infant and chair;

(56) **References Cited**

U.S. PATENT DOCUMENTS

3,136,581 A * 6/1964 Caballero 297/465
D240,567 S * 7/1976 Tatum D3/214
D248,426 S * 7/1978 Hill et al. D6/333
4,235,474 A * 11/1980 Rosenberg 297/465
4,702,523 A * 10/1987 Schrader et al. 297/485
D292,653 S * 11/1987 Church et al. D6/333
4,834,459 A * 5/1989 Leach 297/467
4,871,210 A * 10/1989 Alexander et al. 297/485
5,042,878 A * 8/1991 Collins 297/467
D342,615 S * 12/1993 Asher D6/333
D343,958 S * 2/1994 Greenwood D6/333
5,460,430 A * 10/1995 Miga et al. 297/452.13
5,503,458 A * 4/1996 Petrie 297/452.13

FIG. 2 is a front elevational view of an infant travel chair showing the design, the infant travel chair shown in an alternate position than that shown in FIG. 1;

FIG. 3 is a rear elevational view from the top thereof;

FIG. 4 is a top plan view as depicted in use with an infant and chair;

FIG. 5 is a left rear elevational view as depicted in use with a chair in the untied position; and,

FIG. 6 is a rear elevational plan as depicted in use with a chair in the tied position.

The broken lines shown in the drawings are understood to represent stitching. The dash-dot lines shown in the drawings are for illustrative purposes only and form no part of the claimed design. The cross-hatched areas are understood to encompass the entire associated area.

1 Claim, 6 Drawing Sheets

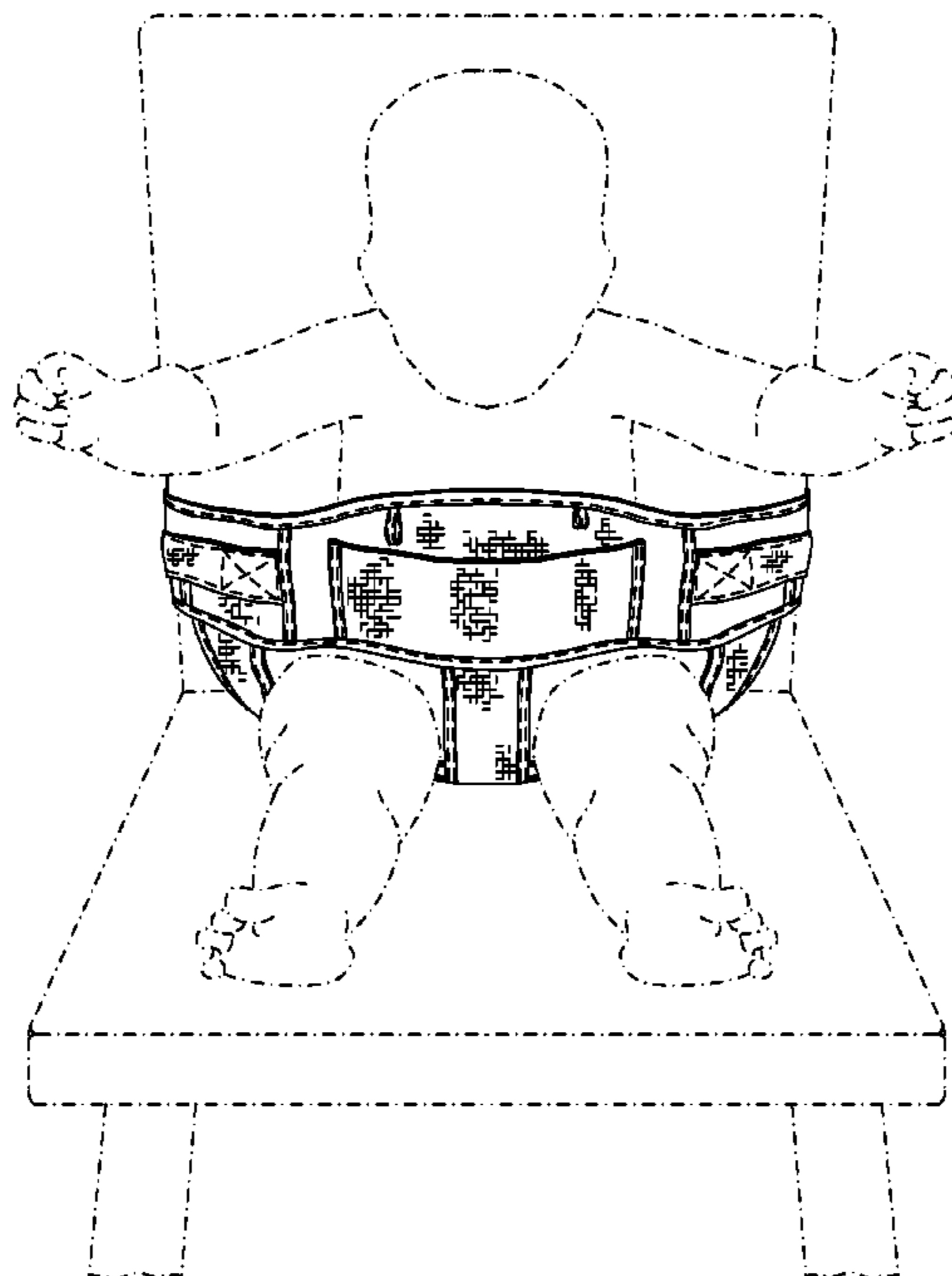

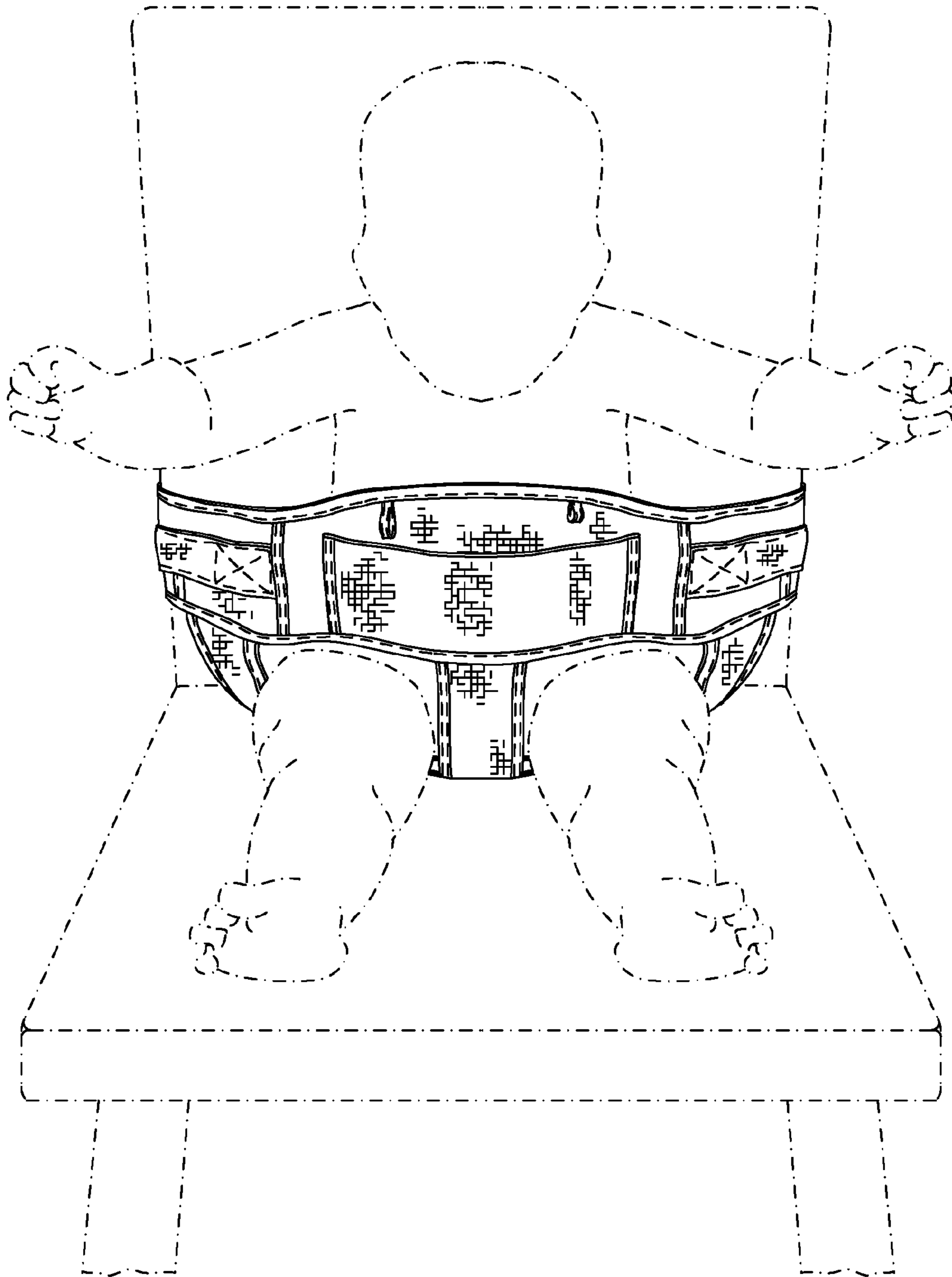
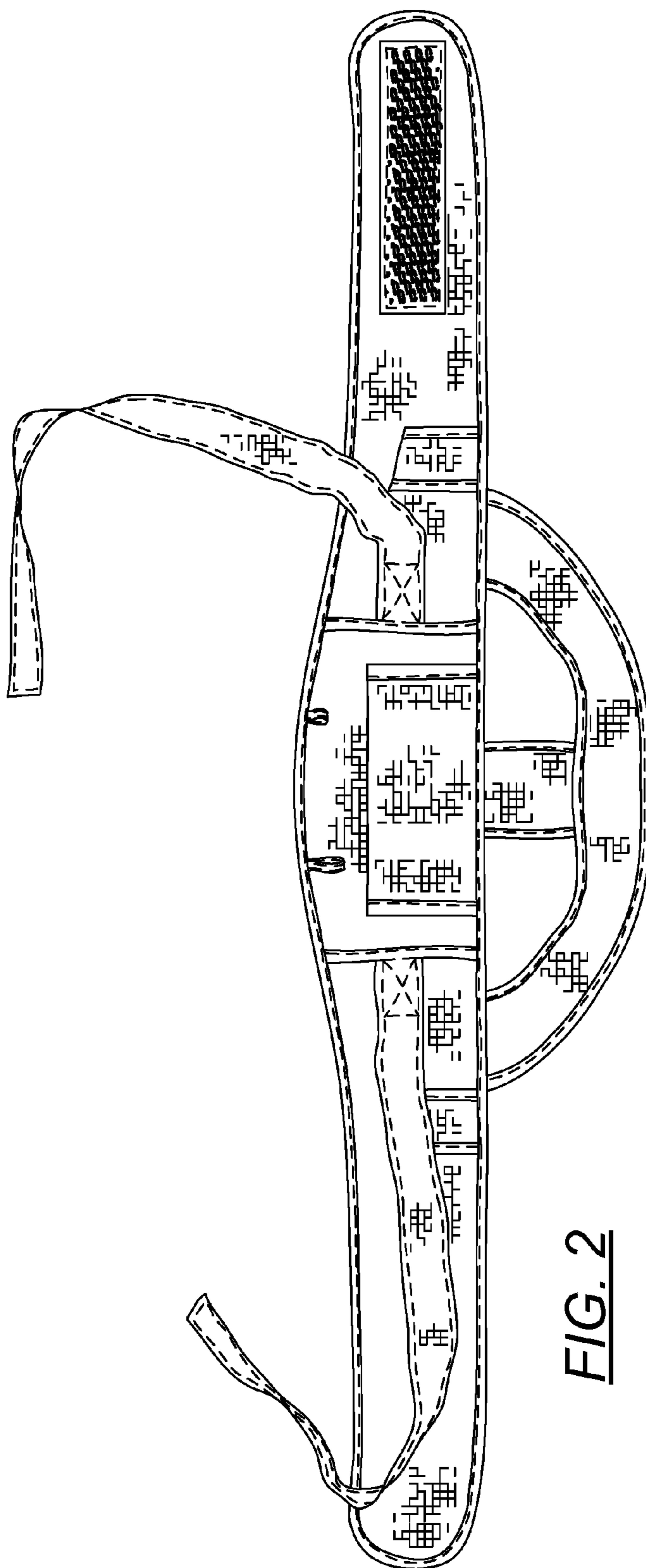

FIG. 1



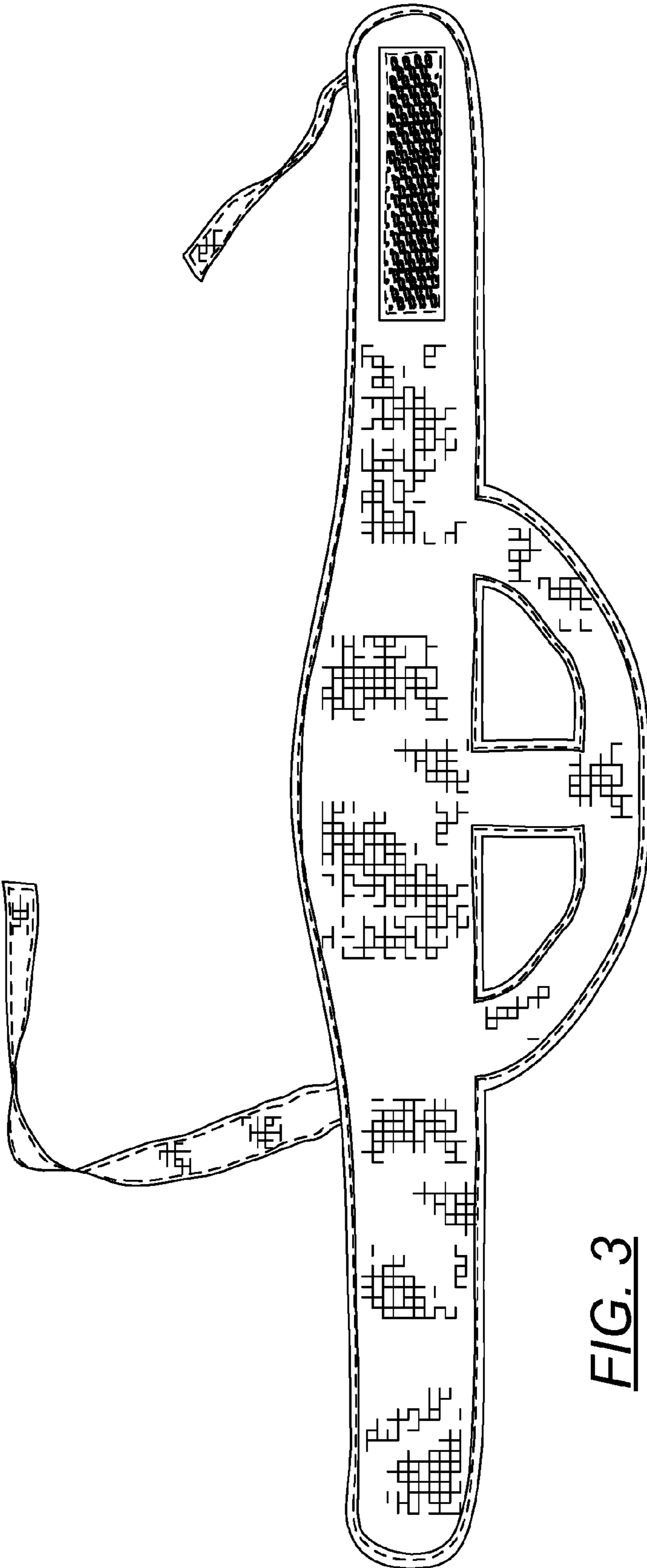

FIG. 3

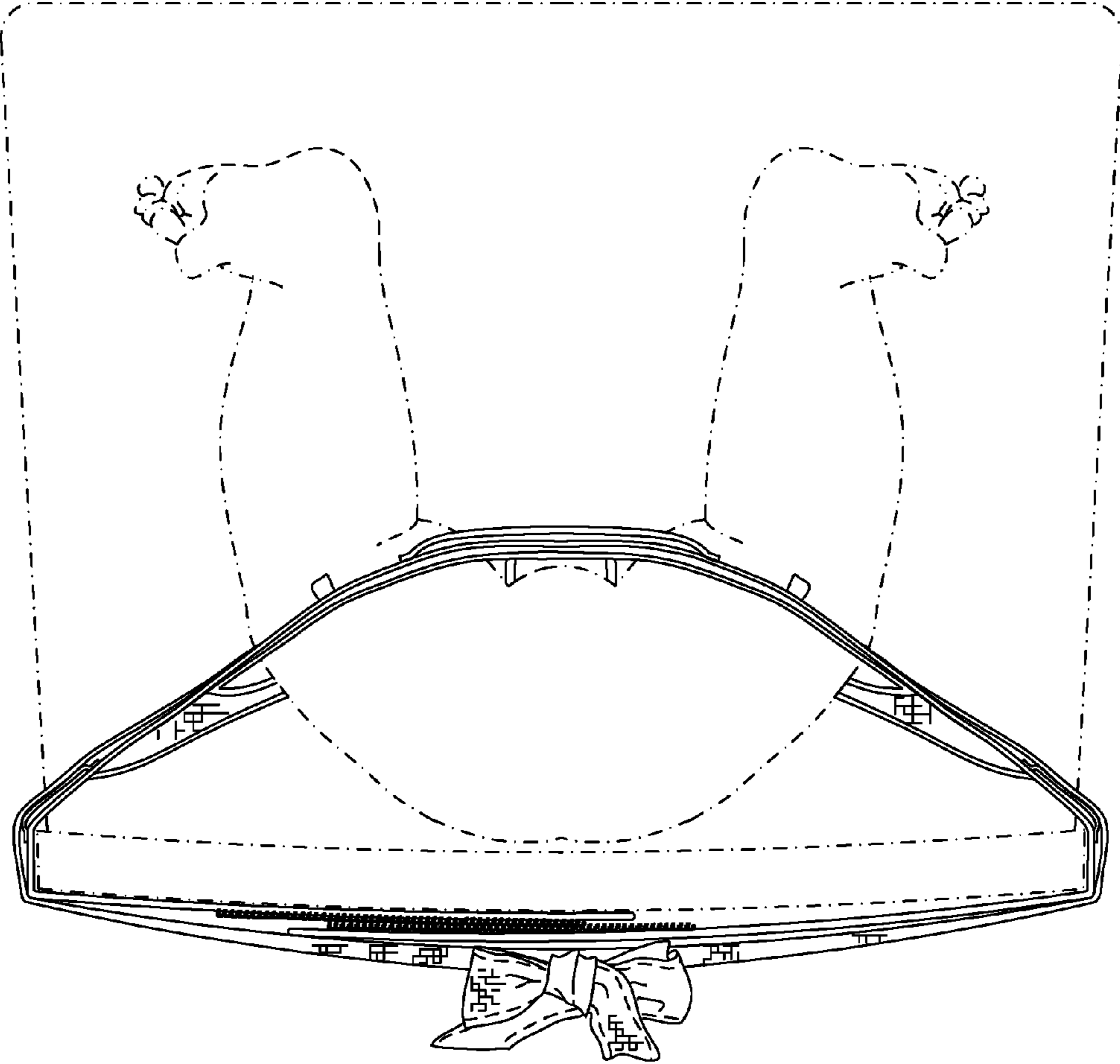

FIG. 4

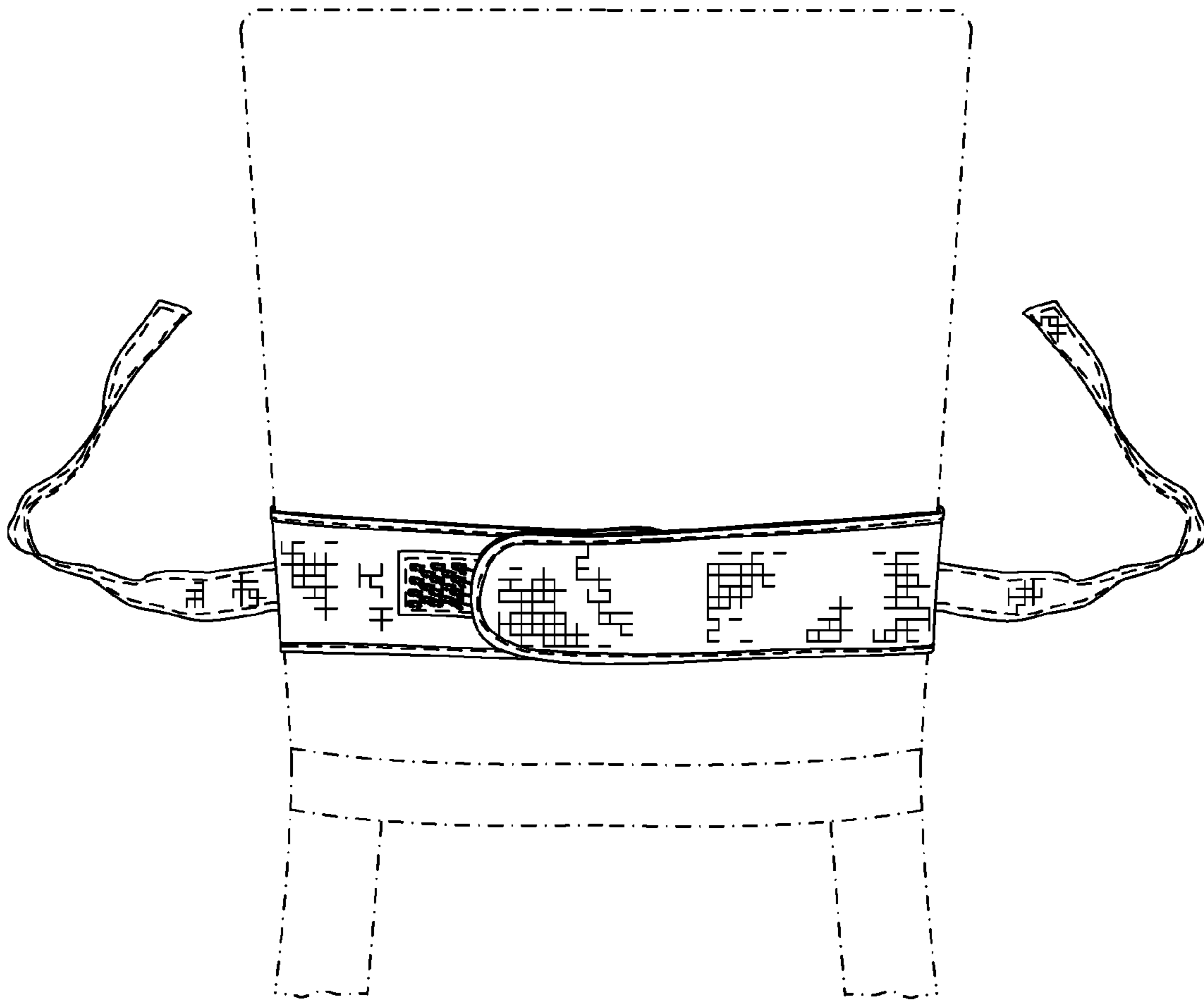

FIG. 5

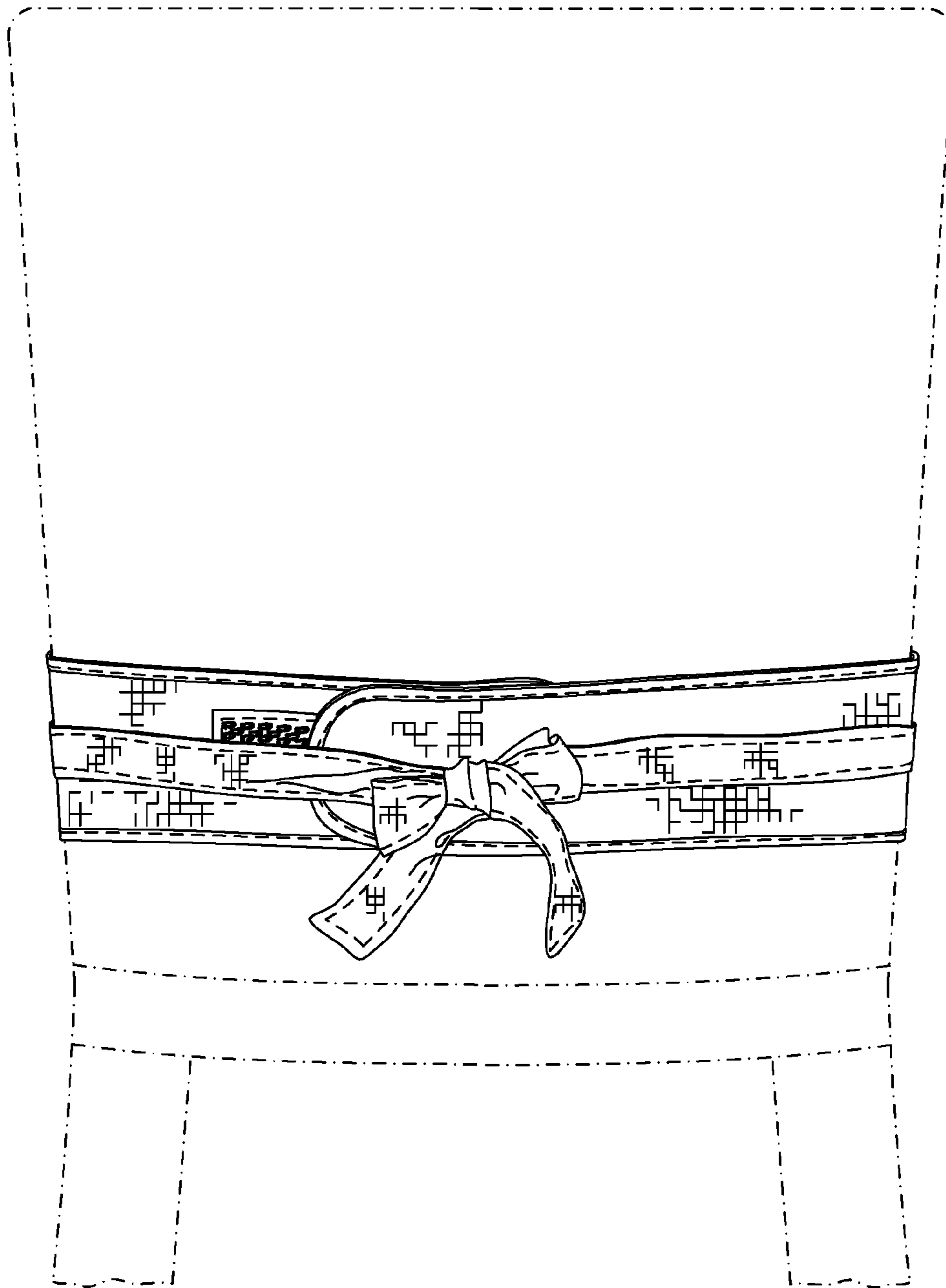

FIG. 6