



US00D596219S

(12) **United States Design Patent**  
**Tatara et al.**

(10) **Patent No.:** **US D596,219 S**  
(45) **Date of Patent:** **\*\* Jul. 14, 2009**

(54) **SCREEN UNIT FOR PROJECTOR**

(75) Inventors: **Yoshihiro Tatara**, Matsumoto (JP);  
**Kiyoshi Kuroi**, Matsumoto (JP)

(73) Assignee: **Seiko Epson Corporation**, Tokyo (JP)

(\*\*) Term: **14 Years**

(21) Appl. No.: **29/329,064**

(22) Filed: **Dec. 8, 2008**

(30) **Foreign Application Priority Data**

Sep. 11, 2008 (JP) ..... 2008-023343

(51) **LOC (9) Cl.** ..... **16-05**

(52) **U.S. Cl.** ..... **D16/241**

(58) **Field of Classification Search** ..... D16/235,  
D16/241-242, 245, 250; D20/10; 396/3-4;  
160/24, 37-38, 351; 359/443, 461, 459,  
359/460; 362/319-320, 352

See application file for complete search history.

(56) **References Cited**

**U.S. PATENT DOCUMENTS**

1,915,944 A \* 6/1933 Nagel ..... 160/24  
RE26,156 E \* 2/1967 Muller ..... 160/24  
D366,055 S \* 1/1996 Matsunaga et al. .... D16/241  
D490,835 S \* 6/2004 Kotera ..... D16/241  
6,771,232 B2 \* 8/2004 Fujieda et al. .... 345/30  
6,873,458 B1 \* 3/2005 Bakkom et al. .... 359/443  
7,203,000 B2 \* 4/2007 Kotera ..... 359/461

D548,765 S \* 8/2007 Kotera et al. .... D16/241  
7,463,238 B2 \* 12/2008 Funkhouser et al. .... 345/107  
2006/0279840 A1 \* 12/2006 Yamauchi ..... 359/461

\* cited by examiner

*Primary Examiner*—Ian Simmons

*Assistant Examiner*—Wan Laymon

(74) *Attorney, Agent, or Firm*—Oliff & Berridge PLC

(57) **CLAIM**

The ornamental design for a screen unit for projector, as shown and described.

**DESCRIPTION**

FIG. 1 is a front perspective view of a screen unit for projector in an open position;

FIG. 2 is a rear perspective view thereof;

FIG. 3 is a front view thereof;

FIG. 4 is a rear view thereof;

FIG. 5 is a left side view thereof;

FIG. 6 is a right side view thereof;

FIG. 7 is a top view thereof;

FIG. 8 is a bottom view thereof; and,

FIG. 9 is a front perspective view of the screen unit for projector in a closed position.

The broken lines depict environmental subject matter only and form no part of the claimed design.

**1 Claim, 7 Drawing Sheets**

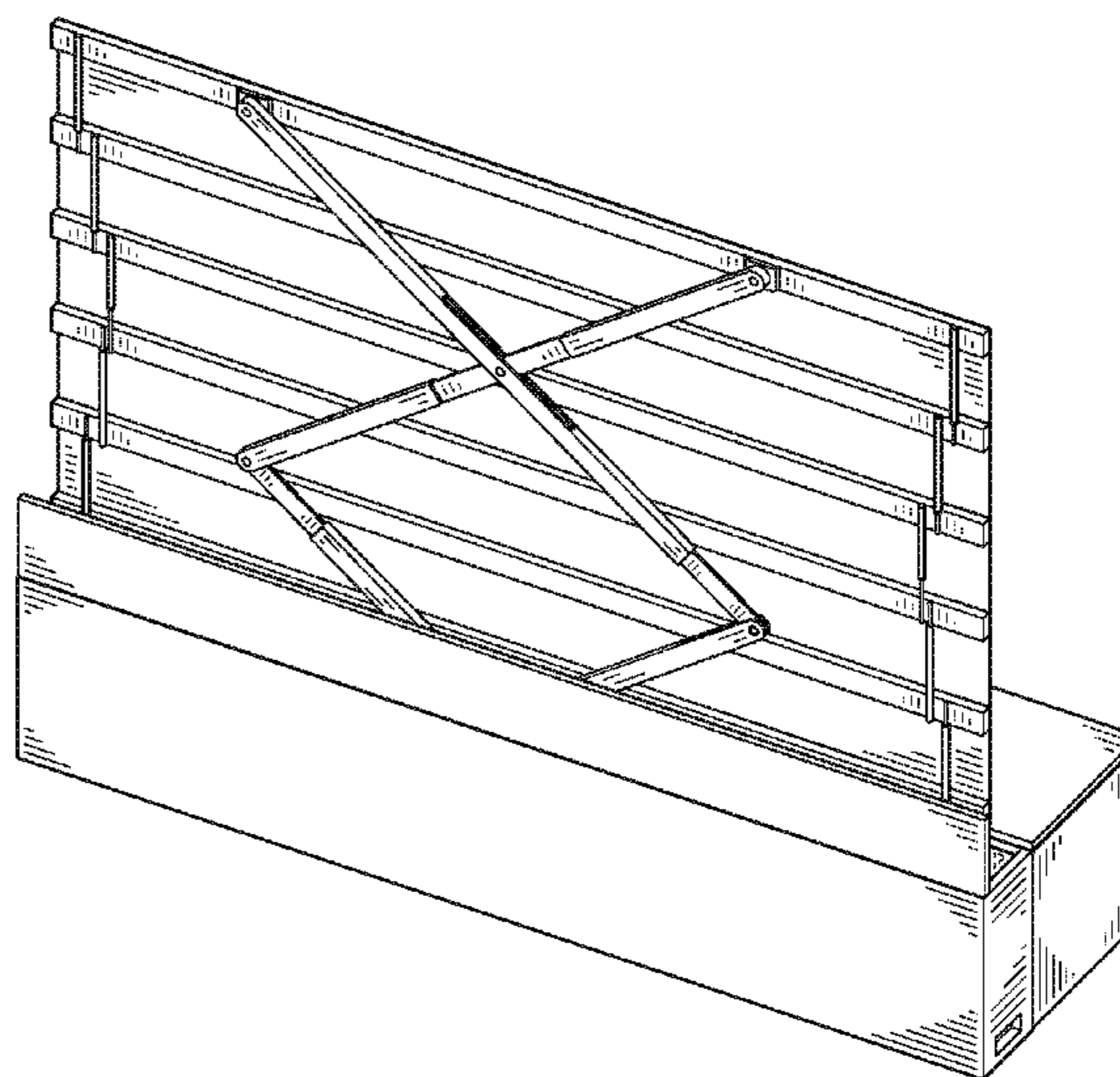
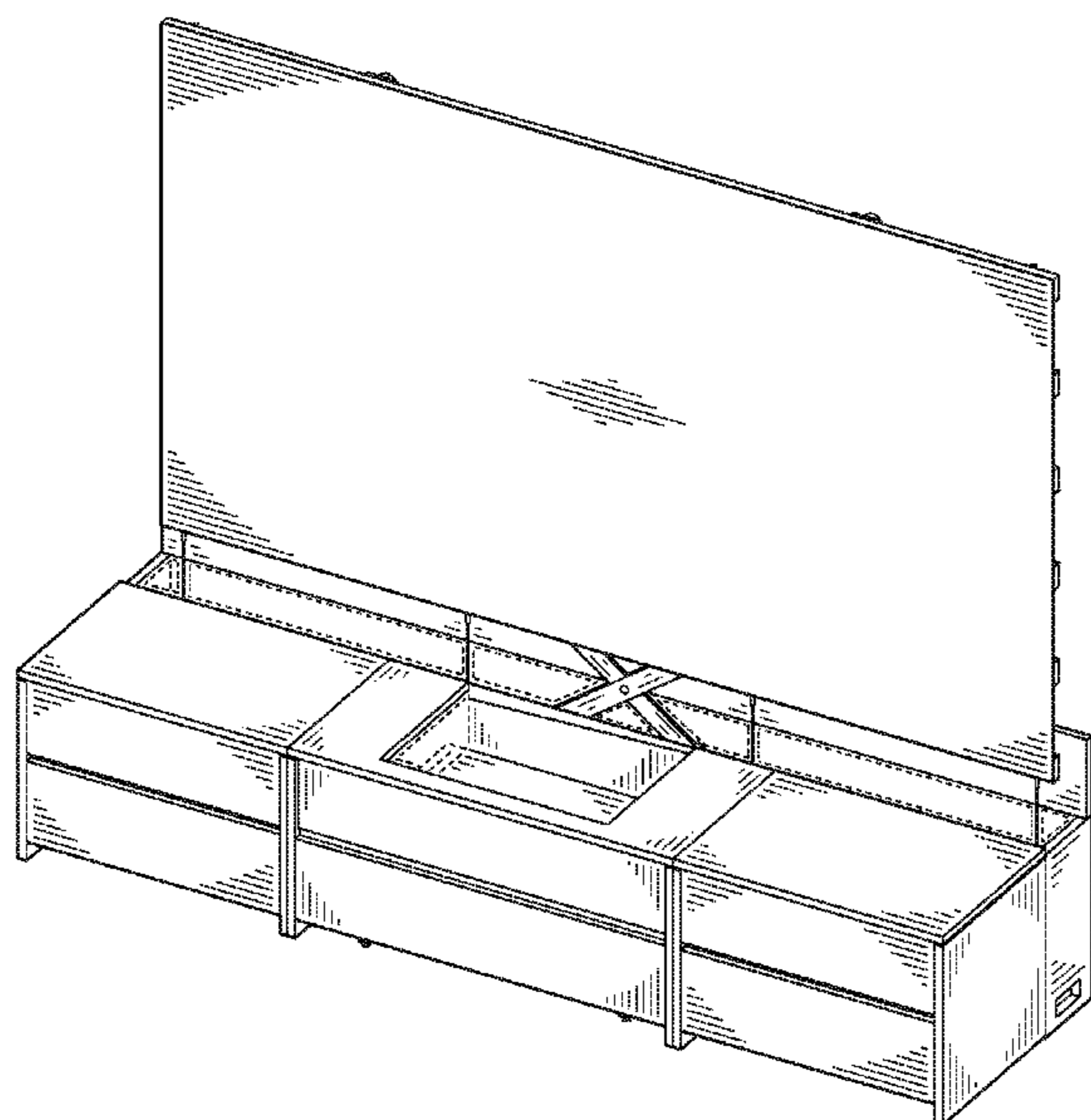

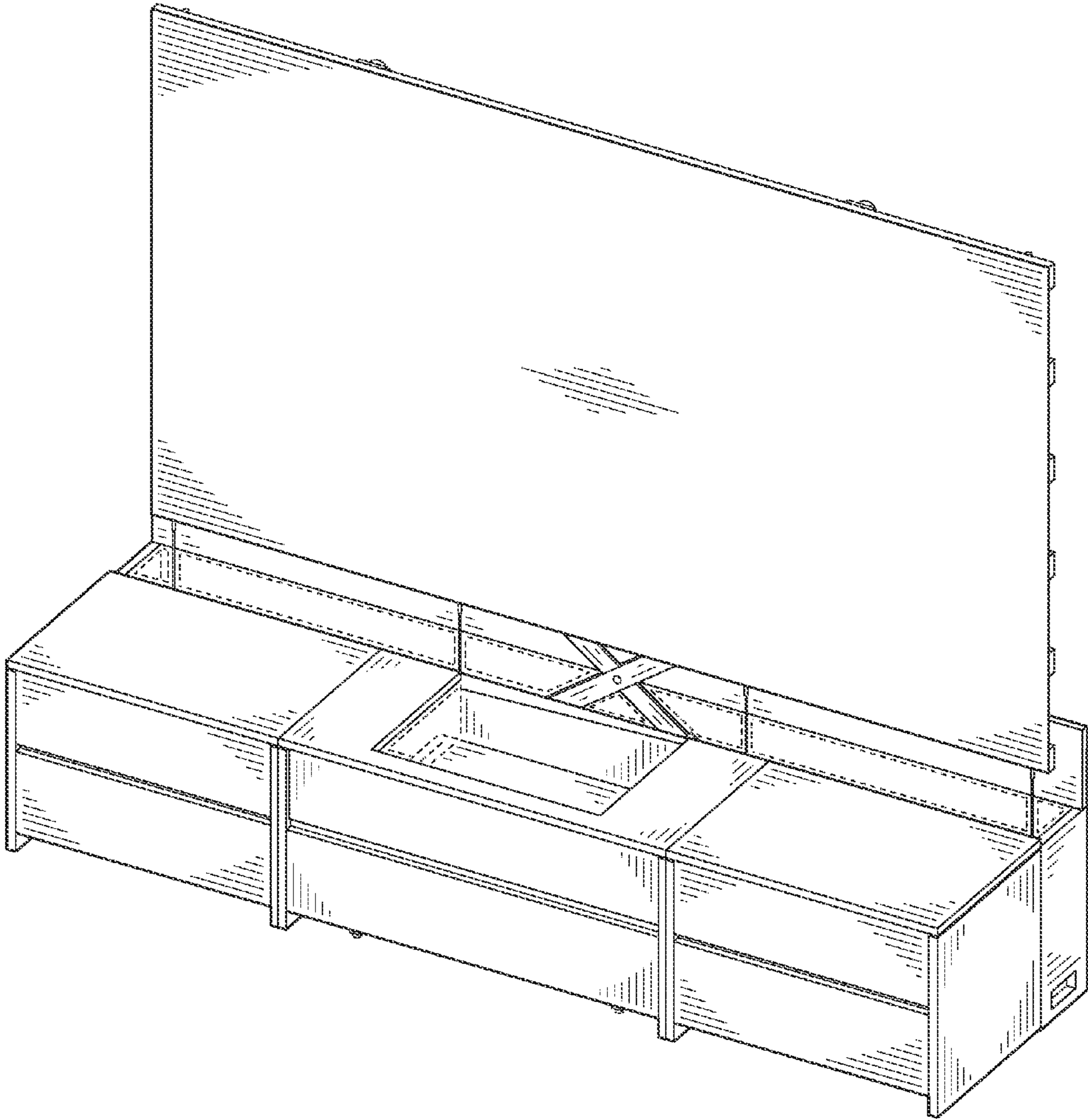

FIG. 1

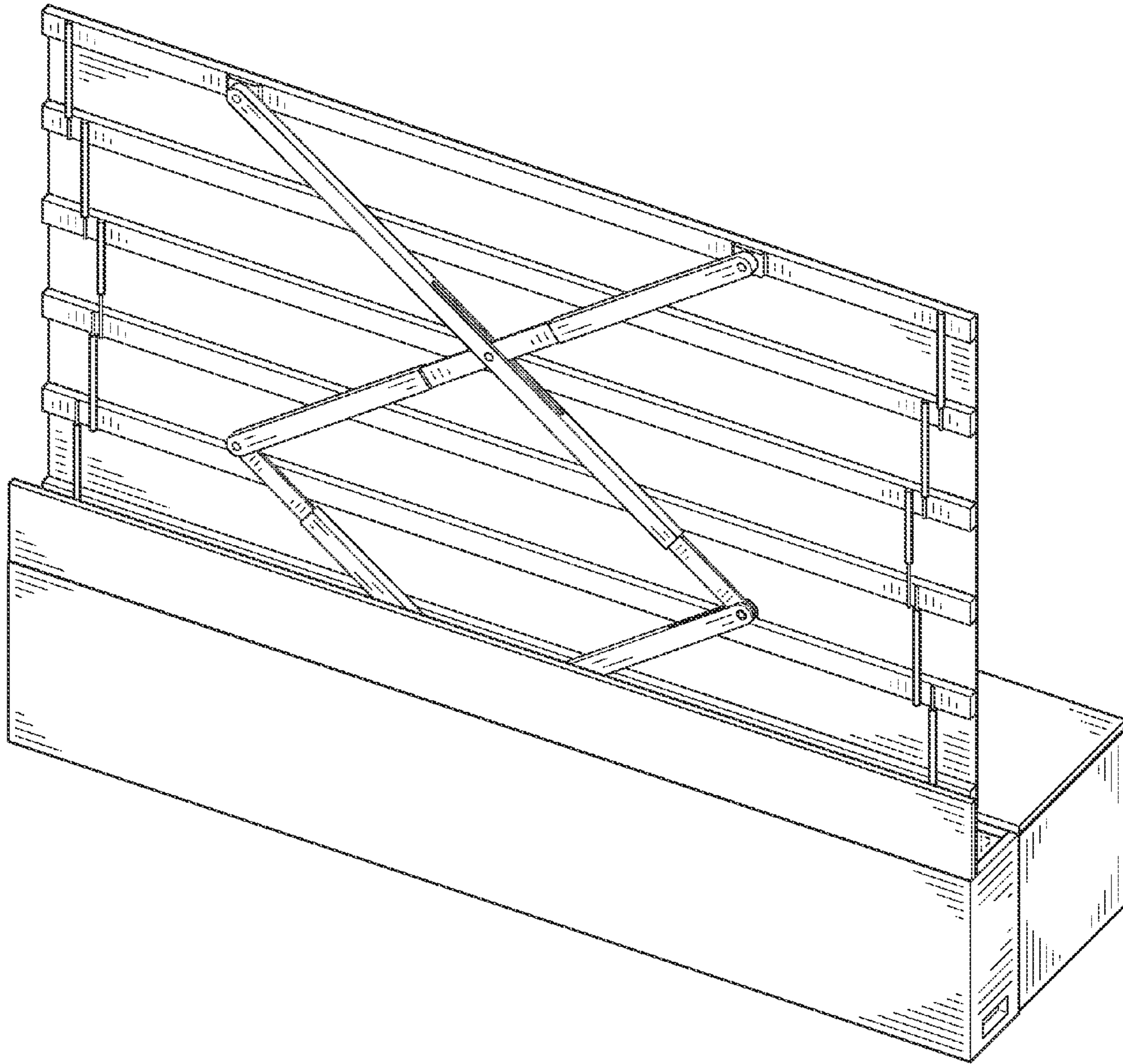

FIG. 2

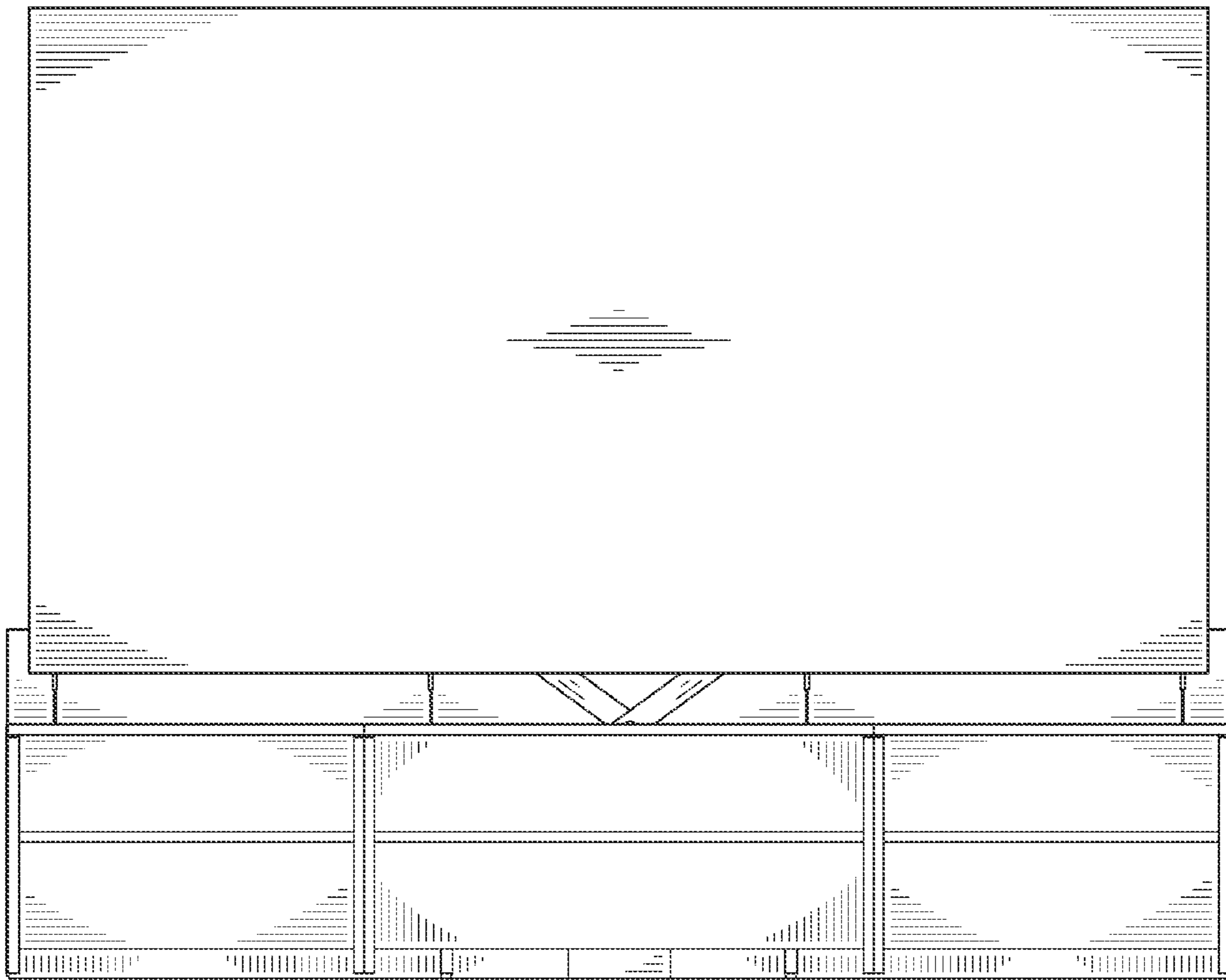

FIG. 3

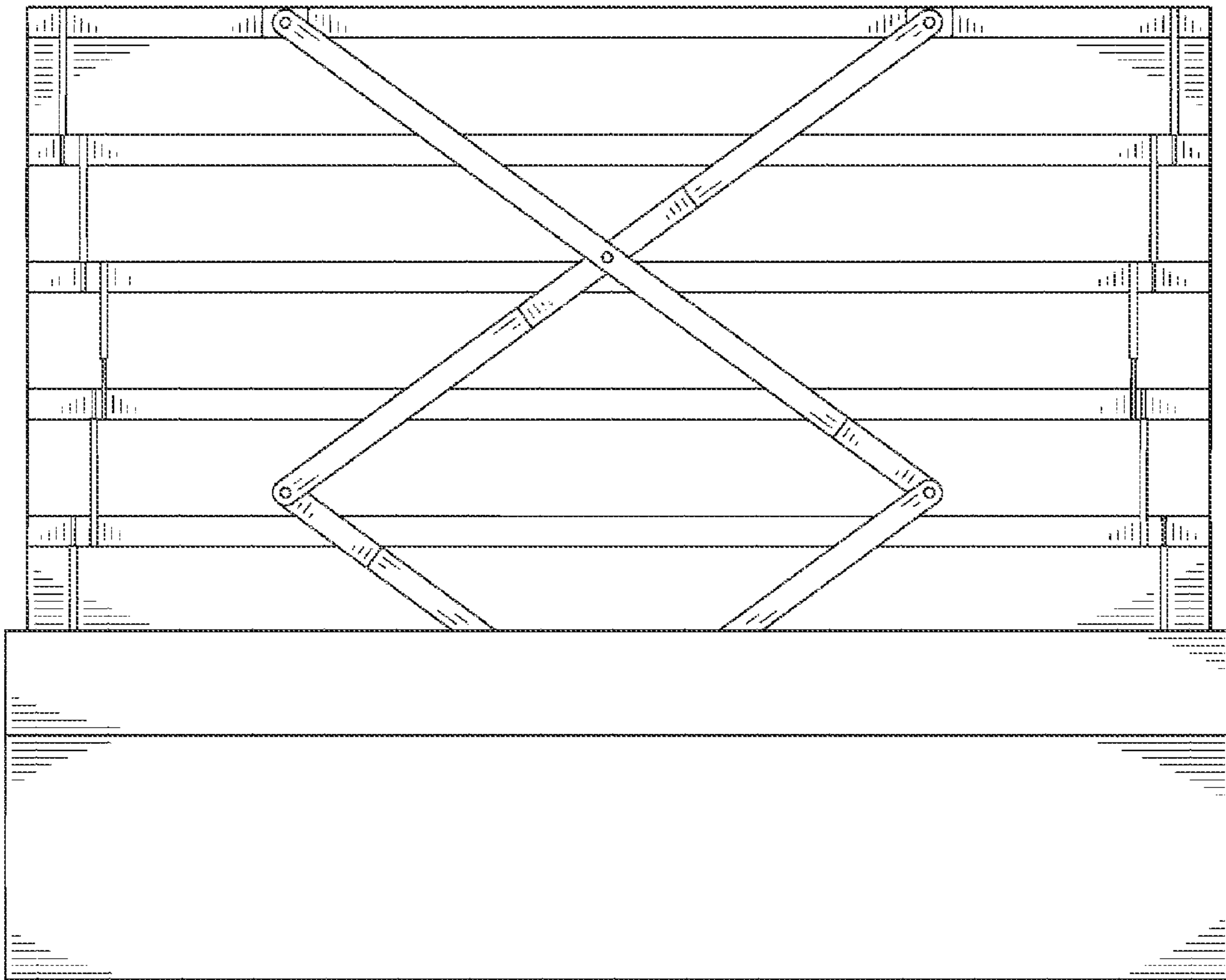

FIG. 4

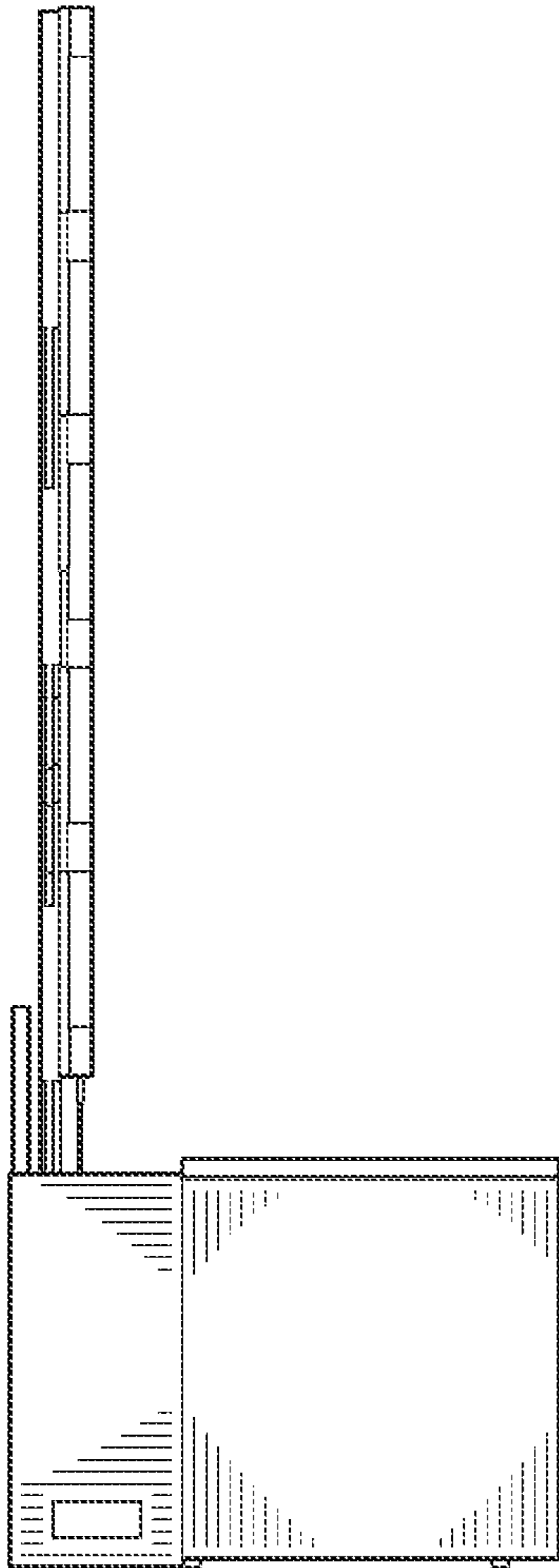

FIG. 5

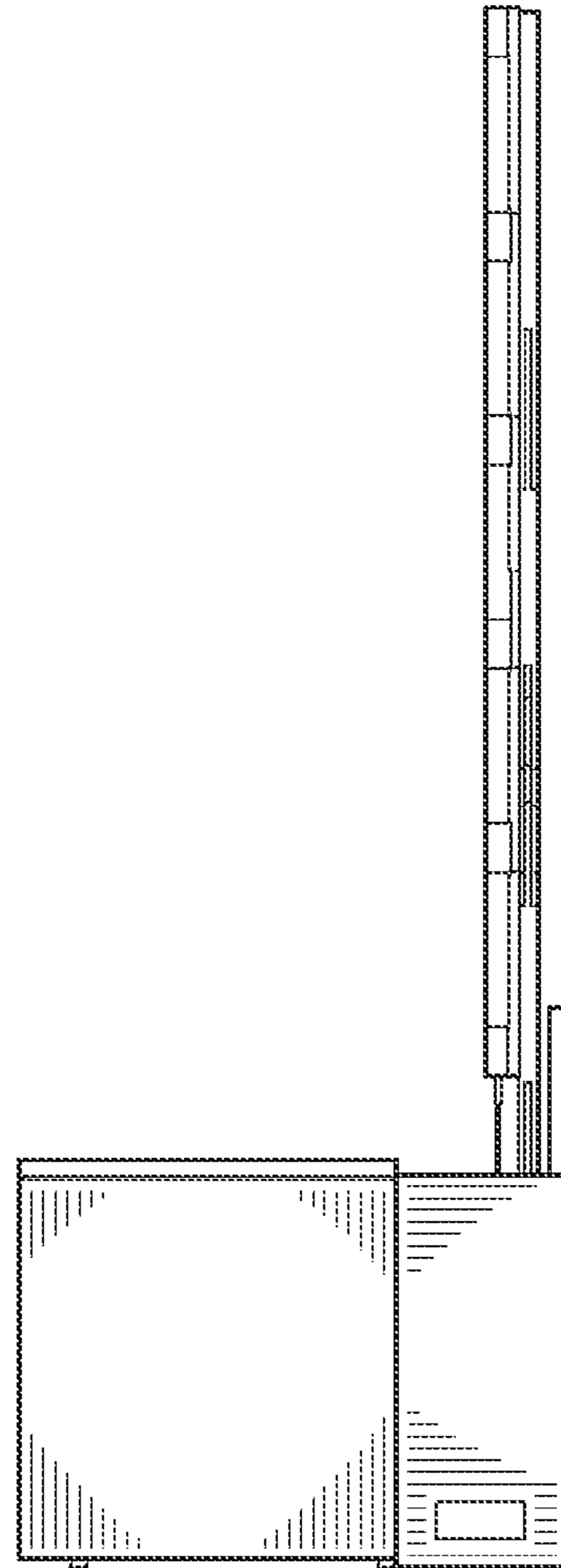

FIG. 6

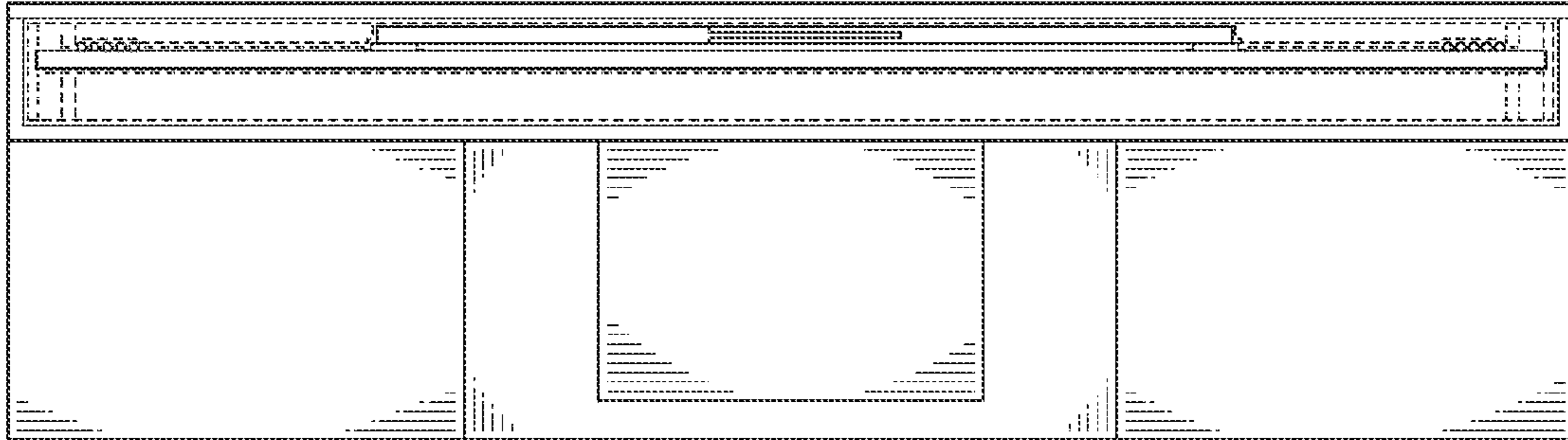

FIG. 7

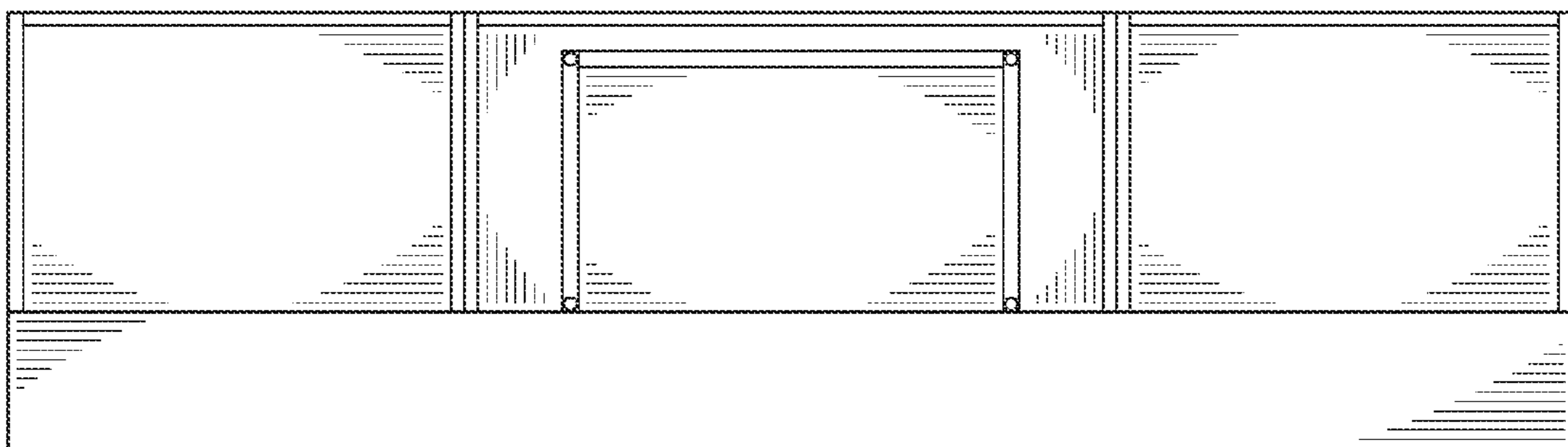

FIG. 8

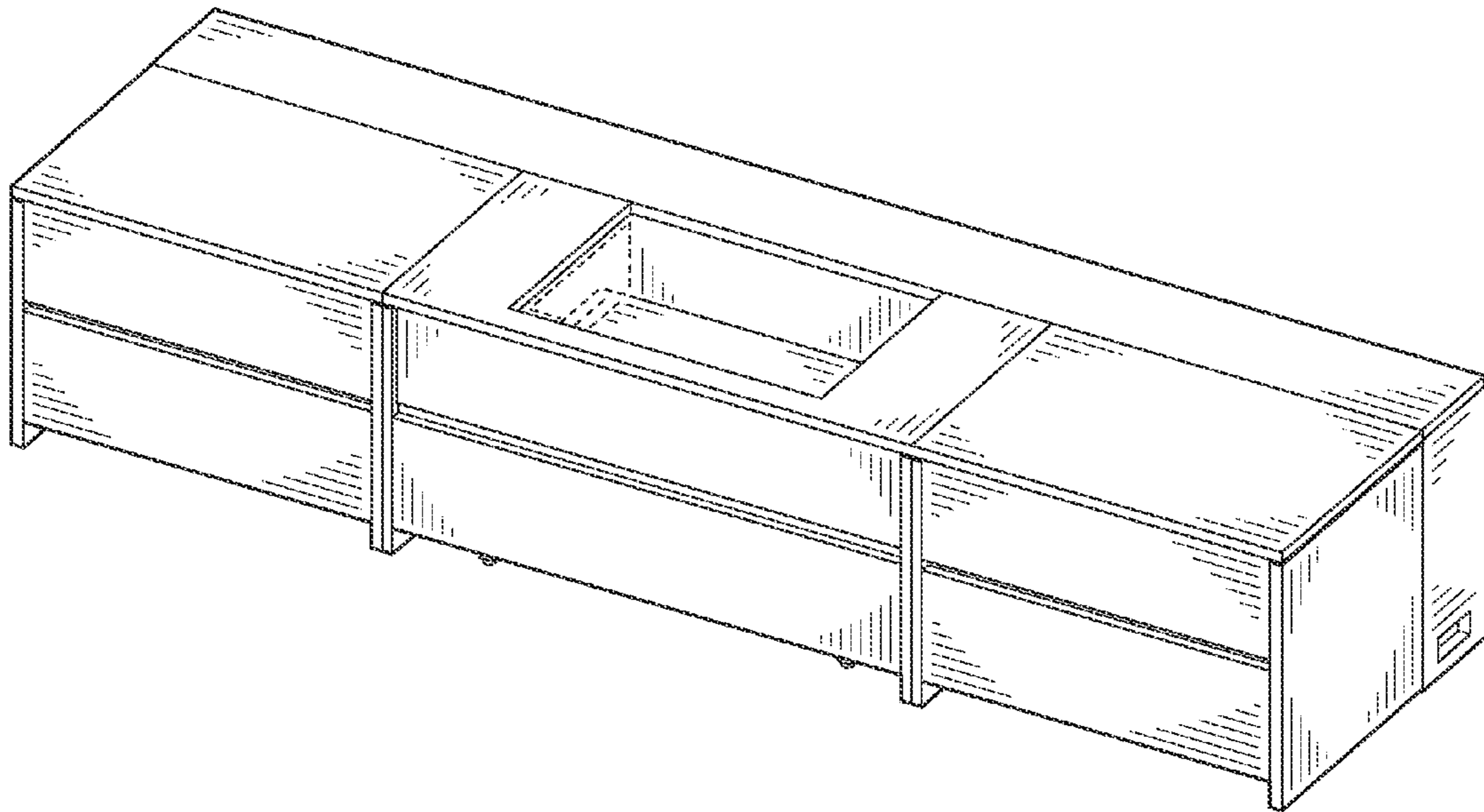

FIG. 9