

US00D596077S

(12) **United States Design Patent**
Bryant et al.

(10) **Patent No.:** **US D596,077 S**
(45) **Date of Patent:** **** Jul. 14, 2009**

(54) **PORTION OF AN OFF-HIGHWAY TRUCK**

(75) Inventors: **Gary C. Bryant**, Chillicothe, IL (US);
Michael J. Vance, Suhuarita, AZ (US);
Brian S. Underwood, Monticello, IL
(US); **Ryan D. Looper**, Mt. Zion, IL
(US); **Clifford E. Miller**, Marseilles, IL
(US); **Jared L. Becker**, Taylorville, IL
(US); **Timothy J. Bromenshenkel**,
Decatur, IL (US); **Stephen Bushong**,
Decatur, IL (US); **Brian R. Janes**,
Chillicothe, IL (US); **Kevin F. Stremmlau**,
Peoria, IL (US); **Colton T. Anderson**,
Chillicothe, IL (US); **John J. Maas**,
Mount Zion, IL (US); **Craig B. Kelley**,
Dunlap, IL (US)

(73) Assignee: **Caterpillar Inc.**, Peoria, IL (US)

(**) Term: **14 Years**

(21) Appl. No.: **29/285,532**

(22) Filed: **Mar. 30, 2007**

(51) **LOC (9) Cl.** **08-10**

(52) **U.S. Cl.** **D12/15**

(58) **Field of Classification Search** D12/1,
D12/5, 22, 15, 93, 98, 196, 14; D15/10,
D15/25, 30, 33; 414/245, 685, 688, 722,
414/724, 493; 108/234, 641; 37/403, 413,
37/442, 443, 412; D21/558, 559, 562, 561
See application file for complete search history.

(56) **References Cited**

U.S. PATENT DOCUMENTS

D101,926 S	11/1936	Tranaas	
D125,863 S	3/1941	Omon	
D184,217 S	1/1959	Eriacher et al.	
D204,604 S	5/1966	Fryer	
D217,726 S	6/1970	Cohn	
3,713,666 A	1/1973	Cheers et al.	
D234,130 S *	1/1975	Kress D12/15
D235,528 S	6/1975	Ahola	

3,923,337 A	12/1975	Kershaw et al.	
3,938,238 A	2/1976	Kershaw et al.	
D240,613 S *	7/1976	Thomas et al. D12/15
3,977,489 A *	8/1976	Cole et al. 180/89.1
4,236,601 A *	12/1980	Naka 182/76
4,307,300 A	12/1981	Kisami	
4,325,444 A	4/1982	Anami	
4,418,636 A	12/1983	Piper	
4,491,336 A	1/1985	Myers	
4,531,781 A *	7/1985	Hunt et al. 298/22 P

(Continued)

OTHER PUBLICATIONS

Rigid Dumper, RD 32, Astra, English 09-2005 (3 pps.).
New Rigid Dump Trucks, RD 28, RD 32, Astra Italian/English,
A3500679-05-2005, (2 pps.).

Primary Examiner—T. Chase Nelson
Assistant Examiner—Ania K Dworzecka
(74) *Attorney, Agent, or Firm*—Michael D. Braunstein

(57) **CLAIM**

The ornamental design for a portion of an off-highway truck,
as shown and described.

DESCRIPTION

FIG. 1 is a front view of our new design;
FIG. 2 is a left view thereof;
FIG. 3 is a rear view thereof;
FIG. 4 is a right view thereof;
FIG. 5 is a top view thereof;
FIG. 6 is a left, front perspective view thereof; and,
FIG. 7 is a right, front perspective view thereof.
The bottom view does not form part of the claimed design and
therefore is not disclosed.
The elements depicted in dashed lines form no part of the
ornamental design.

1 Claim, 7 Drawing Sheets

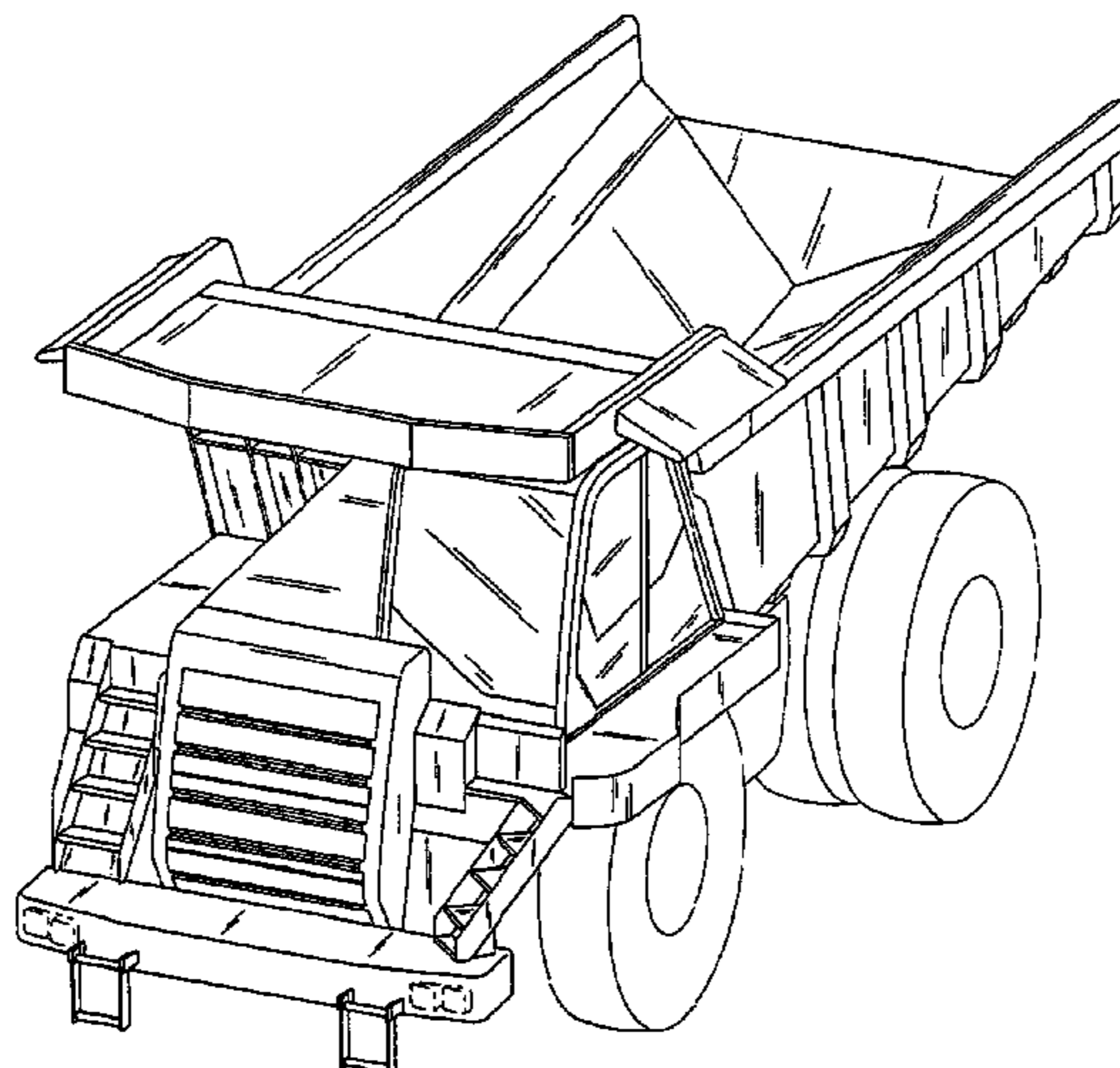

US D596,077 S

Page 2

U.S. PATENT DOCUMENTS

D289,069 S 3/1987 Ohno
D289,748 S 5/1987 Proeschl
4,719,361 A 1/1988 Brubaker
5,385,391 A 1/1995 Dickerson
5,472,062 A 12/1995 Nagai et al.
6,113,193 A 9/2000 Kunzeman

6,175,788 B1 1/2001 Hasegawa et al.
D458,943 S 6/2002 Briggs et al.
D465,499 S 11/2002 Briggs et al.
6,588,539 B2 7/2003 Hinton et al.
7,100,256 B2 9/2006 D'Amico et al.

* cited by examiner

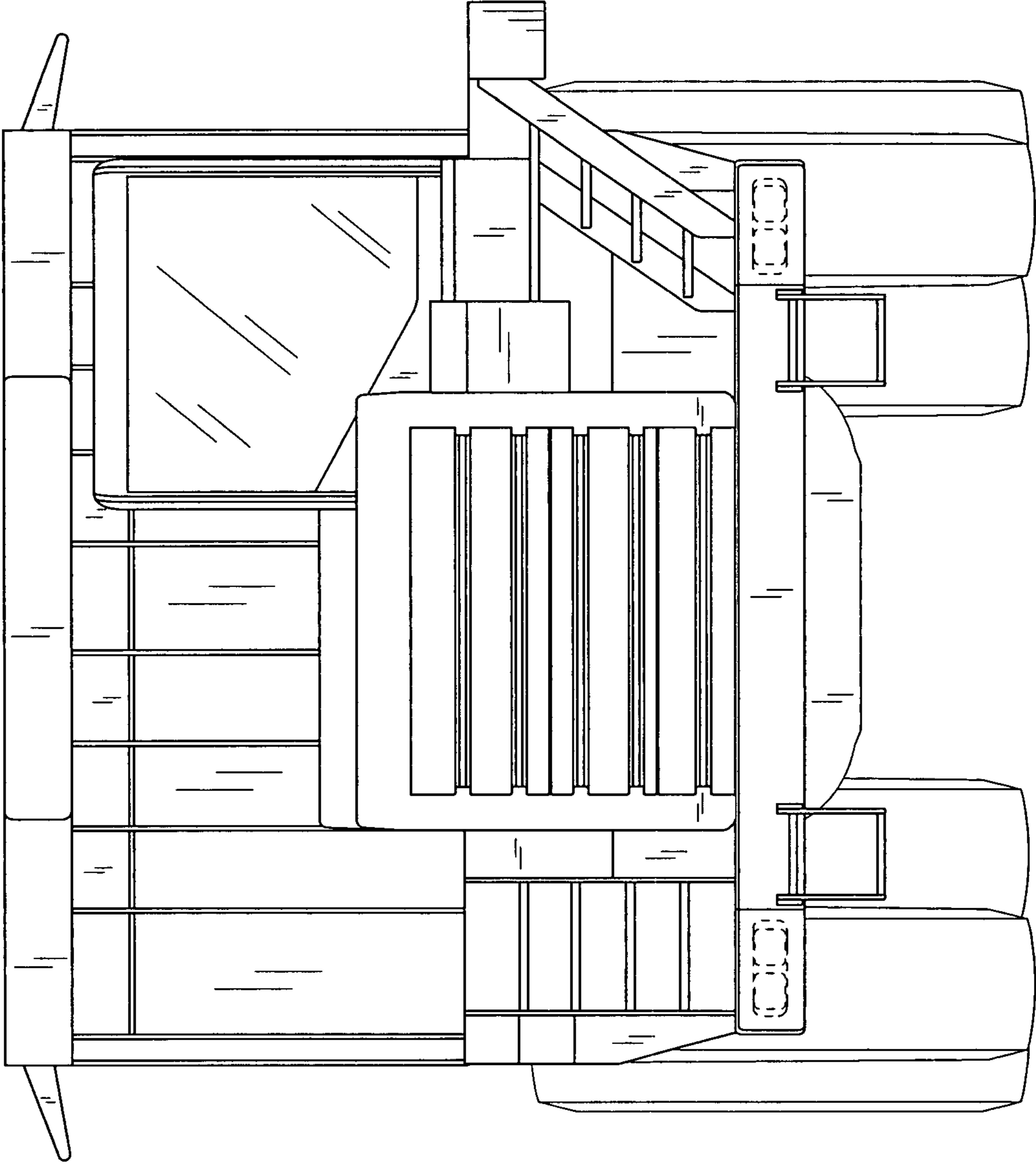

FIG. 1

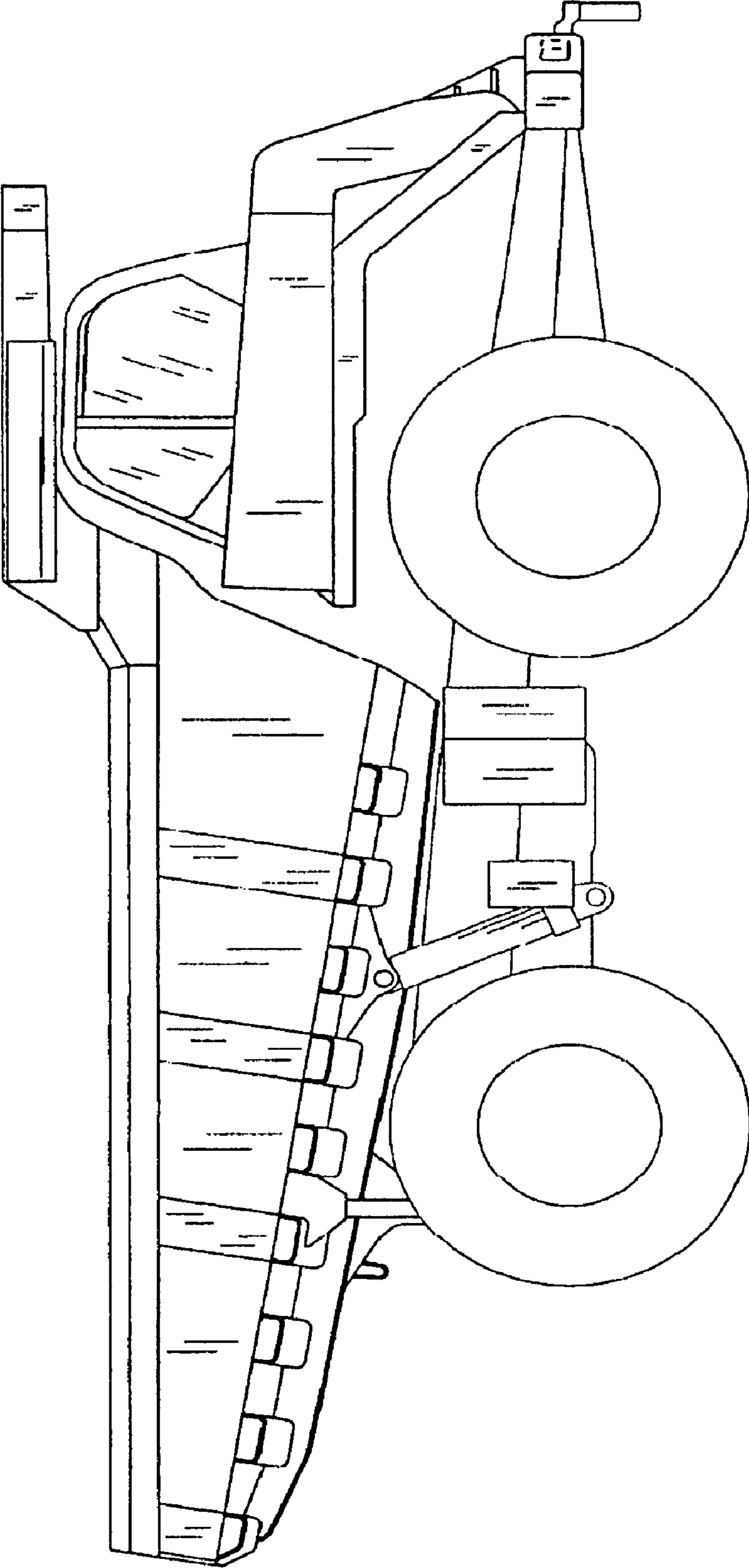

FIG. 2

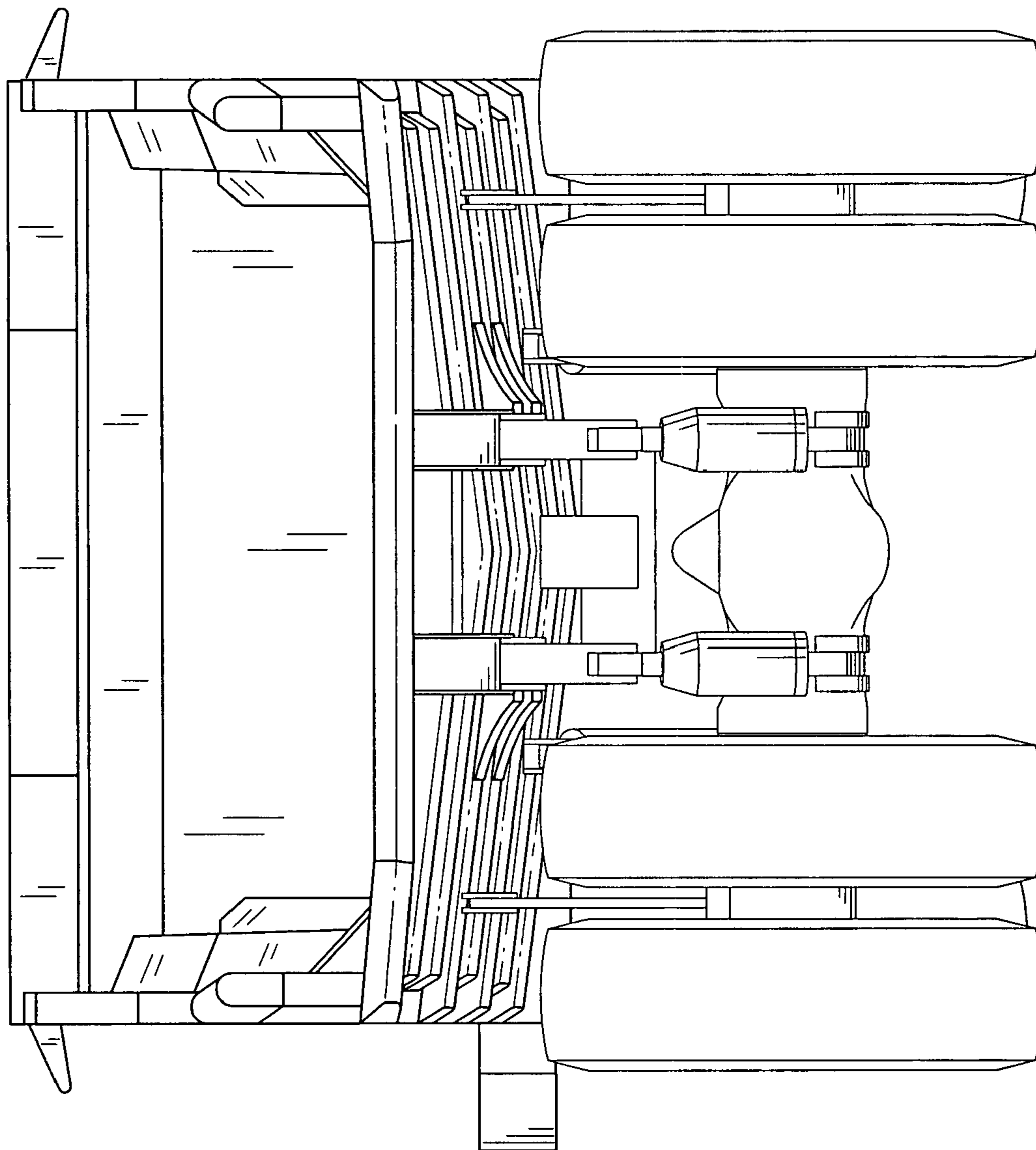
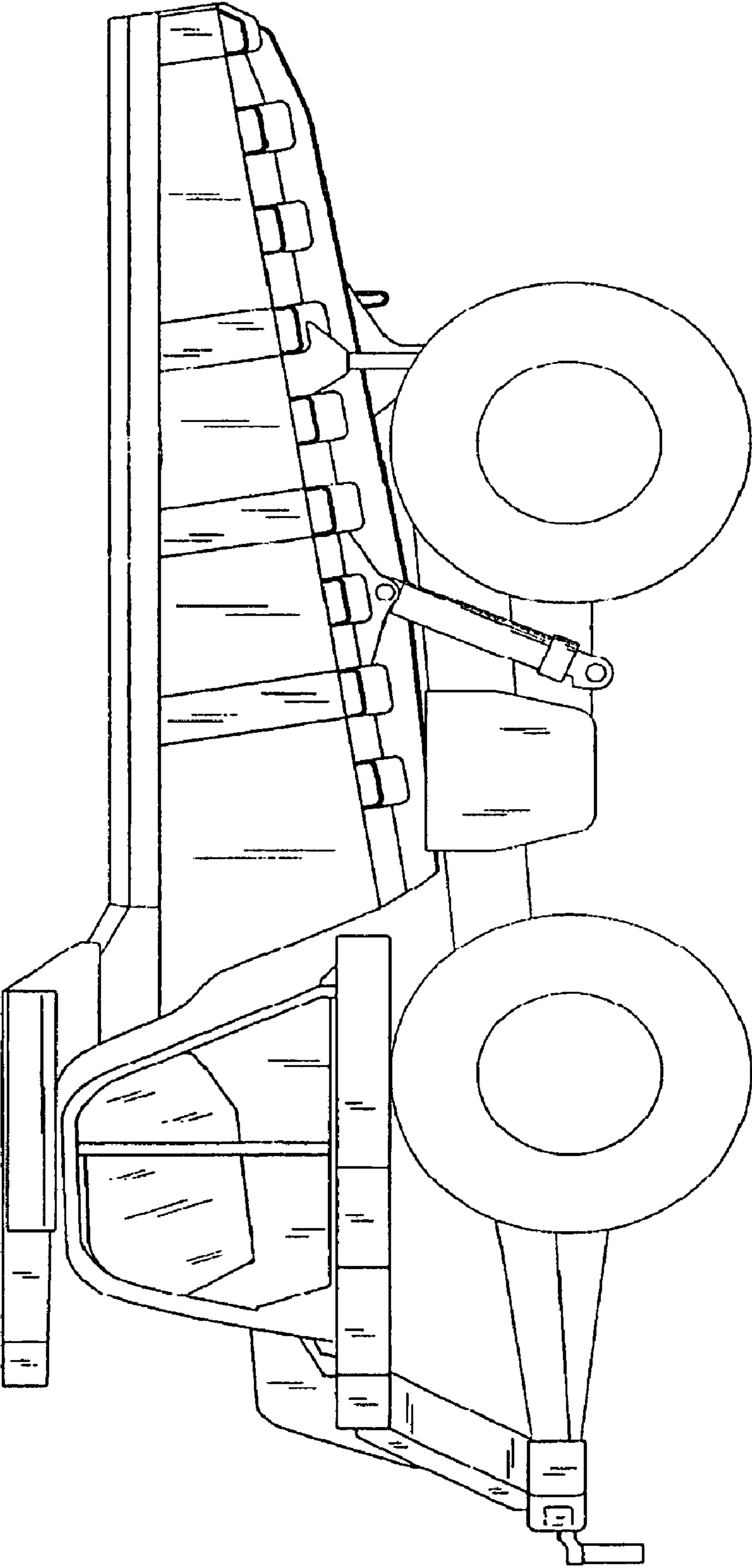

FIG. 3

FIG. 4



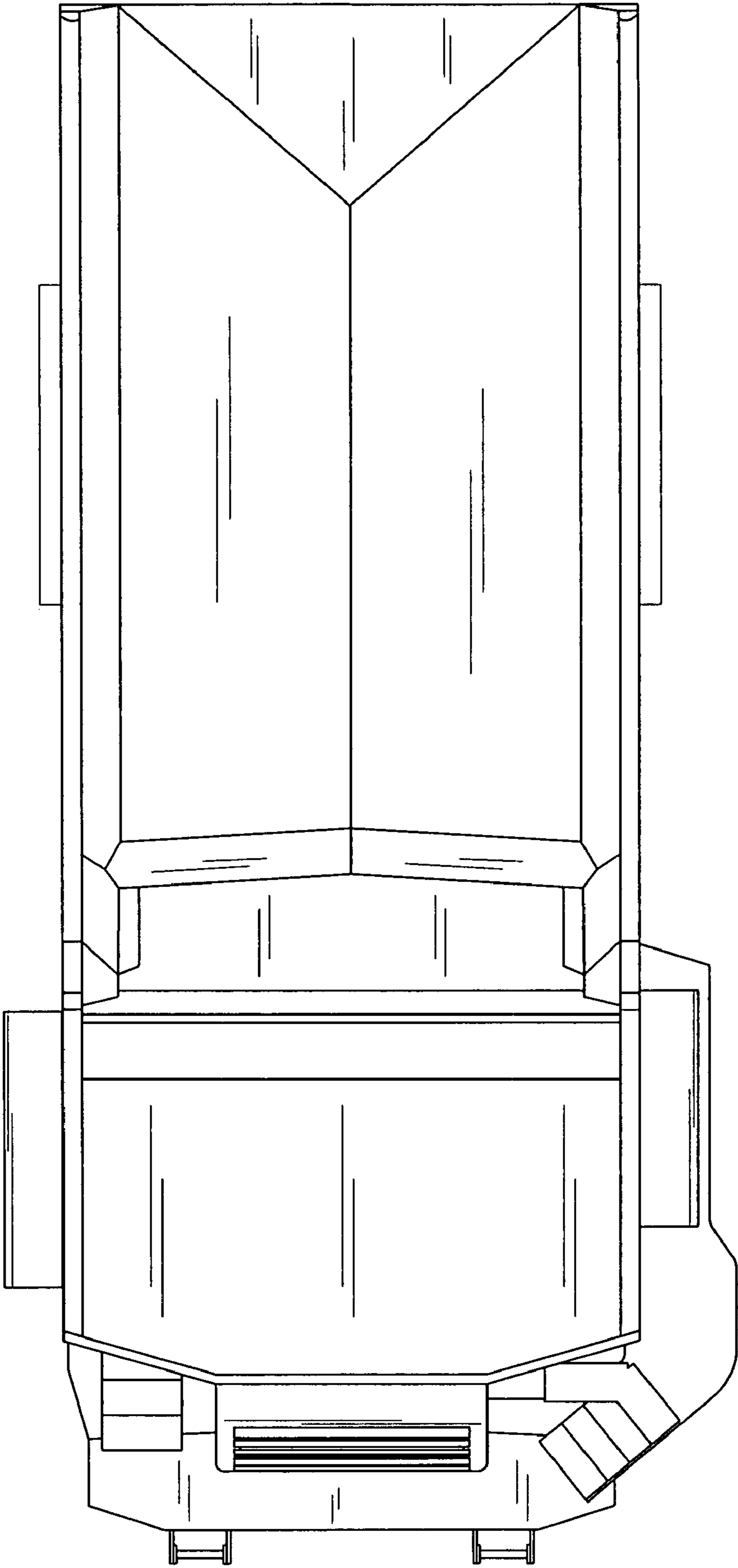

FIG. 5

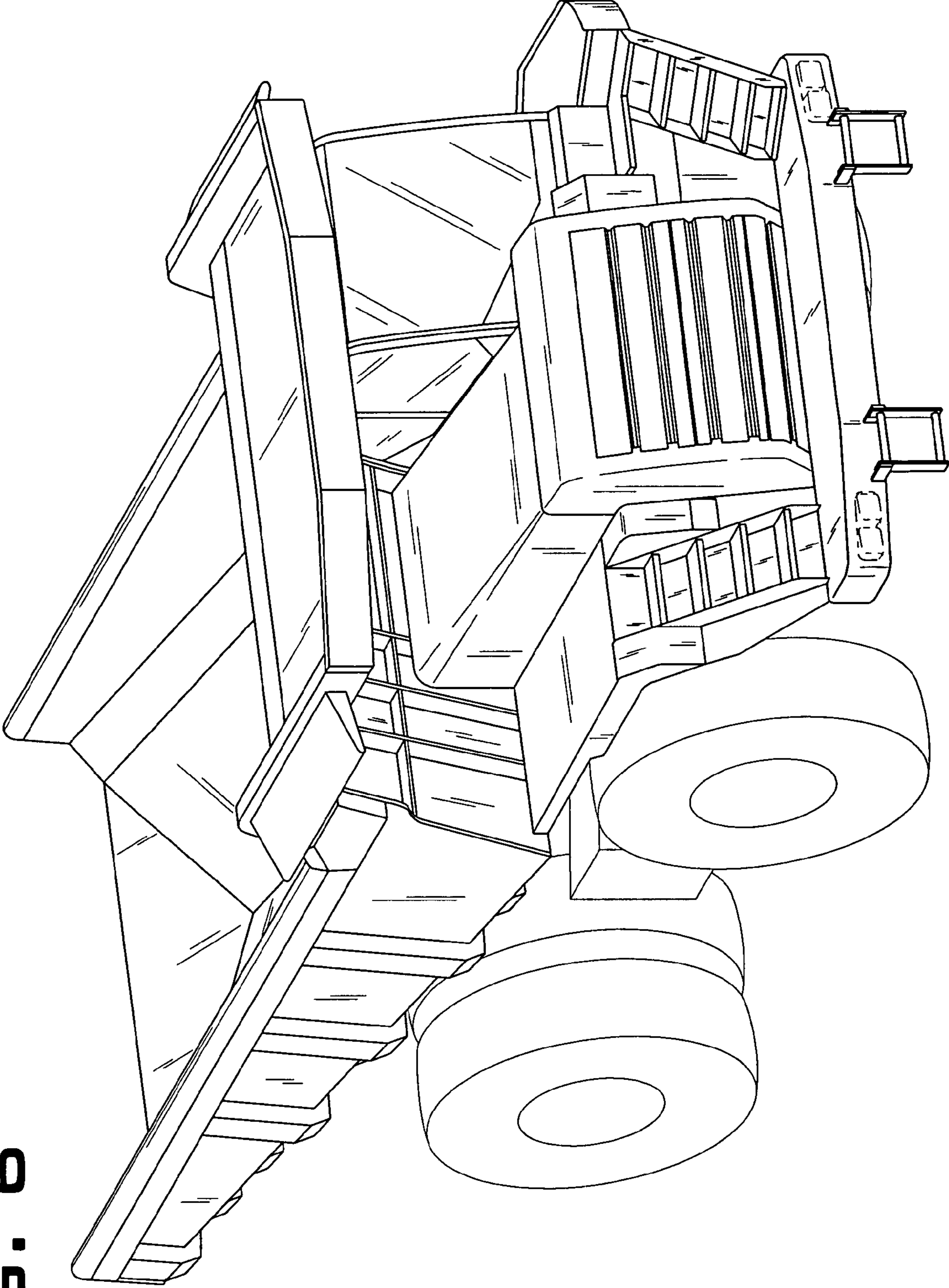

FIG. 6

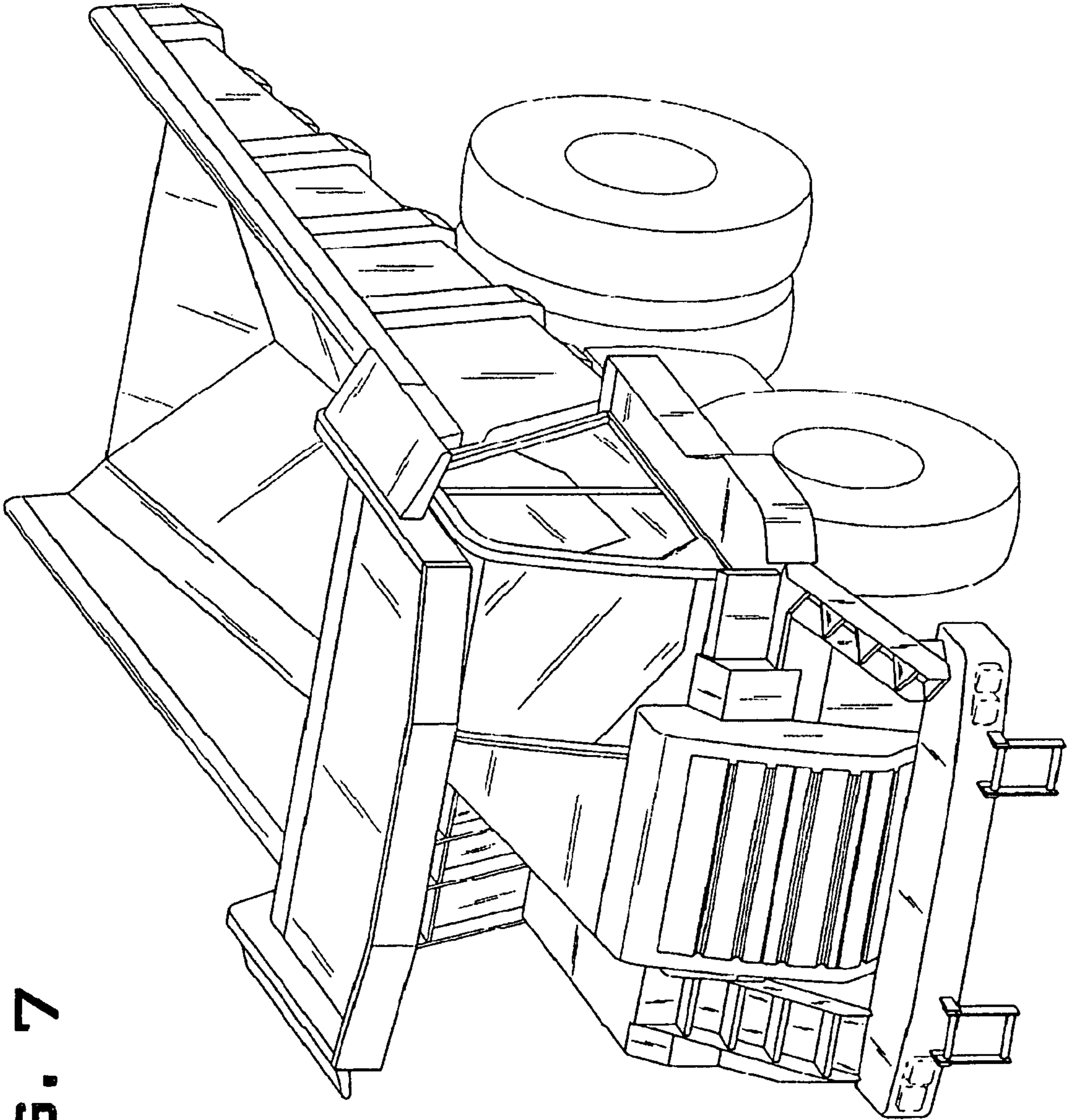

FIG. 7