



US00D596012S

(12) **United States Design Patent**
Ferrer et al.

(10) **Patent No.:** **US D596,012 S**
(45) **Date of Patent:** **** Jul. 14, 2009**

(54) **ADJUSTABLE ATTACHMENT MECHANISM**

6,052,832 A 4/2000 Crompton
7,090,181 B2 8/2006 Biba et al.
7,100,881 B2 9/2006 Worrall
7,193,783 B2 3/2007 Willey et al.

(75) Inventors: **Vincent J. Ferrer**, Pittsford, NY (US);
Stephen Glaser, Pittsford, NY (US);
David Alan Vogler, Rochester, NY (US)

* cited by examiner

(73) Assignee: **Vuzix Corporation**, Rochester, NY (US)

Primary Examiner—Holly H Baynham

(**) Term: **14 Years**

(74) *Attorney, Agent, or Firm*—Stephen B. Salai, Esq.;
Michael J. Didas, Esq.; Harter Secrest & Emery LLP

(21) Appl. No.: **29/280,899**

(57) **CLAIM**

(22) Filed: **Jun. 8, 2007**

The ornamental design for the adjustable attachment mechanism, as shown and described.

(51) **LOC (9) Cl.** **08-05**

(52) **U.S. Cl.** **D8/355**

(58) **Field of Classification Search** D8/349,
D8/354, 382, 355; 248/288.31; 403/56
See application file for complete search history.

DESCRIPTION

FIG. 1 is a perspective view of the adjustable attachment mechanism according to a preferred embodiment of the invention.

(56) **References Cited**

U.S. PATENT DOCUMENTS

1,382,783 A	6/1921	Howard	
2,460,880 A	2/1949	Geizer et al.	
4,225,258 A *	9/1980	Thompson	403/56
4,231,117 A	11/1980	Aileo	
4,898,490 A *	2/1990	Herbermann et al.	403/56
5,257,094 A	10/1993	LaRussa	
5,383,738 A	1/1995	Herbermann	
5,419,522 A	5/1995	Luecke et al.	
5,581,806 A	12/1996	Capdepuy et al.	
5,845,885 A	12/1998	Carnevali	
5,921,694 A *	7/1999	Herbermann	403/56
6,017,010 A	1/2000	Cui	

FIG. 2 is a top view of the adjustable attachment mechanism of FIG. 1, the bottom view being a mirror image thereof.

FIG. 3 is an elevation end view of the adjustable attachment mechanism of FIG. 1, the opposite end being a mirror image thereof; and ,

FIG. 4 is a front elevation view of the adjustable attachment mechanism of FIG. 1, the rear elevation view being a mirror image thereof.

The broken line showing is included for the purpose of illustrating environment and forms no part of the part of the claim design.

1 Claim, 3 Drawing Sheets

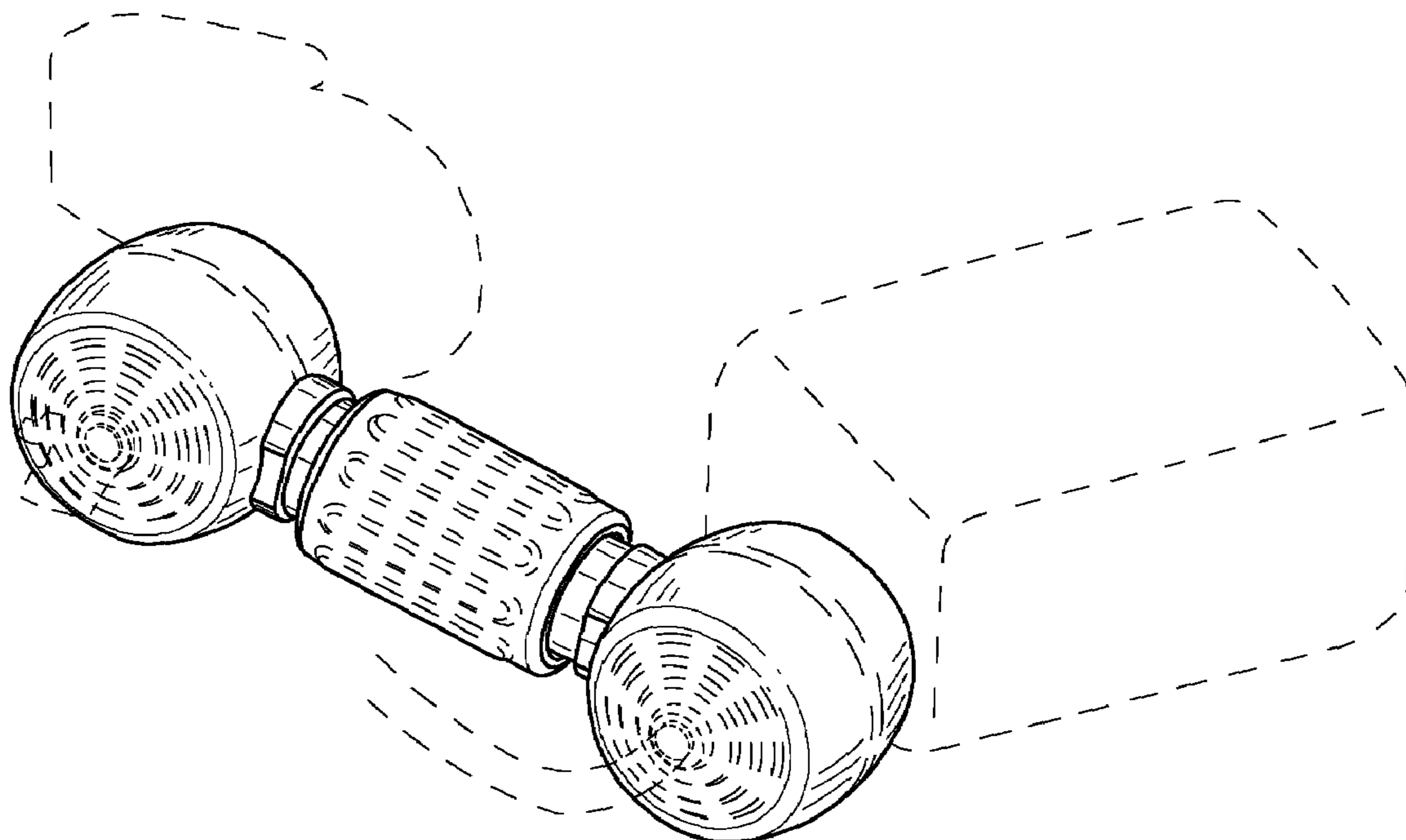

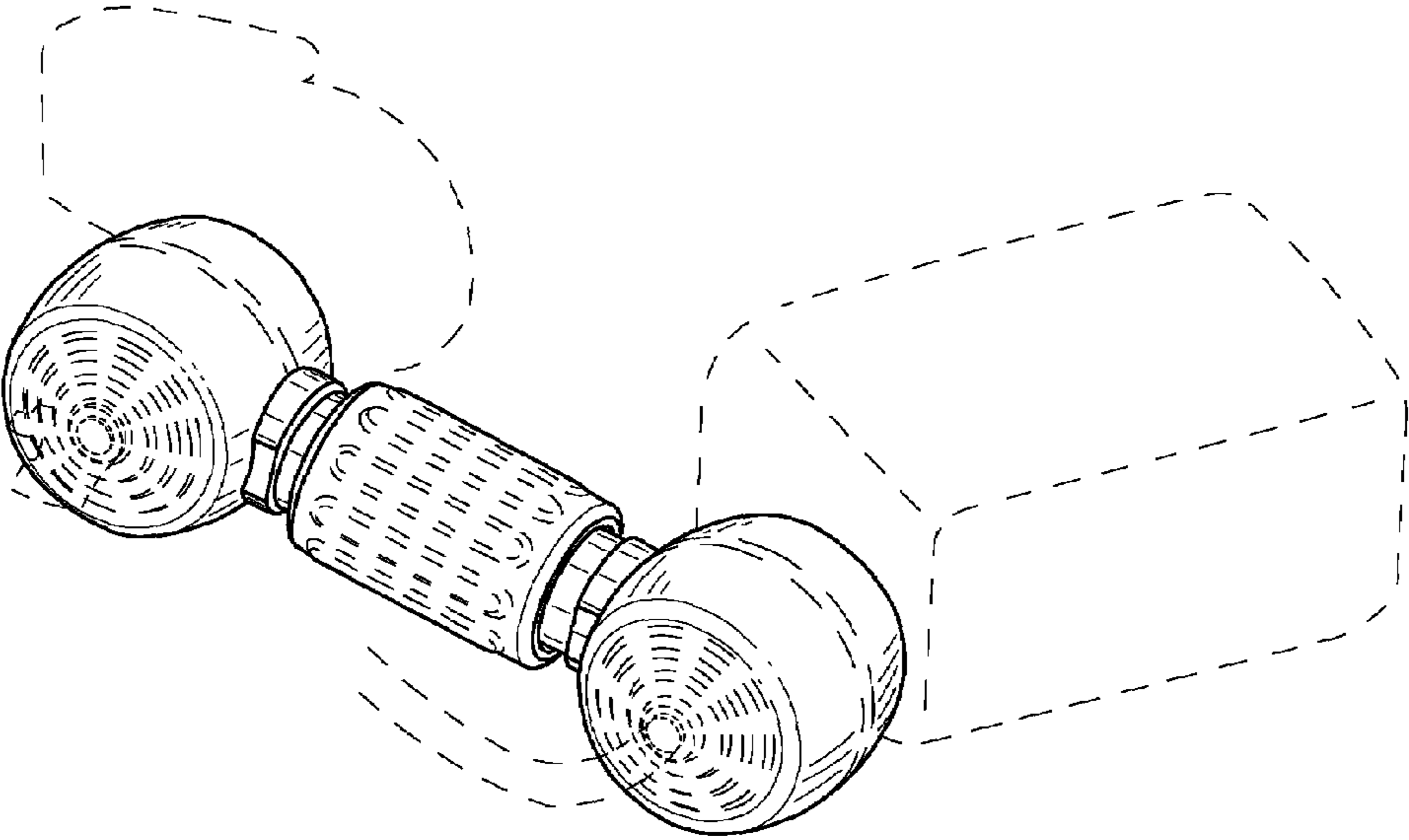

FIG. 1

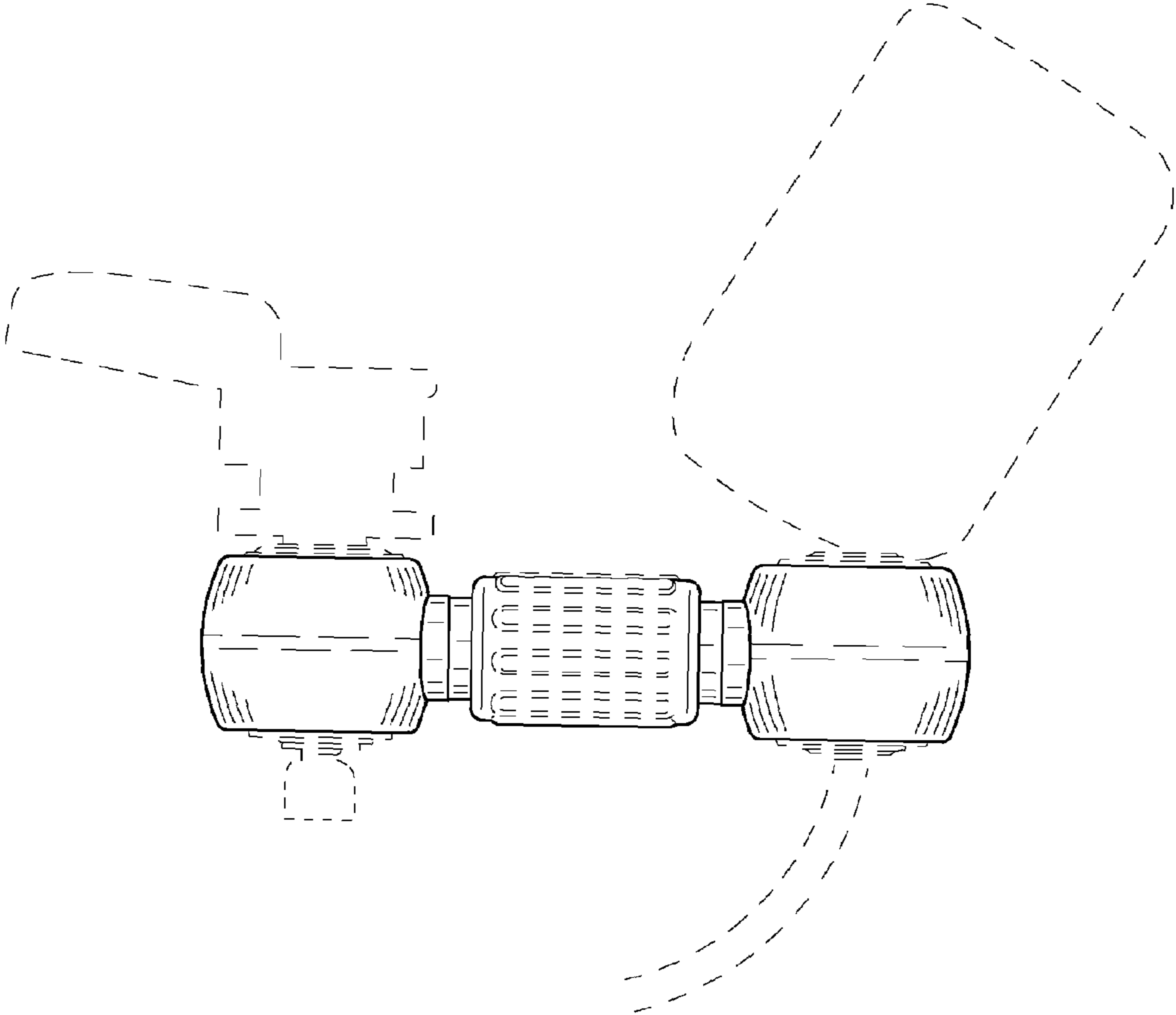

FIG. 2

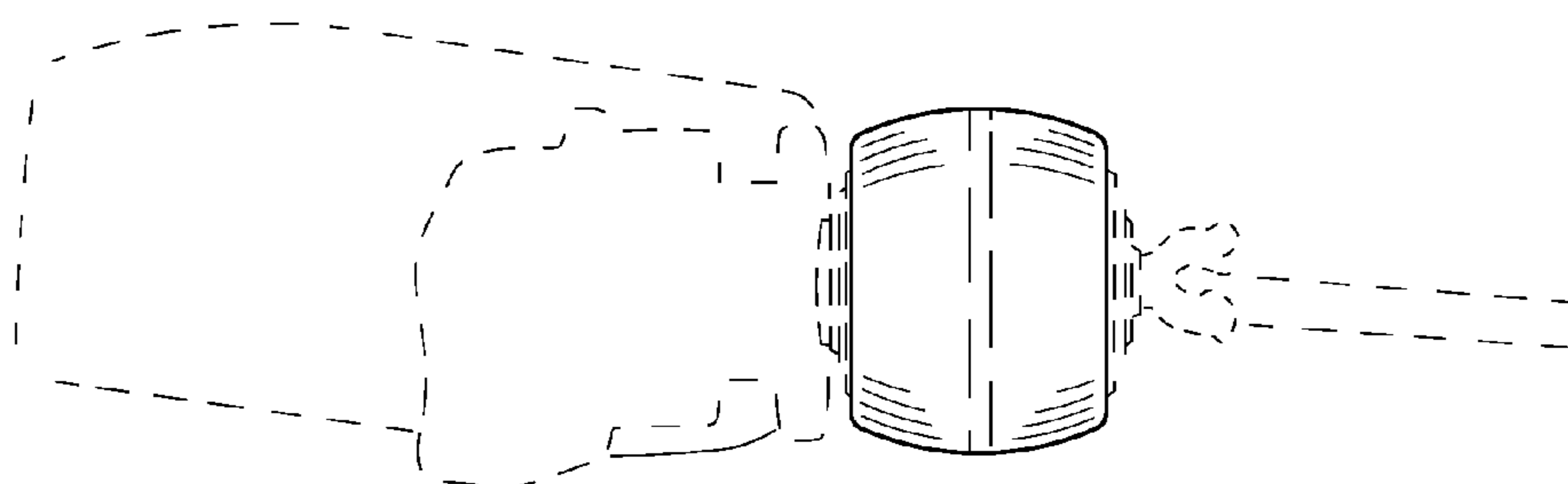

FIG. 3

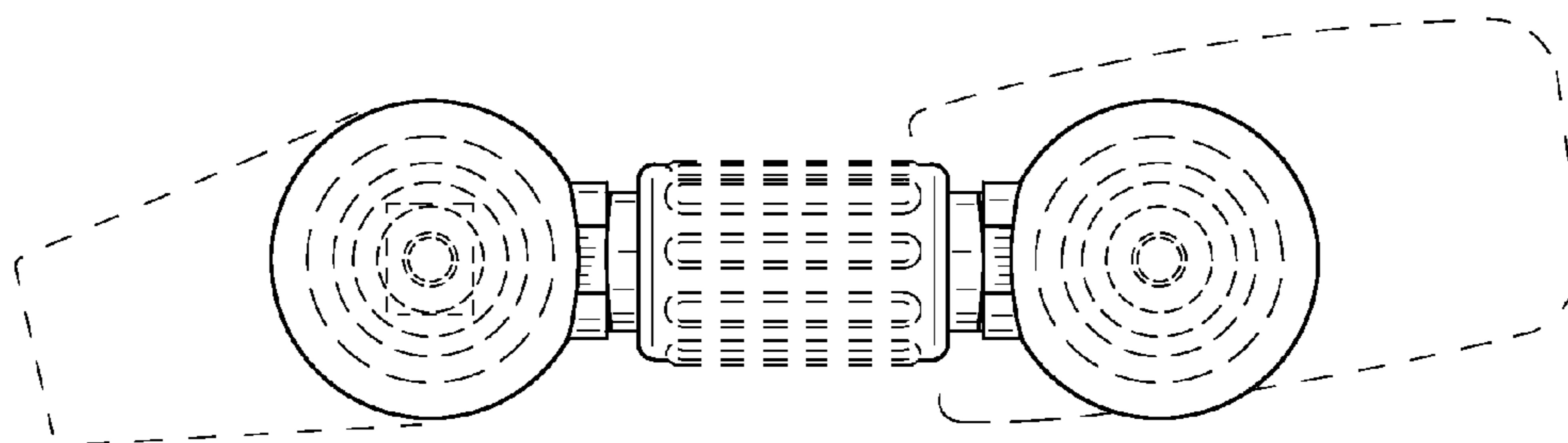

FIG. 4