

US00D595991S

(12) **United States Design Patent**  
**Zimmerman**

(10) **Patent No.:** **US D595,991 S**

(45) **Date of Patent:** **\*\* Jul. 14, 2009**

(54) **COFFEE MACHINE**

(75) Inventor: **Dirk Hagen Zimmerman**, Düsseldorf (DE)

(73) Assignee: **WIK Far East, Ltd.**, North Point, Hong Kong (CN)

(\*\*) Term: **14 Years**

(21) Appl. No.: **29/320,723**

(22) Filed: **Jul. 2, 2008**

(51) **LOC (9) Cl.** ..... **07-01**

(52) **U.S. Cl.** ..... **D7/307; D7/308; D7/309; D7/311**

(58) **Field of Classification Search** ..... **D7/300, D7/306-312; 99/285, 295, 287, 282, 293, 99/323.1, 304**

See application file for complete search history.

(56) **References Cited**

**U.S. PATENT DOCUMENTS**

3,327,615 A	6/1967	Swan	
4,644,856 A	2/1987	Borgmann	
D319,943 S *	9/1991	Sexton et al.	D7/308
D385,455 S	10/1997	Cortese	
D390,060 S	2/1998	Seiffert	
D424,361 S	5/2000	Kuboyama	
D444,986 S	7/2001	Smith et al.	
D449,198 S	10/2001	Cahen	
D481,580 S *	11/2003	Daniels et al.	D7/309
D486,346 S	2/2004	Jonsson	
D495,189 S	8/2004	Cahen	
D523,279 S *	6/2006	Zemp	D7/309
D528,845 S	9/2006	Zimmermann	
D556,494 S *	12/2007	Adachi et al.	D7/308
D557,057 S *	12/2007	Einav	D7/307

7,307,071 B2 *	12/2007	Lyons et al.	514/183
D563,143 S *	3/2008	Tonelli	D7/306
D573,392 S *	7/2008	Smith	D7/306
D584,096 S *	1/2009	Lutz	D7/307
D586,603 S *	2/2009	Borin	D7/309
D586,604 S *	2/2009	Buttler	D7/309
D587,511 S *	3/2009	Buttler	D7/309
D587,956 S *	3/2009	Adachi	D7/308

**OTHER PUBLICATIONS**

U.S. Appl. No. 29/320,722, filed Jul. 2, 2008; Inventor: Dirk Hagen Zimmermann.

U.S. Appl. No. 29/320,114, filed Jun. 20, 2008; Inventor: Christoph Speh.

\* cited by examiner

*Primary Examiner*—Marianne Pandozzi

(74) *Attorney, Agent, or Firm*—Margaret Polson; Oppedahl Patent Law Firm LLC

(57) **CLAIM**

The ornamental design for a coffee machine, as shown and described.

**DESCRIPTION**

FIG. 1 is a front perspective view of my new design for a coffee machine.

FIG. 2 is a front elevational view thereof;

FIG. 3 is a rear elevational view thereof;

FIG. 4 is a right side elevation view of FIG. 1.

FIG. 5 is a left side elevation view of FIG. 1.

FIG. 6 is a top plan view thereof; and,

FIG. 7 is a bottom plan view thereof.

**1 Claim, 5 Drawing Sheets**

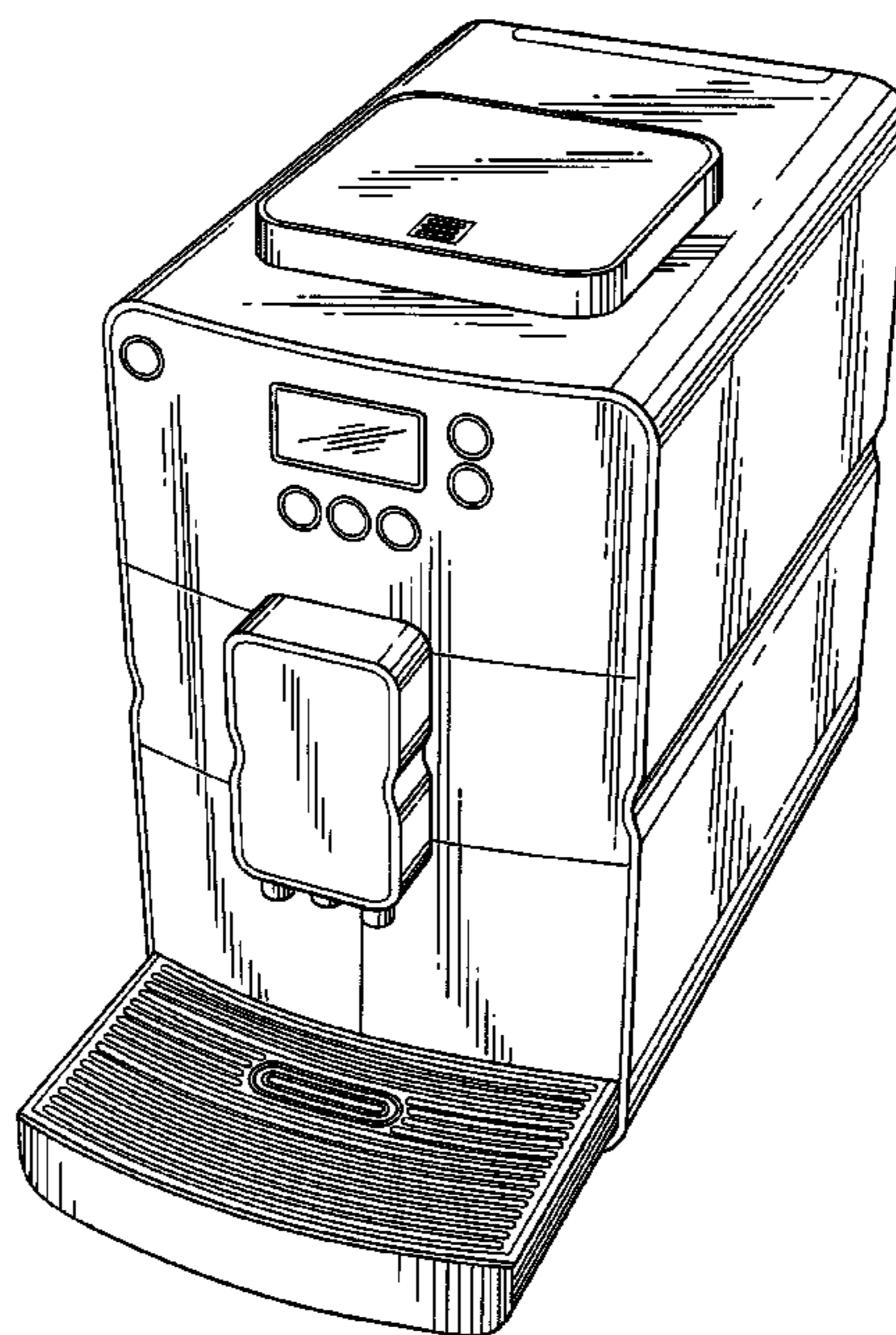

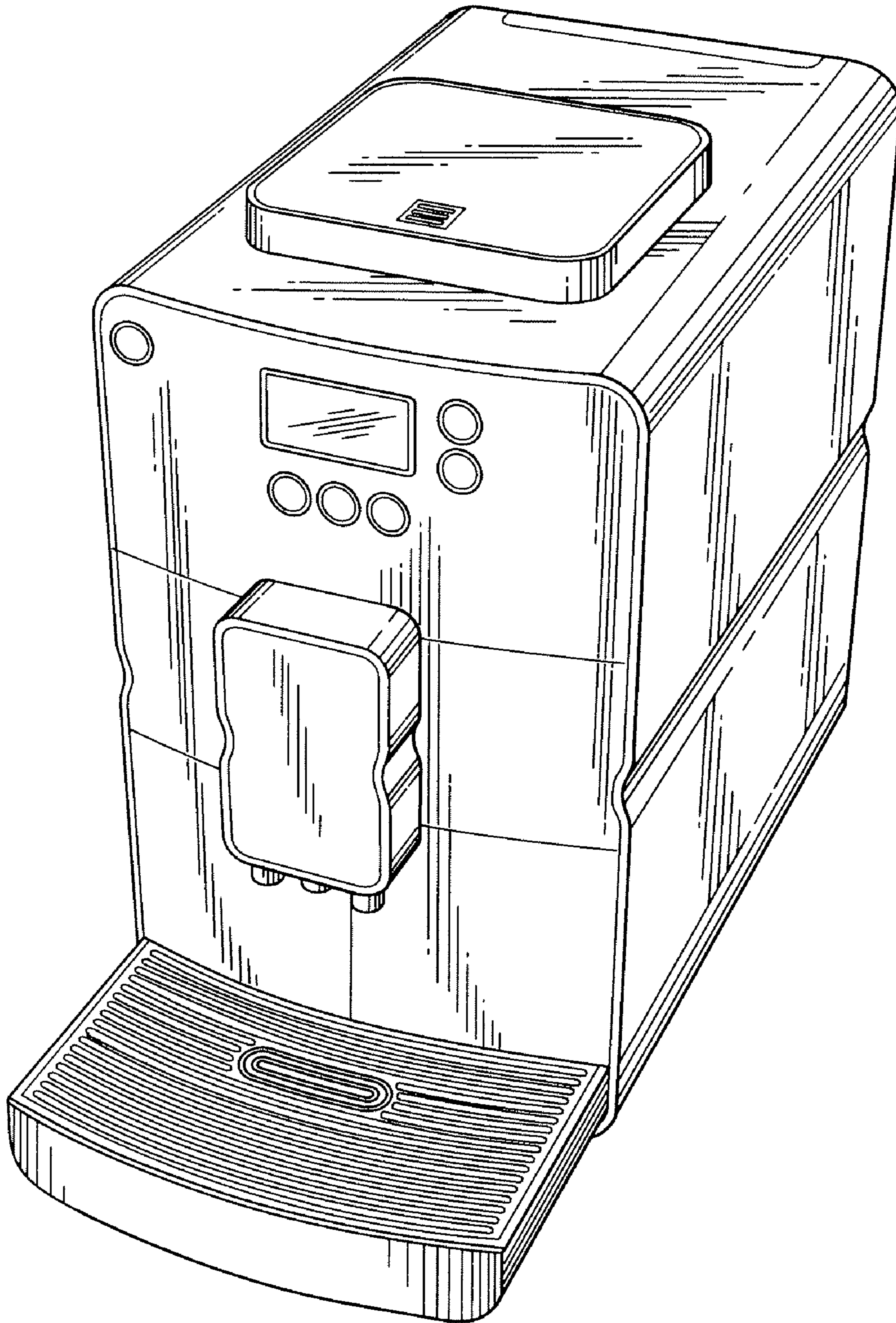

FIG. 1

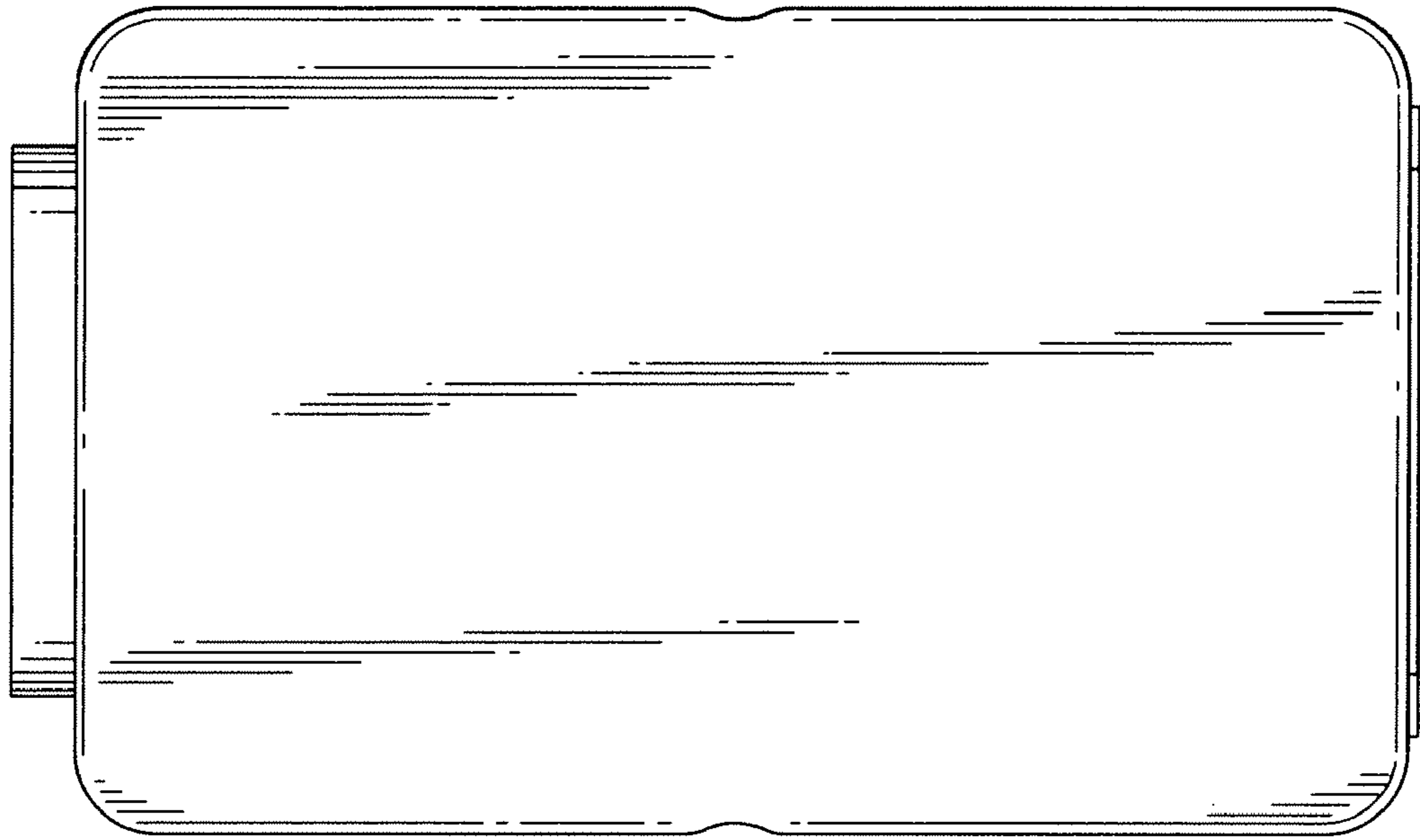

FIG.3

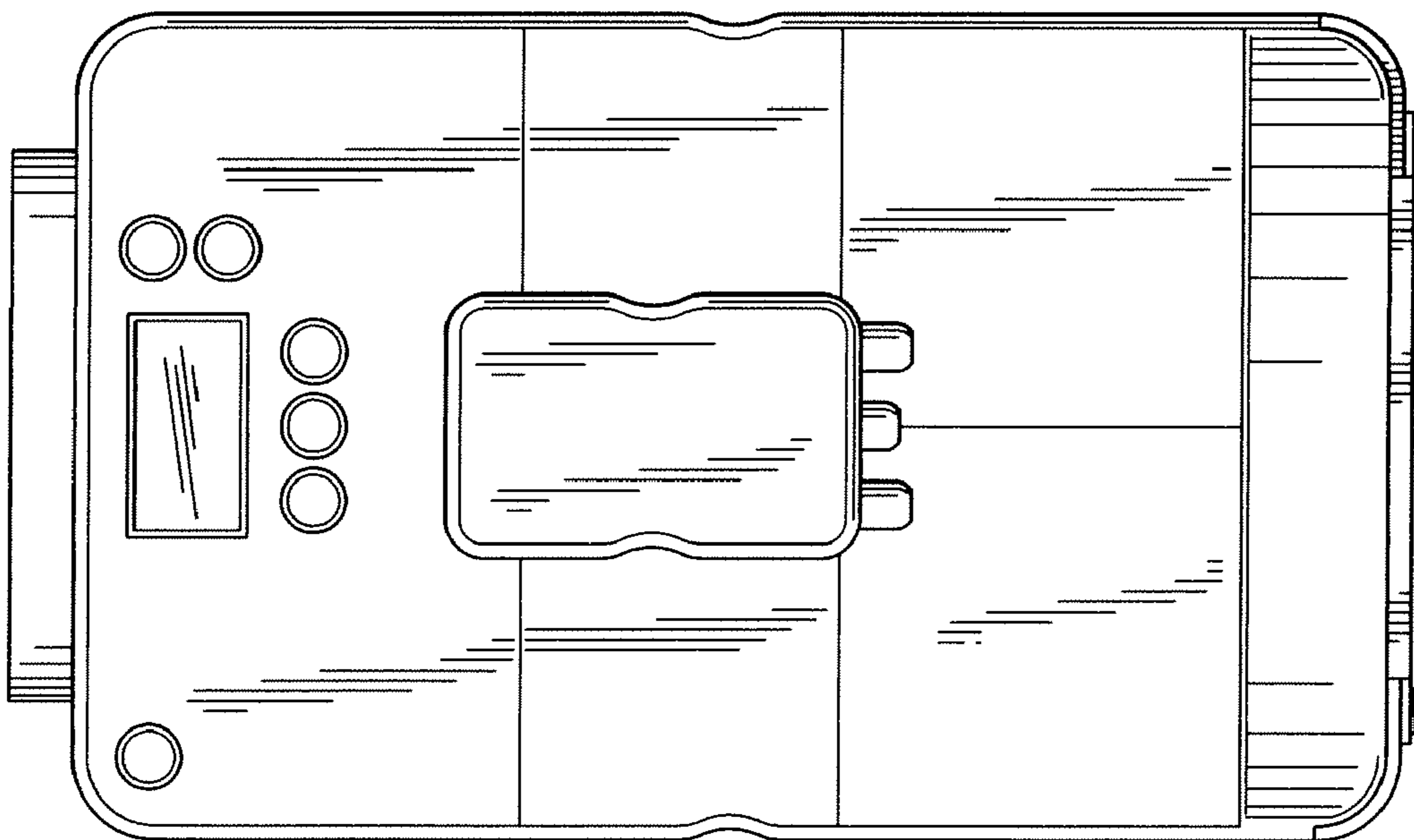

FIG.2

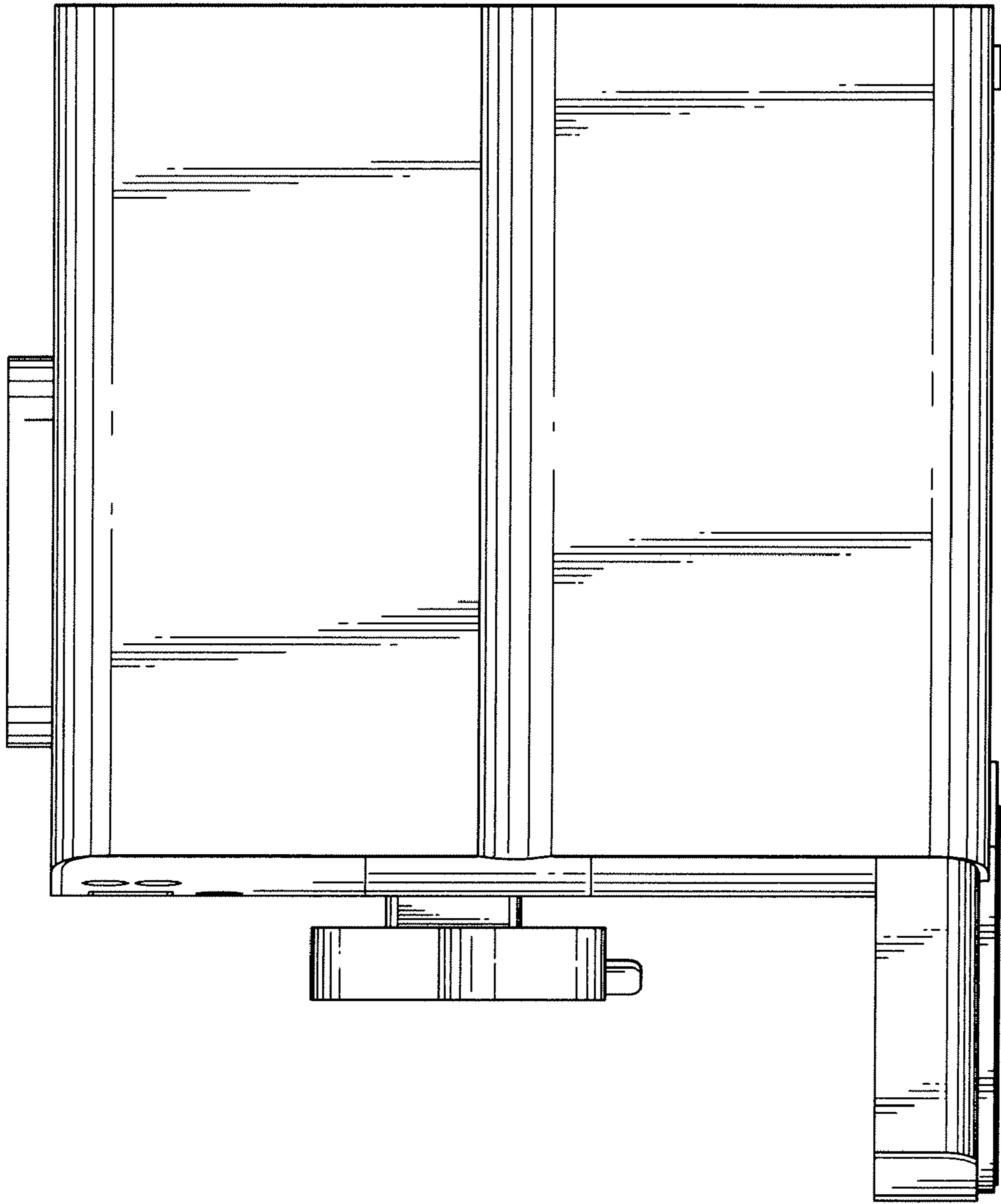

FIG.4

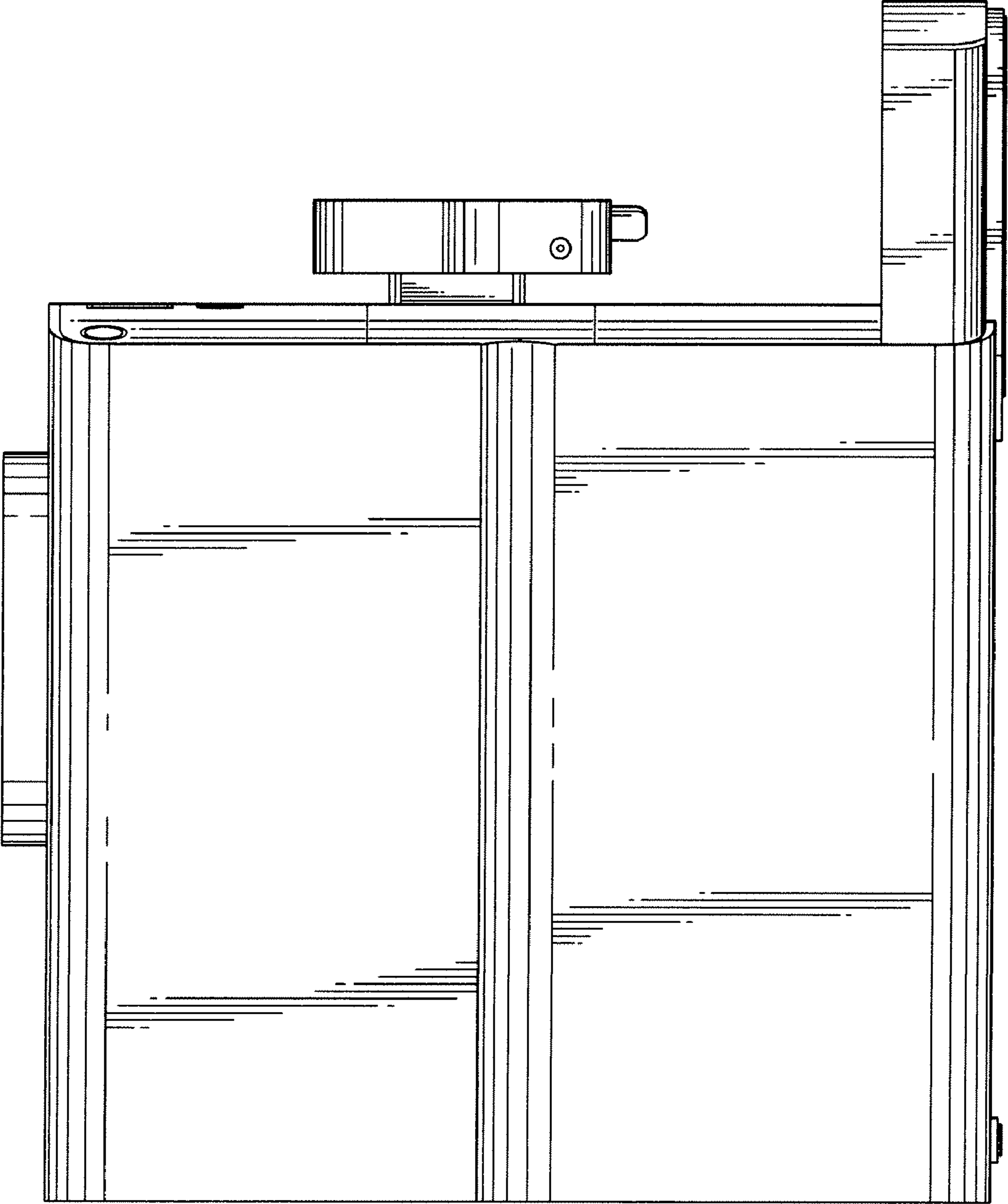

FIG.5

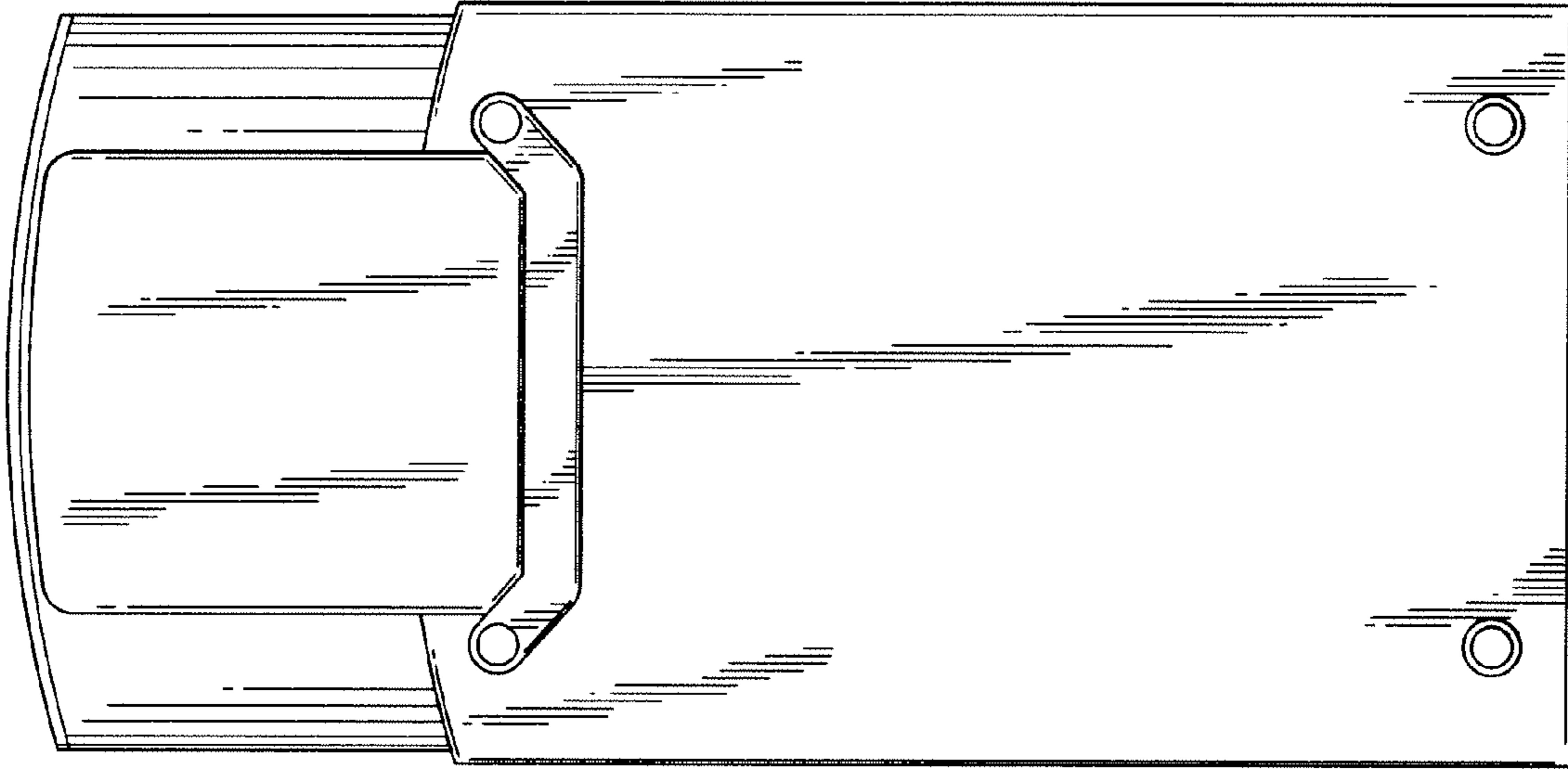

FIG. 7

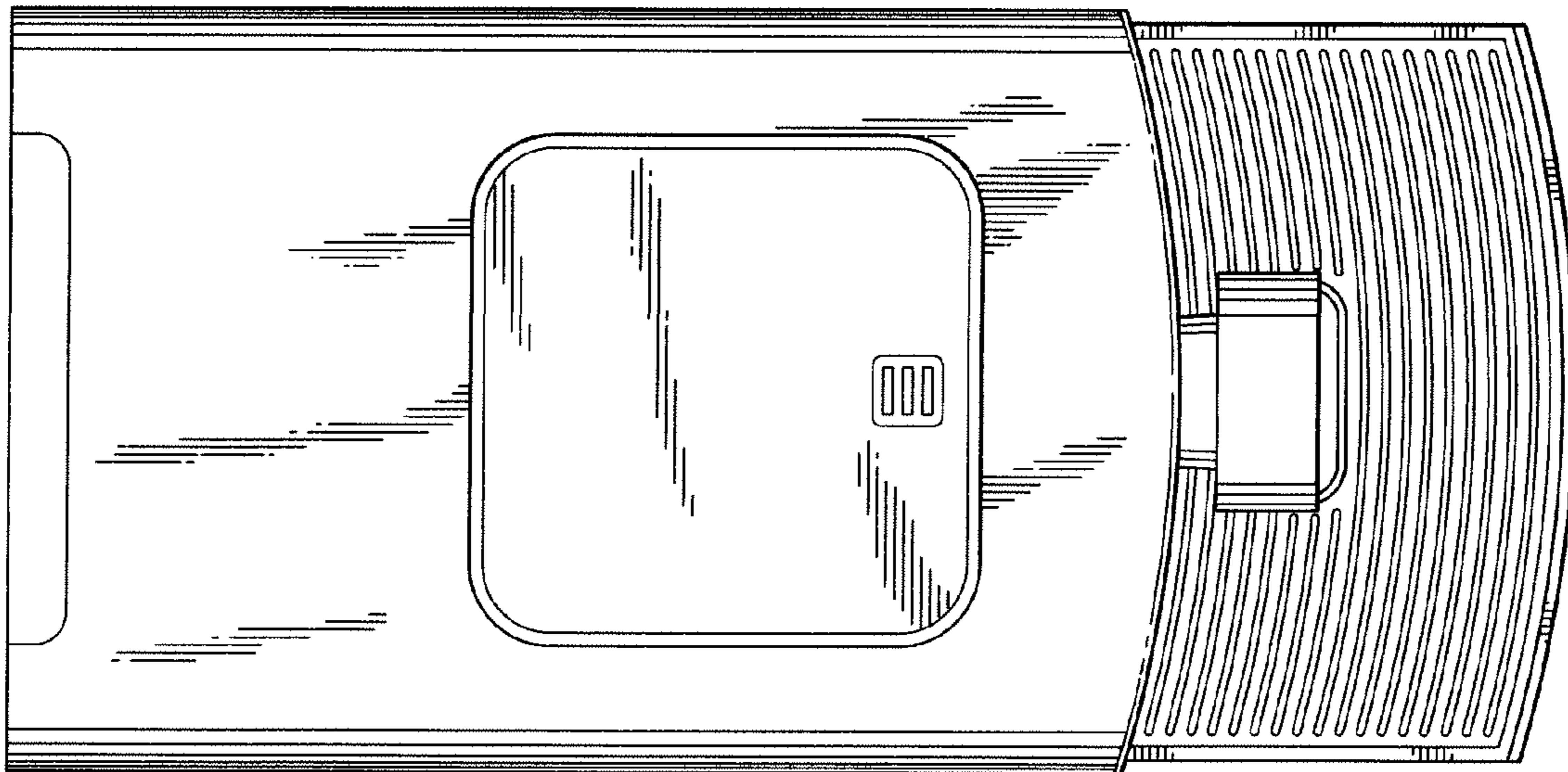

FIG. 6