



US00D595879S

(12) **United States Design Patent**
Lamm

(10) **Patent No.:** **US D595,879 S**
(45) **Date of Patent:** **** Jul. 7, 2009**

(54) **VEHICLE TAILLIGHT**

(75) Inventor: **Stefan Lamm**, Köln (DE)

(73) Assignee: **Ford Global Technologies, LLC**,
Dearborn, MI (US)

(**) Term: **14 Years**

(21) Appl. No.: **29/330,159**

(22) Filed: **Dec. 30, 2008**

(51) **LOC (9) Cl.** **26-06**

(52) **U.S. Cl.** **D26/28**

(58) **Field of Classification Search** D26/28-36;
362/459-468, 475-478, 485-487
See application file for complete search history.

(56) **References Cited**

U.S. PATENT DOCUMENTS

D549,363 S *	8/2007	Pfeiffer	D26/28
D552,769 S *	10/2007	Leclercq	D26/28
D553,268 S *	10/2007	Pfeiffer	D26/28
D553,269 S *	10/2007	Pfeiffer et al.	D26/28

* cited by examiner

Primary Examiner—Marcus A. Jackson

(74) *Attorney, Agent, or Firm*—Damian Porcari

(57) **CLAIM**

The ornamental design for a vehicle taillight, as shown and described.

DESCRIPTION

FIG. 1 is a rear elevational view of a left vehicle taillight (the right vehicle taillight being a mirror of the left and is not

illustrated), the lens having been rendered transparent using the Computer Aided Design tools to illustrate the internal surfaces;

FIG. 2 is a rear elevational view of the vehicle taillight, the lens having been rendered opaque using the Computer Aided Design tools to illustrate the external surfaces;

FIG. 3 is a left elevational view of the vehicle taillight, the lens having been rendered transparent using the Computer Aided Design tools to illustrate the internal surfaces;

FIG. 4 is a left elevational view of the vehicle taillight, the lens having been rendered opaque using the Computer Aided Design tools to illustrate the external surfaces.

FIG. 5 is a right elevational view of the vehicle taillight;

FIG. 6 is a top plan view of the vehicle taillight;

FIG. 7 is a bottom plan view of the vehicle taillight; and

FIG. 8 is a rear elevational view of the vehicle taillight, the lens having been rendered transparent using the Computer Aided Design tools to illustrate the external surfaces; and,

FIG. 9 is a rear elevational view of the vehicle taillight, the lens having been rendered opaque using the Computer Aided Design tools to illustrate the external surfaces.

The vehicle taillight is styled independently of adjacent vehicle panels. To the extent that any feature lines are illustrated, they are intended to illustrate the crest and valley of the feature and are not necessarily sharp bends in the part. Shading is used to illustrate the curvature of the part and not color. Areas shown in or sounded by broken lines are not claimed. Any functional features of the vehicle taillight are not claimed. Views are orthogonal projections unless otherwise noted. The various views are not necessarily to scale in order to better illustrate the design. The drawings were generated using Computer Aided Design tools. Highlights and shading were added to the drawings to better illustrate the three-dimensional features of the part. The vehicle headlight is intended to be observed in various states of internal illumination as well as in daylight with no internal illumination.

1 Claim, 9 Drawing Sheets

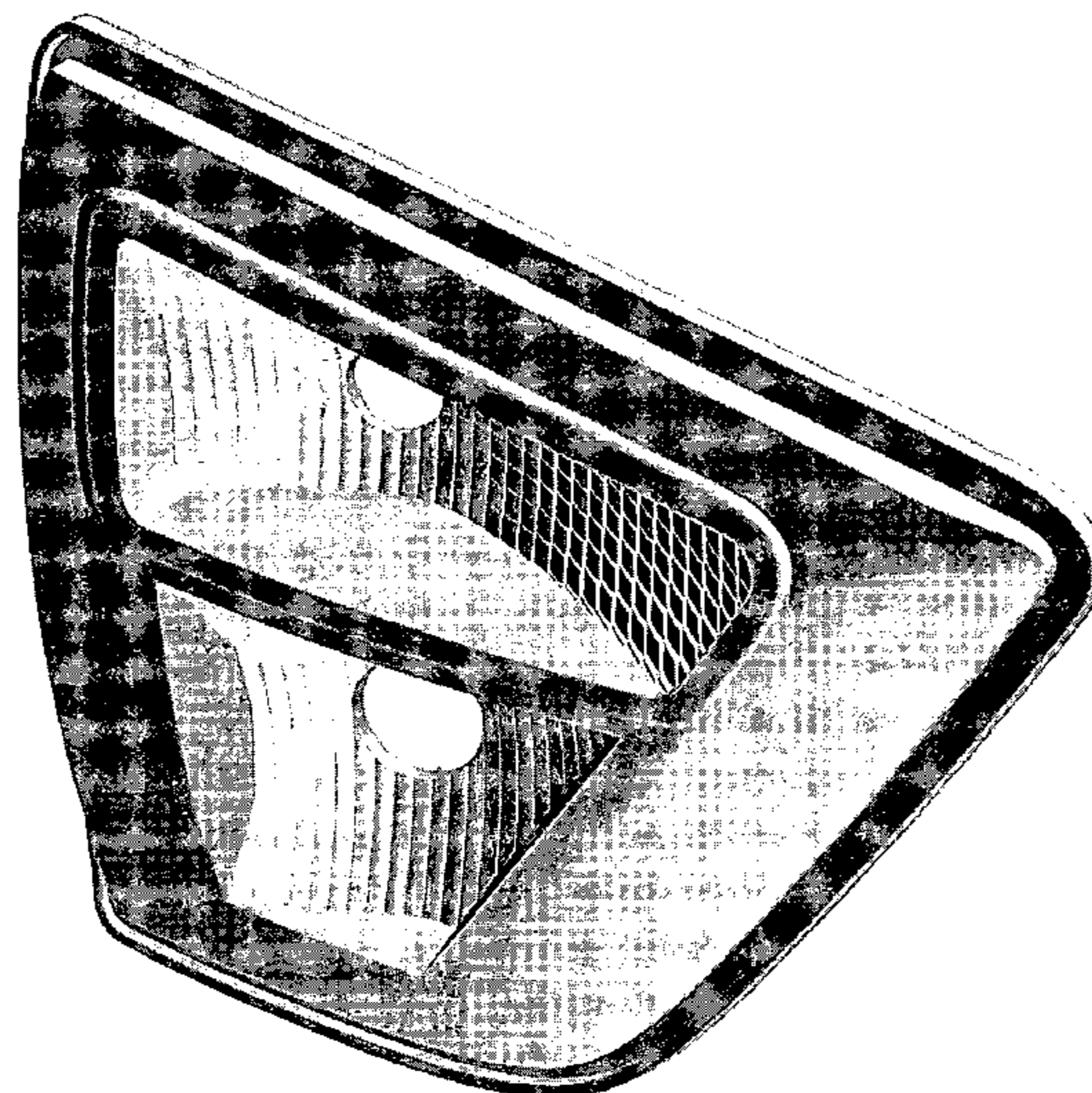

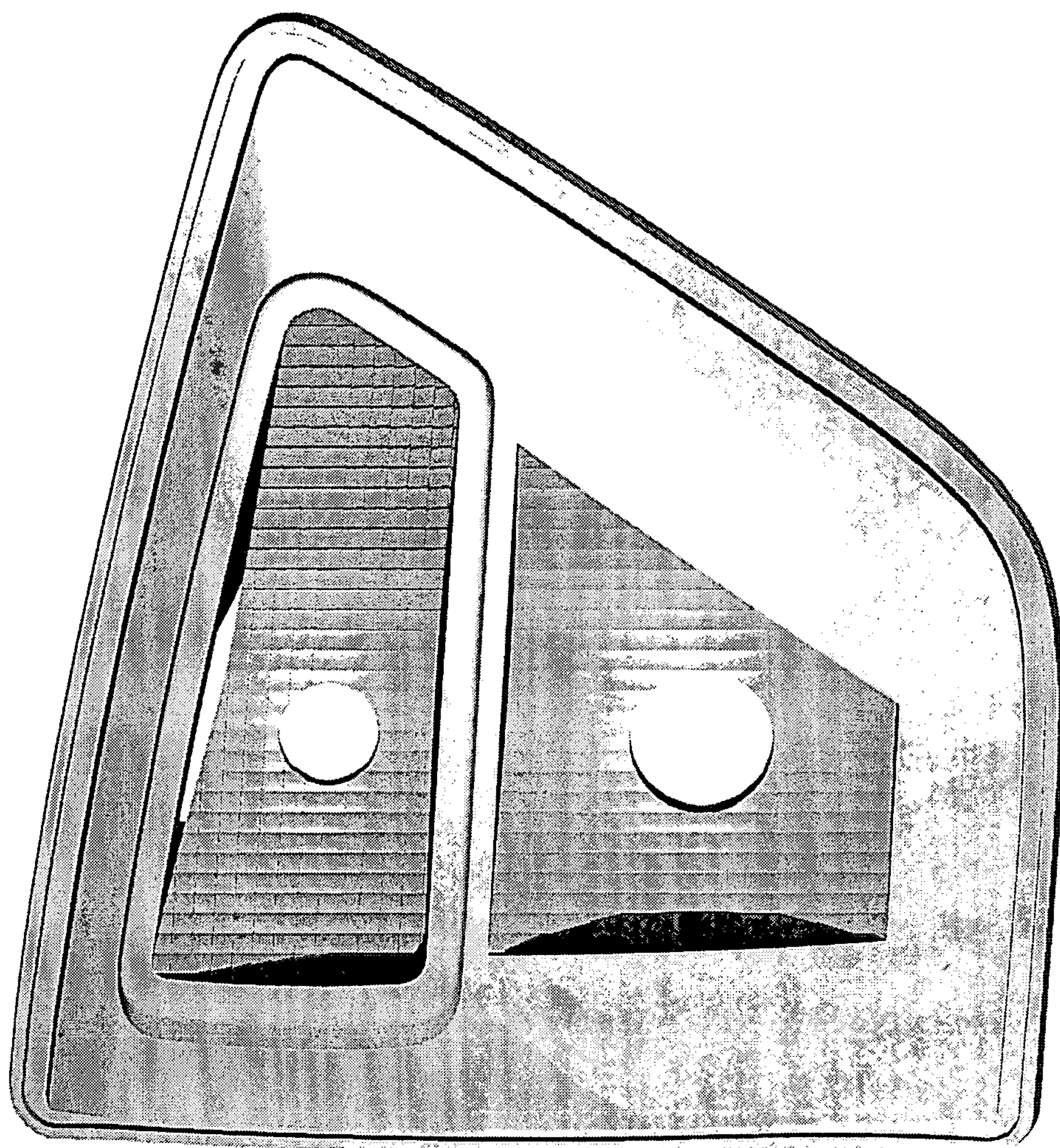

Figure 1

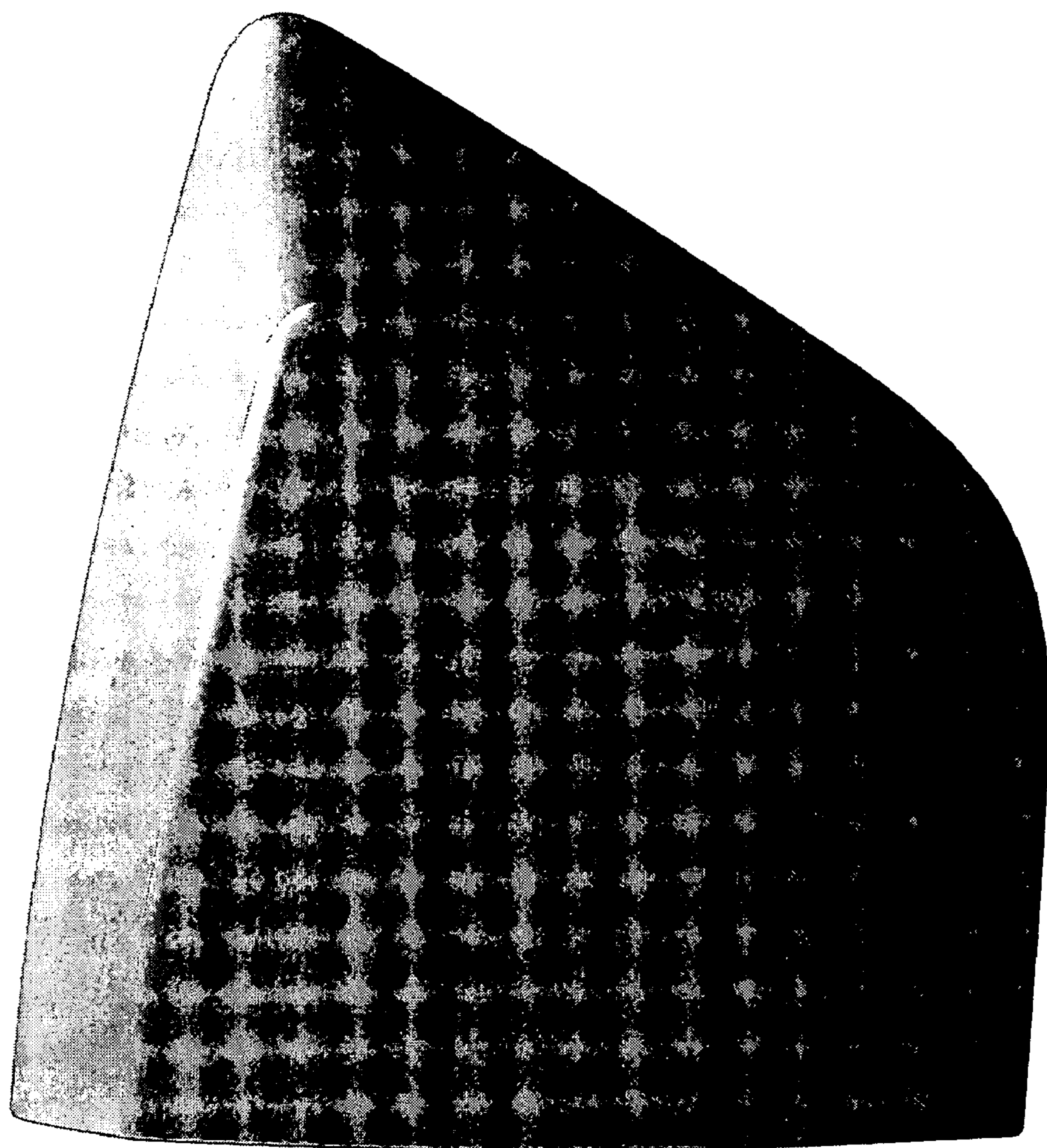

Figure 2

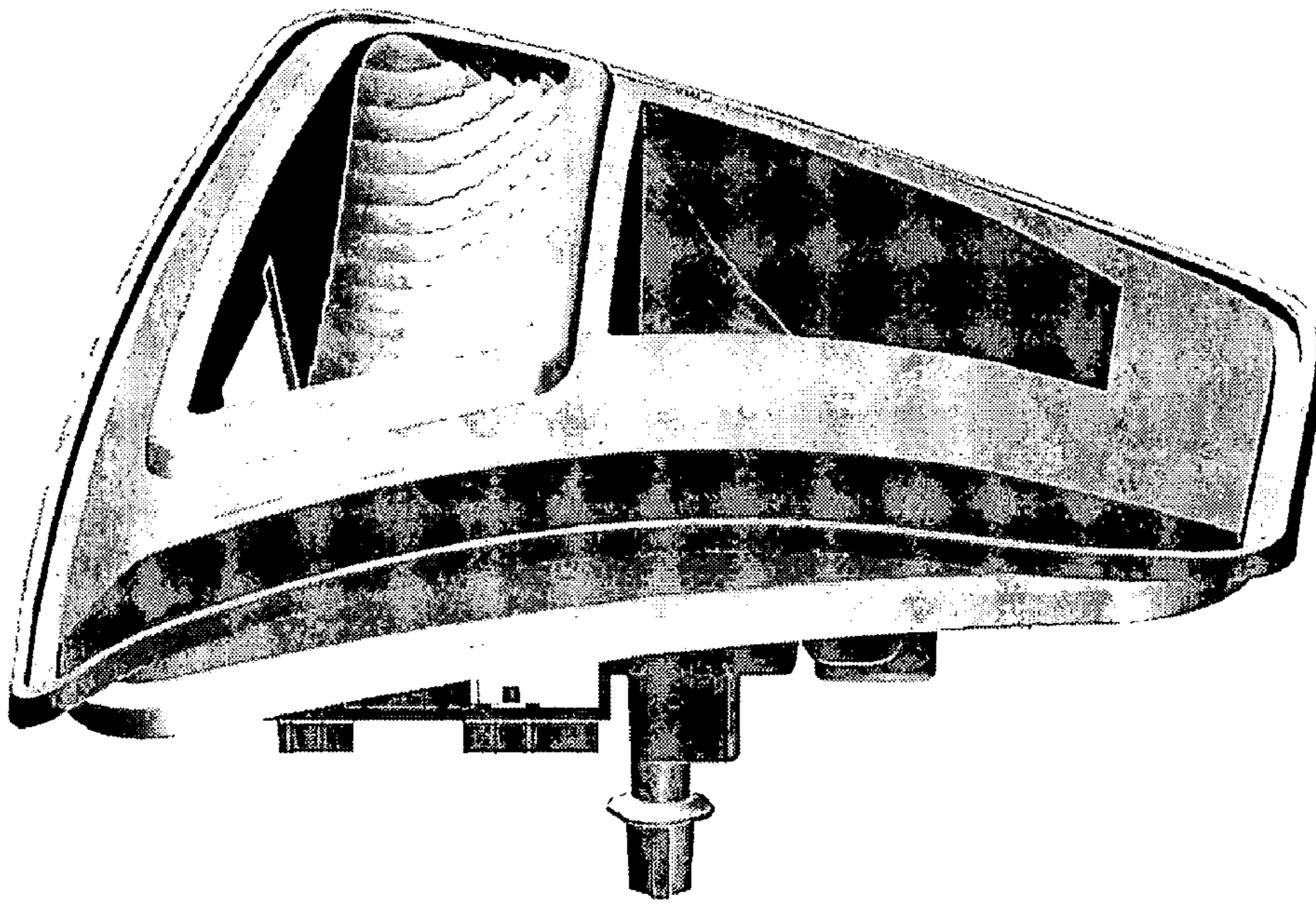

Figure 3

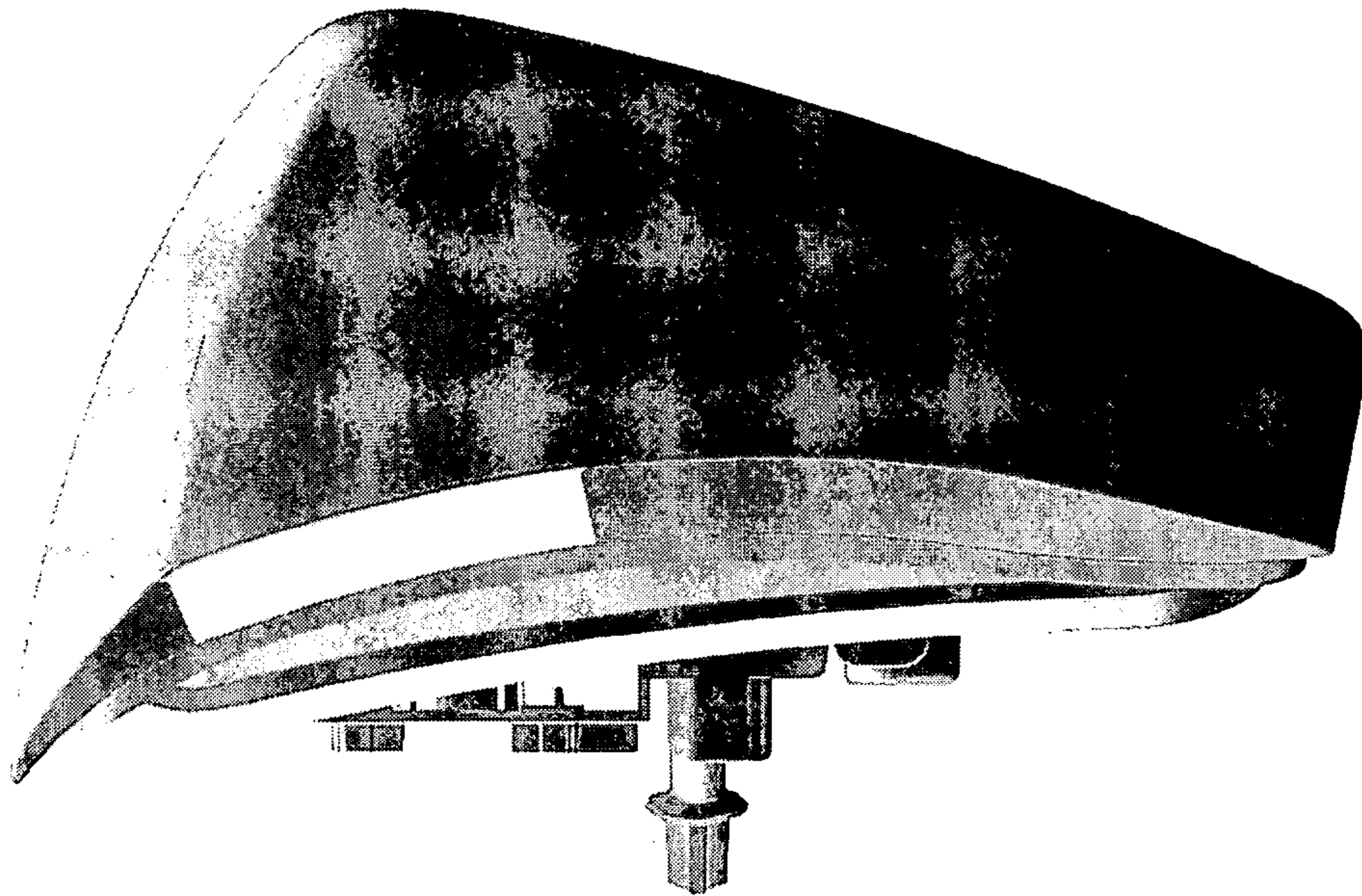

Figure 4

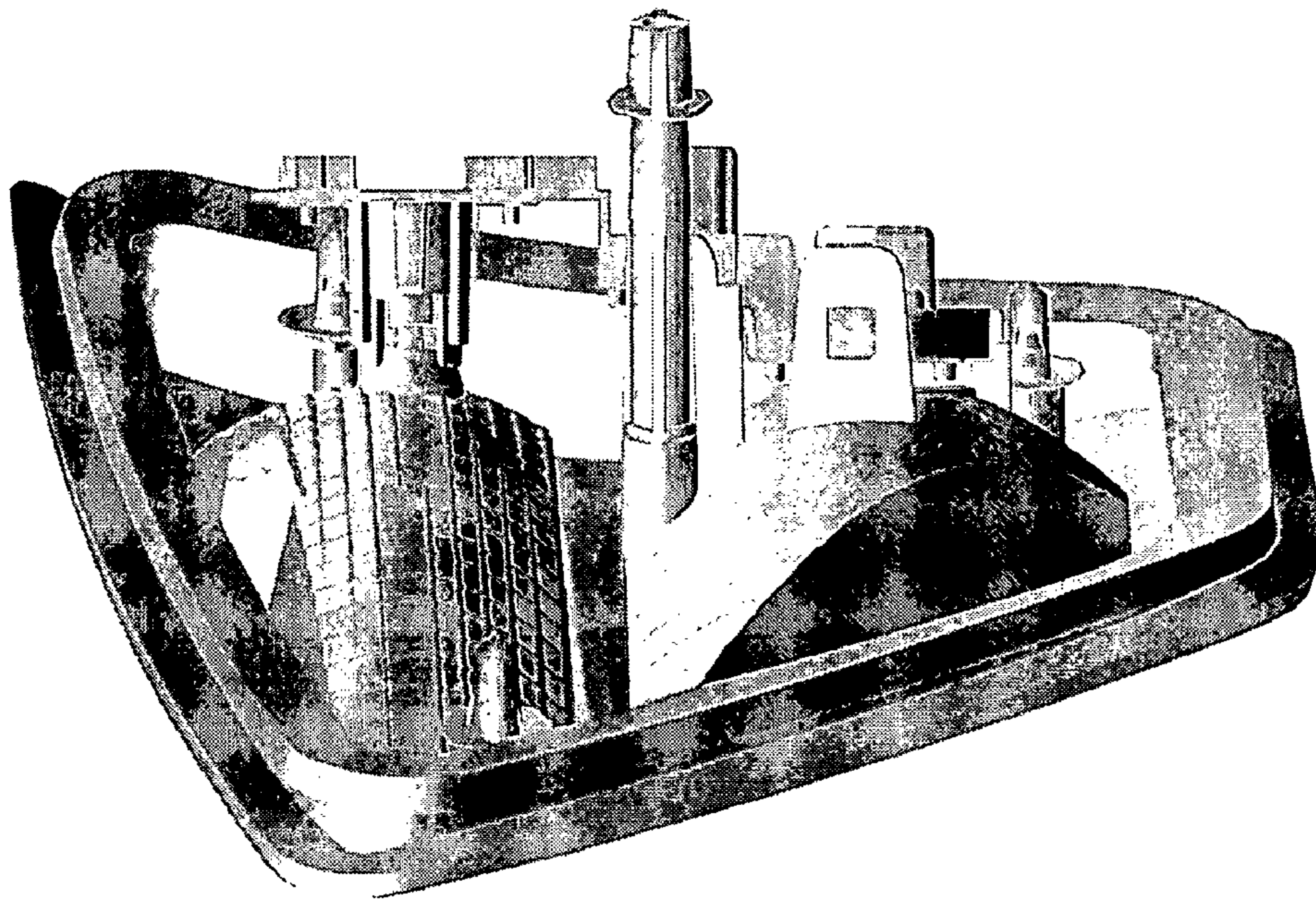

Figure 5

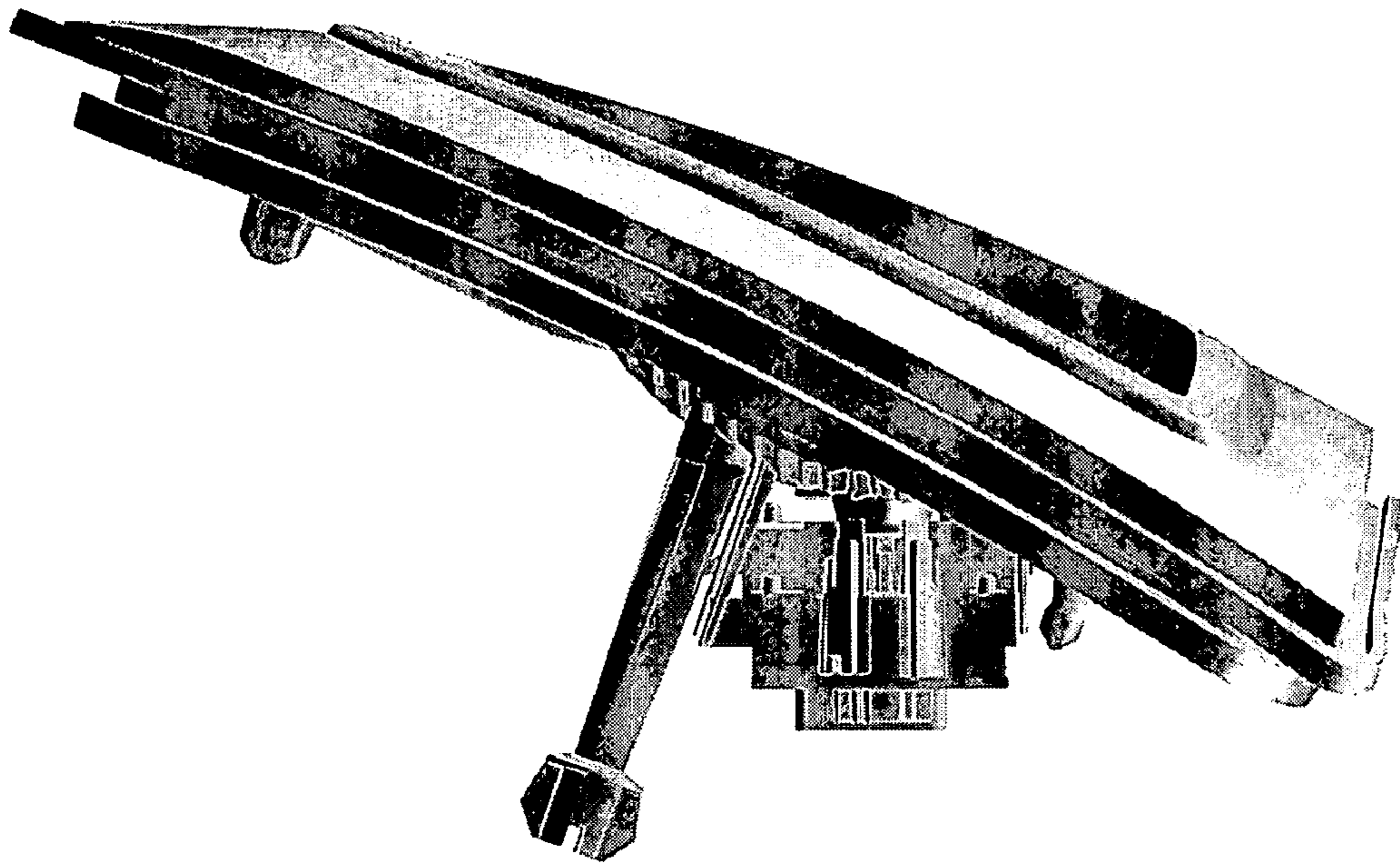

Figure 6

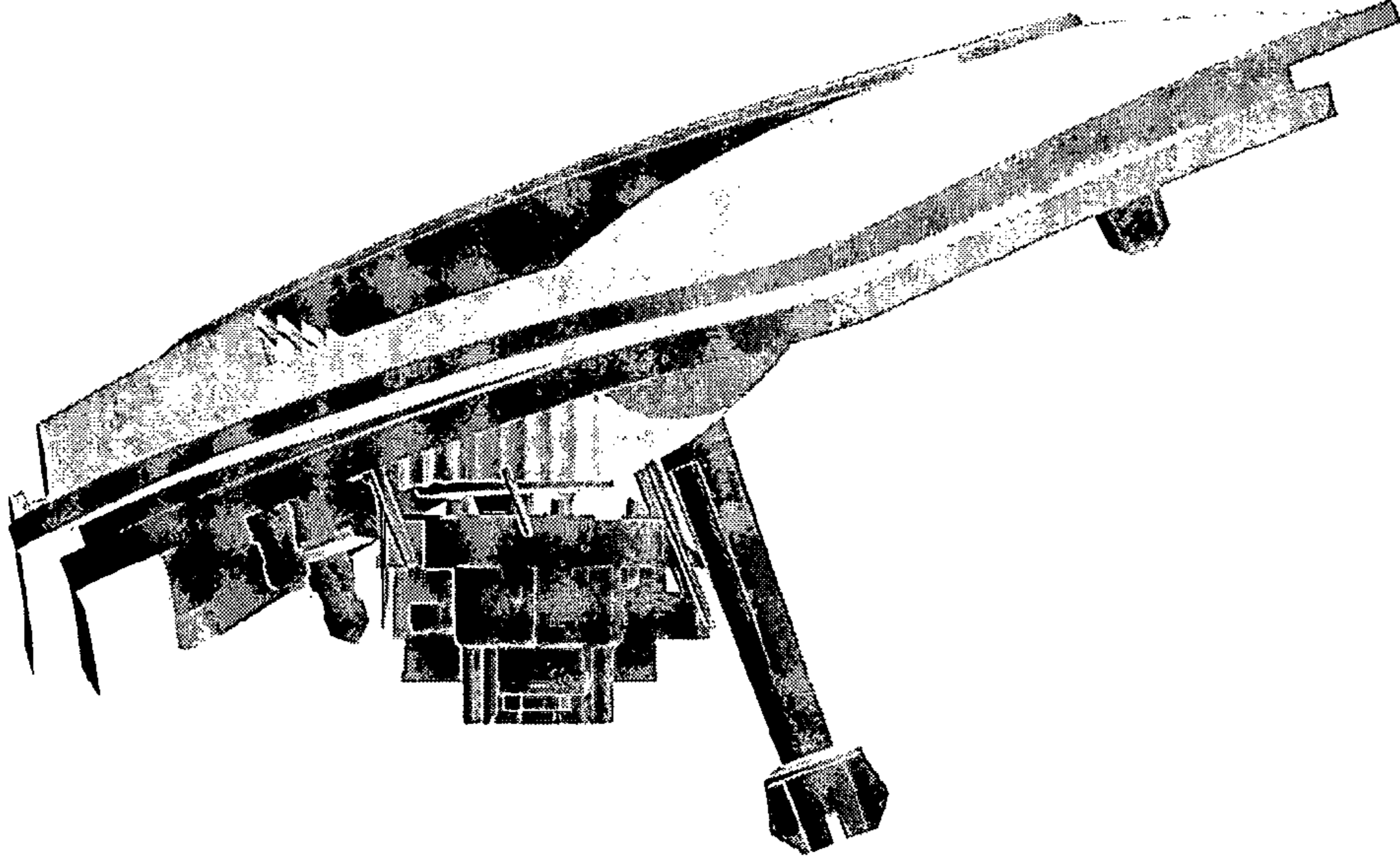

Figure 7

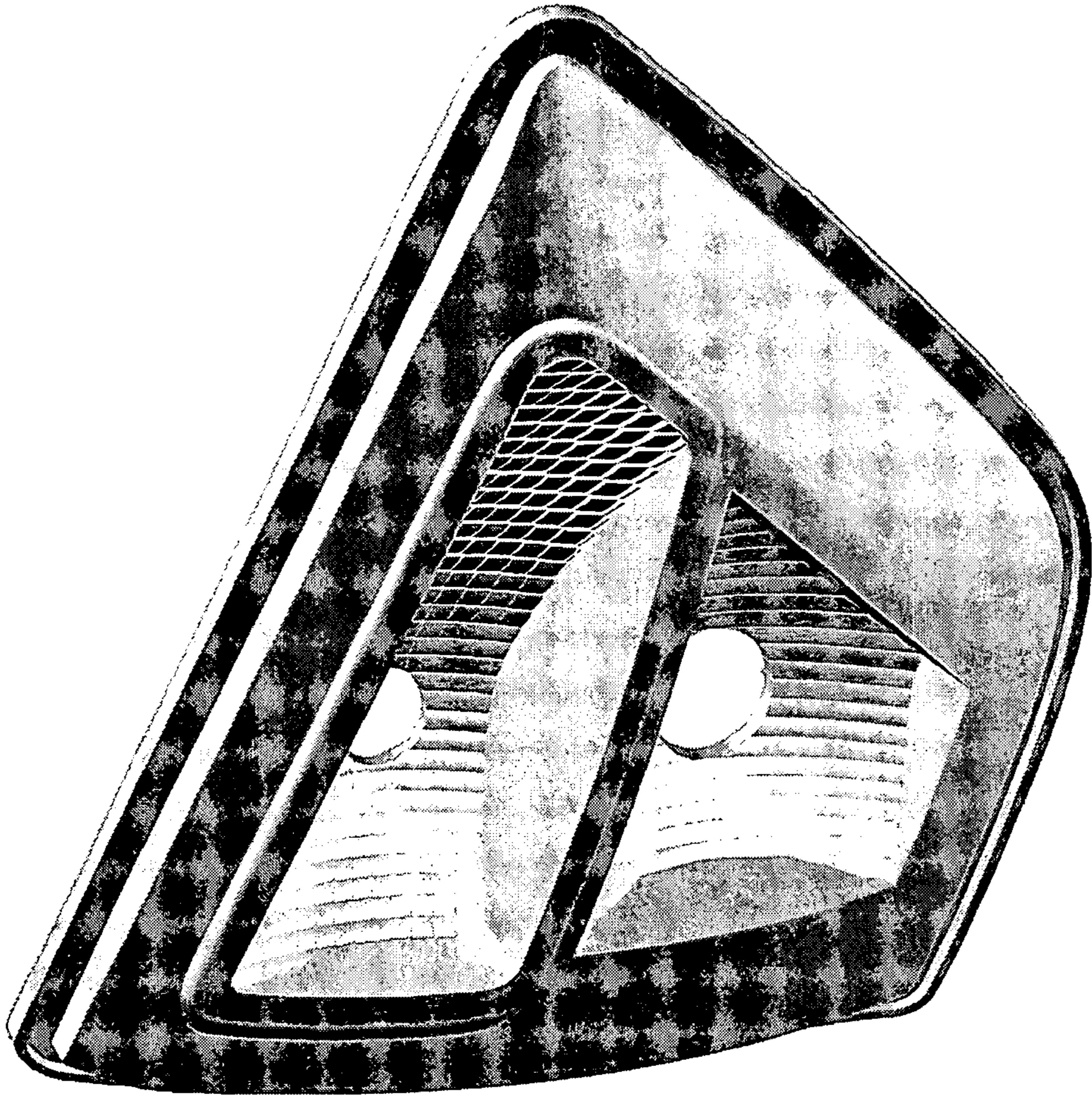

Figure 8

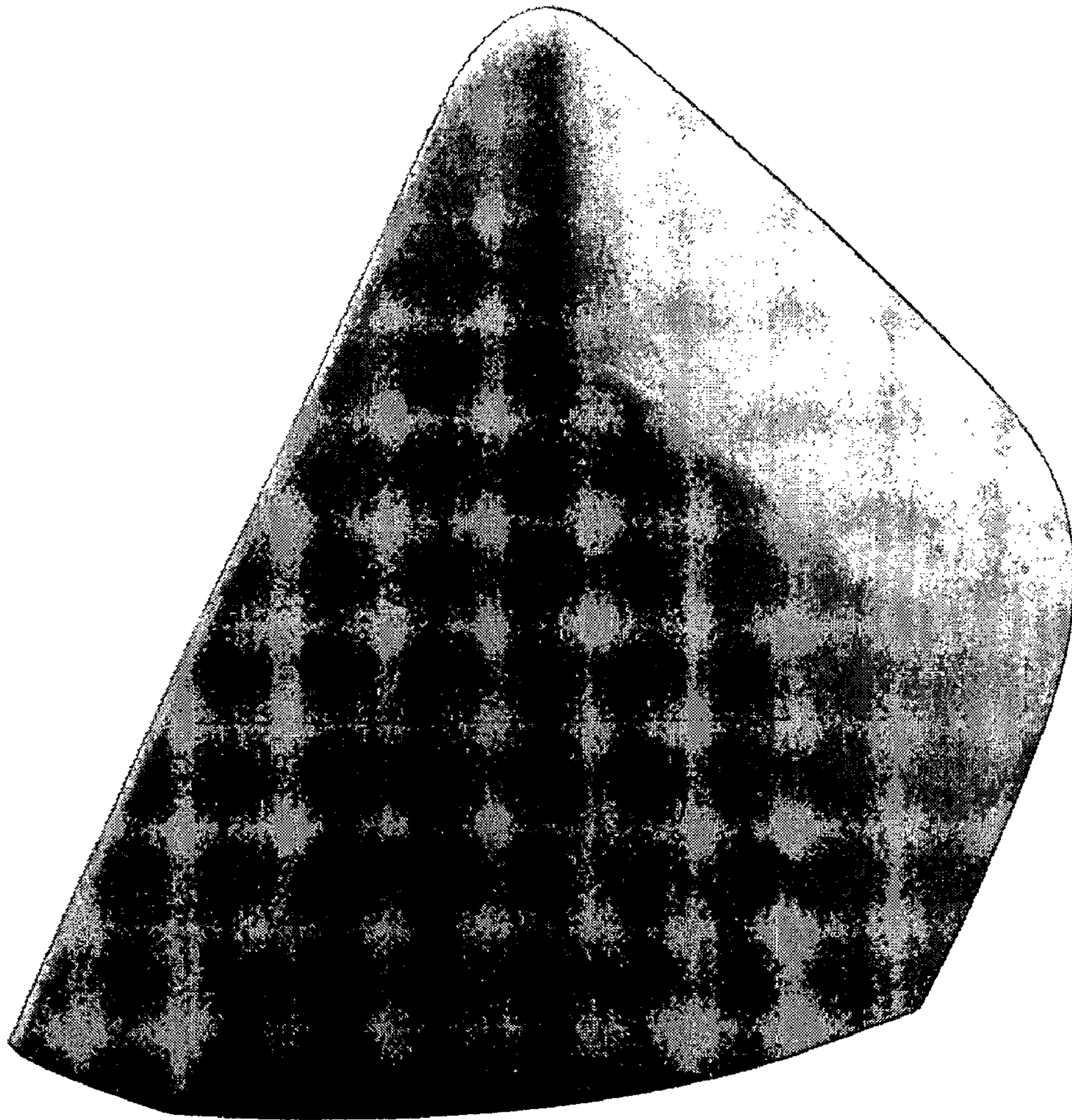

Figure 9