

US00D595604S

(12) **United States Design Patent**  
**Schmalz et al.**

(10) **Patent No.:** **US D595,604 S**  
(45) **Date of Patent:** **\*\* Jul. 7, 2009**

(54) **VACANCY SENSOR**

(75) Inventors: **Andrew Peter Schmalz**, Macungie, PA (US); **Gregory Altonen**, Easton, PA (US); **Elliot G. Jacoby**, Glenside, PA (US); **Noel Mayo**, Philadelphia, PA (US)

(73) Assignee: **Lutron Electronics Co., Inc.**, Coopersburg, PA (US)

(\*\*) Term: **14 Years**

(21) Appl. No.: **29/304,935**

(22) Filed: **Mar. 11, 2008**

(51) **LOC (9) Cl.** ..... **10-05**

(52) **U.S. Cl.** ..... **D10/104**

(58) **Field of Classification Search** ..... D10/104, D10/106, 70; 340/584, 567, 541; D13/152, D13/169, 171; 709/217; 174/535; 248/218.4; 455/420; 361/674; 362/431, 432; D14/155; 438/667; 250/353; 323/282; 315/246

See application file for complete search history.

(56) **References Cited**

**U.S. PATENT DOCUMENTS**

D294,231 S *	2/1988	Cameron et al.	.....	D10/106
D307,578 S	5/1990	Carson et al.		
D333,124 S	2/1993	Carson		
D353,798 S	12/1994	Bryde et al.		
D376,130 S	12/1996	Elwell et al.		
D408,792 S *	4/1999	Hwang	.....	D13/171
D409,936 S	5/1999	Baldwin et al.		
D430,055 S *	8/2000	Aiello et al.	.....	D10/106
D435,798 S *	1/2001	Aiello et al.	.....	D10/104
D437,585 S	2/2001	Mayo et al.		
D439,220 S	3/2001	Mayo et al.		
D439,853 S *	4/2001	Aiello et al.	.....	D10/104
D450,043 S *	11/2001	Mosebrook	.....	D13/171
D503,929 S *	4/2005	Akinrele et al.	.....	D13/171
D511,751 S *	11/2005	Fort et al.	.....	D13/169
D534,875 S *	1/2007	Wu	.....	D13/169
D535,204 S	1/2007	Bender et al.		
D537,046 S	2/2007	Blair et al.		

D539,234 S	3/2007	Blair et al.		
D539,758 S	4/2007	Blair et al.		
D543,158 S *	5/2007	Blair et al.	.....	D13/162
D543,951 S	6/2007	Blair et al.		
D546,293 S *	7/2007	Mayo et al.	.....	D13/162
D546,296 S	7/2007	Blair et al.		
7,319,389 B1 *	1/2008	Mudge	.....	340/541
D565,983 S *	4/2008	Ni et al.	.....	D10/104
D565,984 S *	4/2008	Lidong et al.	.....	D10/104
7,365,282 B2	4/2008	Altonen et al.		
D569,284 S *	5/2008	Ni et al.	.....	D10/70
D569,291 S *	5/2008	Ni et al.	.....	D10/104
D583,688 S *	12/2008	Guercio	.....	D10/70
2006/0267566 A1 *	11/2006	Williams et al.	.....	323/282
2008/0258644 A1 *	10/2008	Altonen et al.	.....	315/246

**OTHER PUBLICATIONS**

- Leviton Manufacturing Co., Inc., Occupancy Sensors Product Guide, 2006, front cover, p. 9, rear cover.
- Leviton Manufacturing Co., Inc., OSSMT-MDA Product Specifications/Info Sheet, 2007, 2 pages.
- Leviton Manufacturing Co., Inc., OSSNL/OSS10 Application Note, 2007, 2 pages.
- Lightolier Controls, IntelliSight Two-Wire Universal Sensor Switch Product Specifications, 2006, 2 pages.
- Lightolier Controls, IntelliSight Universal Sensor Switch Installation and Operations Manual, 2007, 12 pages.
- Lithonia Lighting, LIRW DS Infrared Dual Switch Wall-Mount Sensor Specification Sheet, 1995, 2 pages.
- GE Total Lighting Control, Remote Control Low Voltage Switching Components and Applications, Sep. 1998, front cover, p. 26, rear cover.
- Novitas, Inc., SuperSwitch Mini Automatic On/Manual On Wall Switch Specification Sheet, 2002, 2 pages.
- Novitas, Inc., Super Switch 2 Automatic Dual-Level Self-Adjusting Wall Switch Specification Sheet, 2004, 2 pages.
- Honeywell Security & Custom Electronics, 5800 Series Sensors Brochure, Nov. 2006, 4 pages.
- Honeywell Security & Custom Electronics, 5897-35 Wireless Dual Tec Motion Sensor Specification Sheet, Aug. 2006, 1 page.
- Pass & Seymour, Sensors and Timers Brochure, Nov. 2007, 8 pages.
- Pass & Seymour, Homeowner's Guide to Better Electrical, Jan. 2006, pp. 3, 17, 29, rear cover.
- Pass & Seymour, Advanced Functionality Lighting Controls Brochure, May 2002, front cover, p. 9, rear cover.
- RAB Lighting, LOS800 Smart Switch Occupancy Sensor Installation Manual, 2005, 9 pages.

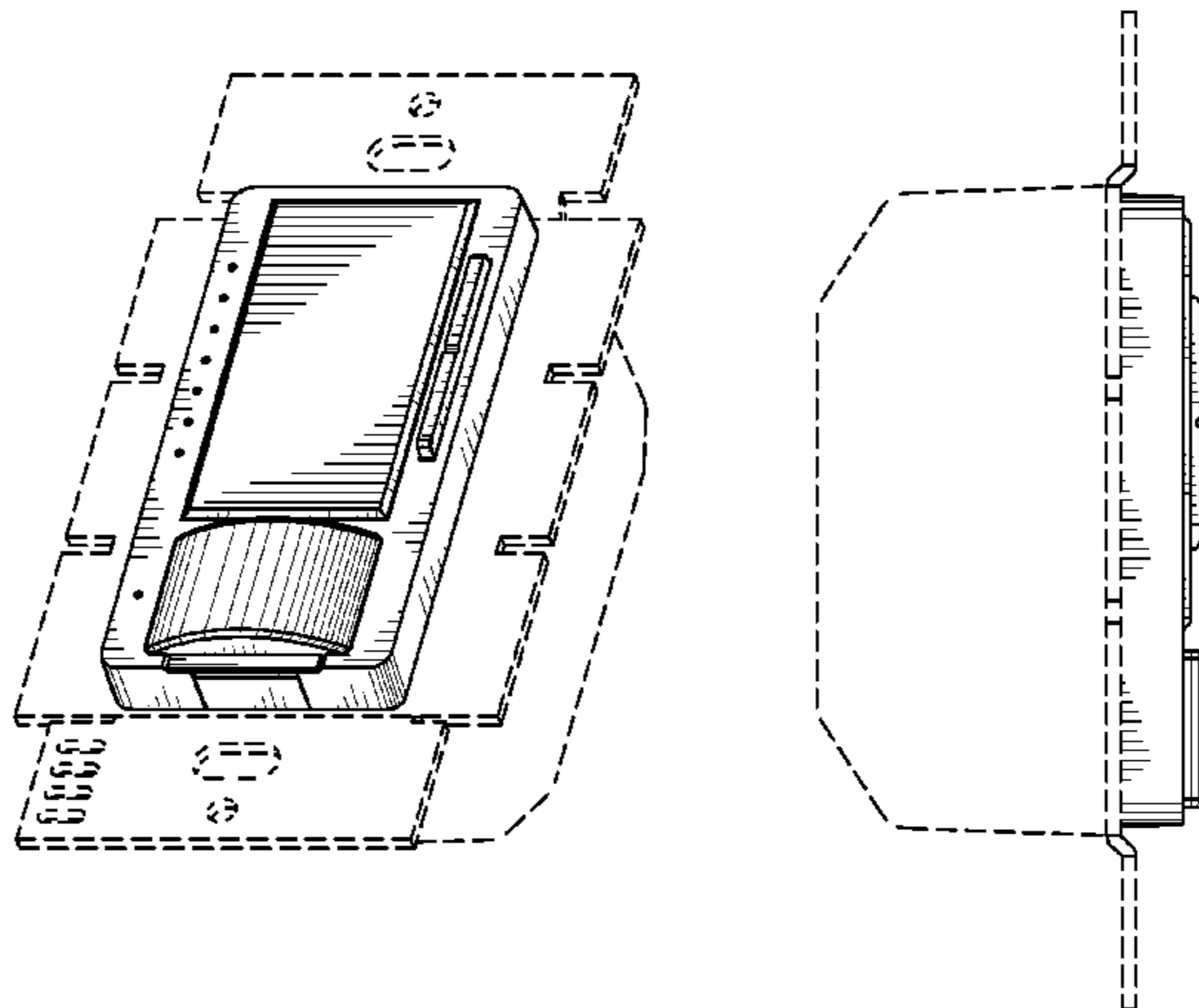

Sensor Switch, Inc., IPD Series 2-Wire Passive Infrared Decorator Wall Switch Sensor Specification Sheet, Jan. 18, 2005, 2 pages.

Sensor Switch, Inc., LWS/LWSH Series Large Area Wall Switch Sensor & High-Mount Application Specification Sheet, Jan. 20, 2005, 2 pages.

Sensor Switch, Inc., Night Light Passive Infrared Switch Sensor Specification Sheet, Dec. 7, 2005, 2 pages.

Sensor Switch, Inc., WSD-PDT 2 Pole Passive Dual Technology Decorator Wall Switch Sensor Specification Sheet, Apr. 28, 2006, 2 pages.

Watt Stopper, DW-100/DW-100-347/DW-200 Dual Technology Wall Switch Occupancy Sensor Installation Instructions, Oct. 2006, 8 pages.

Watt Stopper, PW-100/PW-100-347/PW-200 Passive Infrared Wall Switch Occupancy Sensor Installation Instructions, Oct. 2006, 8 pages.

Watt Stopper, RH-200 Multi-Way Wall Switch Vacancy Sensor Installation Instructions, Sep. 2006, 6 pages.

Watt Stopper, WD-270/WD-280 Dimmable PIR Wall Switch Installation Instructions, Mar. 1998, 4 pages.

Watt Stopper, WN-100 Motion Sensor Nightlight Switch Installation Instructions, May 2008, 7 pages.

Watt Stopper, WS-200 Automatic PIR Wall Switch Installation Instructions, Feb. 2005, 8 pages.

Watt Stopper, WI-300 Dual Relay PIR Wall Switch Installation Instructions, Jun. 2001, 7 pages.

Hubbell Building Automation, Inc., LightHawk Passive Infrared Wall Switch Sensor, Feb. 2006, 2 pages.

Hubbell Building Automation, Inc., LightHawk Multi-Technology Wall Switch Sensor, Feb. 2006, 2 pages.

Lutron Electronics Co., Inc., Passive Infrared Wall Switches Specification Submittal Sheet, Aug. 9, 2005, 6 pages.

\* cited by examiner

*Primary Examiner*—Caron Veynar

*Assistant Examiner*—George D Kirschbaum

(74) *Attorney, Agent, or Firm*—Mark E. Rose; Philip N. Smith

(57) **CLAIM**

We claim the ornamental design for a vacancy sensor, as shown and described.

**DESCRIPTION**

FIG. 1 is a perspective view of a vacancy sensor according to a first embodiment of our new design.

FIG. 2 is a front view thereof.

FIG. 3 is a left side view thereof.

FIG. 4 is a right side view thereof.

FIG. 5 is a top view thereof.

FIG. 6 is a bottom view thereof.

FIG. 7 is a perspective view of a dimmer switch according to a second embodiment of our new design.

FIG. 8 is a front view thereof, the left side, right side, top, and bottom views, respectively, of the second embodiment being identical to the left side, right side, top, and bottom views of the first embodiment.

FIG. 9 is a perspective view of a vacancy sensor according to a third embodiment of our new design.

FIG. 10 is a front view thereof, the left side, right side, top, and bottom views, respectively, of the third embodiment being identical to the left side, right side, top, and bottom views of the first embodiment.

FIG. 11 is a perspective view of a vacancy sensor according to a fourth embodiment of our new design.

FIG. 12 is a front view thereof, the left side, right side, top, and bottom views, respectively, of the fourth embodiment being identical to the left side, right side, top, and bottom views of the first embodiment.

FIG. 13 is a perspective view of a vacancy sensor according to a fifth embodiment of our new design.

FIG. 14 is a front view thereof.

FIG. 15 is a top view thereof.

FIG. 16 is a bottom view thereof, the left side and right side views, respectively, of the fifth embodiment being identical to the left side and right side views of the first embodiment.

FIG. 17 is a perspective view of a vacancy sensor according to a sixth embodiment of our new design.

FIG. 18 is a front view thereof, the left side, right side, top, and bottom views, respectively, of the sixth embodiment being identical to the left side, right side, top, and bottom views of the fifth embodiment.

FIG. 19 is a perspective view of a vacancy sensor according to a seventh embodiment of our new design.

FIG. 20 is a front view thereof, the left side, right side, top, and bottom views, respectively, of the seventh embodiment being identical to the left side, right side, top, and bottom views of the fifth embodiment.

FIG. 21 is a perspective view of a vacancy sensor according to an eighth embodiment of our new design.

FIG. 22 is a front view thereof, the left side, right side, top, and bottom views, respectively, of the eighth embodiment being identical to the left side, right side, top, and bottom views of the fifth embodiment.

FIG. 23 is a perspective view of a vacancy sensor according to a ninth embodiment of our new design.

FIG. 24 is a front view thereof.

FIG. 25 is a left side view thereof.

FIG. 26 is a right side view thereof.

FIG. 27 is a top view thereof.

FIG. 28 is a bottom view thereof.

FIG. 29 is a perspective view of a dimmer switch according to a tenth embodiment of our new design.

FIG. 30 is a front view thereof, the left side, right side, top, and bottom views, respectively, of the tenth embodiment being identical to the left side, right side, top, and bottom views of the ninth embodiment.

FIG. 31 is a perspective view of a vacancy sensor according to an eleventh embodiment of our new design.

FIG. 32 is a front view thereof, the left side, right side, top, and bottom views, respectively, of the eleventh embodiment being identical to the left side, right side, top, and bottom views of the ninth embodiment.

FIG. 33 is a perspective view of a vacancy sensor according to a twelfth embodiment of our new design.

FIG. 34 is a front view thereof, the left side, right side, top, and bottom views, respectively, of the twelfth embodiment being identical to the left side, right side, top, and bottom views of the ninth embodiment.

FIG. 35 is a perspective view of a vacancy sensor according to a thirteenth embodiment of our new design.

FIG. 36 is a front view thereof.

FIG. 37 is a top view thereof.

FIG. 38 is a bottom view thereof, the left side and right side views, respectively, of the thirteenth embodiment being identical to the left side and right side views of the ninth embodiment.

FIG. 39 is a perspective view of a vacancy sensor according to a fourteenth embodiment of our new design.

FIG. 40 is a front view thereof, the left side, right side, top, and bottom views, respectively, of the fourteenth embodiment being identical to the left side, right side, top, and bottom views of the thirteenth embodiment.

FIG. 41 is a perspective view of a vacancy sensor according to a fifteenth embodiment of our new design.

FIG. 42 is a front view thereof, the left side, right side, top, and bottom views, respectively, of the fifteenth embodiment being identical to the left side, right side, top, and bottom views of the thirteenth embodiment.

FIG. 43 is a perspective view of a vacancy sensor according to a sixteenth embodiment of our new design; and,

FIG. 44 is a front view thereof, the left side, right side, top, and bottom views, respectively, of the sixteenth embodiment being identical to the left side, right side, top, and bottom views of the thirteenth embodiment.

The rear views form no part of the design and are omitted. The portions of the drawings appearing in broken line are for environment only and do not form a part of the claimed design.

**1 Claim, 38 Drawing Sheets**

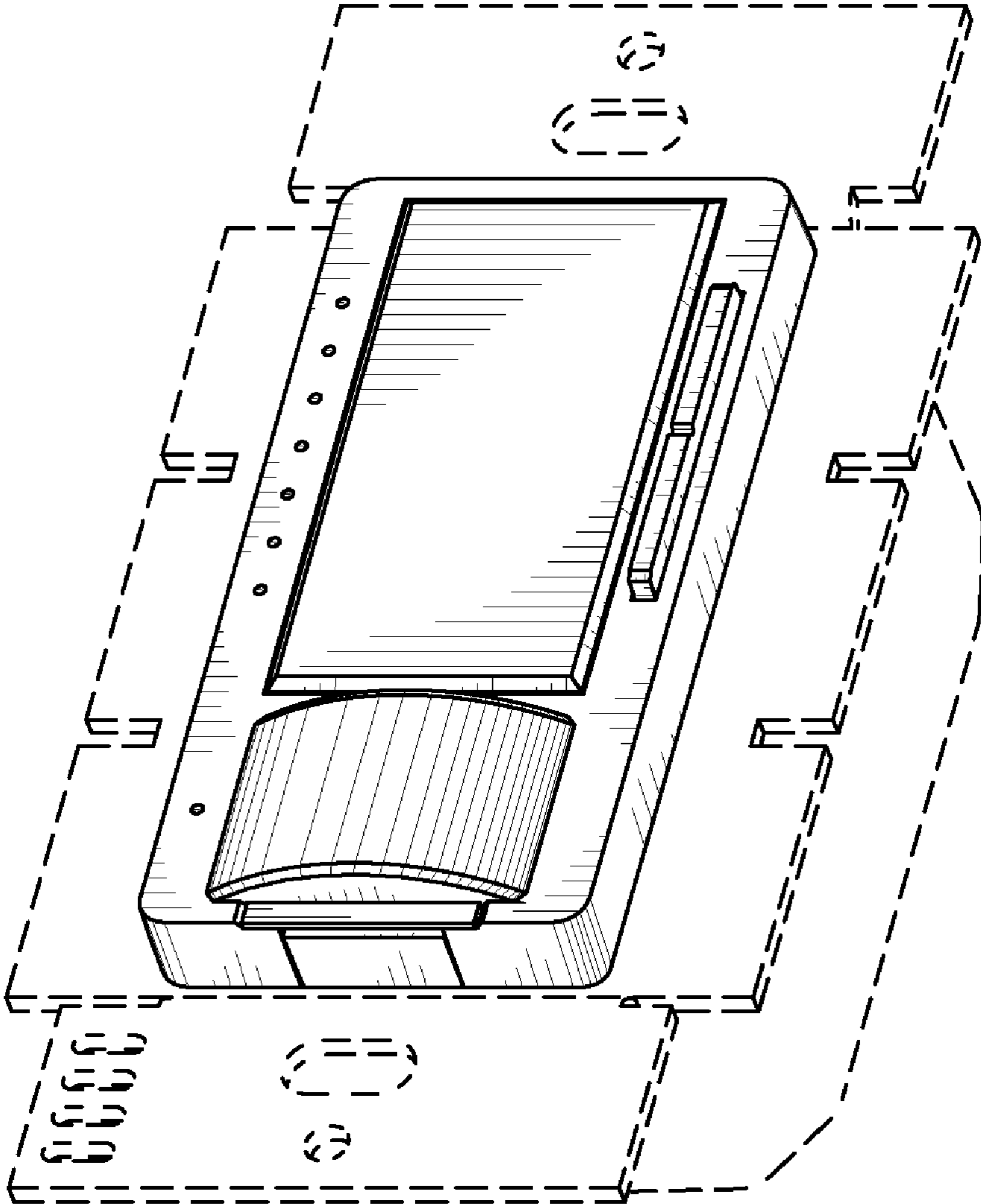

Fig. 1

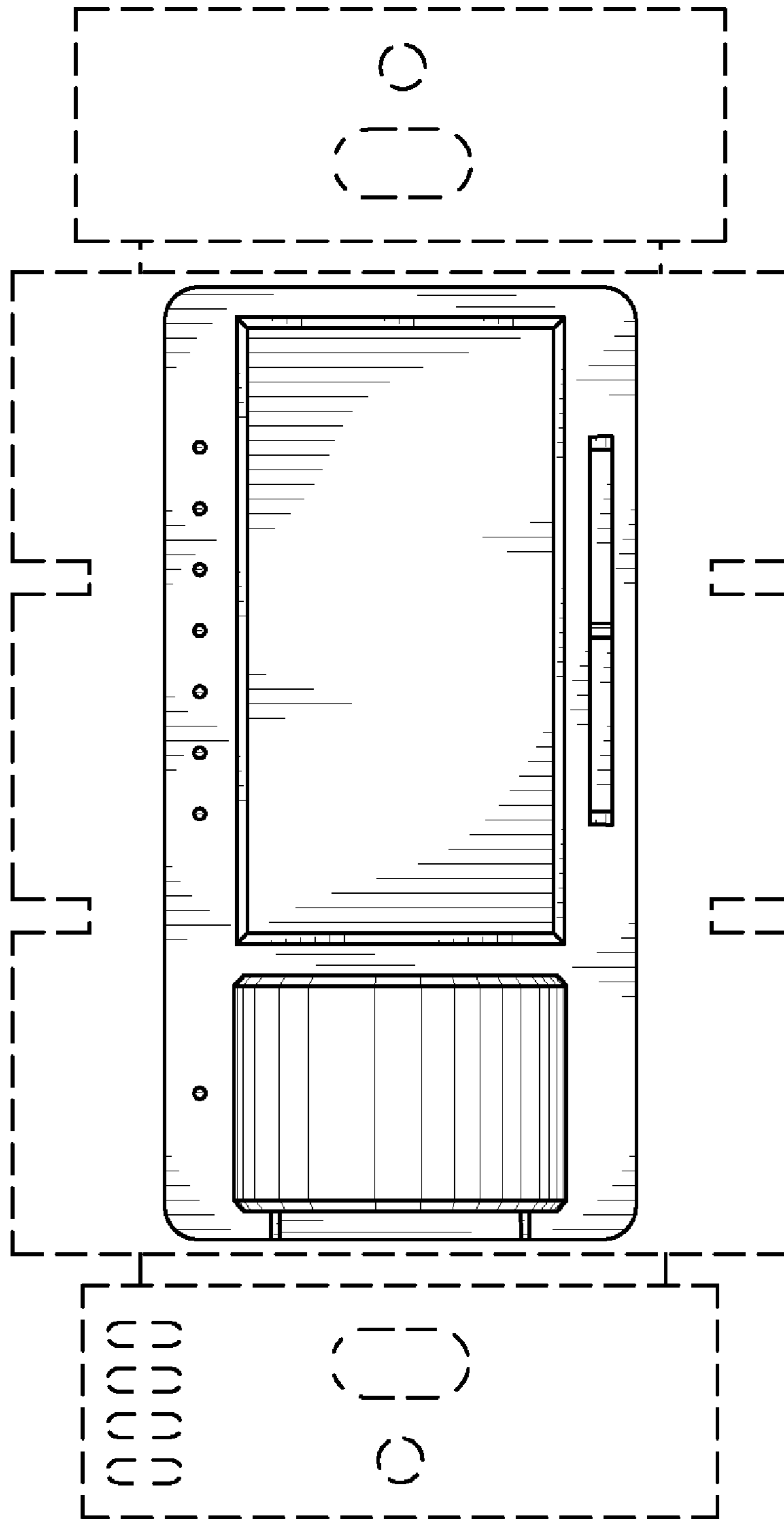

Fig. 2

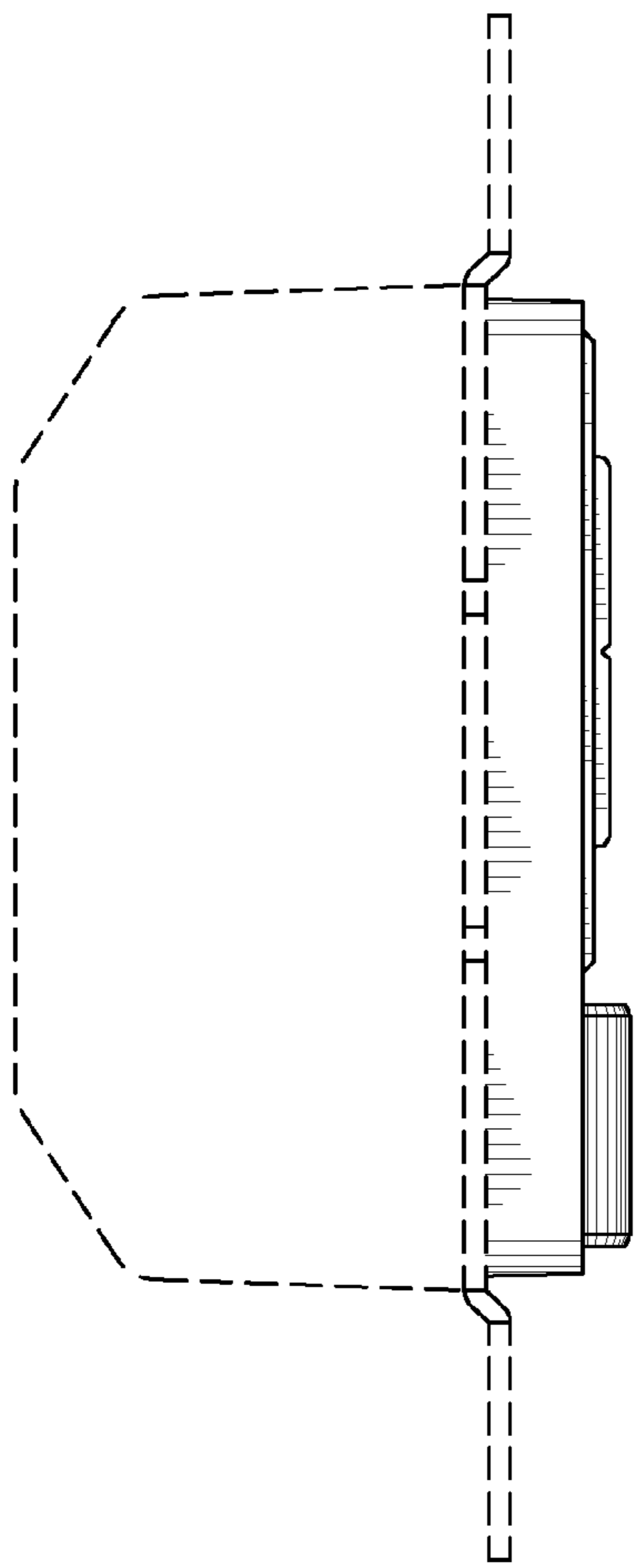

Fig. 3

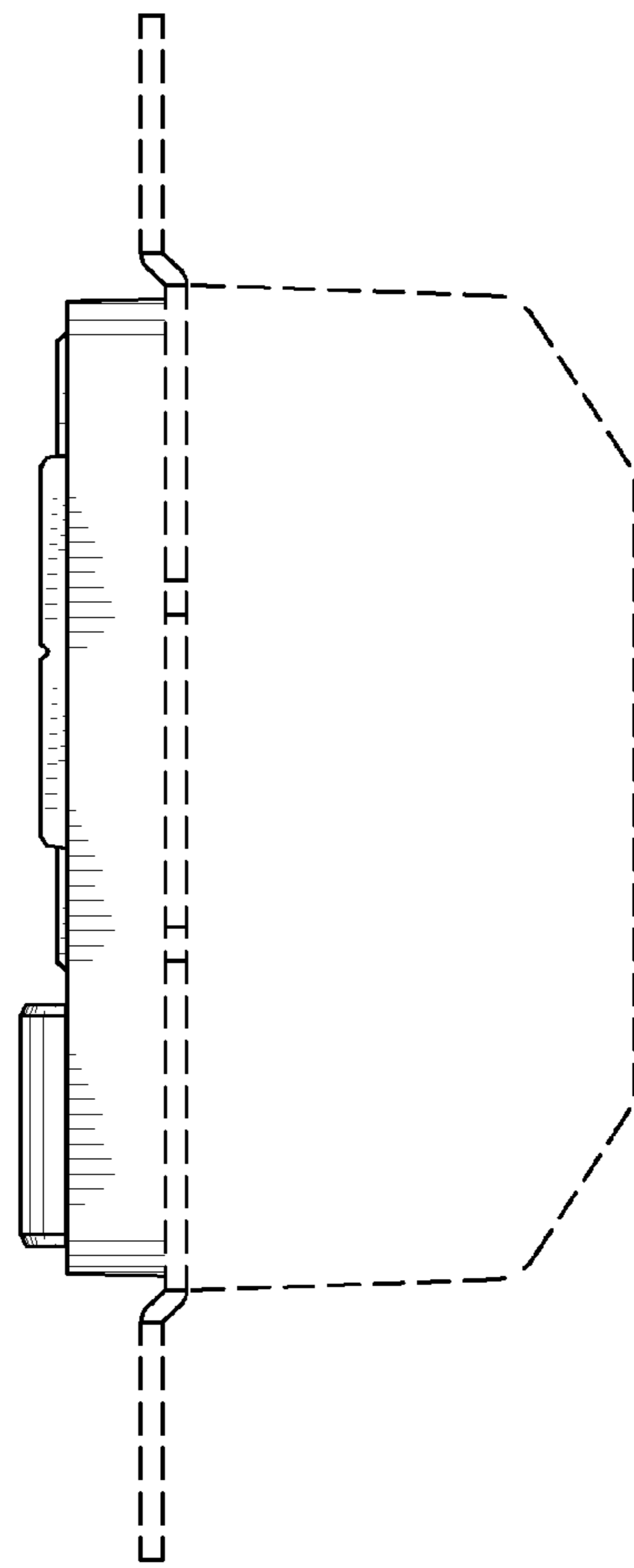

Fig. 4

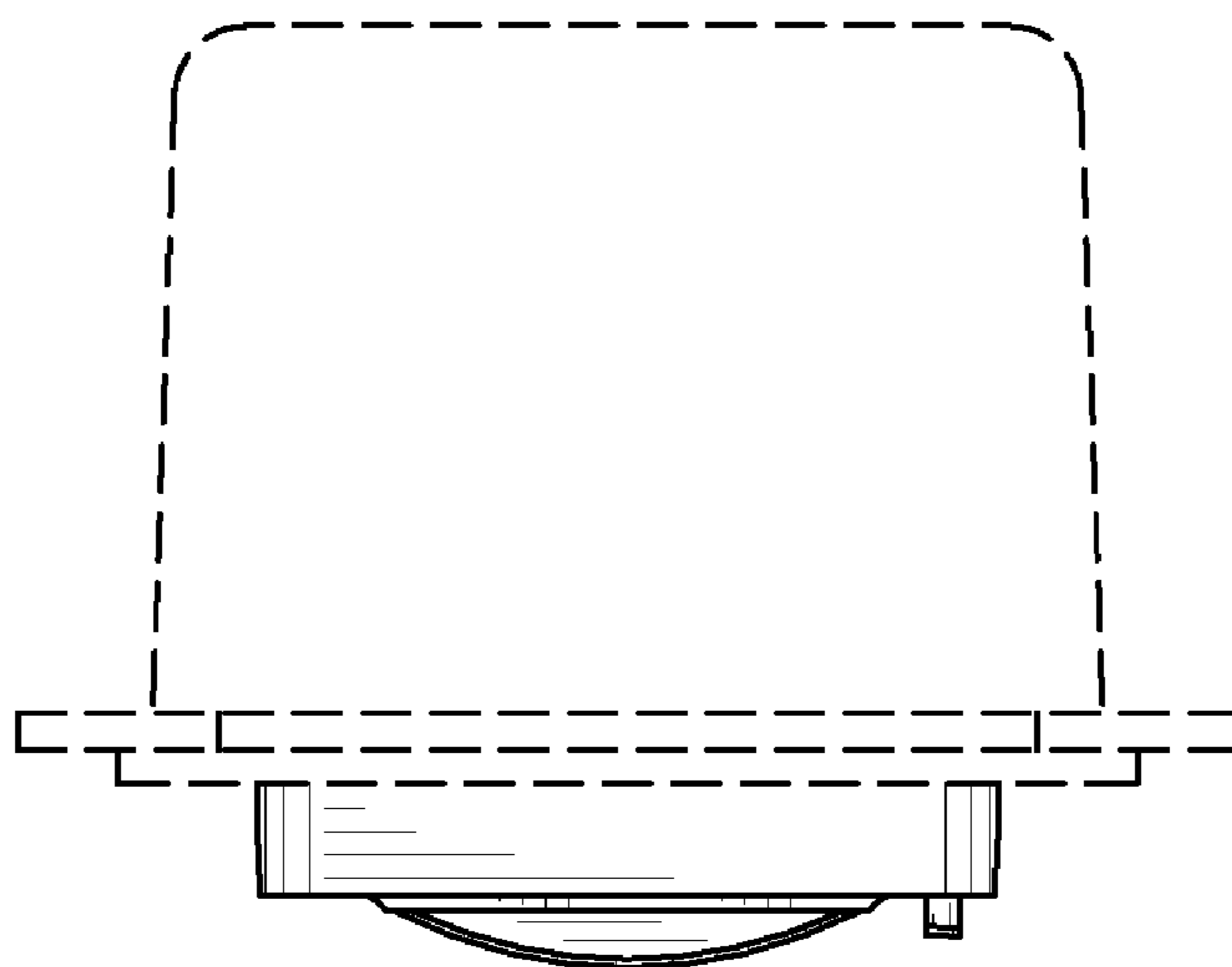

Fig. 5

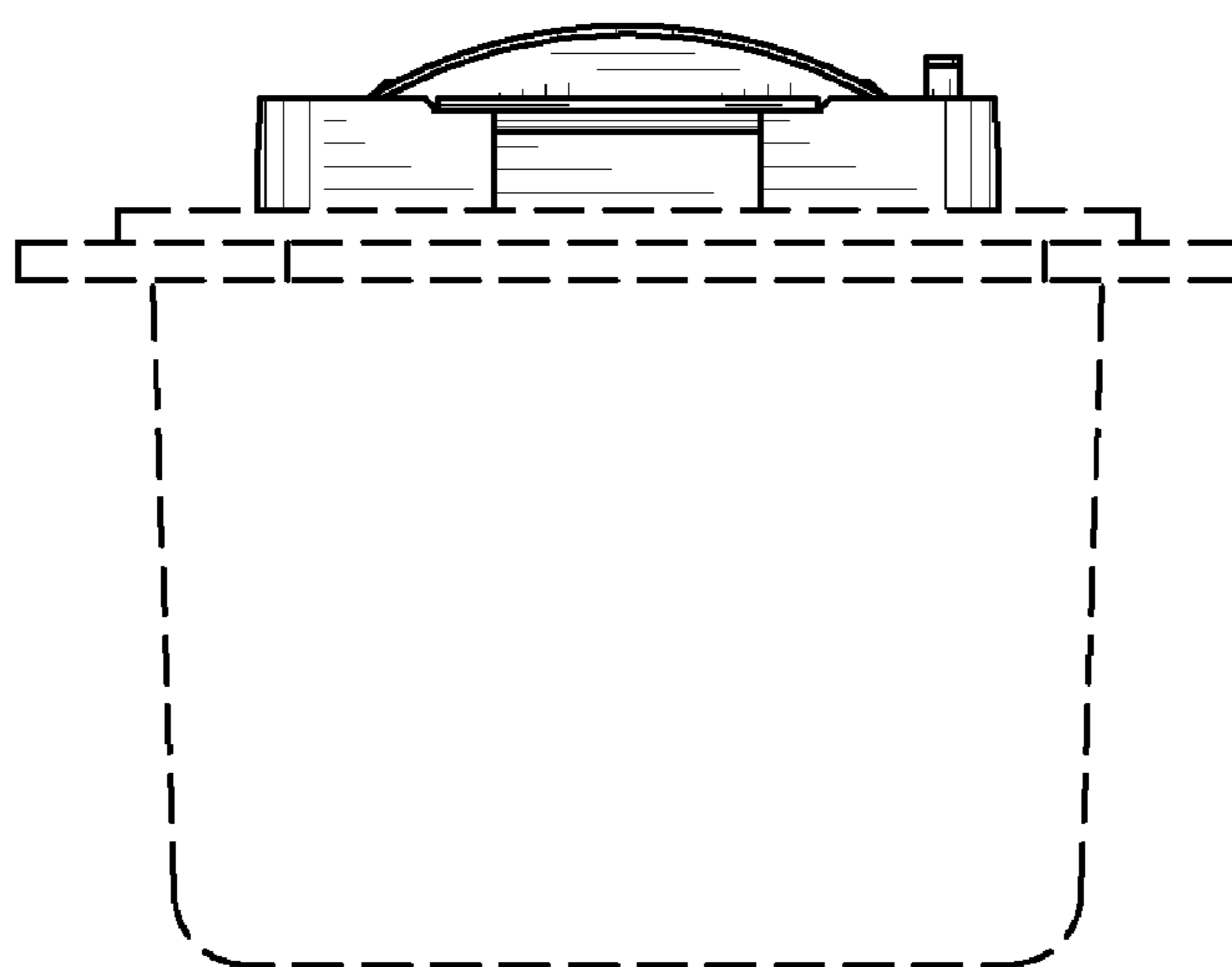

Fig. 6

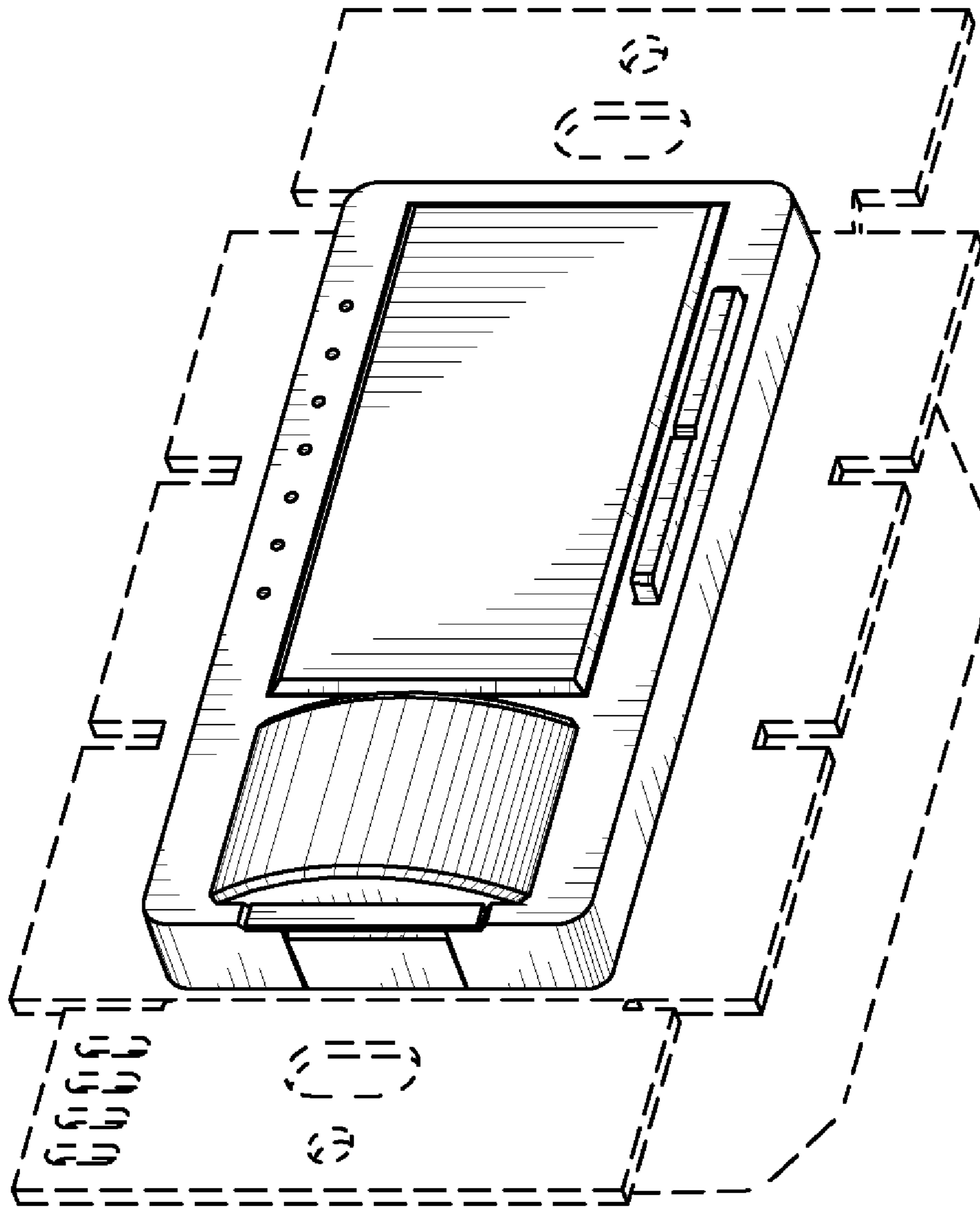

Fig. 7



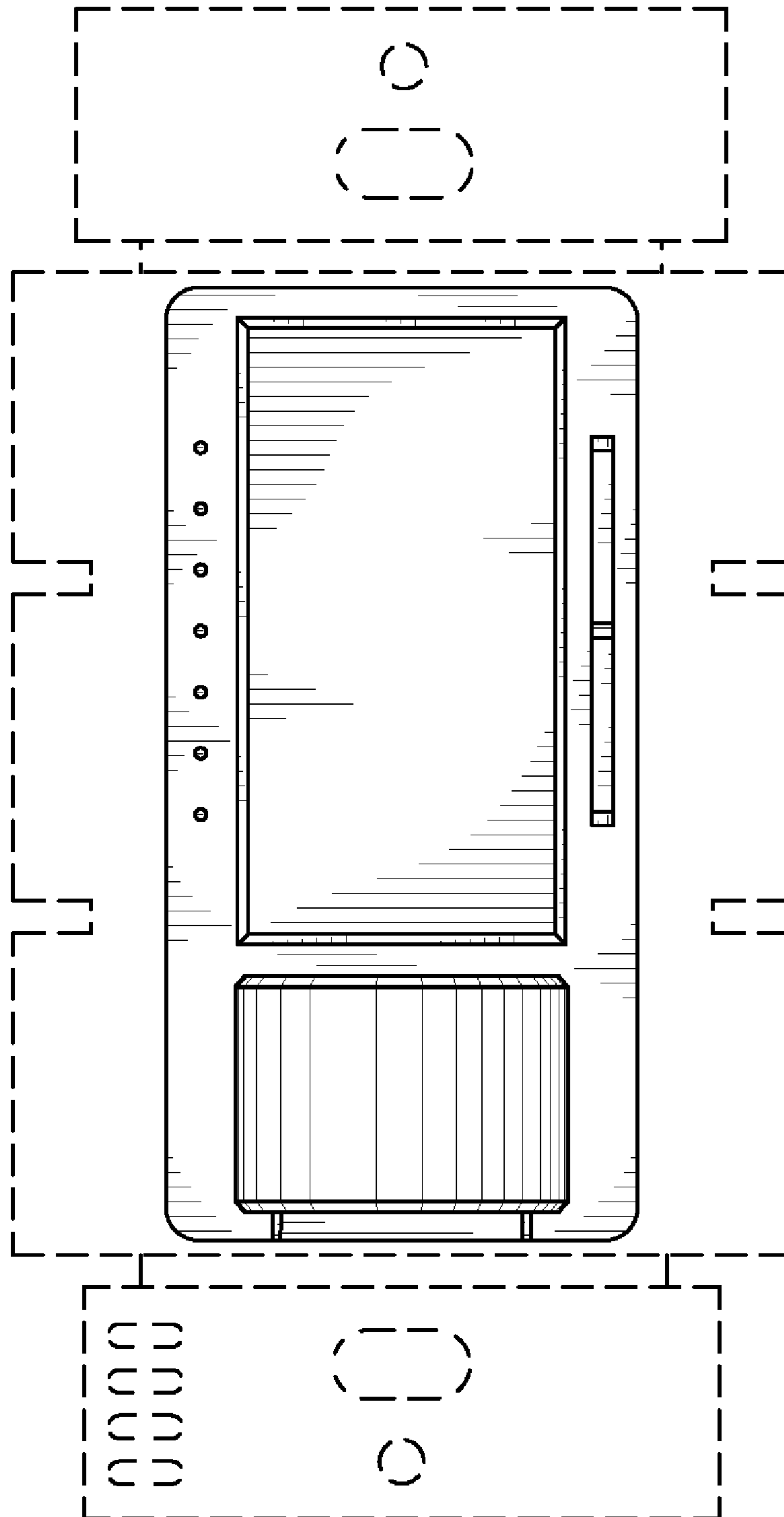

Fig. 8

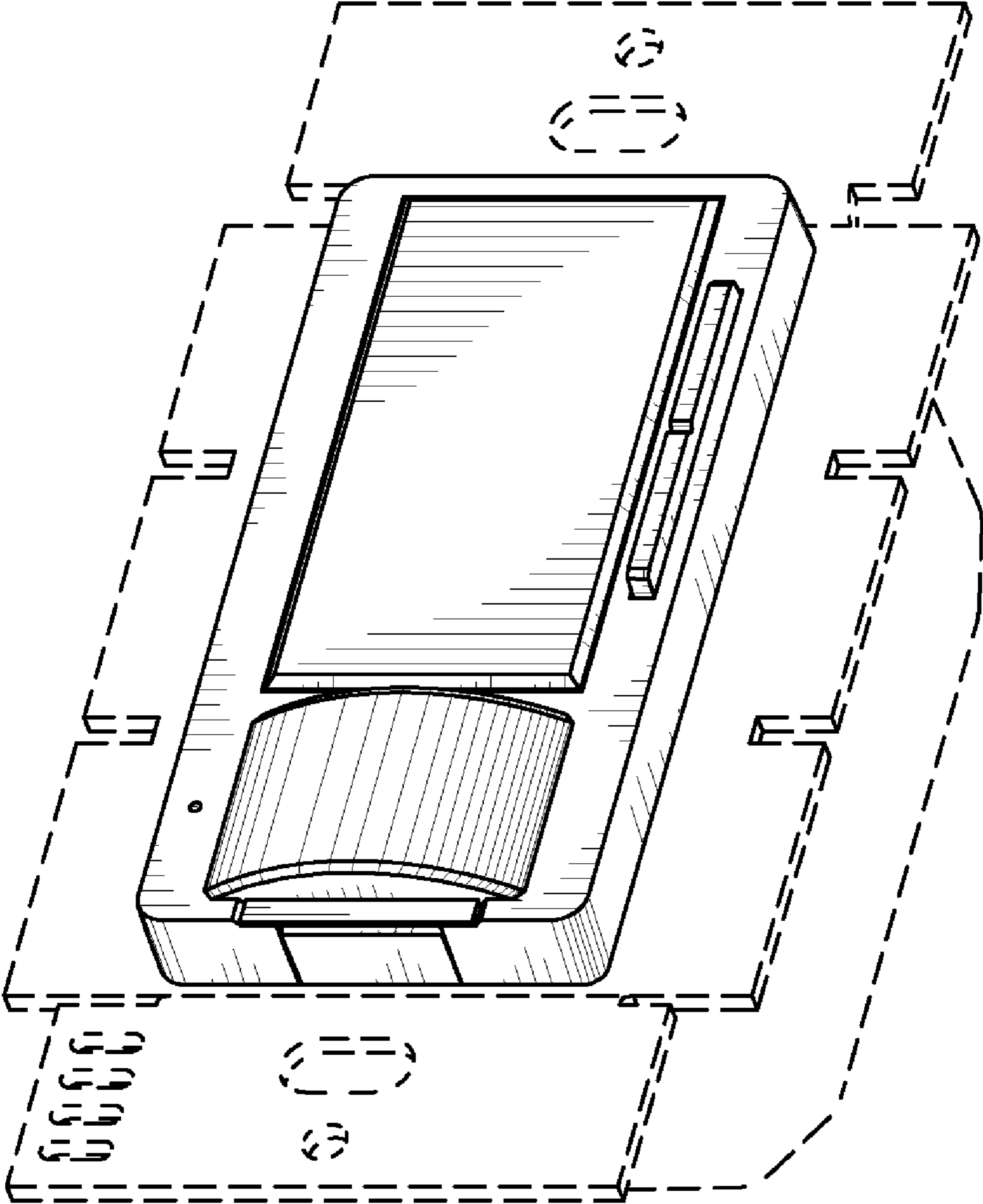

Fig. 9

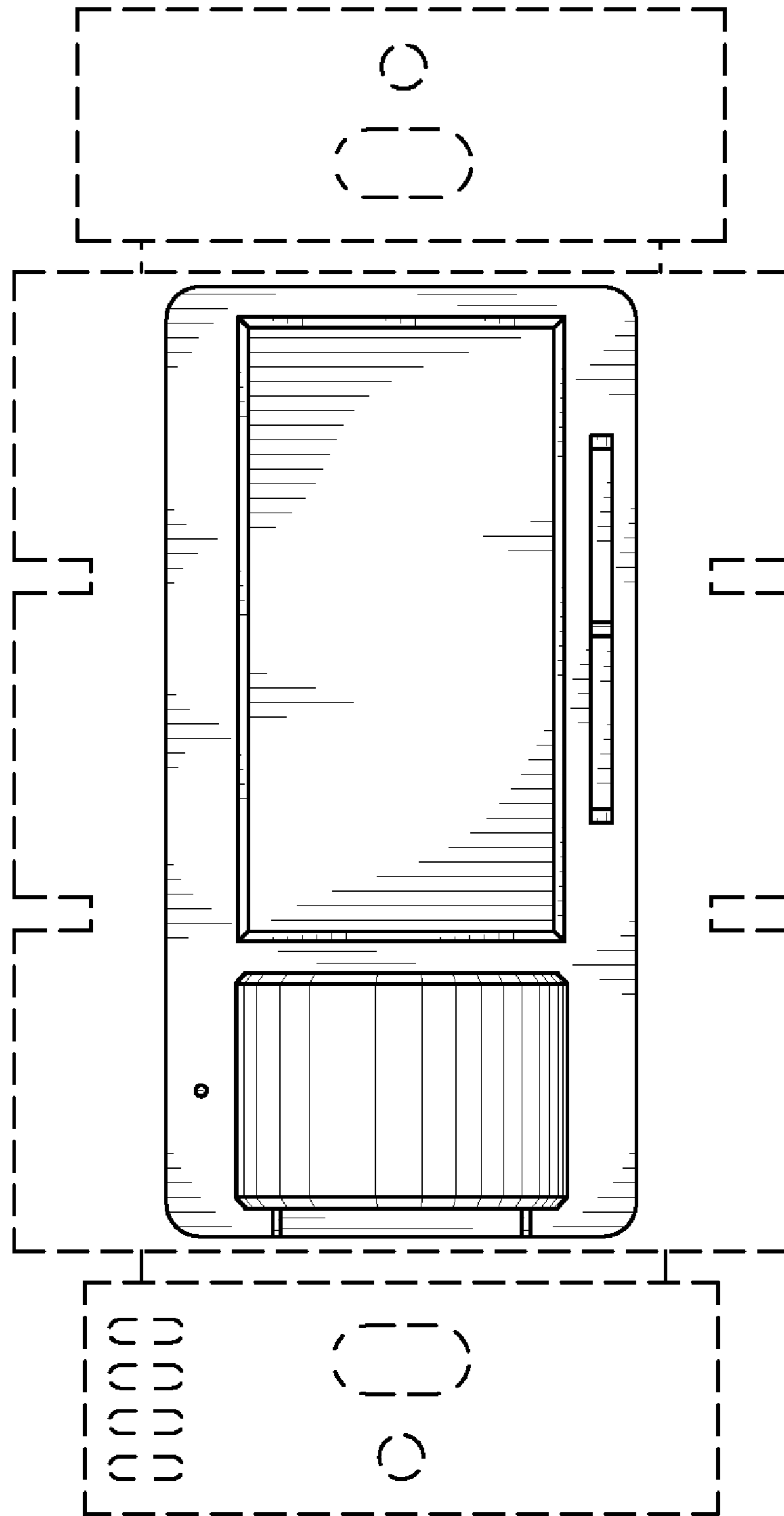

Fig. 10

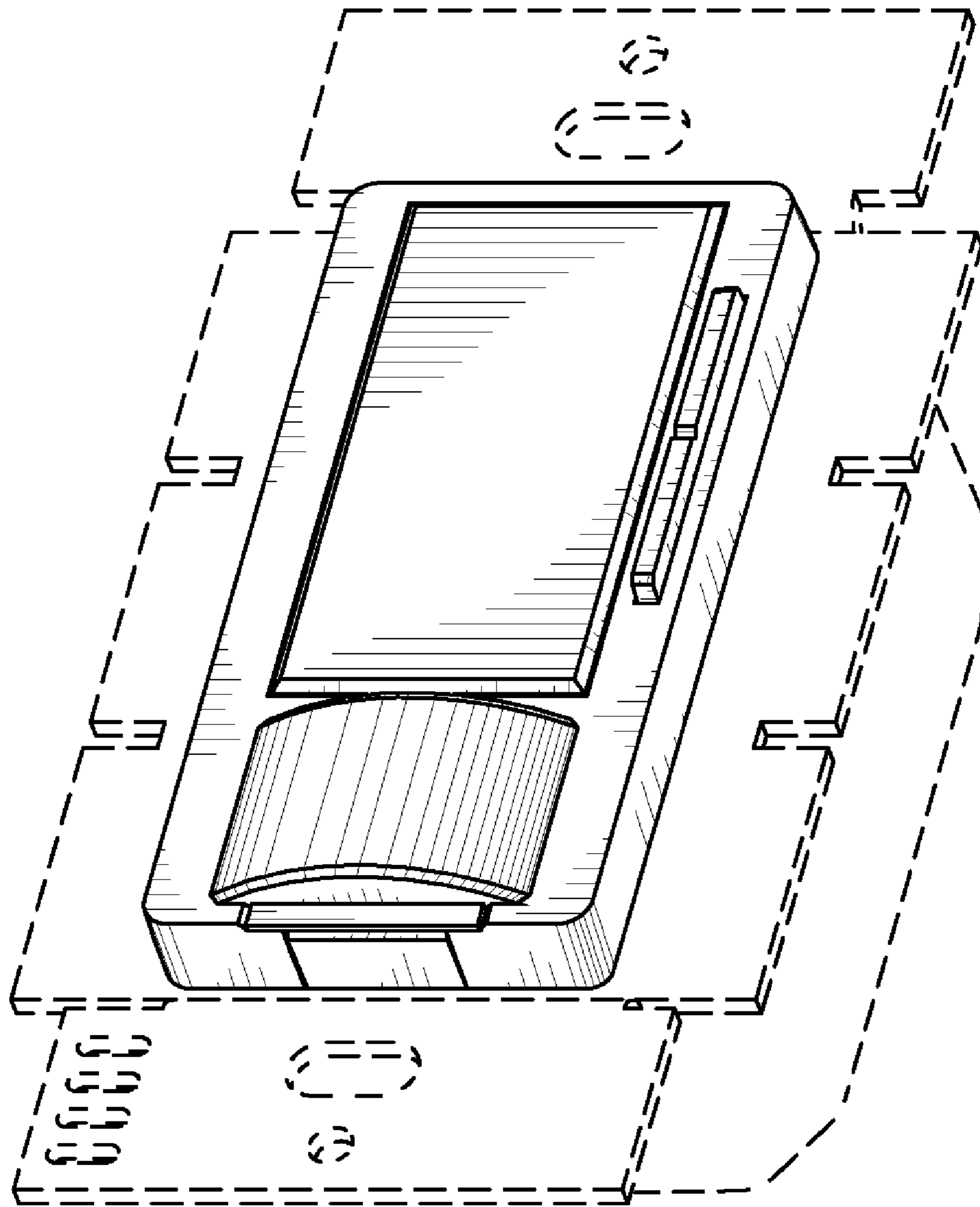

Fig. 11

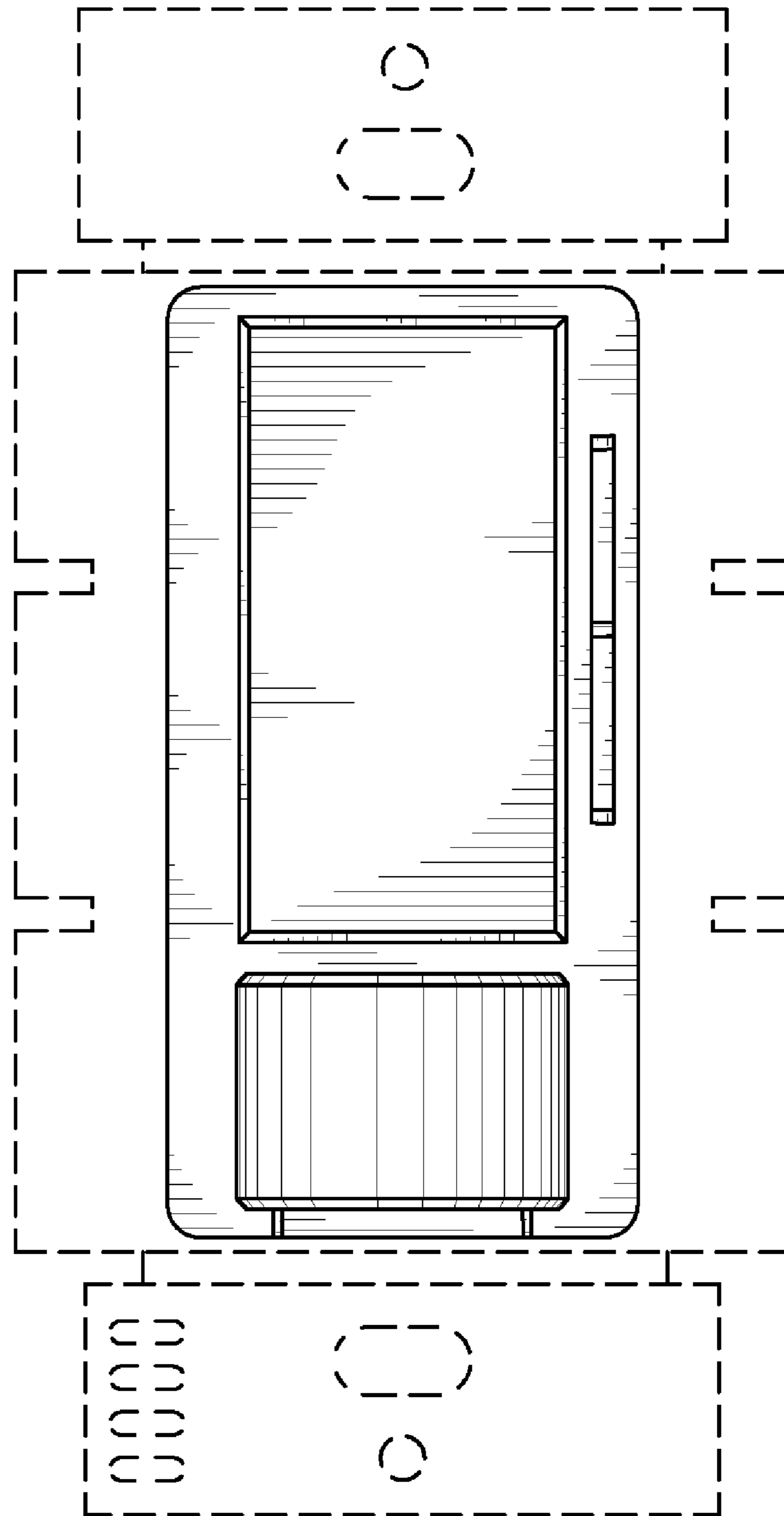

Fig. 12

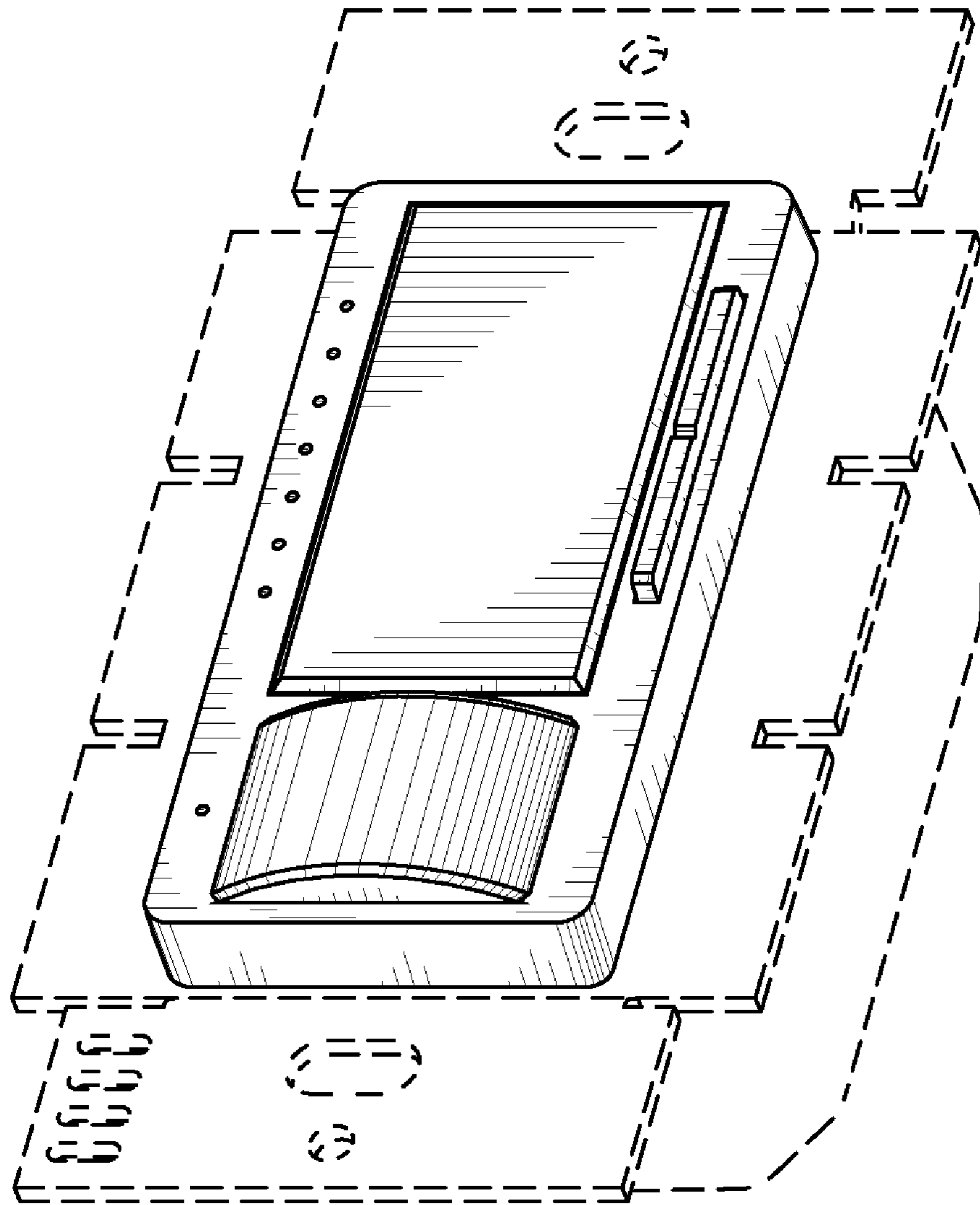

Fig. 13

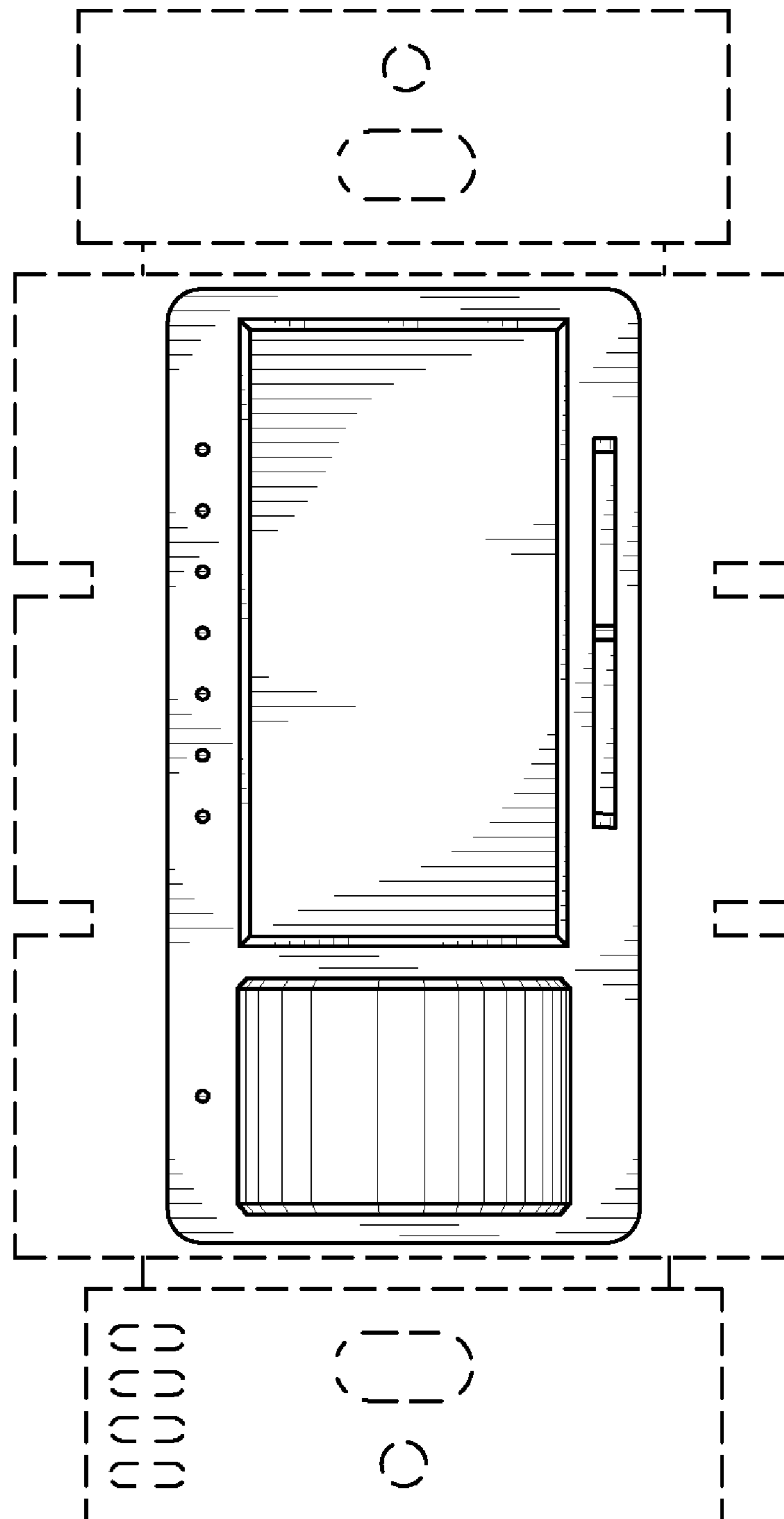

Fig. 14

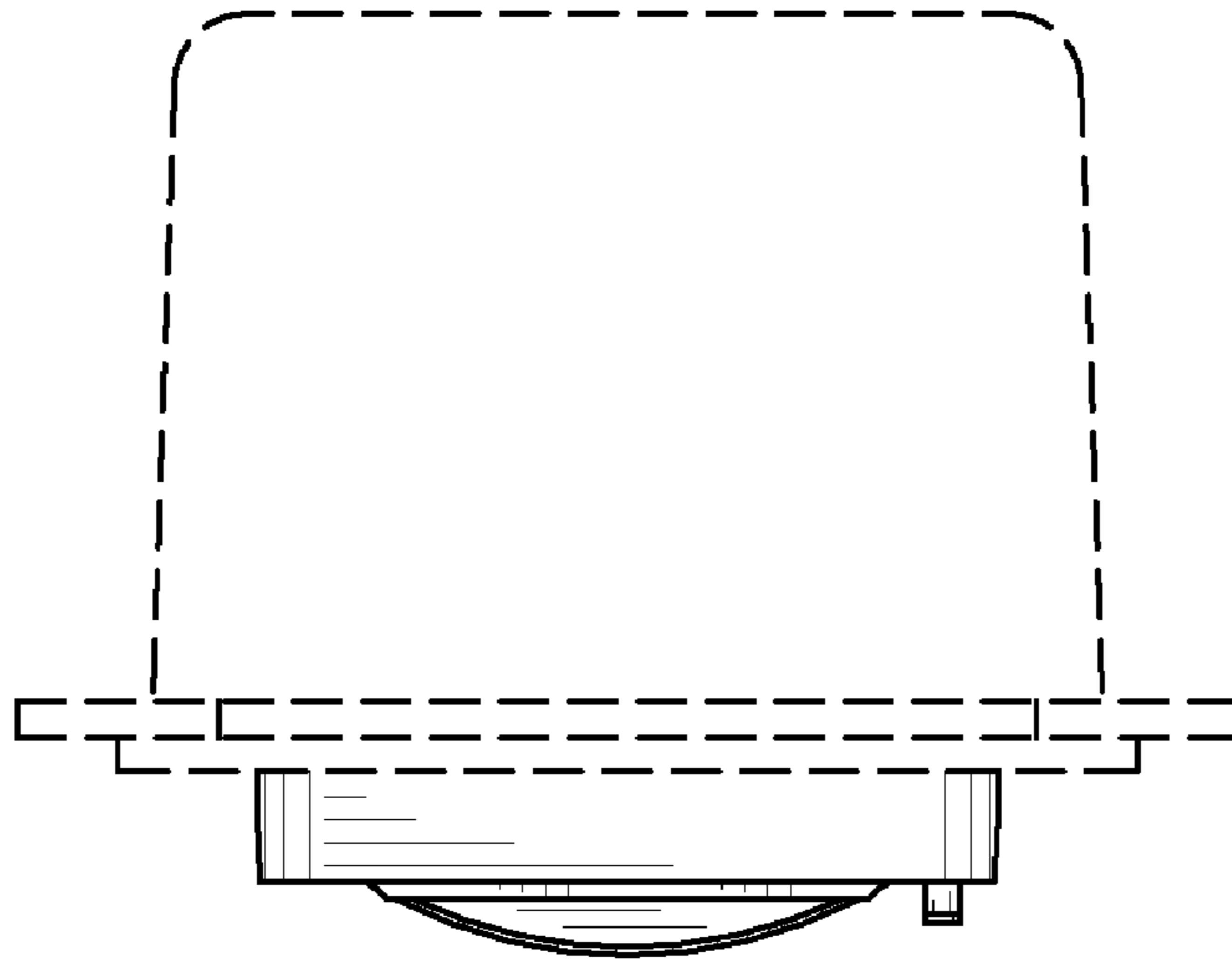

Fig. 15

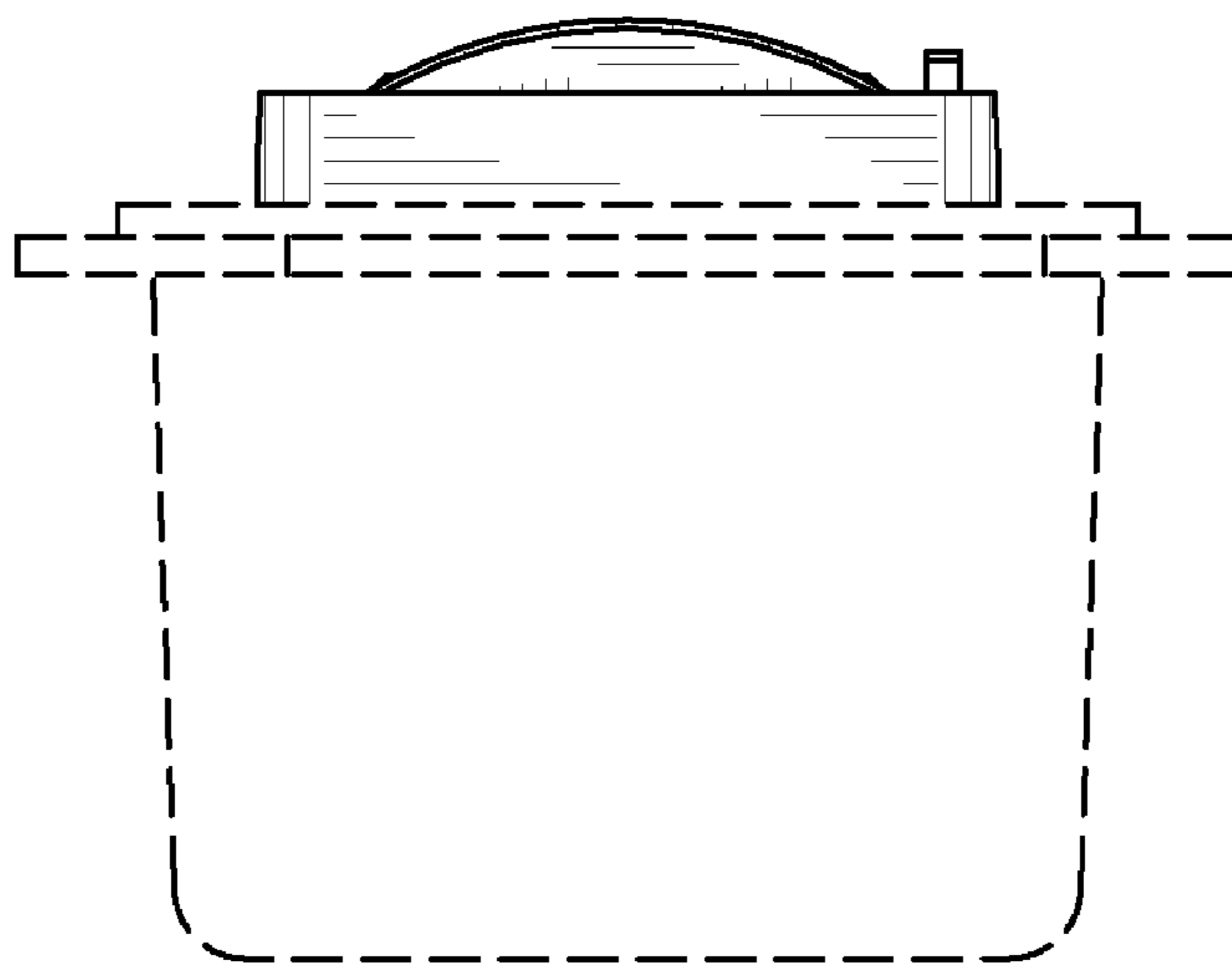

Fig. 16



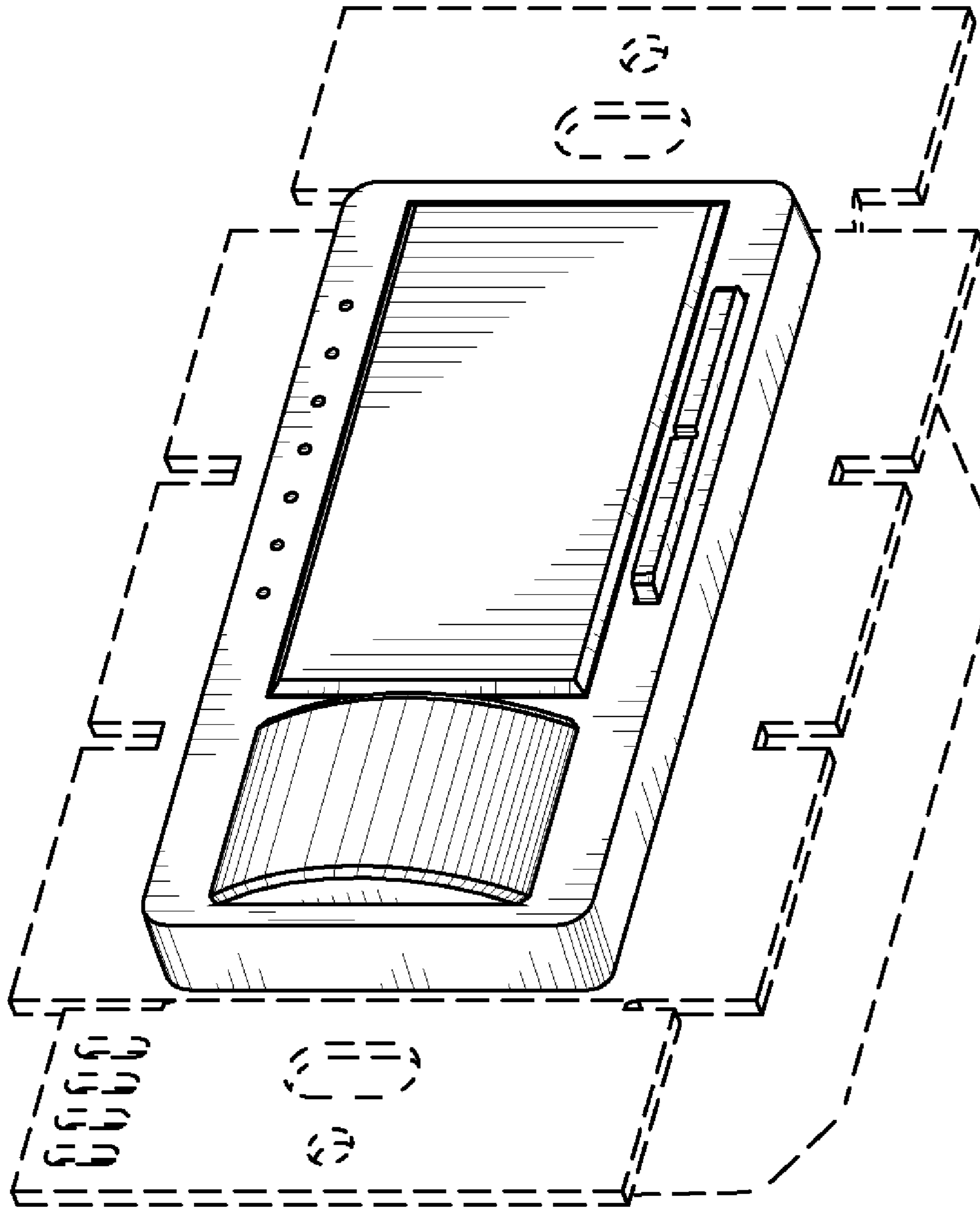

Fig. 17

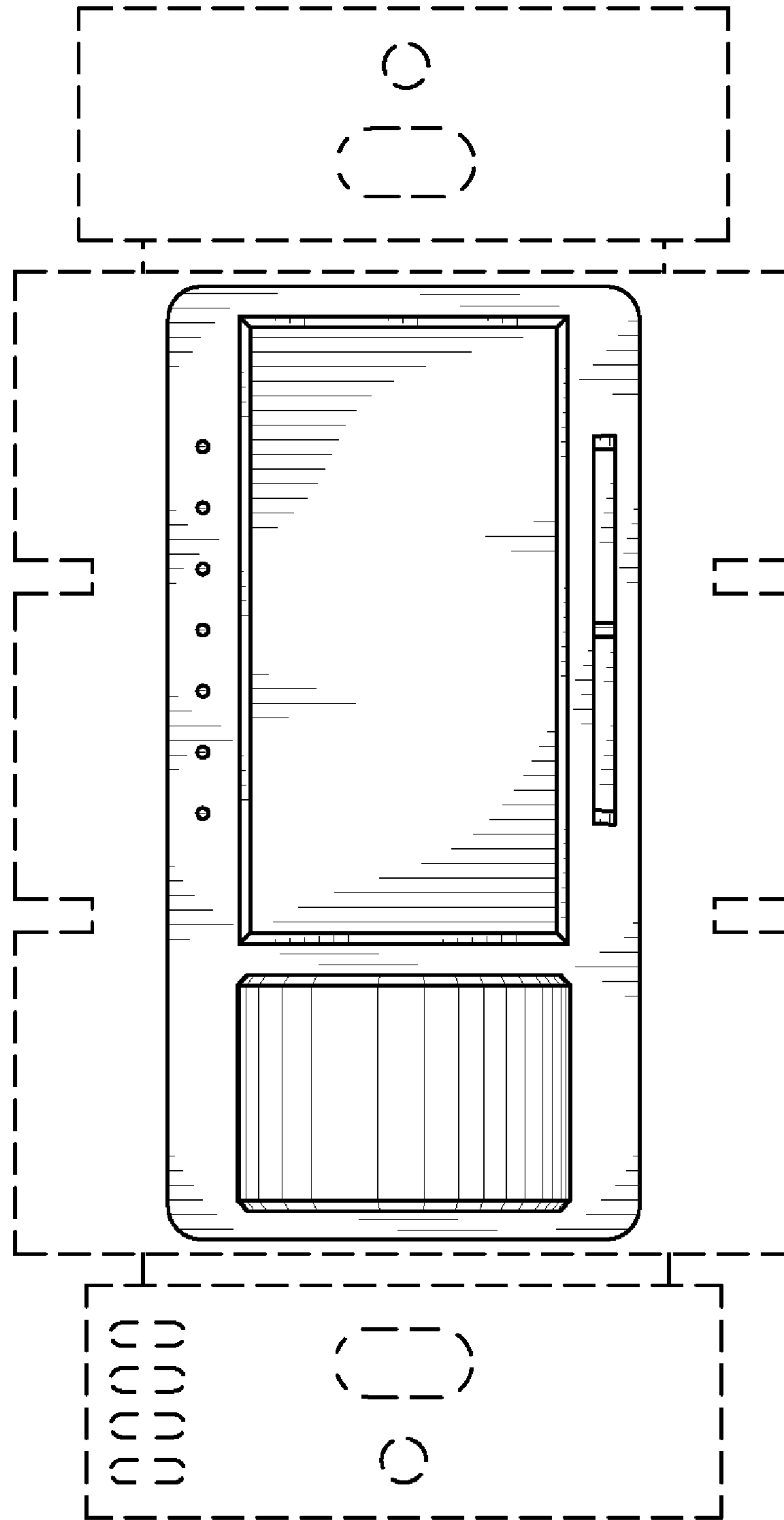

Fig. 18

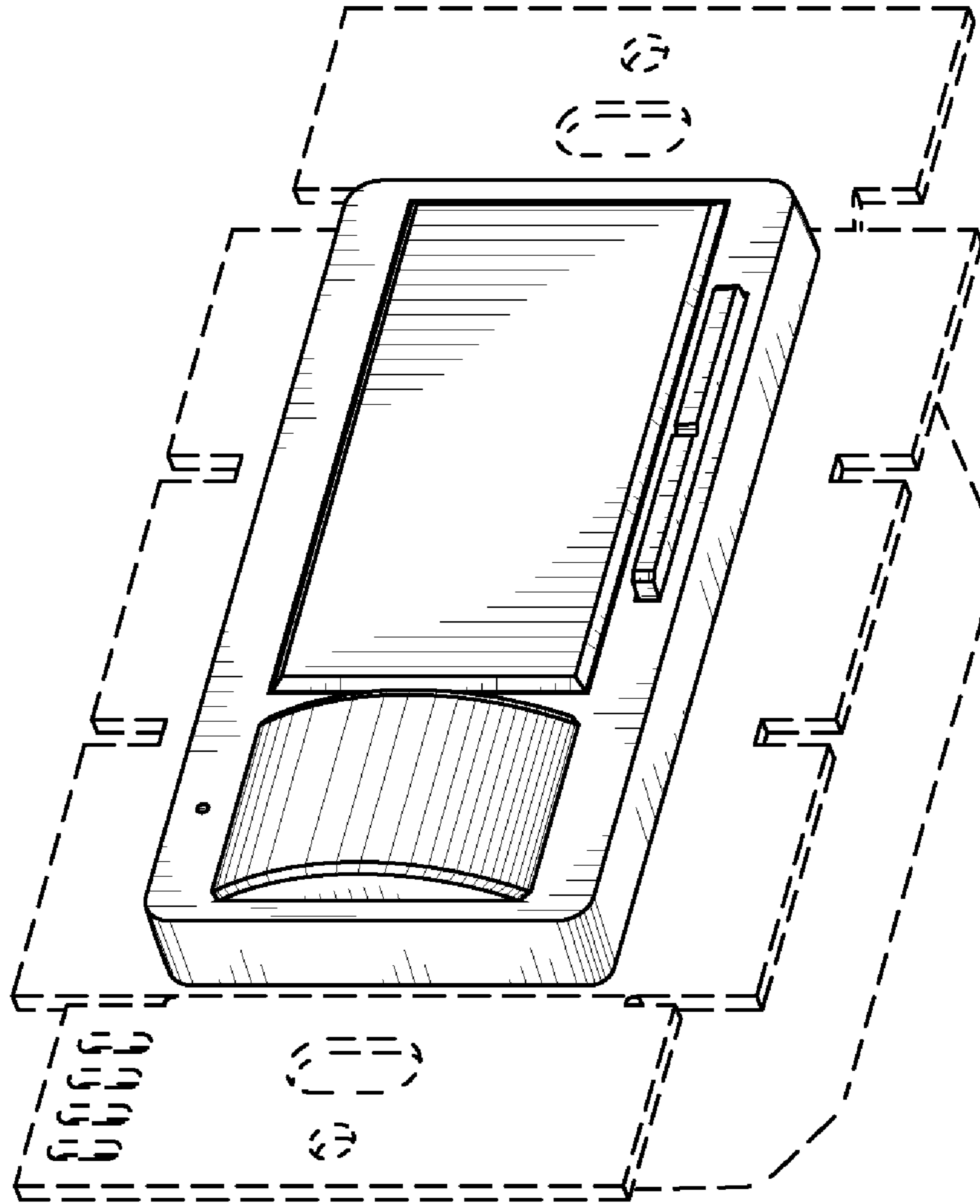

Fig. 19

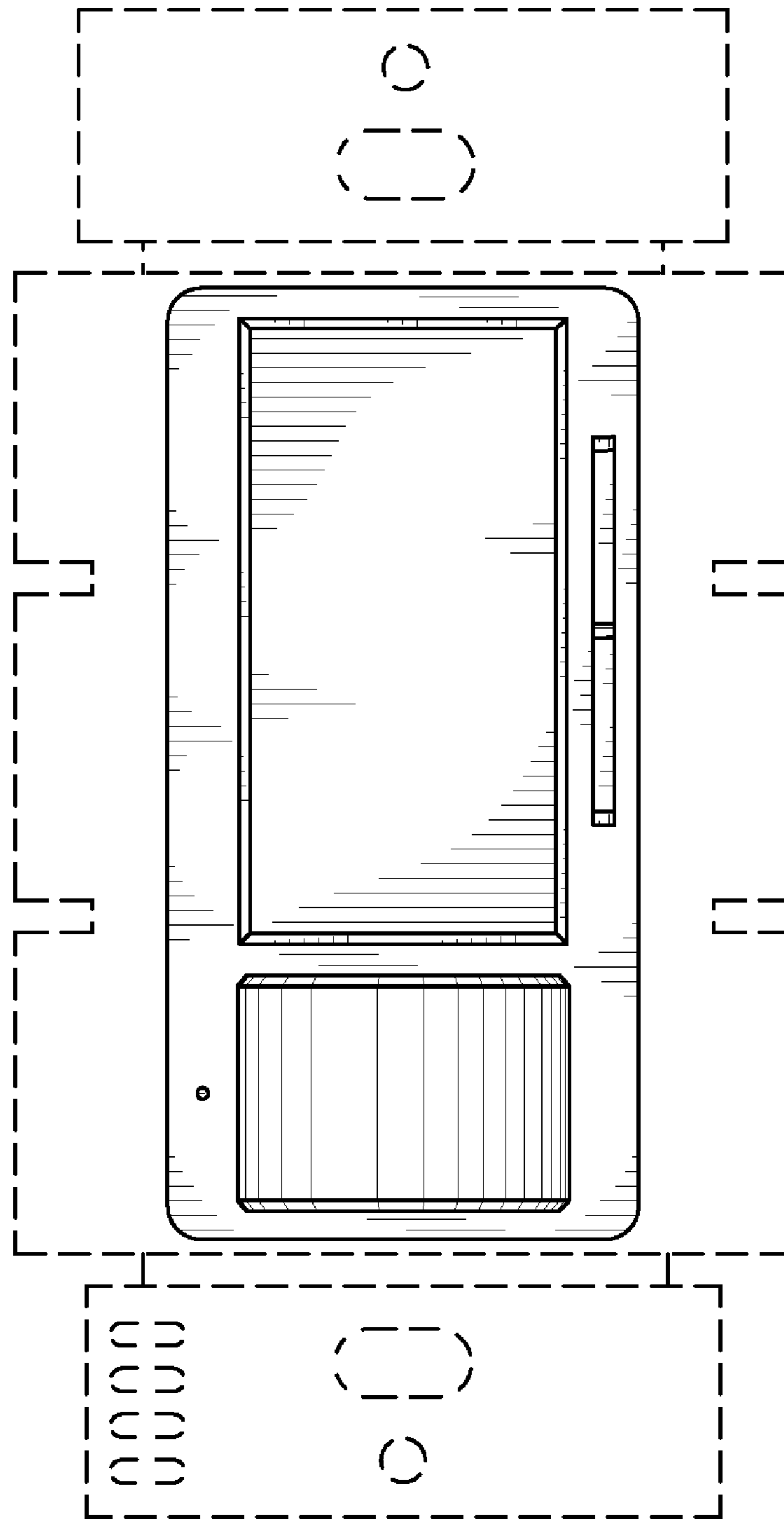

Fig. 20

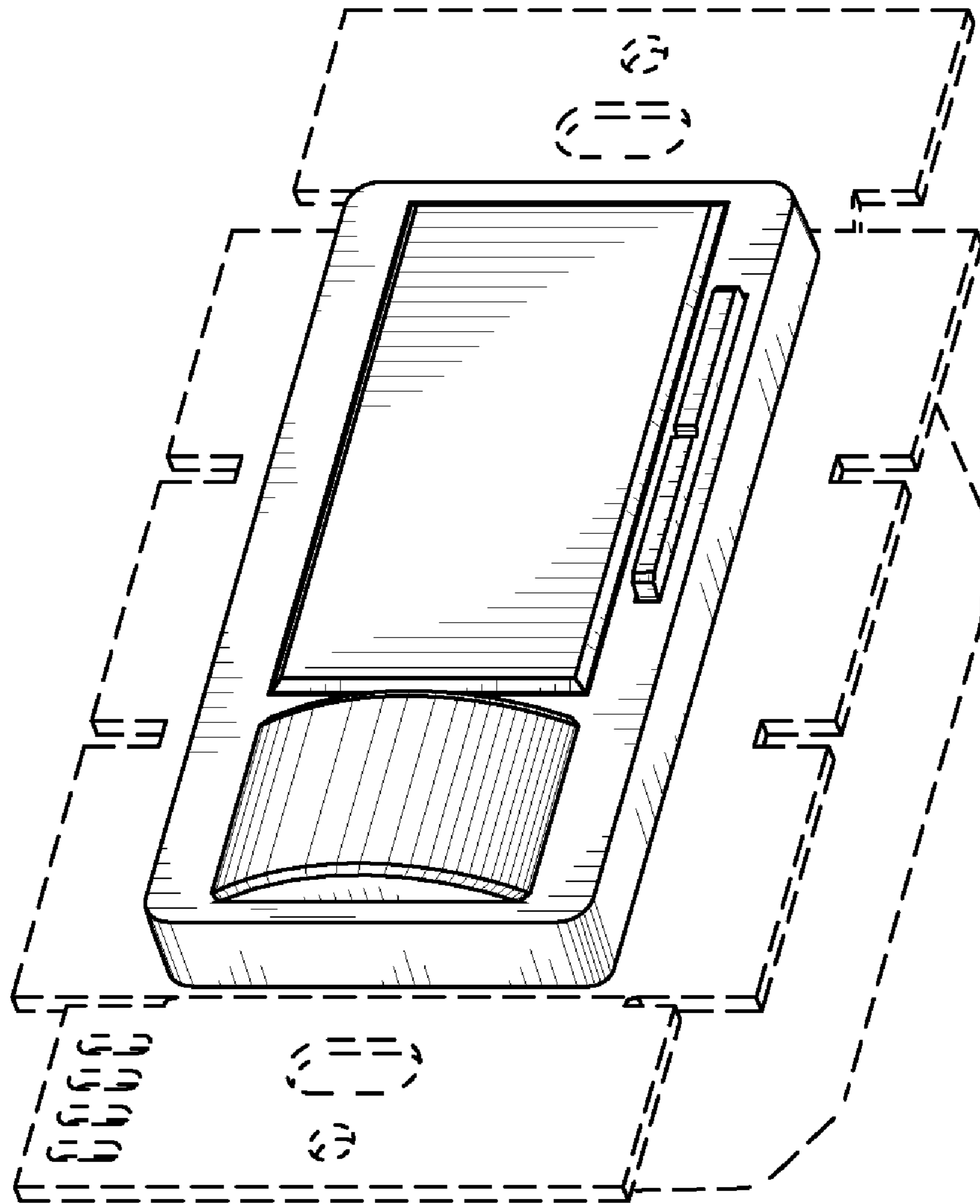

Fig. 21

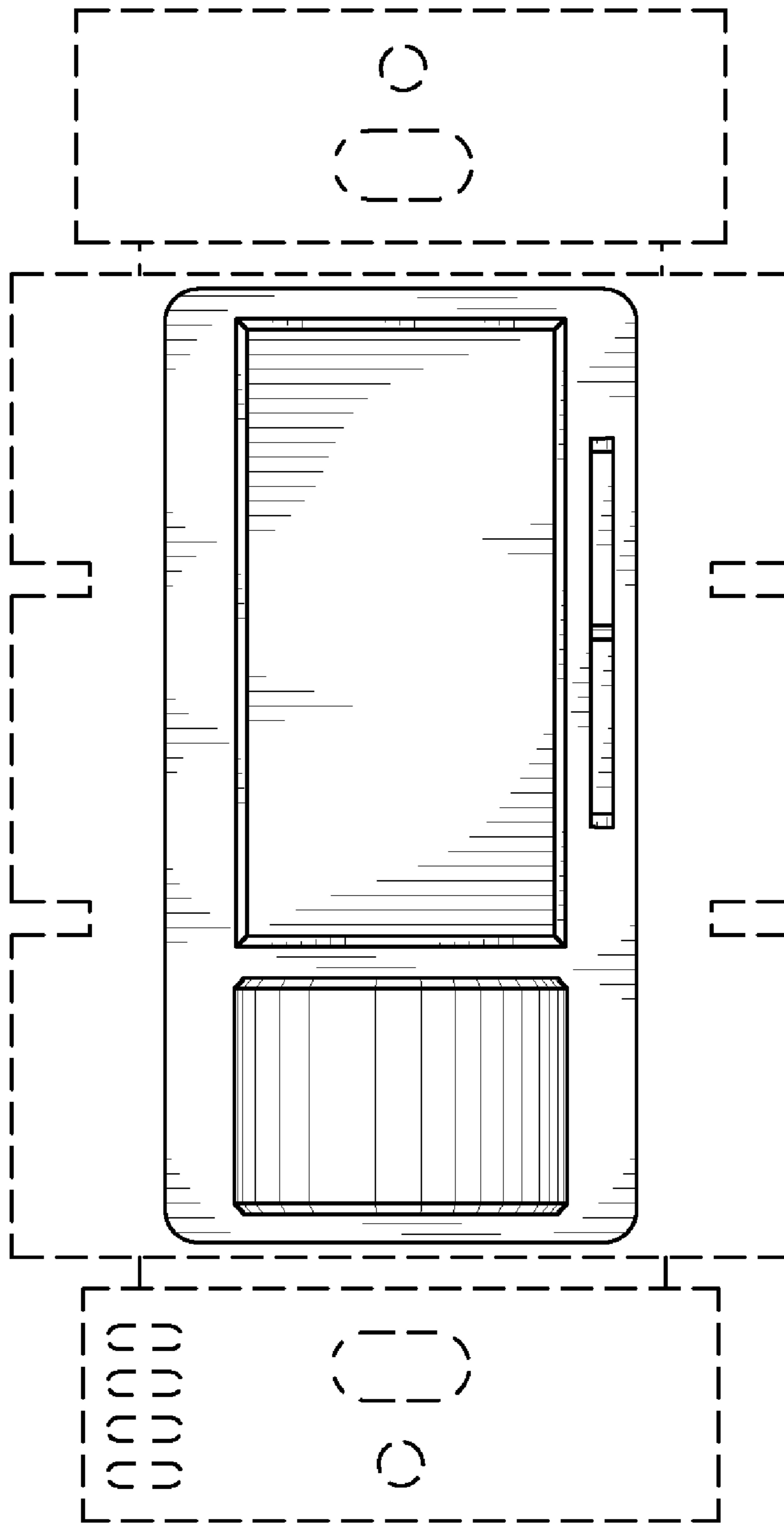

Fig. 22

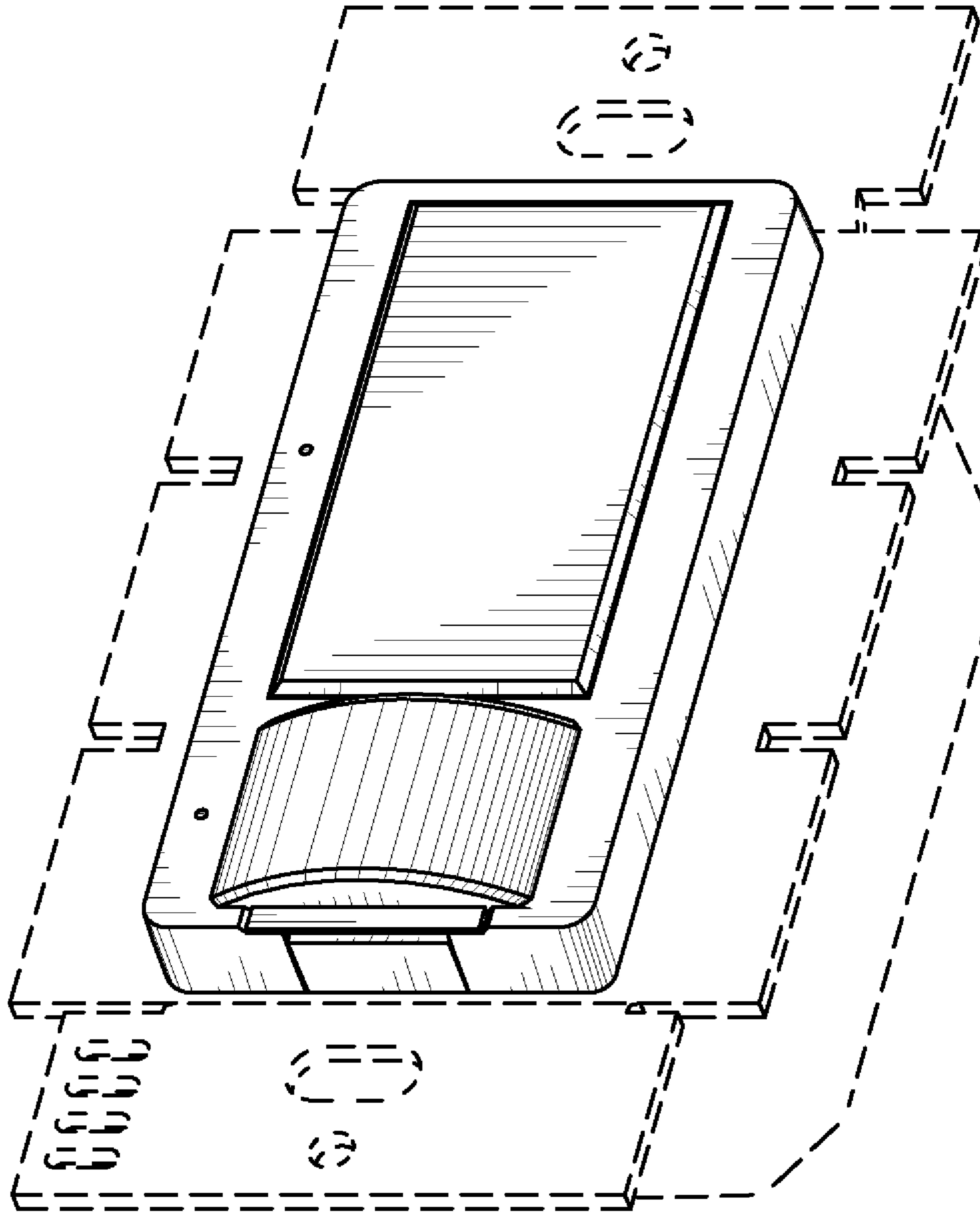

Fig. 23

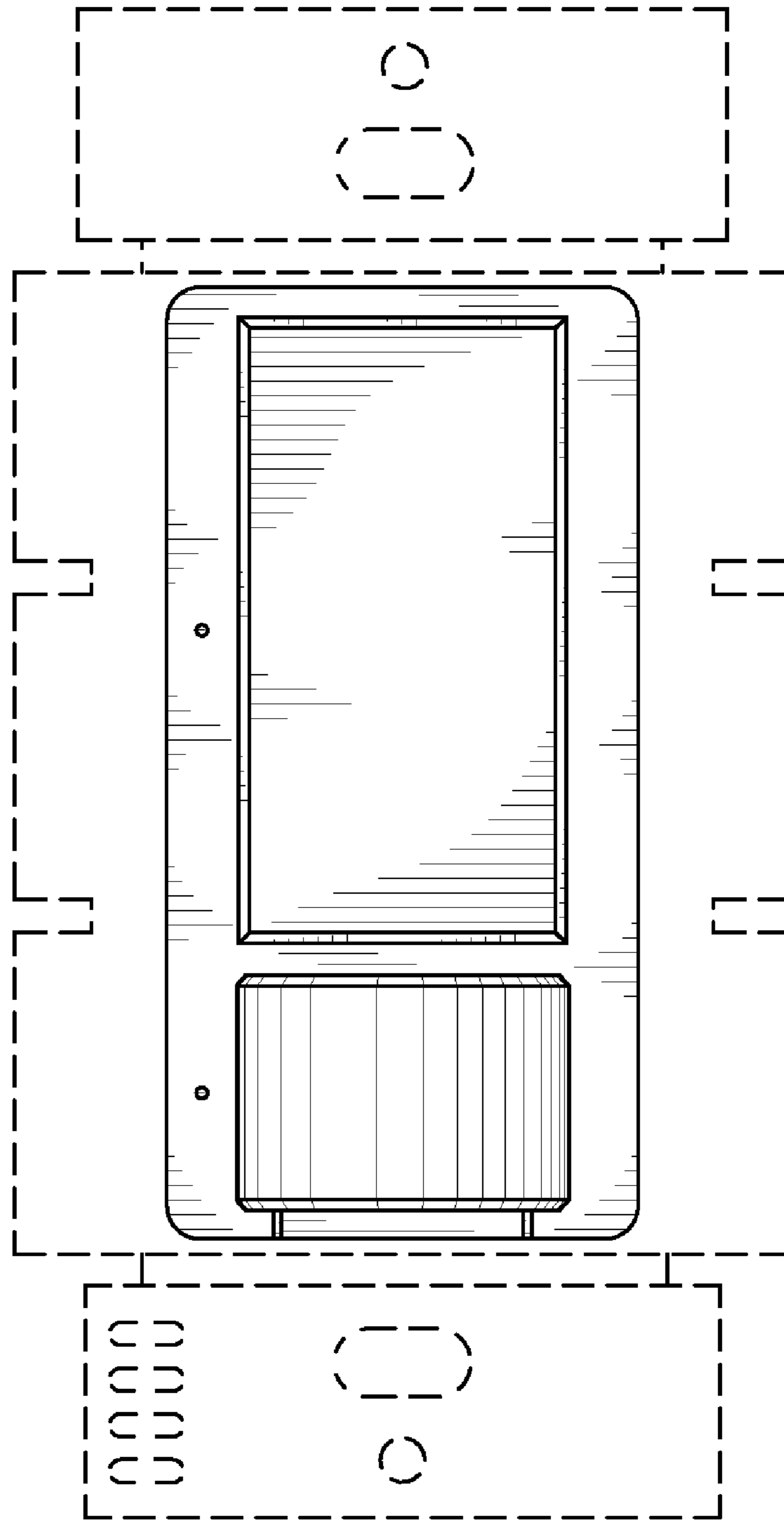

Fig. 24



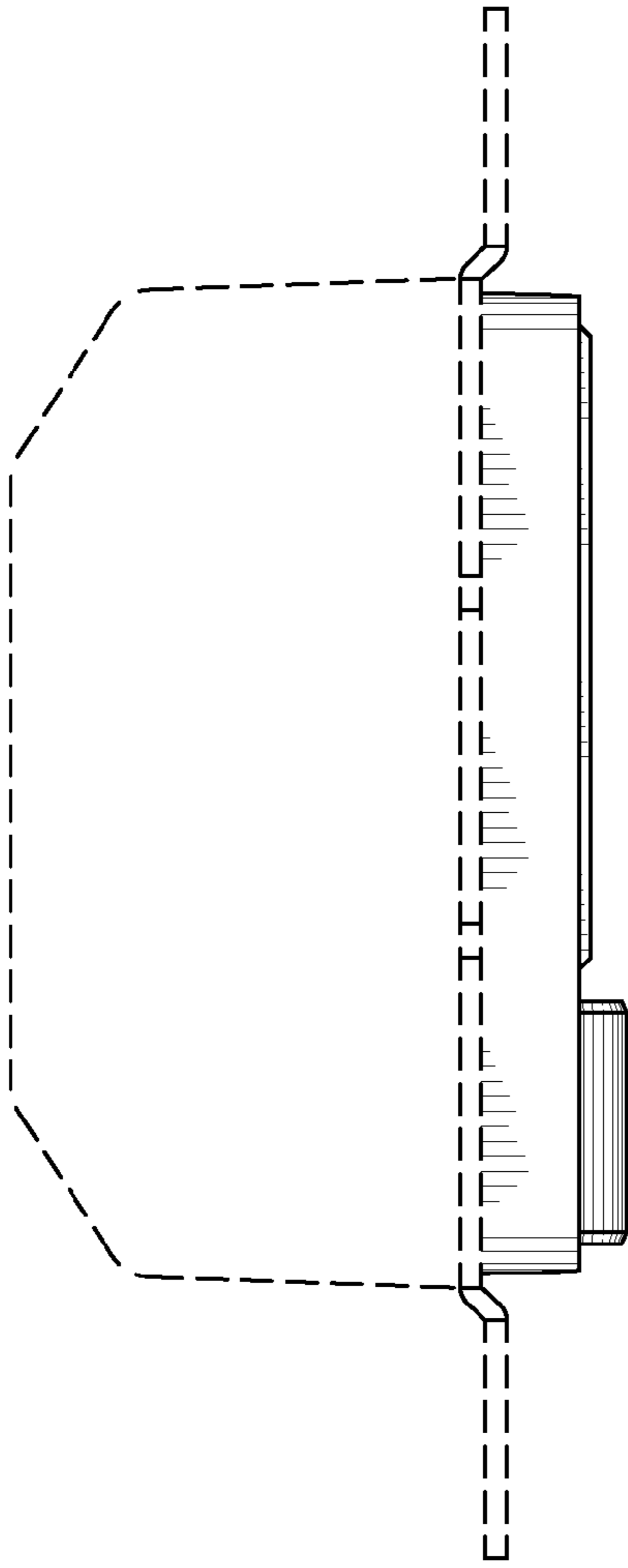

Fig. 25

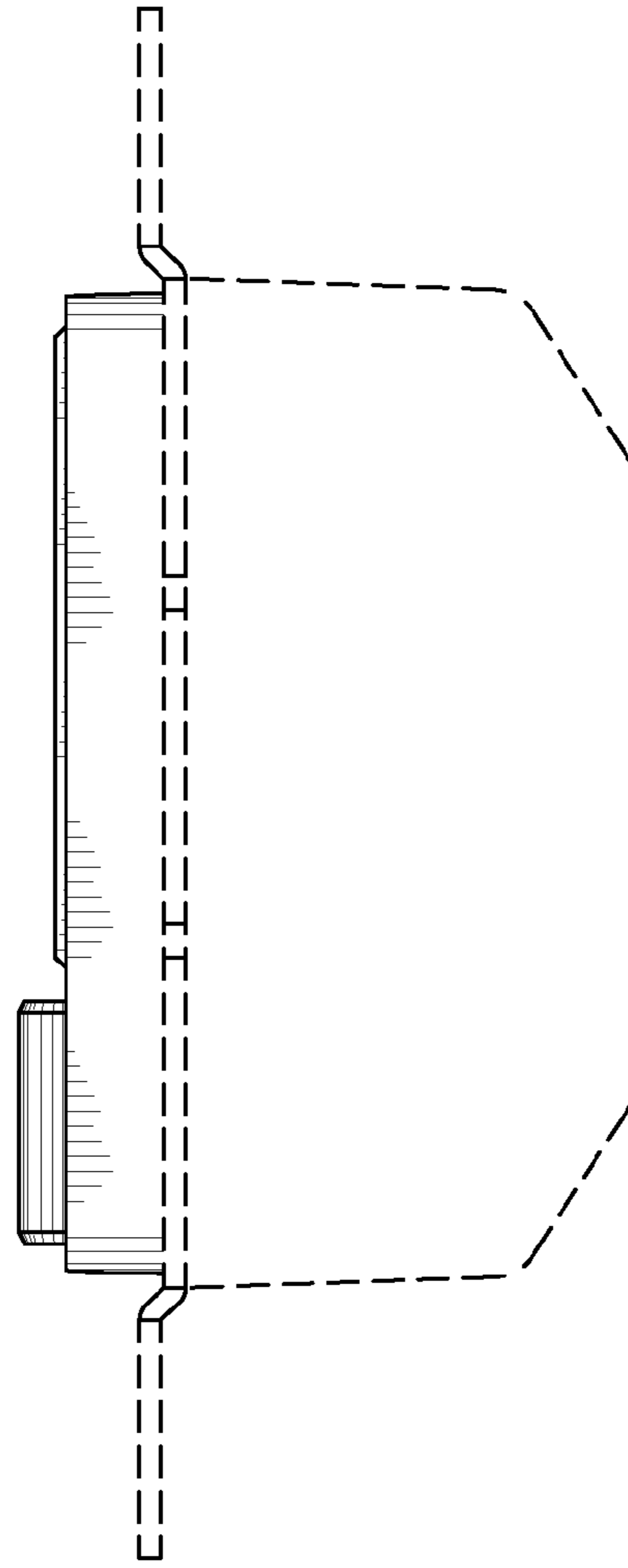

Fig. 26

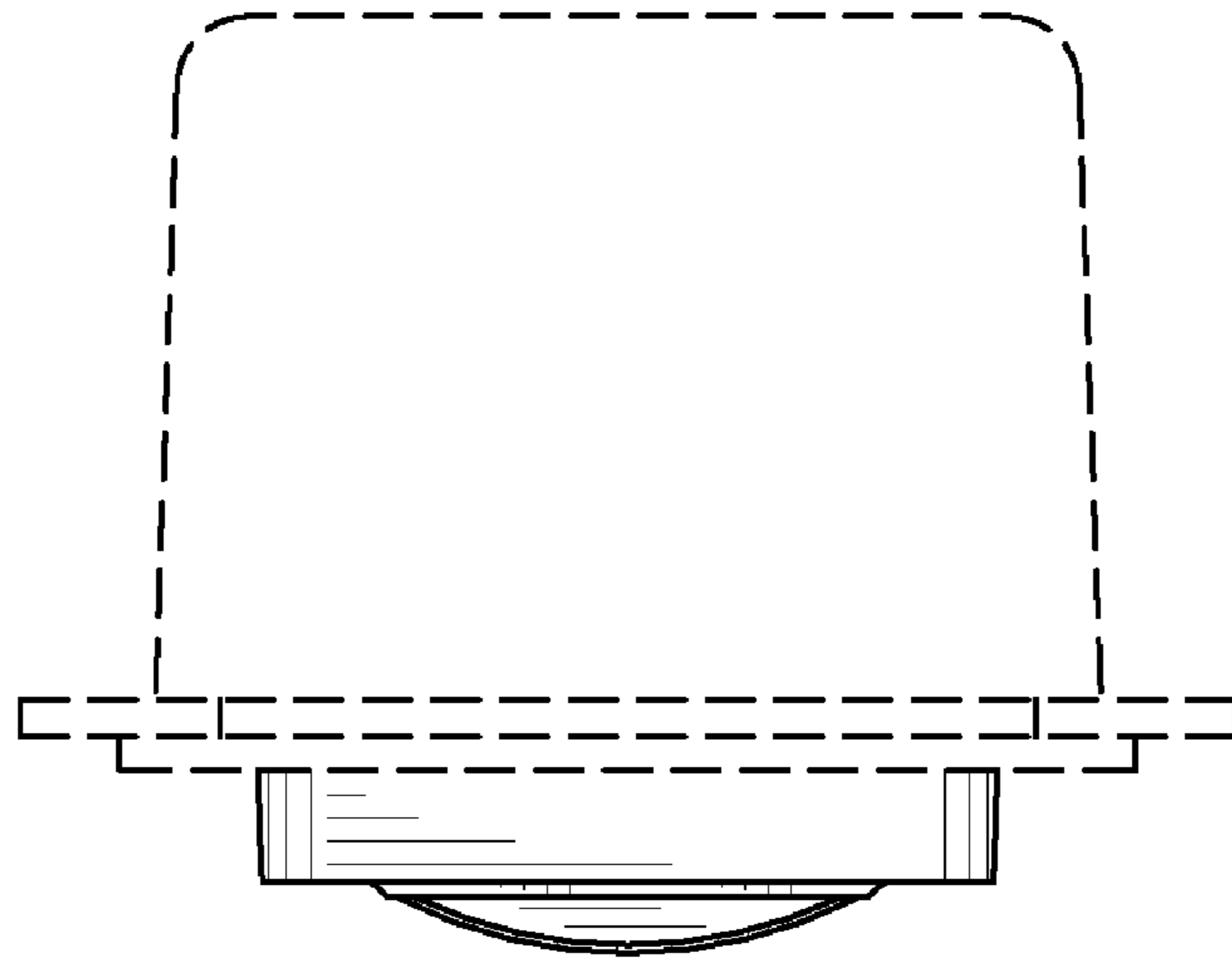

Fig. 27

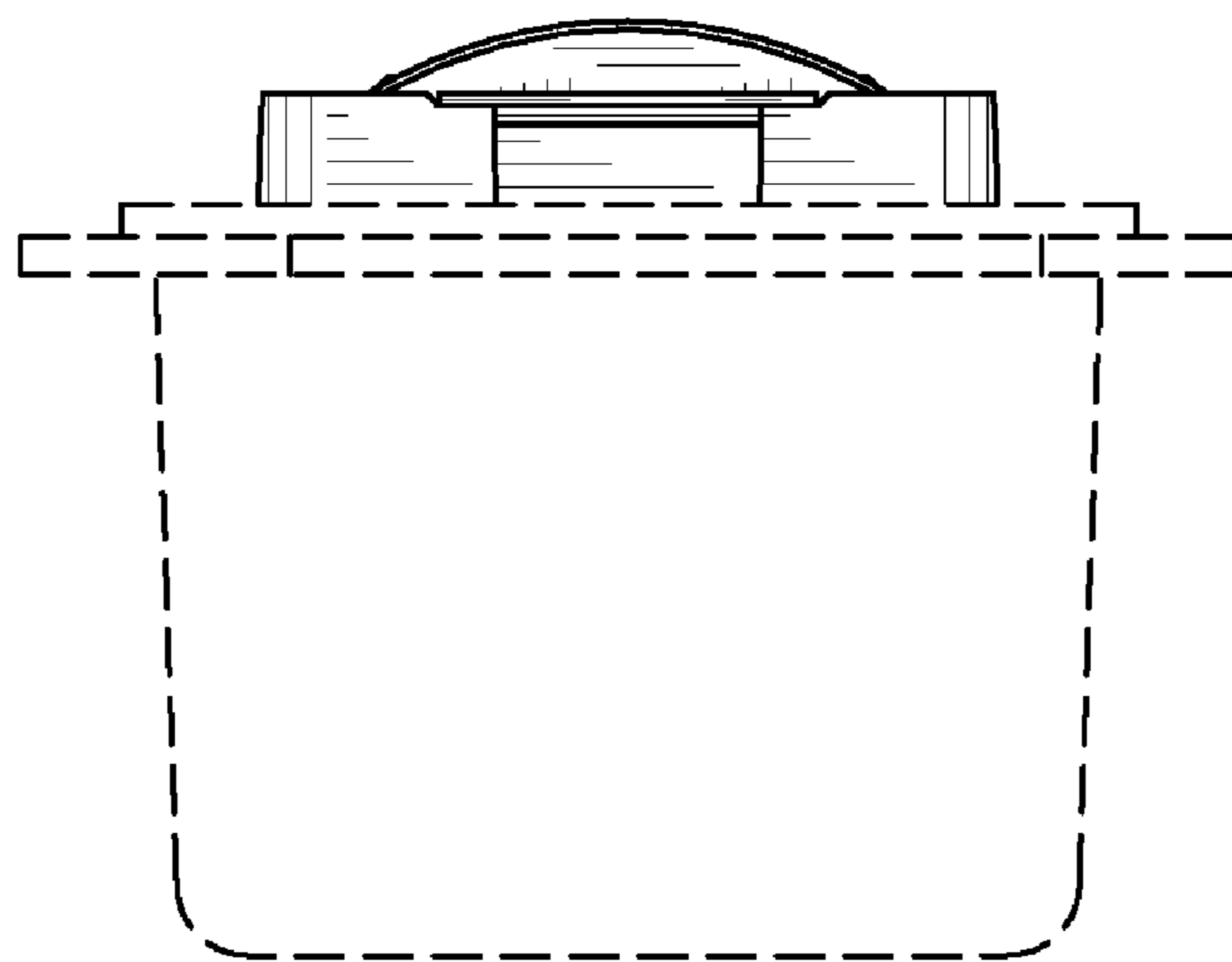

Fig. 28

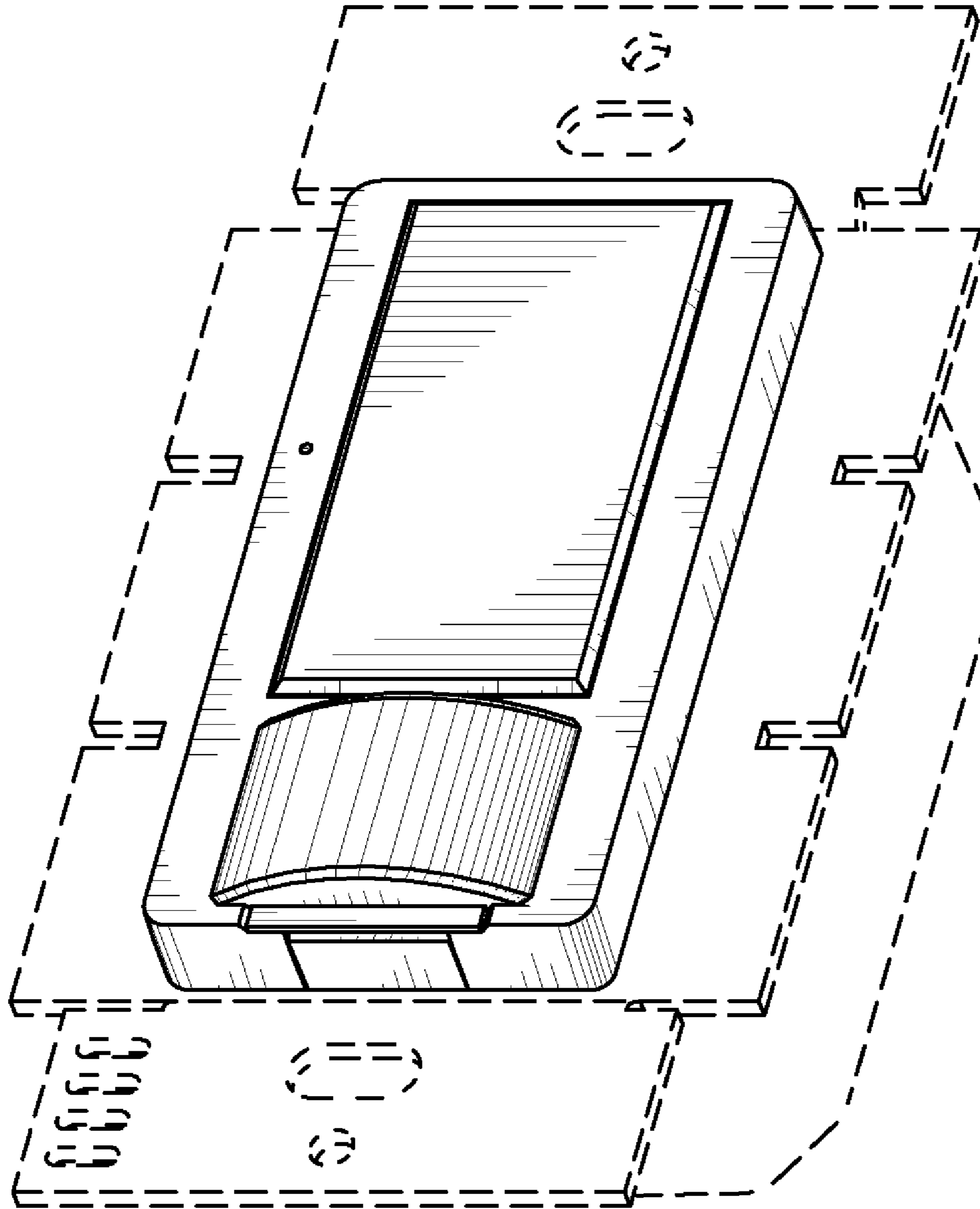

Fig. 29

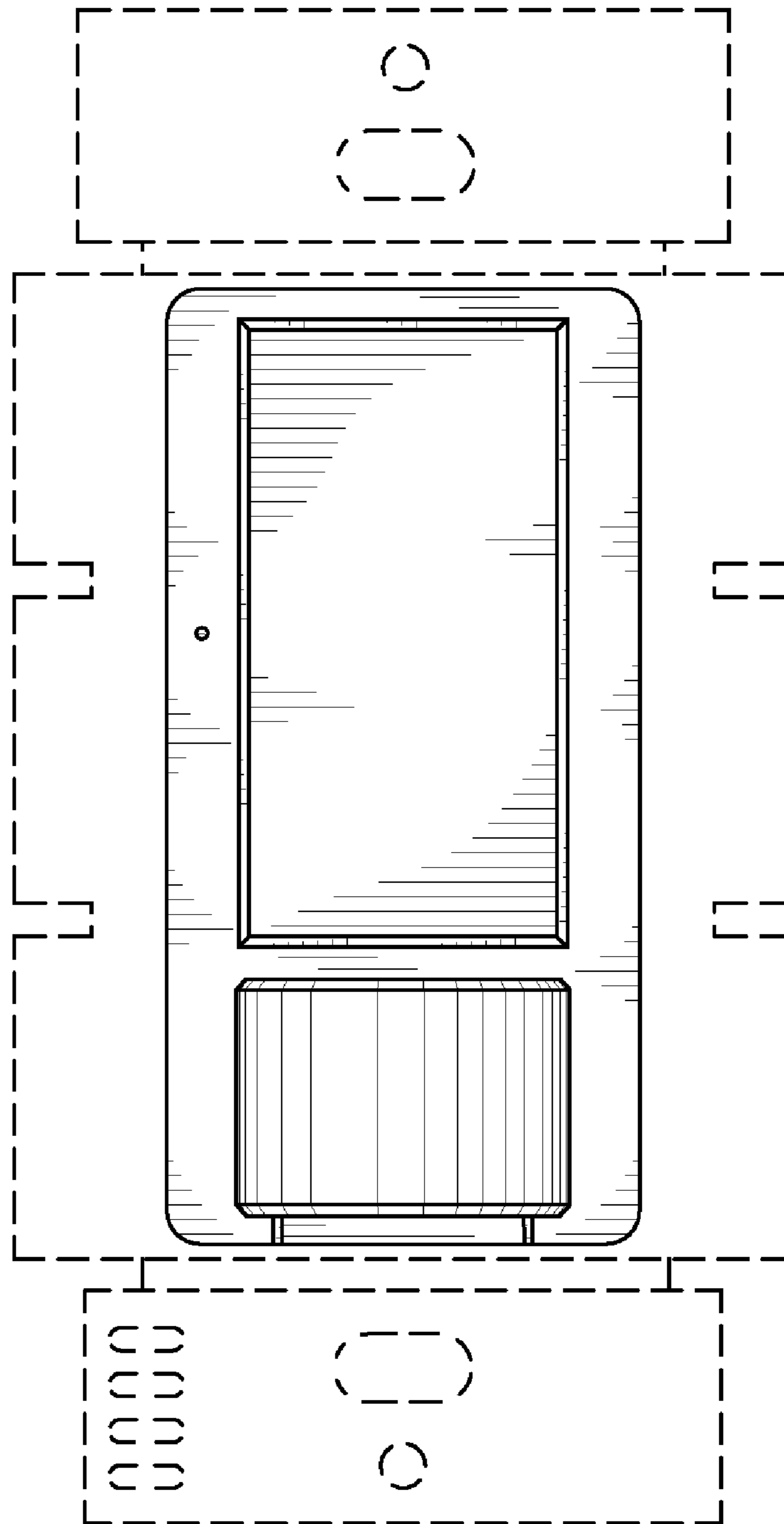

Fig. 30

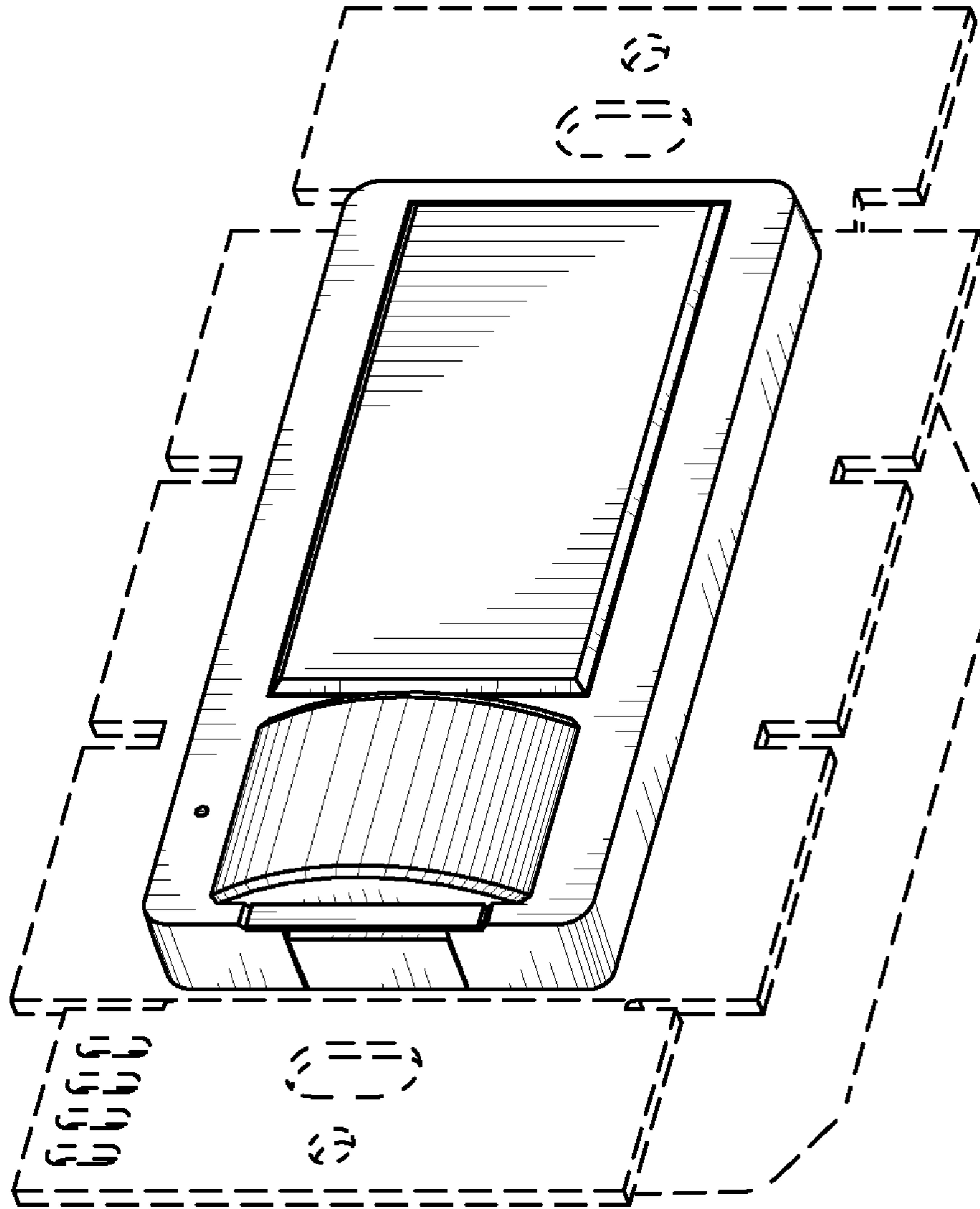

Fig. 31

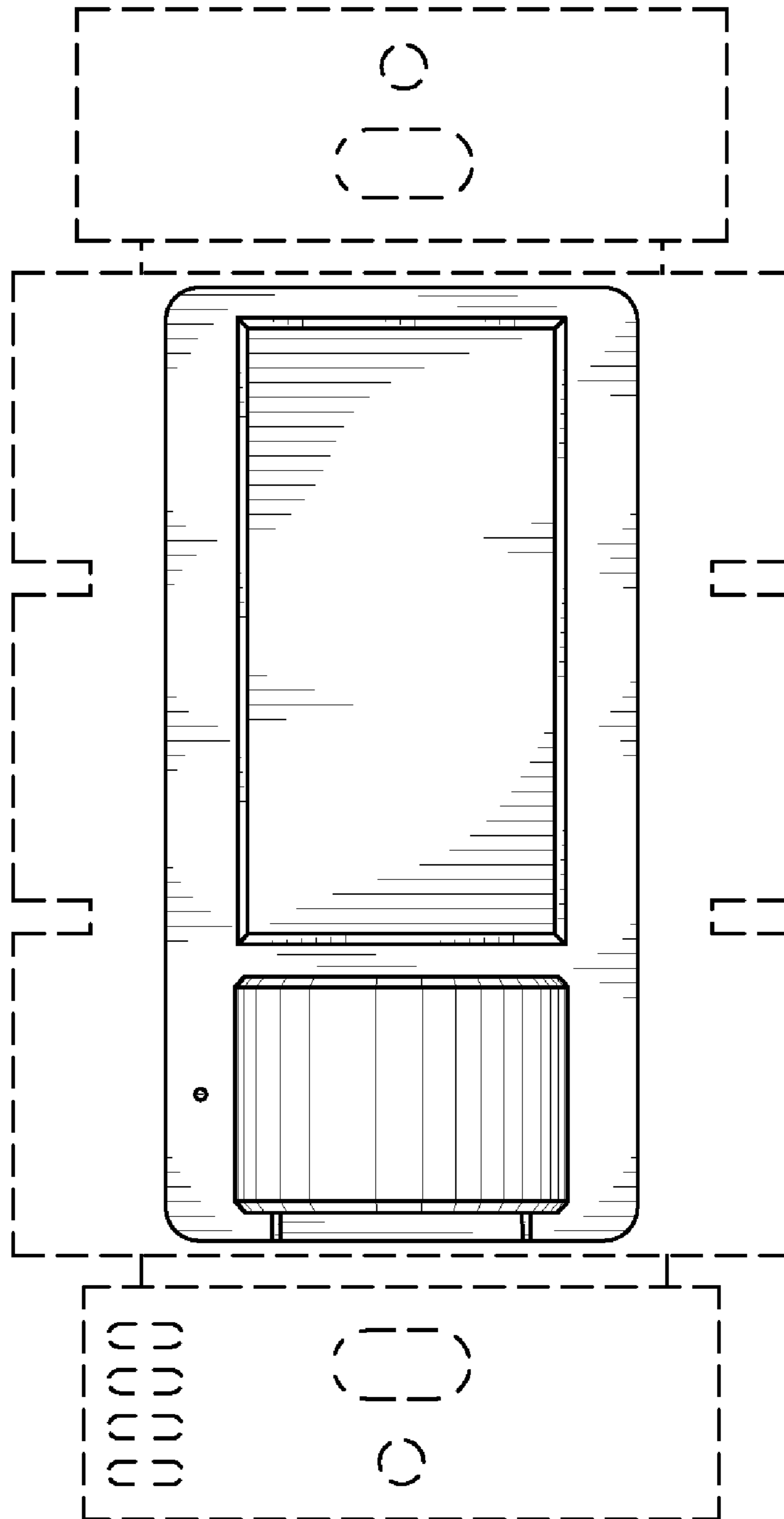

Fig. 32

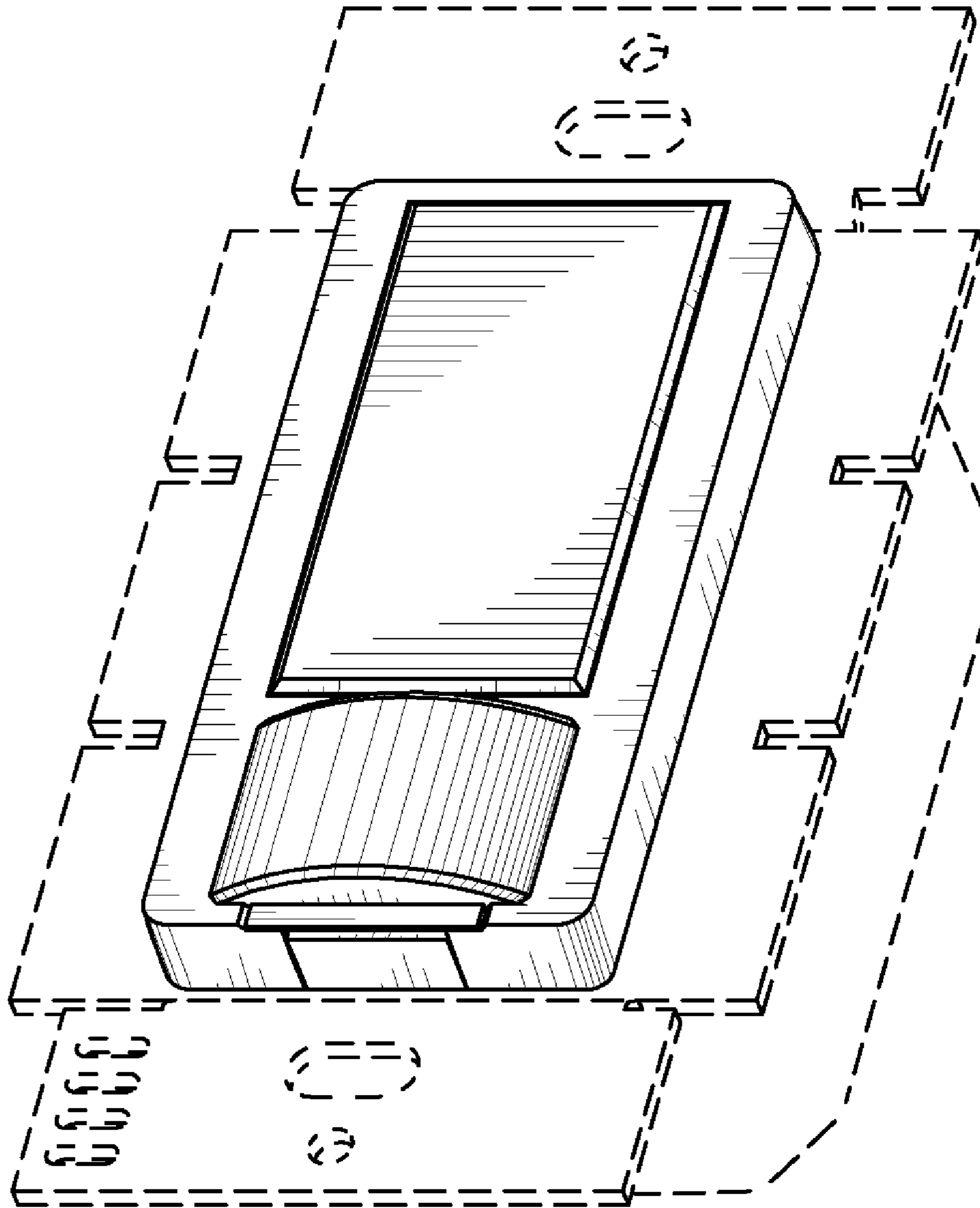

Fig. 33

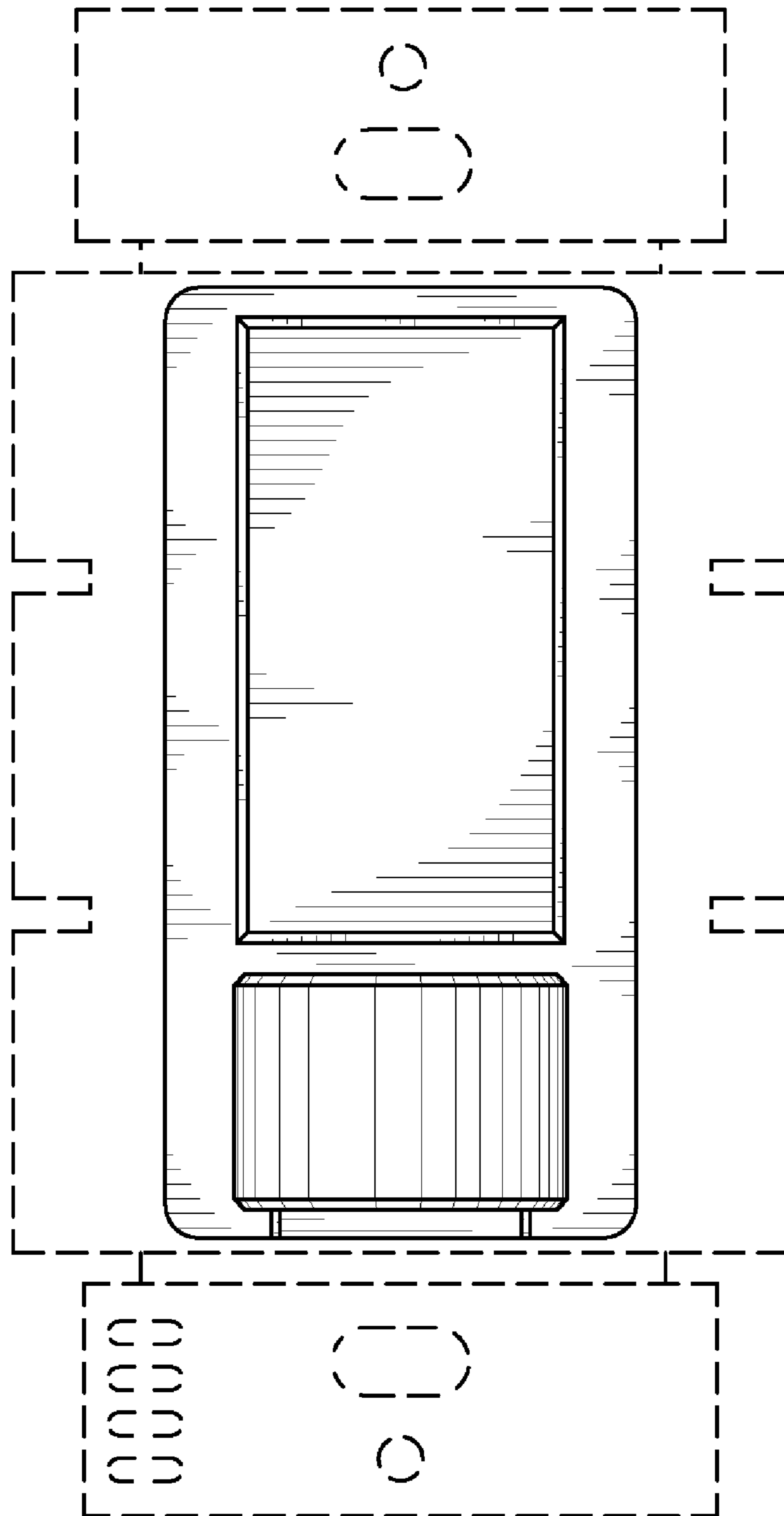

Fig. 34



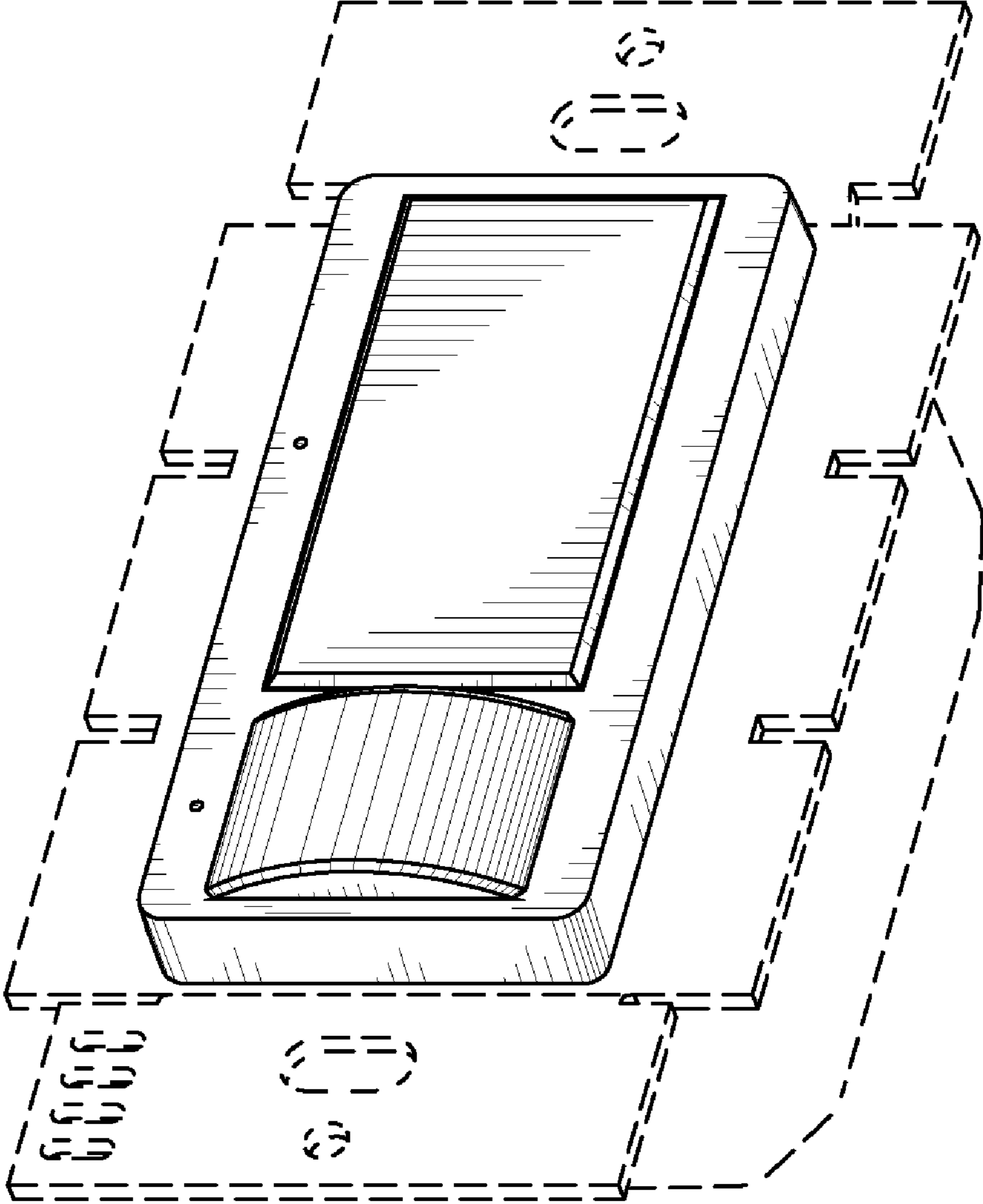

Fig. 35

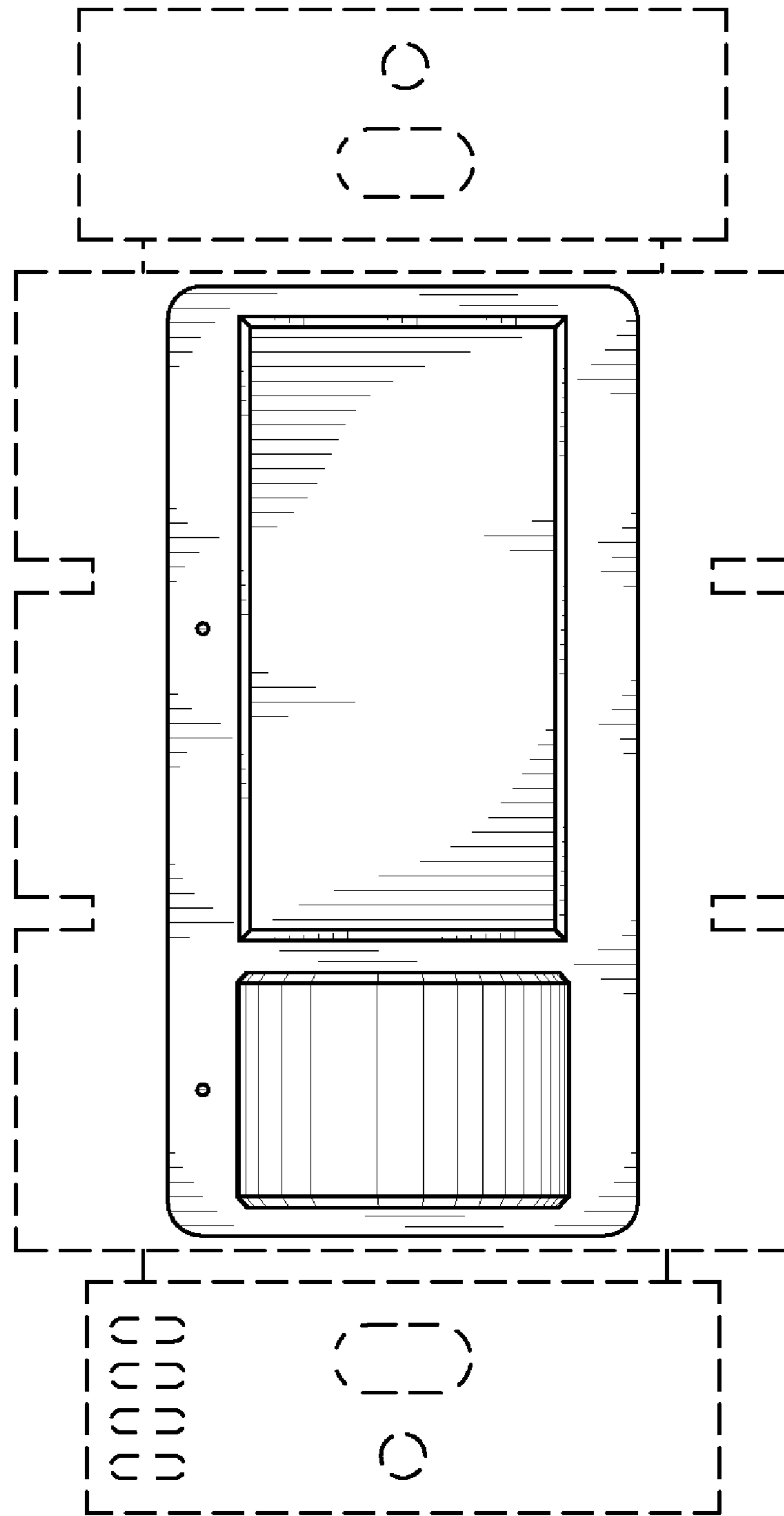

Fig. 36

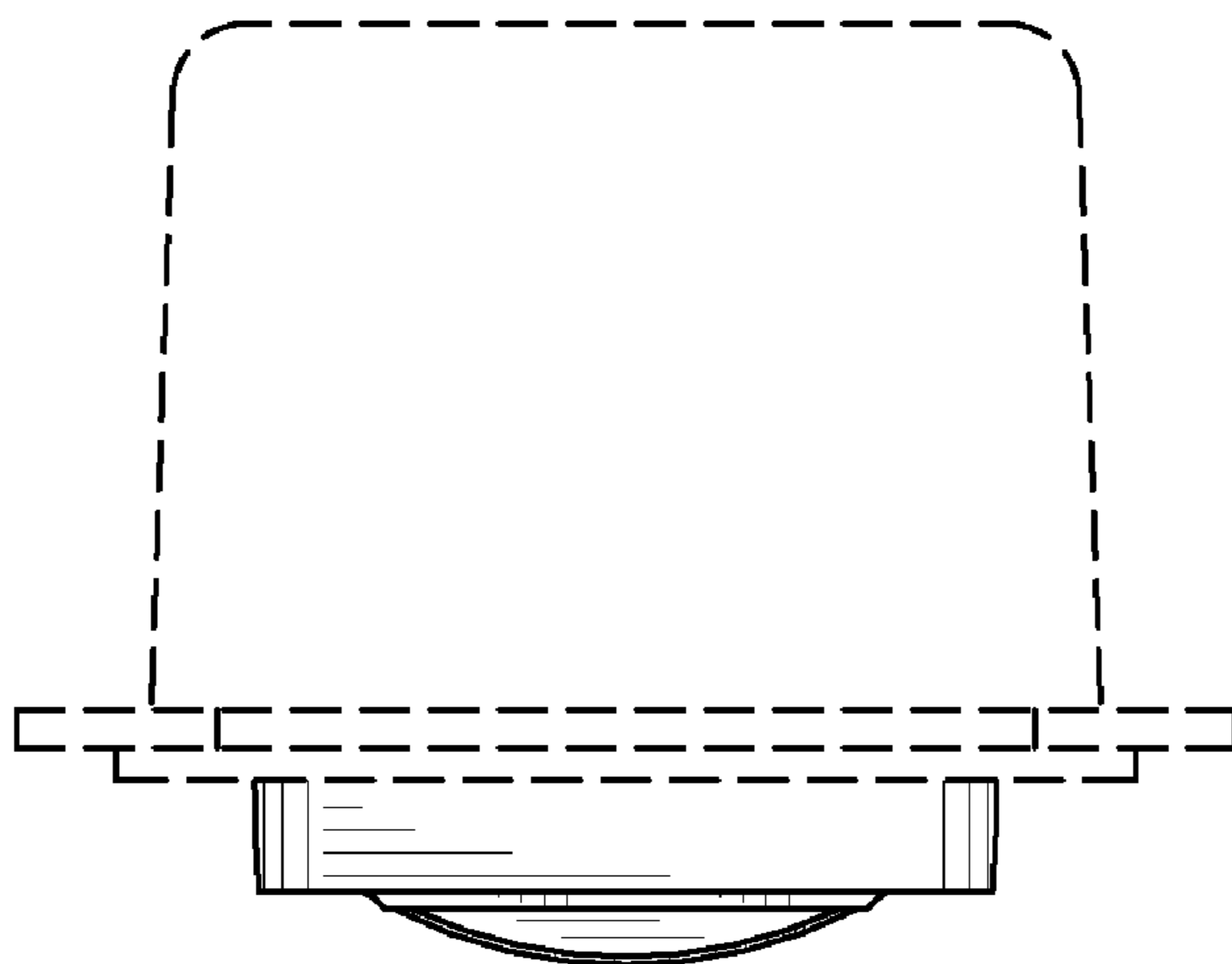

Fig. 37

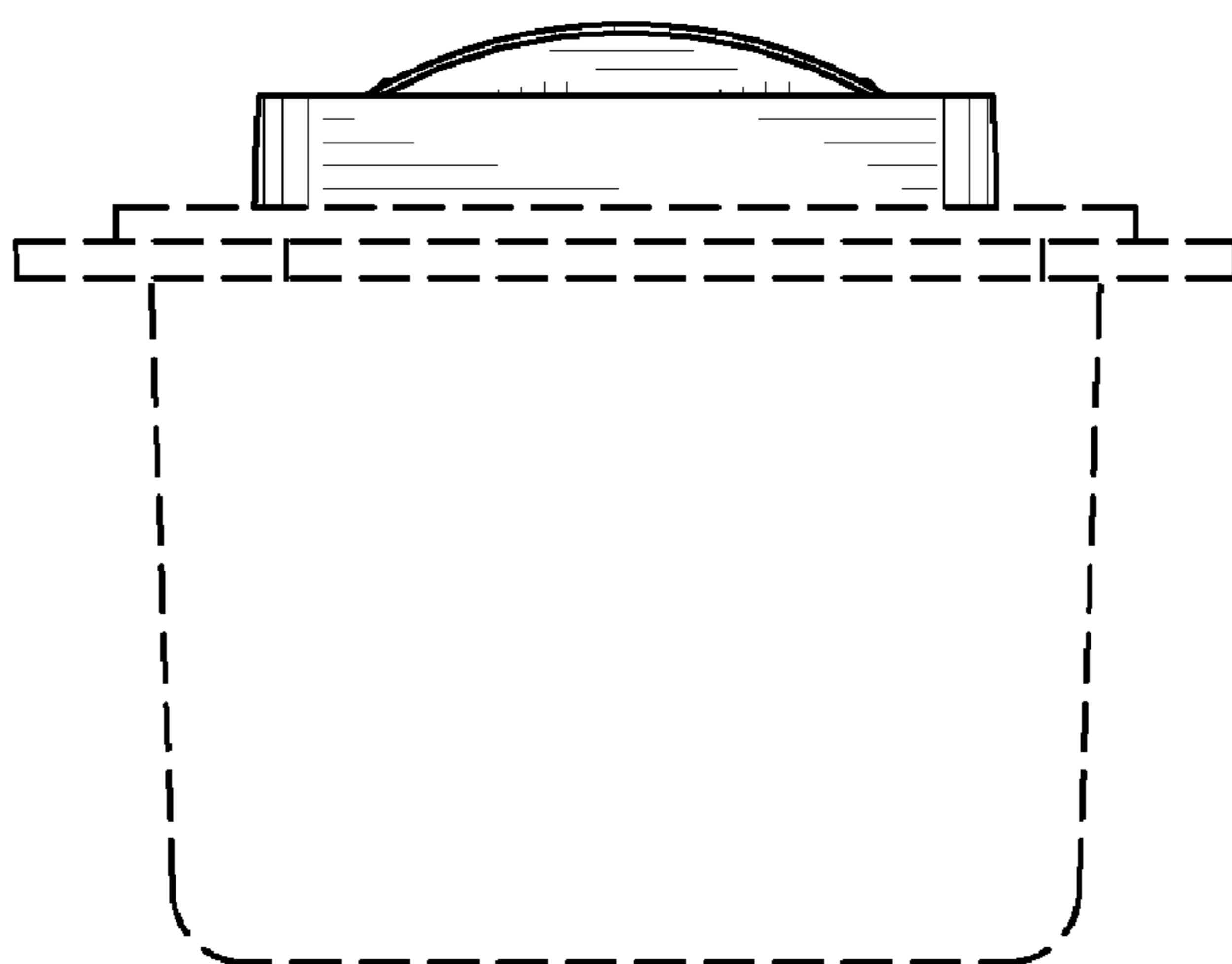

Fig. 38

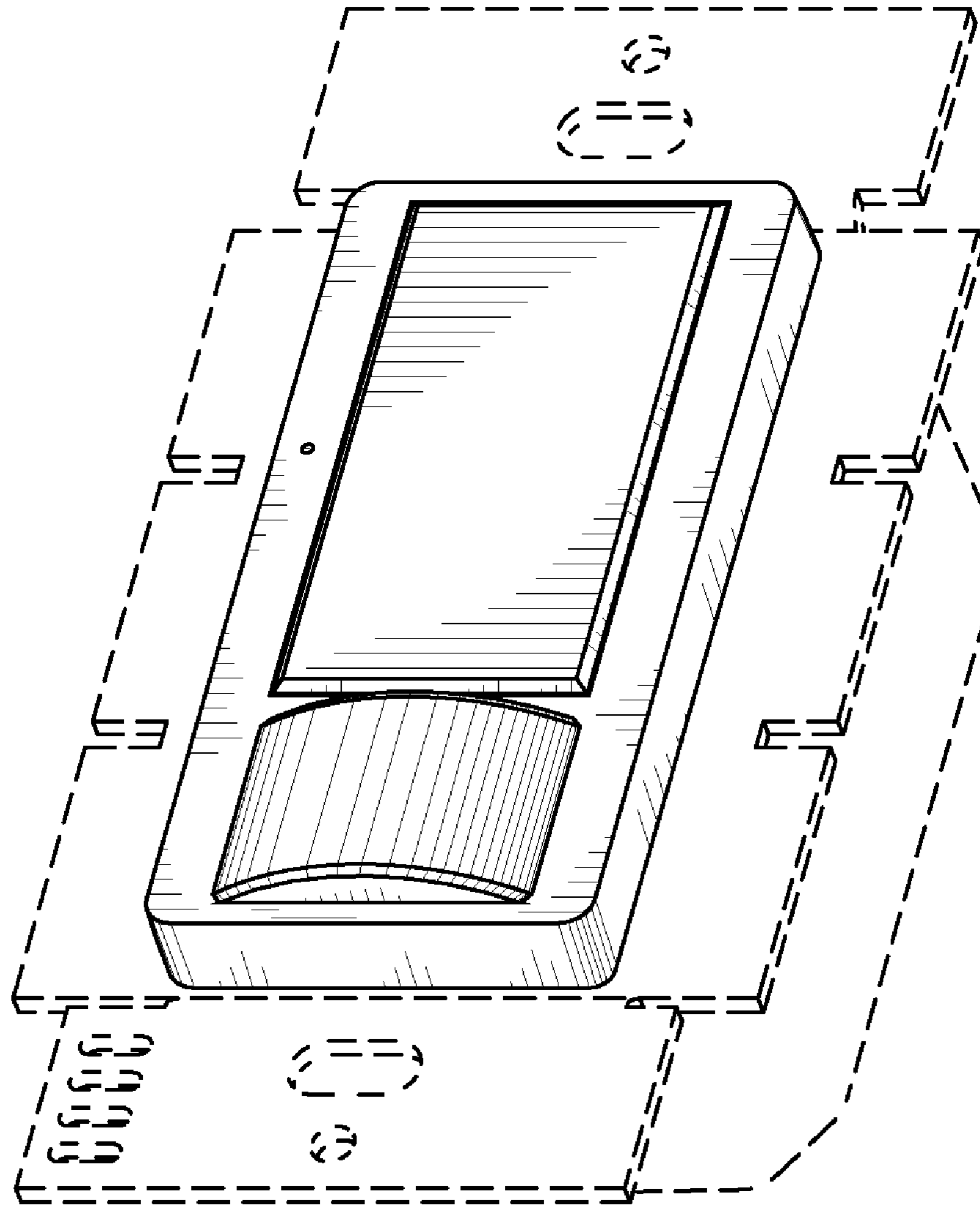

Fig. 39

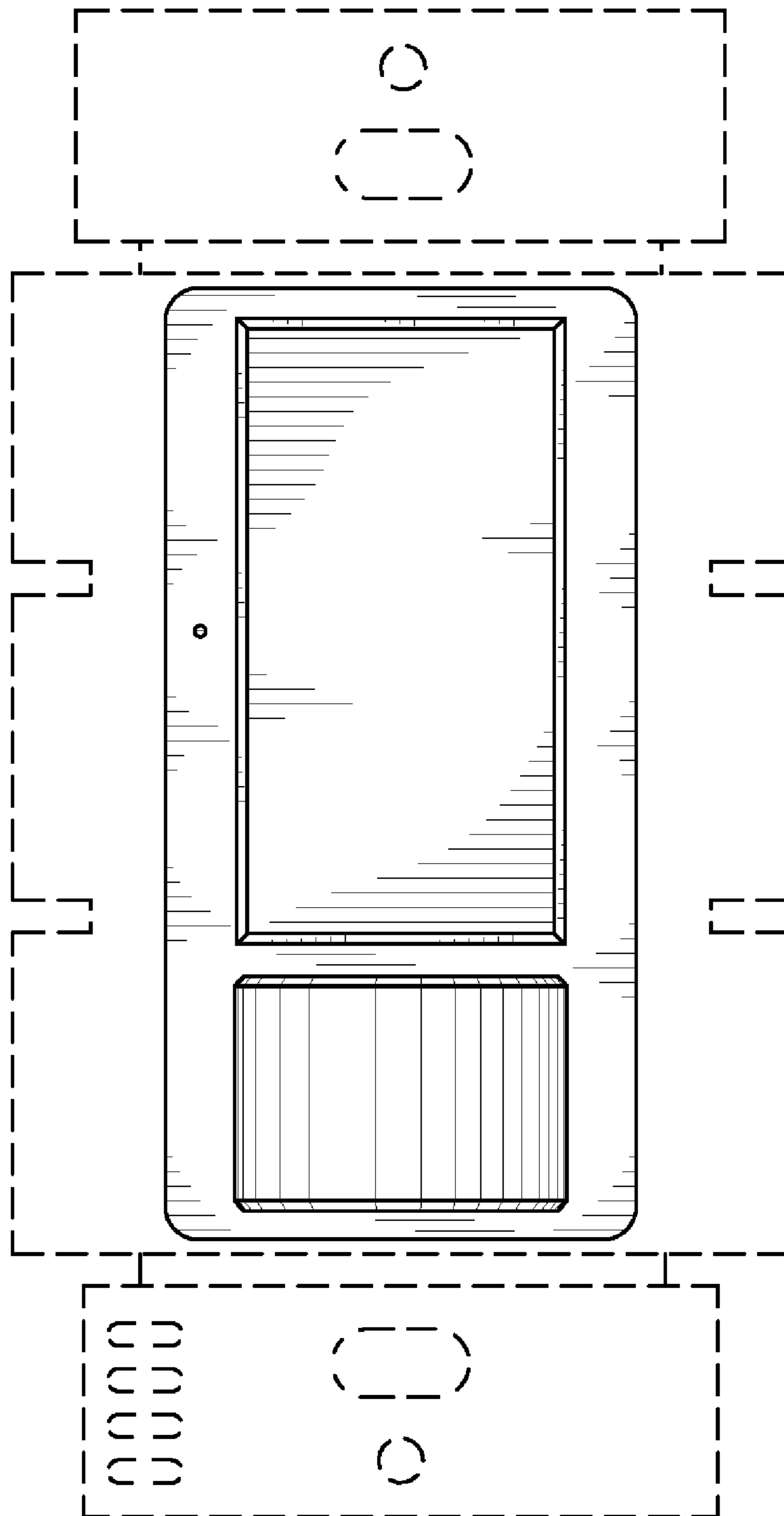

Fig. 40

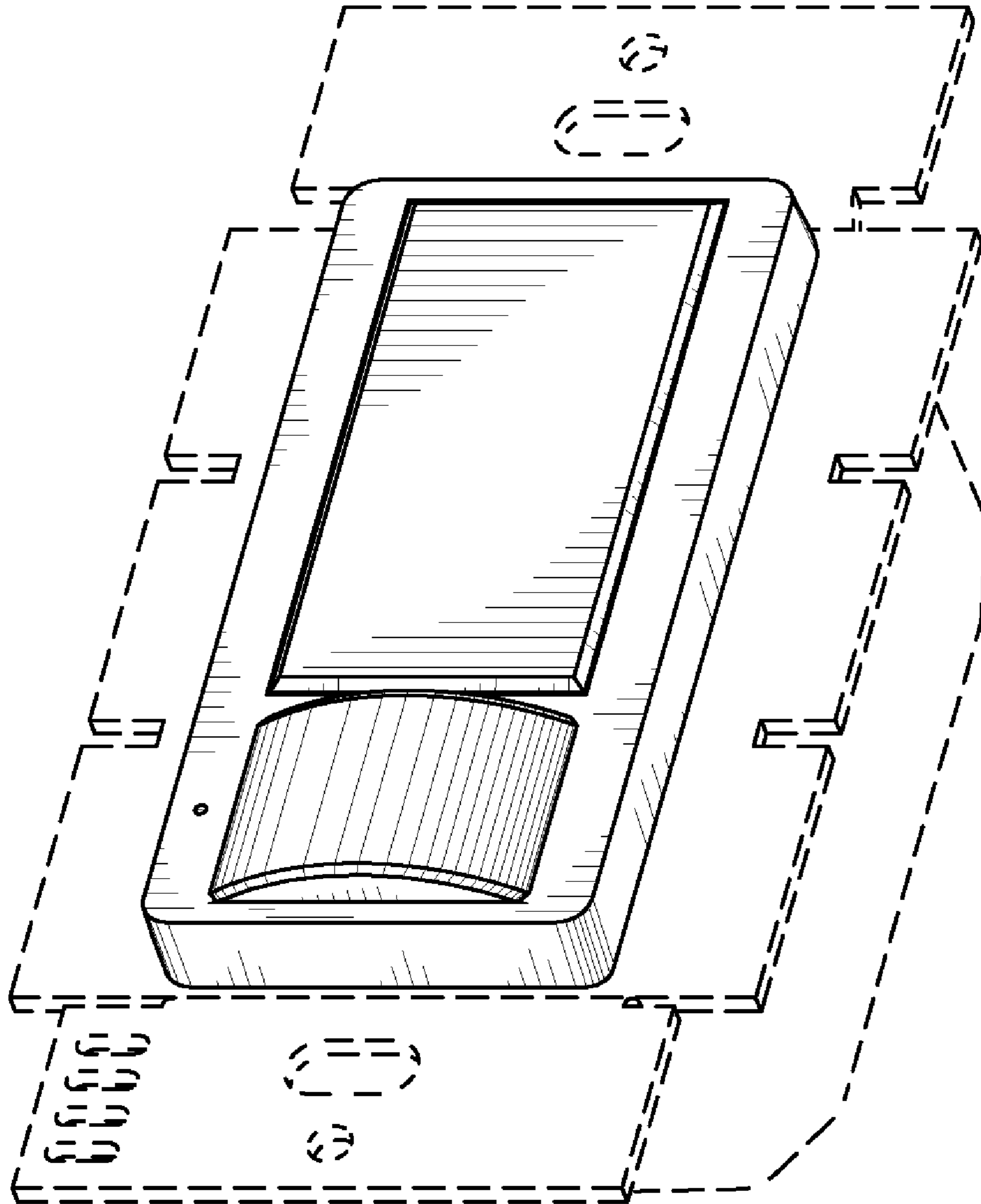

Fig. 41

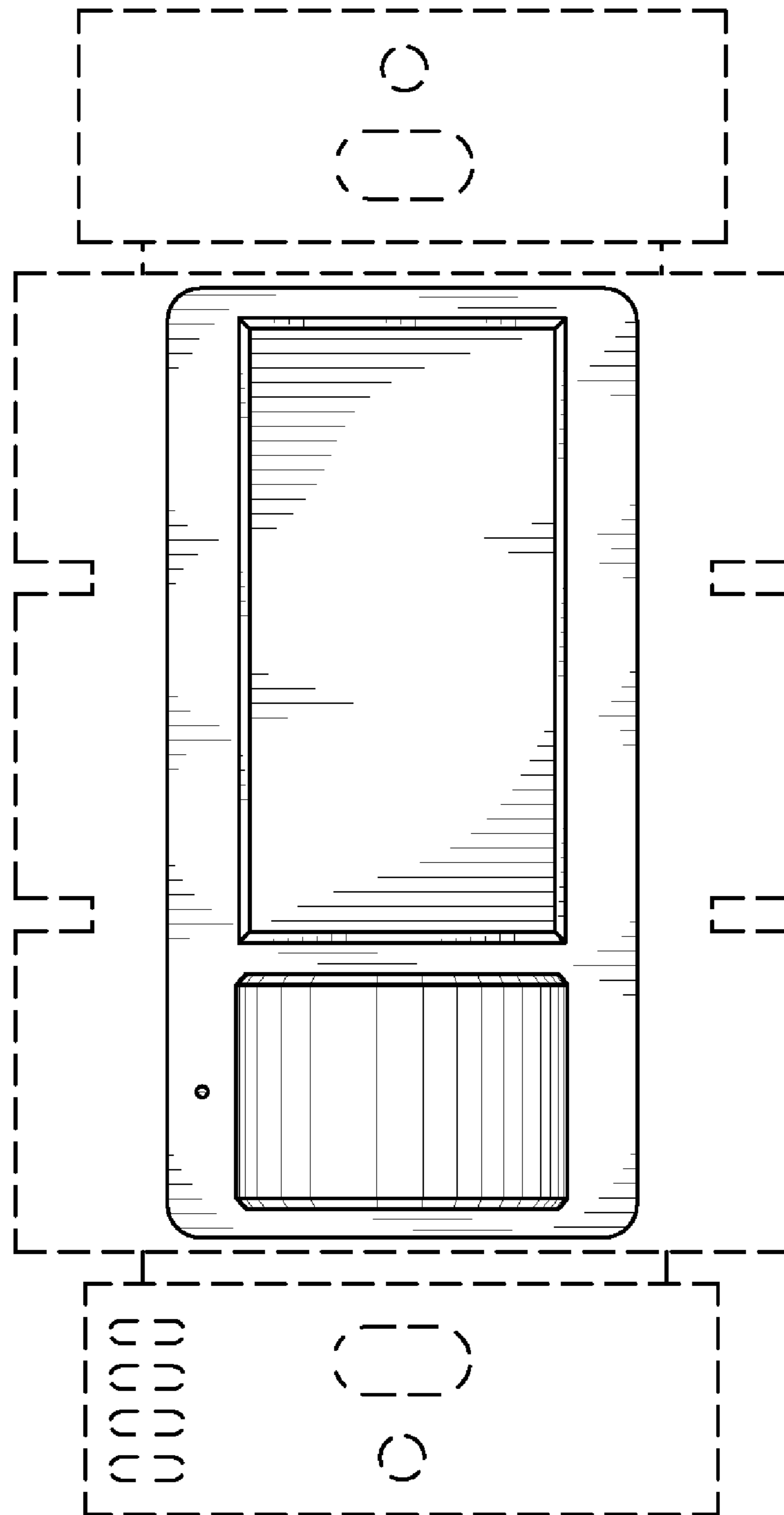

Fig. 42

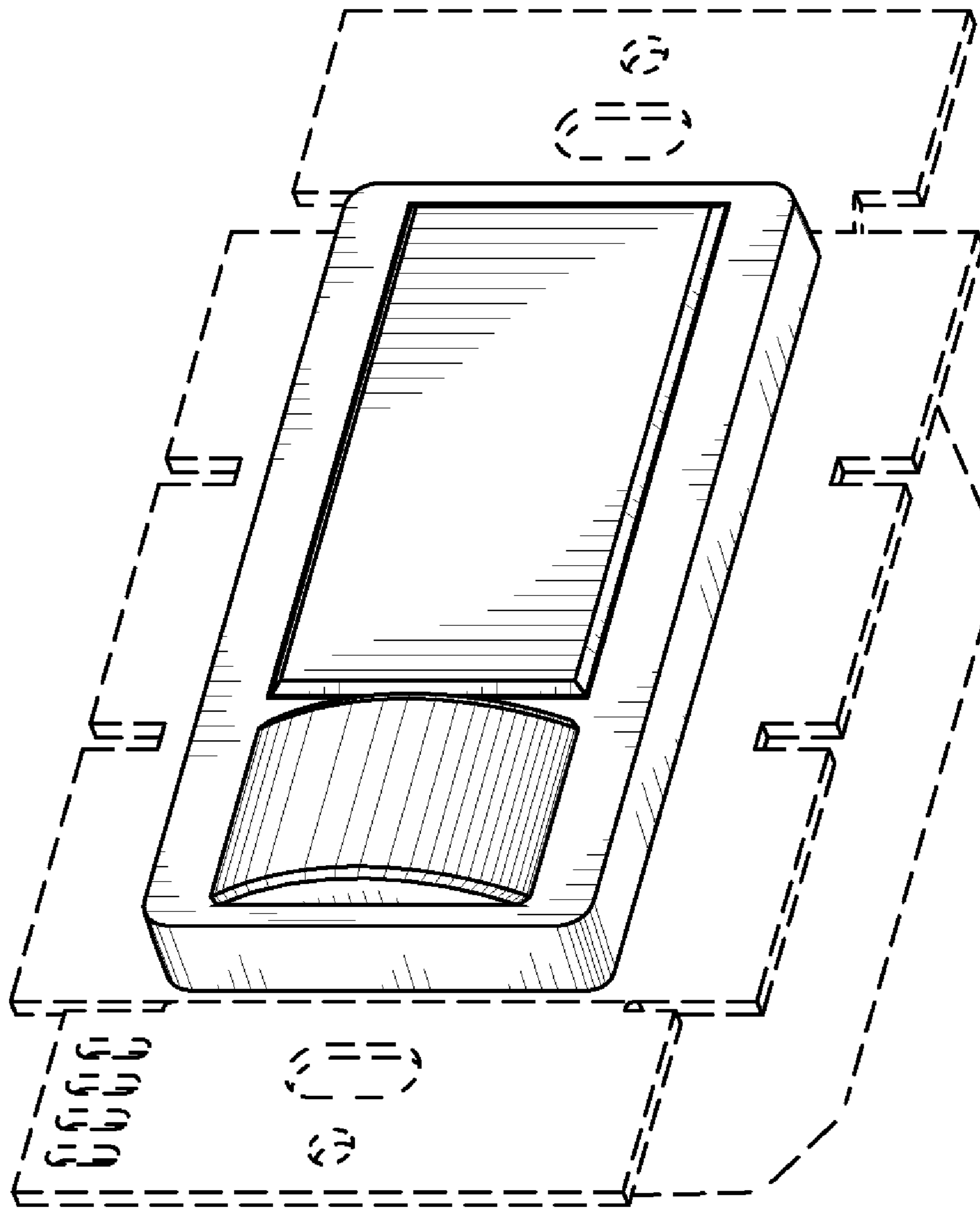

Fig. 43



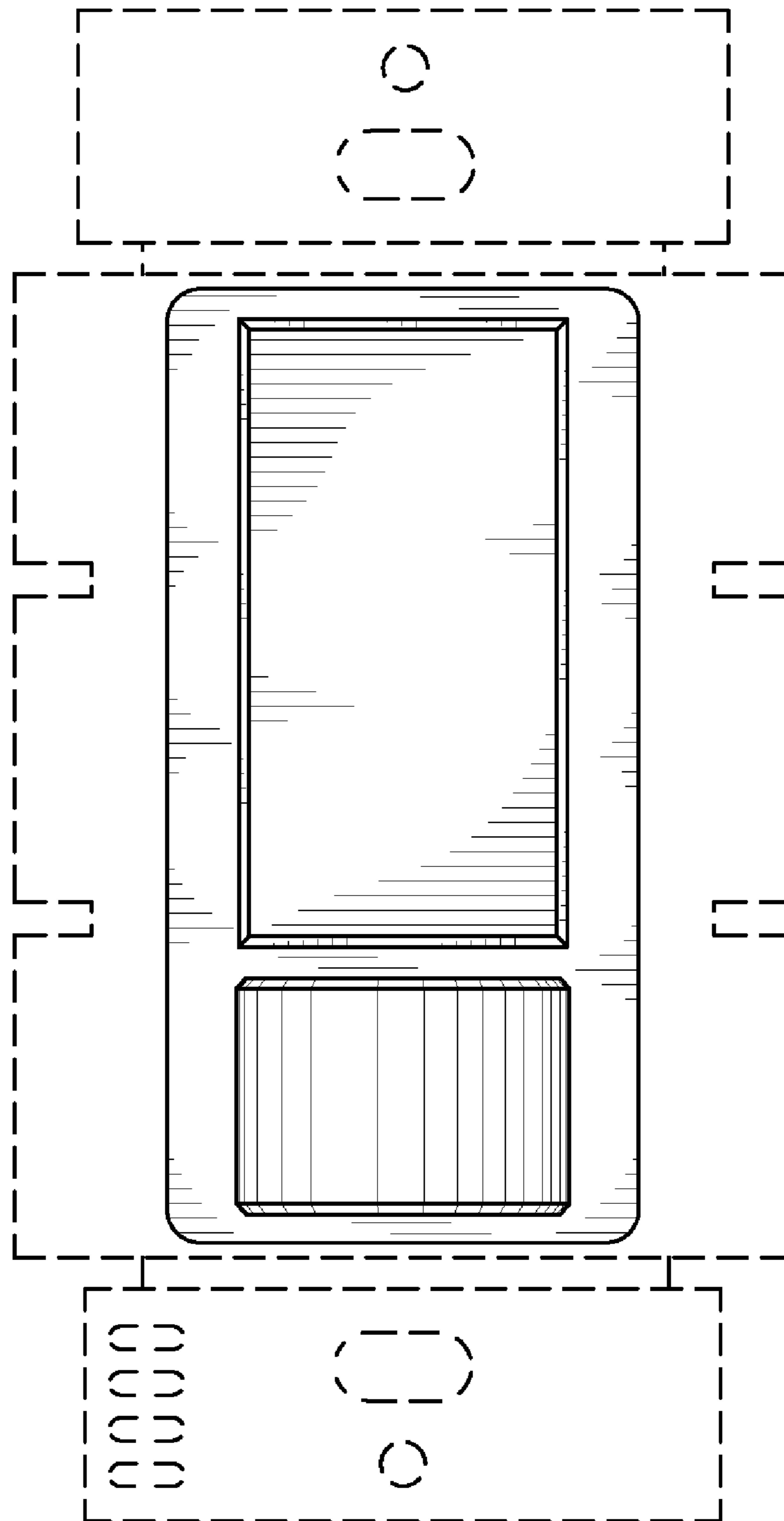

Fig. 44