



US00D595507S

(12) **United States Design Patent**
Chu et al.

(10) **Patent No.:** **US D595,507 S**
(45) **Date of Patent:** **** Jul. 7, 2009**

(54) **LUGGAGE**

(75) Inventors: **David Ching Chi Chu**, New York, NY (US); **Peter Chang-Lin Wu**, Franklin Park, NJ (US)

(73) Assignee: **Tumi, Inc.**, New York, NY (US)

(**) Term: **14 Years**

(21) Appl. No.: **29/322,345**

(22) Filed: **Aug. 1, 2008**

(51) **LOC (9) Cl.** **03-01**

(52) **U.S. Cl.** **D3/319**

(58) **Field of Classification Search** D3/279
See application file for complete search history.

(56) **References Cited**

U.S. PATENT DOCUMENTS

D280,866 S *	10/1985	Bomes et al.	D3/287
D308,132 S *	5/1990	Kim	D3/279
D308,134 S *	5/1990	Kim	D3/279
D308,135 S *	5/1990	Kim	D3/279
D322,357 S *	12/1991	King	D3/279
D327,575 S *	7/1992	Nordstrom	D3/279
D360,978 S *	8/1995	Willard et al.	D3/301
D396,144 S *	7/1998	Farmer	D3/287
D414,932 S *	10/1999	Platte, III	D3/276
D465,086 S *	11/2002	Watts	D3/290
D472,385 S *	4/2003	Bauer	D3/279
D476,154 S *	6/2003	Lovett	D3/279
D481,204 S *	10/2003	Rada	D3/279
D552,349 S *	10/2007	Greiner	D3/279

OTHER PUBLICATIONS

Tumi Townhouse—Chapel Wheeled Garment Case, used as informal images for discussion between attorney of record and (see Office Action). Downloaded Mar. 27, 2009 at <http://www.tumi.com/townhouse/chapel-wheeled-garment-case/>.*

Photographs of various luggage samples from Jun. 2007.

Luggage photographs alleged by Jack Georges to be from 1997 and 1998.

Schlesinger luggage photographs from a 1993 catalog.

Dakota Adventure luggage from a 1998 catalog.

* cited by examiner

Primary Examiner—Philip S Hyder

Assistant Examiner—Roselynn Cody

(74) *Attorney, Agent, or Firm*—Baker Botts L.L.P.

(57) **CLAIM**

The ornamental design for luggage, as shown and described.

DESCRIPTION

FIG. 1 is a perspective view of the luggage, embodying our new design.

FIG. 2 is front view of the luggage of FIG. 1.

FIG. 3 is a rear view of the luggage of FIG. 1.

FIG. 4 is left side view of the luggage of FIG. 1.

FIG. 5 is right side view of the luggage of FIG. 1.

FIG. 6 is a top view of the luggage of FIG. 1; and,

FIG. 7 is a bottom view of the luggage of FIG. 1.

The broken lines shown on the straps and front trim of the luggage depict stitching and form part of the claimed design. All other broken lines in the figures are illustrative of environment and form no part of the claimed design.

1 Claim, 5 Drawing Sheets





FIG. 1

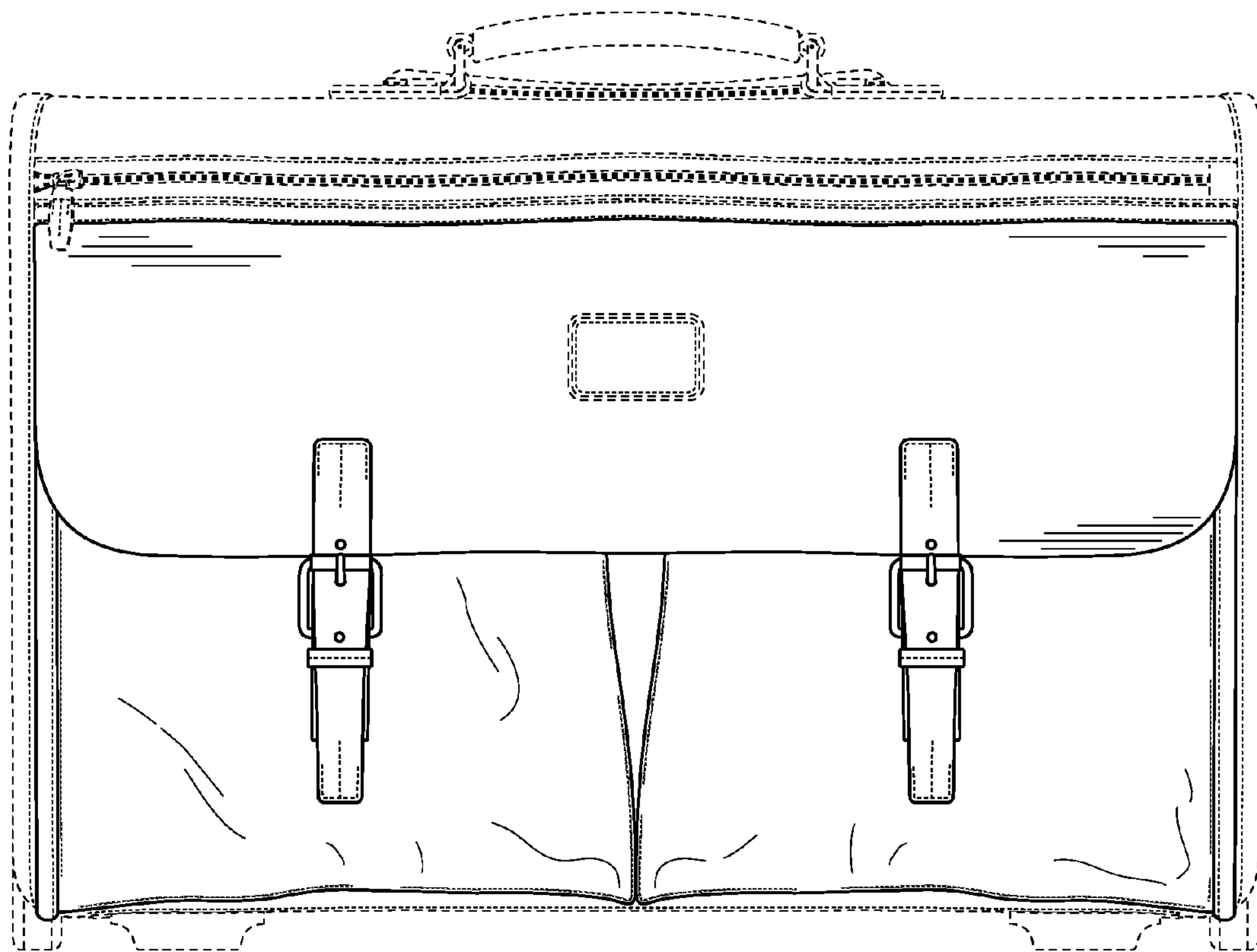

FIG. 2

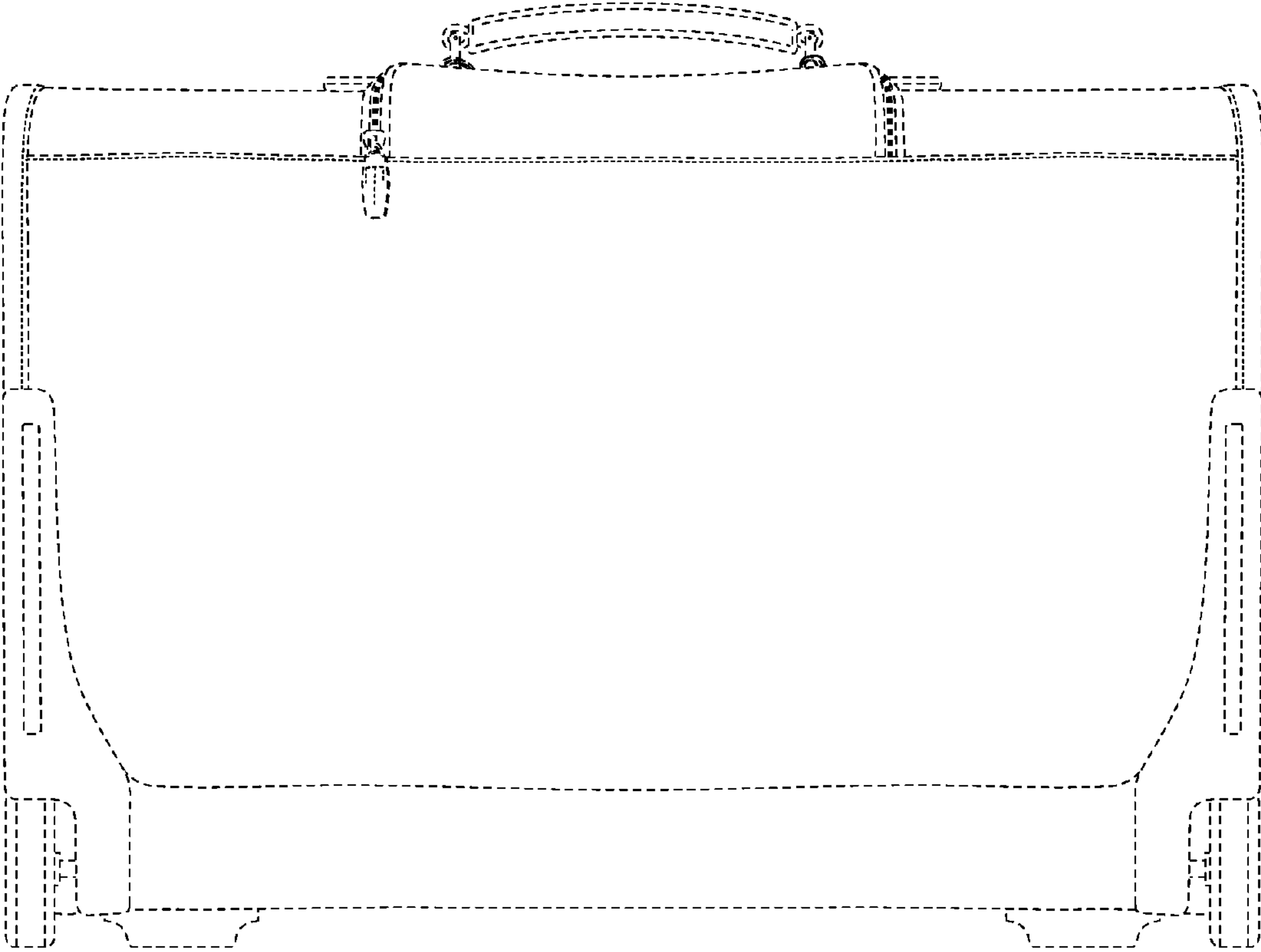

FIG. 3



FIG. 4



FIG. 5

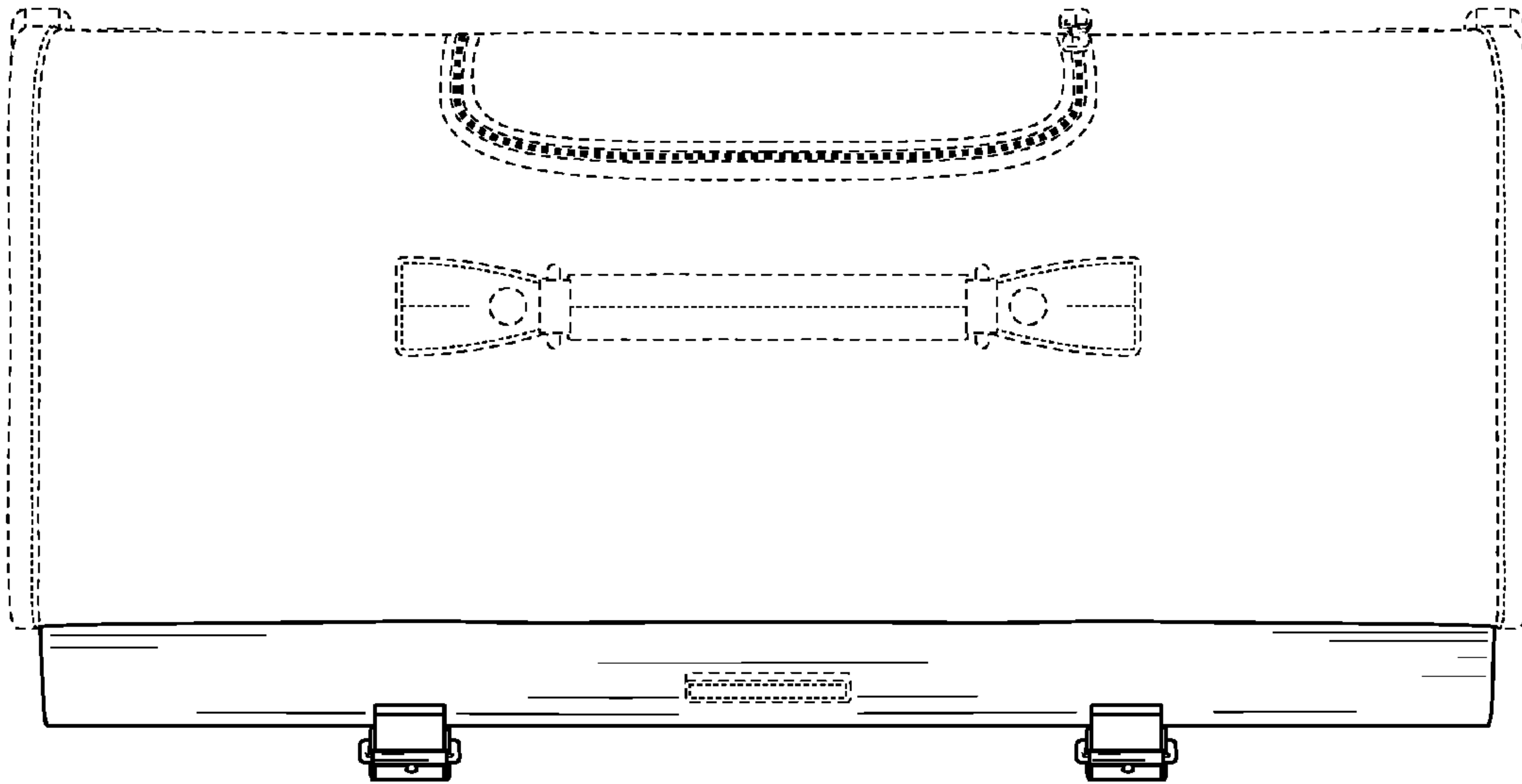

FIG. 6

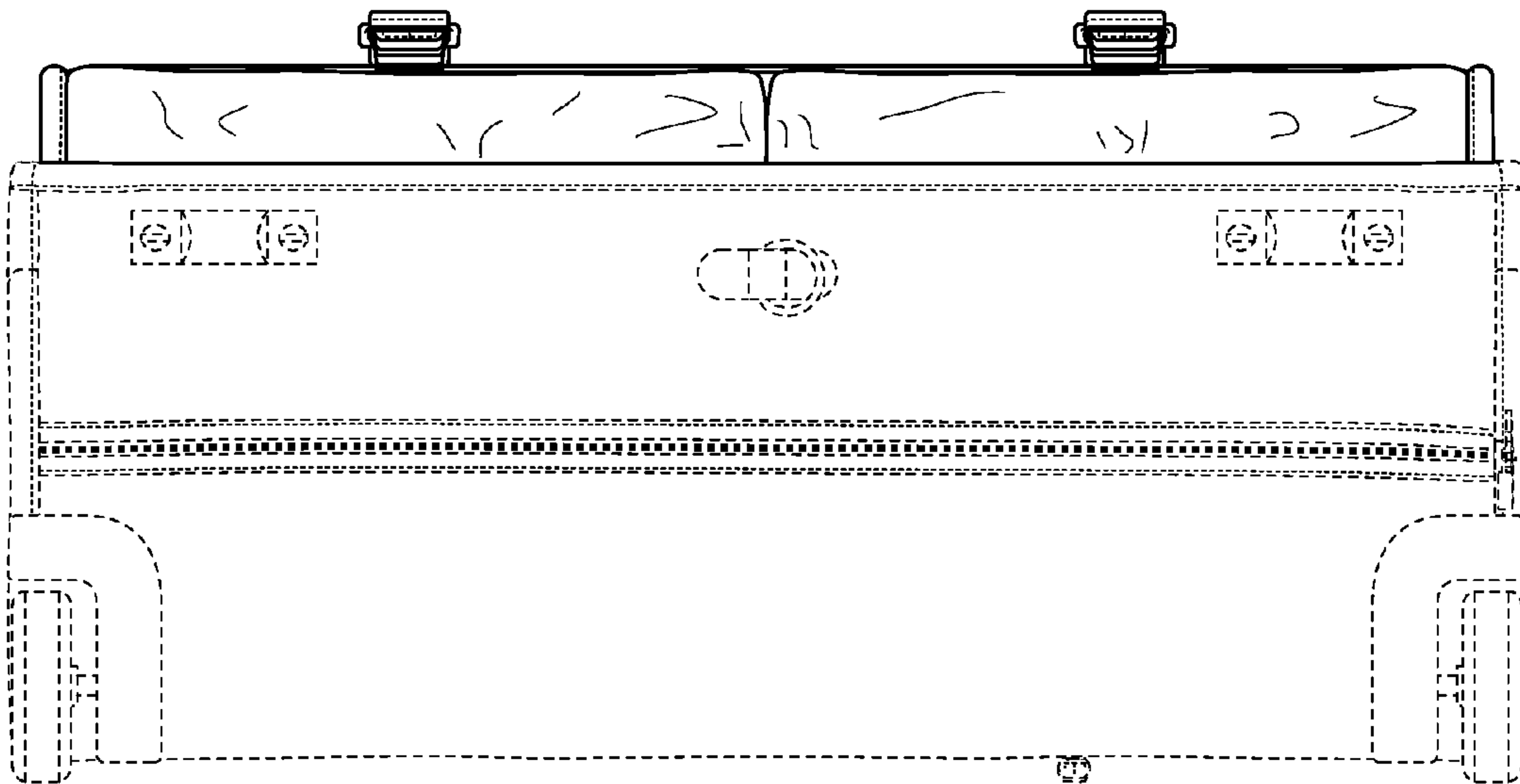

FIG. 7