



US00D595210S

(12) **United States Design Patent**  
**Cazals**

(10) **Patent No.:** **US D595,210 S**  
(45) **Date of Patent:** **\*\* Jun. 30, 2009**

(54) **AIRCRAFT TAIL**

(75) Inventor: **Olivier Cazals**, Daux (FR)  
(73) Assignee: **Airbus France SAS**, Toulouse Cedex (FR)

(\*\*) Term: **14 Years**  
(21) Appl. No.: **29/306,406**  
(22) Filed: **Apr. 9, 2008**

(51) **LOC (9) Cl.** ..... **12-07**  
(52) **U.S. Cl.** ..... **D12/345**  
(58) **Field of Classification Search** ..... D12/319, D12/326-329, 333, 337, 340-345; D21/447-448, D21/450; 244/4 R, 5, 6, 7 R, 7 A, 7 B, 7 C, 244/21, 117 R, 119, 123.1, 129.1, 130  
See application file for complete search history.

(56) **References Cited**

**U.S. PATENT DOCUMENTS**

D397,989 S	*	9/1998	Al-Sabah	.....	D12/319
D426,804 S	*	6/2000	Birrenbach	.....	D12/319
D581,342 S	*	11/2008	Cazals	.....	D12/345
D581,343 S	*	11/2008	Cazals	.....	D12/345

**OTHER PUBLICATIONS**

- U.S. Appl. No. 29/305,899; Title: Elements of an Aircraft Tail, filed Mar. 29, 2008.
- U.S. Appl. No. 29/306,053; Title: Elements of an Aircraft Tail, filed Apr. 1, 2008.
- U.S. Appl. No. 29/306,060; Title: Element of an Aircraft, filed Apr. 1, 2008.
- U.S. Appl. No. 29/306,062; Title: Element of an Aircraft Body, filed Apr. 1, 2008.
- U.S. Appl. No. 29/306,066; Title: Elements of an Aircraft Tail, filed Apr. 1, 2008.
- U.S. Appl. No. 29/306,067; Title: Elements of an Aircraft Tail, filed Apr. 1, 2008.
- U.S. Appl. No. 29/306,068; Title: Elements of an Aircraft Tail, filed Apr. 1, 2008.
- U.S. Appl. No. 29/306,078; Title: Elements of an Aircraft Tail, filed Apr. 1, 2008.
- U.S. Appl. No. 29/306,079; Title: Elements of an Aircraft Tail, filed Apr. 1, 2008.

- U.S. Appl. No. 29/306,412; Title: Elements of an Aircraft Tail, filed Apr. 9, 2008.
- U.S. Appl. No. 29/306,405; Title: Elements of an Aircraft Tail, filed Apr. 9, 2008.
- U.S. Appl. No. 29/306,407; Title: Elements of an Aircraft Tail, filed Apr. 9, 2008.
- U.S. Appl. No. 29/306,408; Title: Elements of an Aircraft Tail, filed Apr. 9, 2008.
- U.S. Appl. No. 29/306,409; Title: Elements of an Aircraft Tail, filed Apr. 9, 2008.
- U.S. Appl. No. 29/306,410; Title: Elements of an Aircraft Tail, filed Apr. 9, 2008.

\* cited by examiner

*Primary Examiner*—Ian Simmons  
*Assistant Examiner*—Dana L Sipos  
(74) *Attorney, Agent, or Firm*—Osler, Hoskin & Harcourt LLP

(57) **CLAIM**

The ornamental design for an aircraft tail, as shown and described.

**DESCRIPTION**

FIG. 1 is a partial top, front, right side perspective view of an aircraft tail according to my new design

FIG. 2 is a partial top, rear, left side perspective view thereof;

FIG. 3 is a top, front, right side perspective view of the aircraft tail of FIG. 1;

FIG. 4 is a rear elevation view thereof;

FIG. 5 is a top plan view thereof;

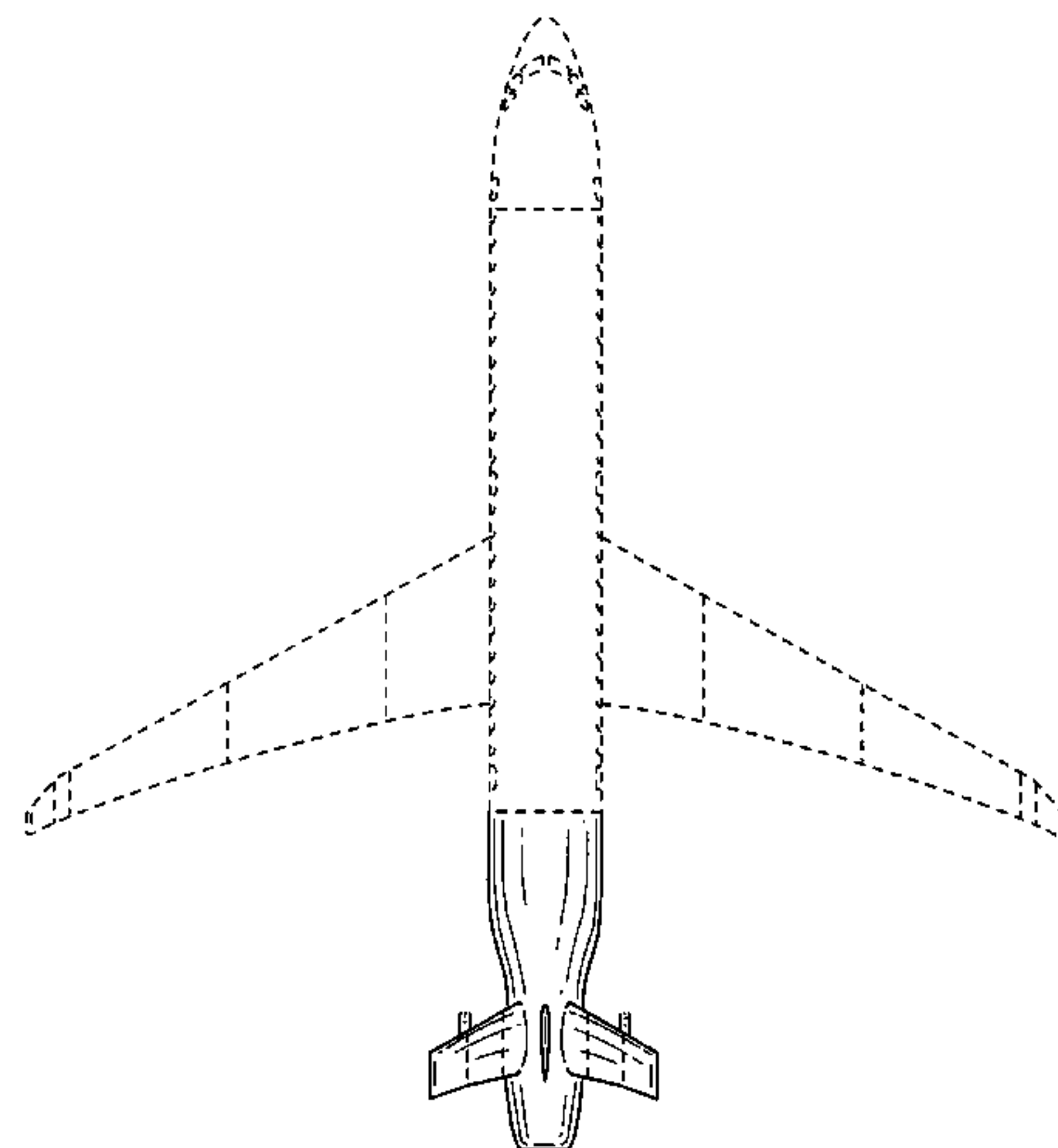
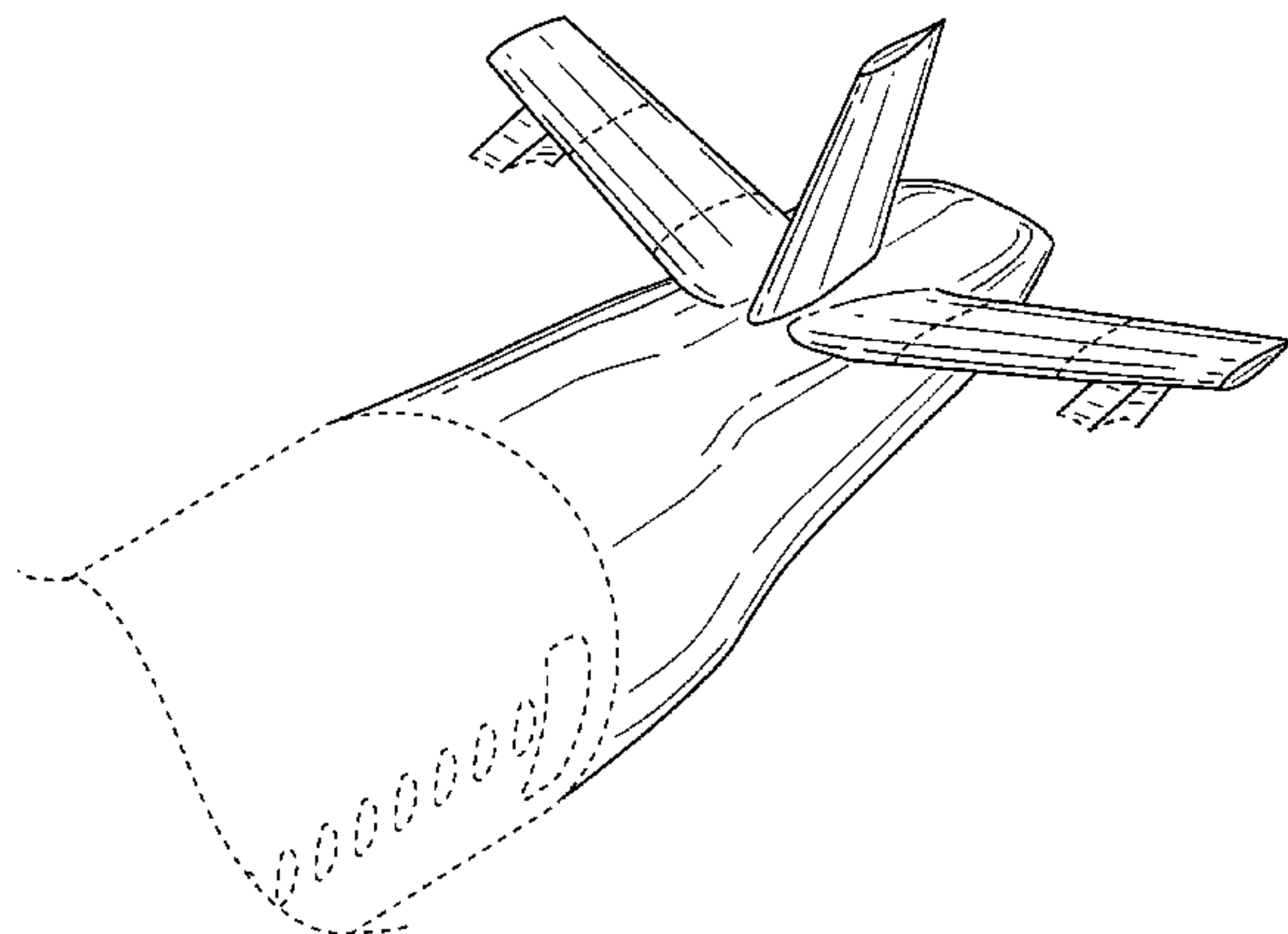
FIG. 6 is a bottom plan view thereof;

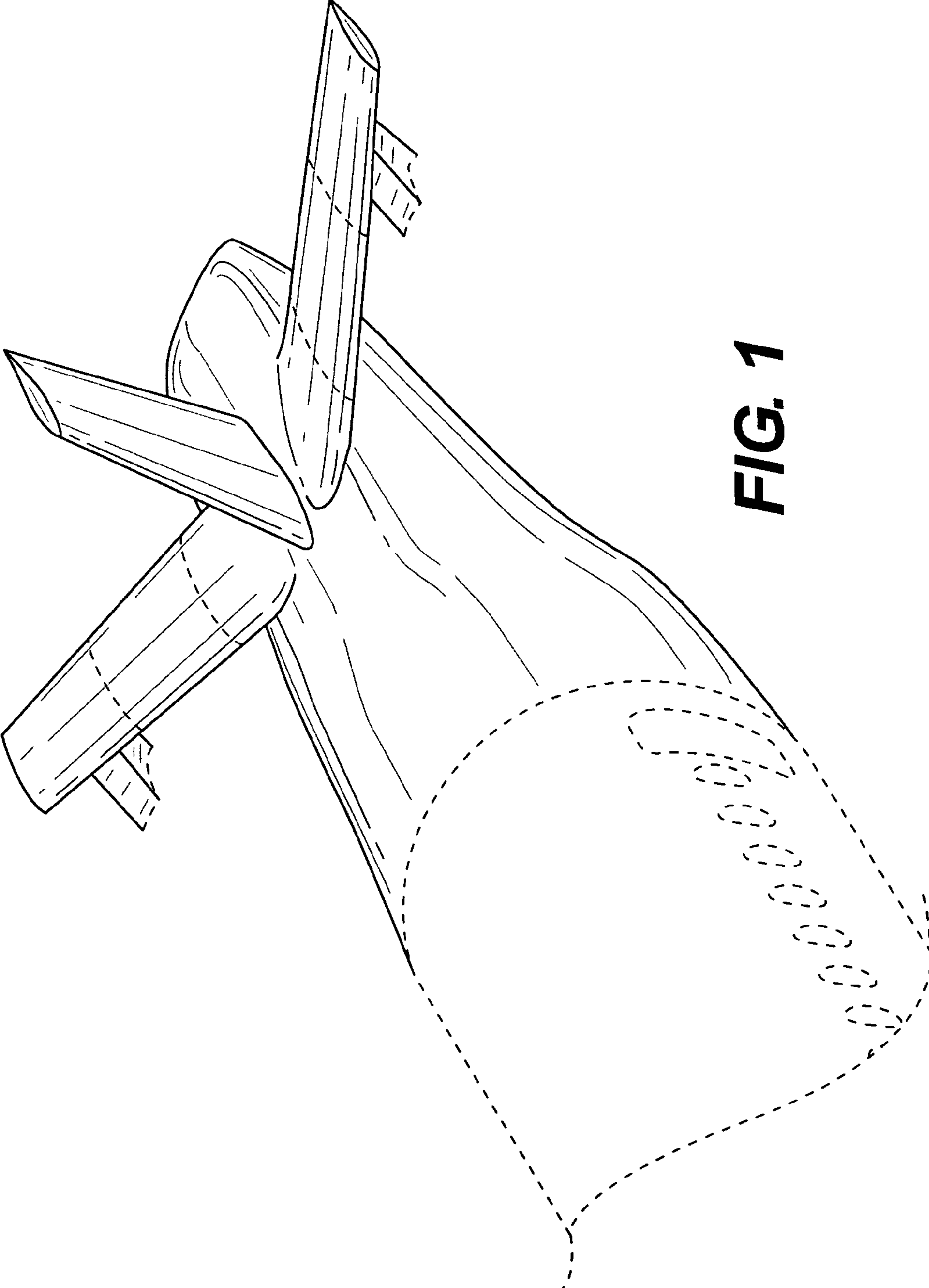
FIG. 7 is a left side elevation view thereof, the right side elevation view being a mirror image; and,

FIG. 8 is a top, front, right side perspective view thereof, showing unclaimed engines in place.

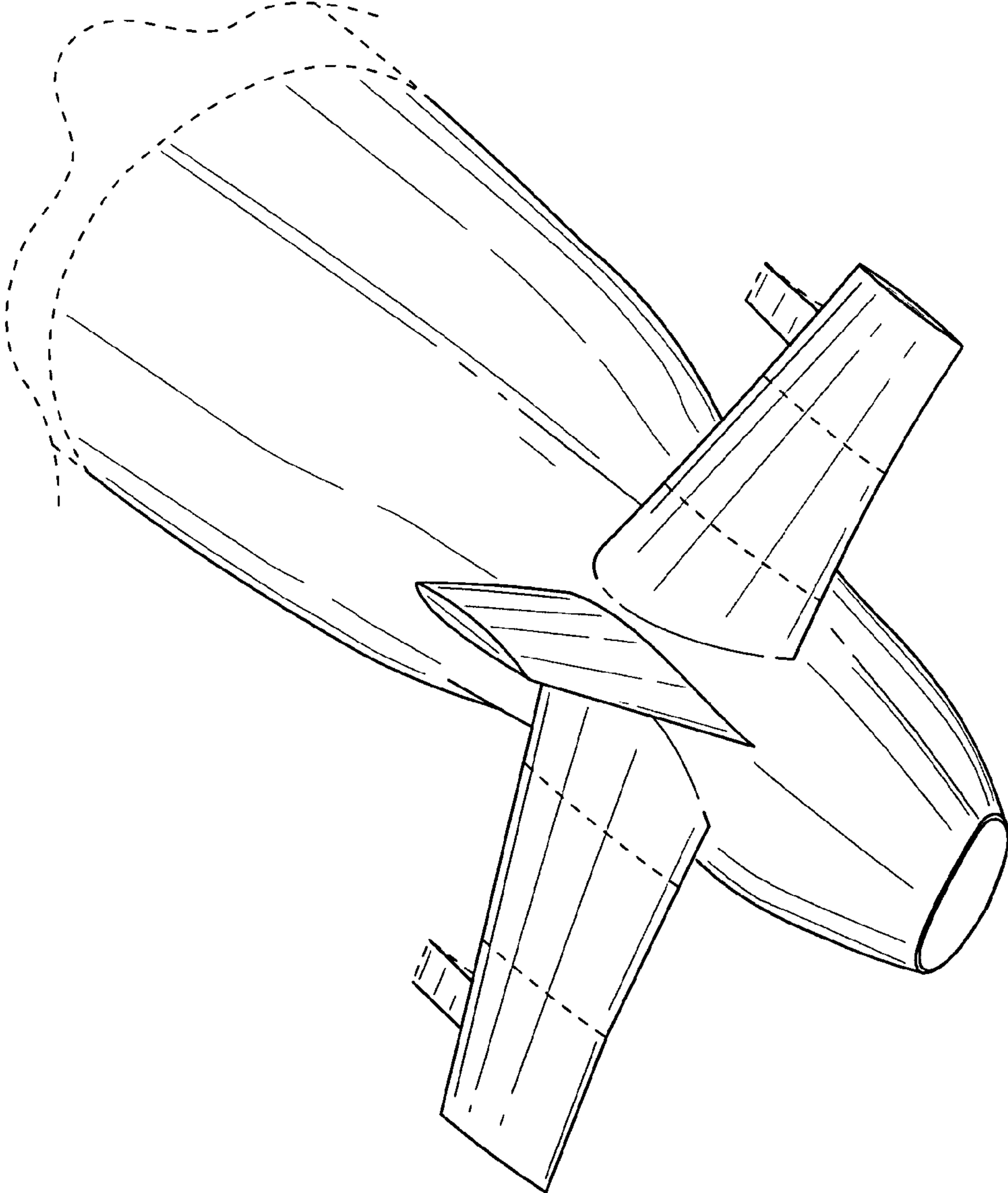
Throughout the figures, broken lines showing environment or structure are for illustrative purposes only and form no part of the claimed design.

**1 Claim, 8 Drawing Sheets**

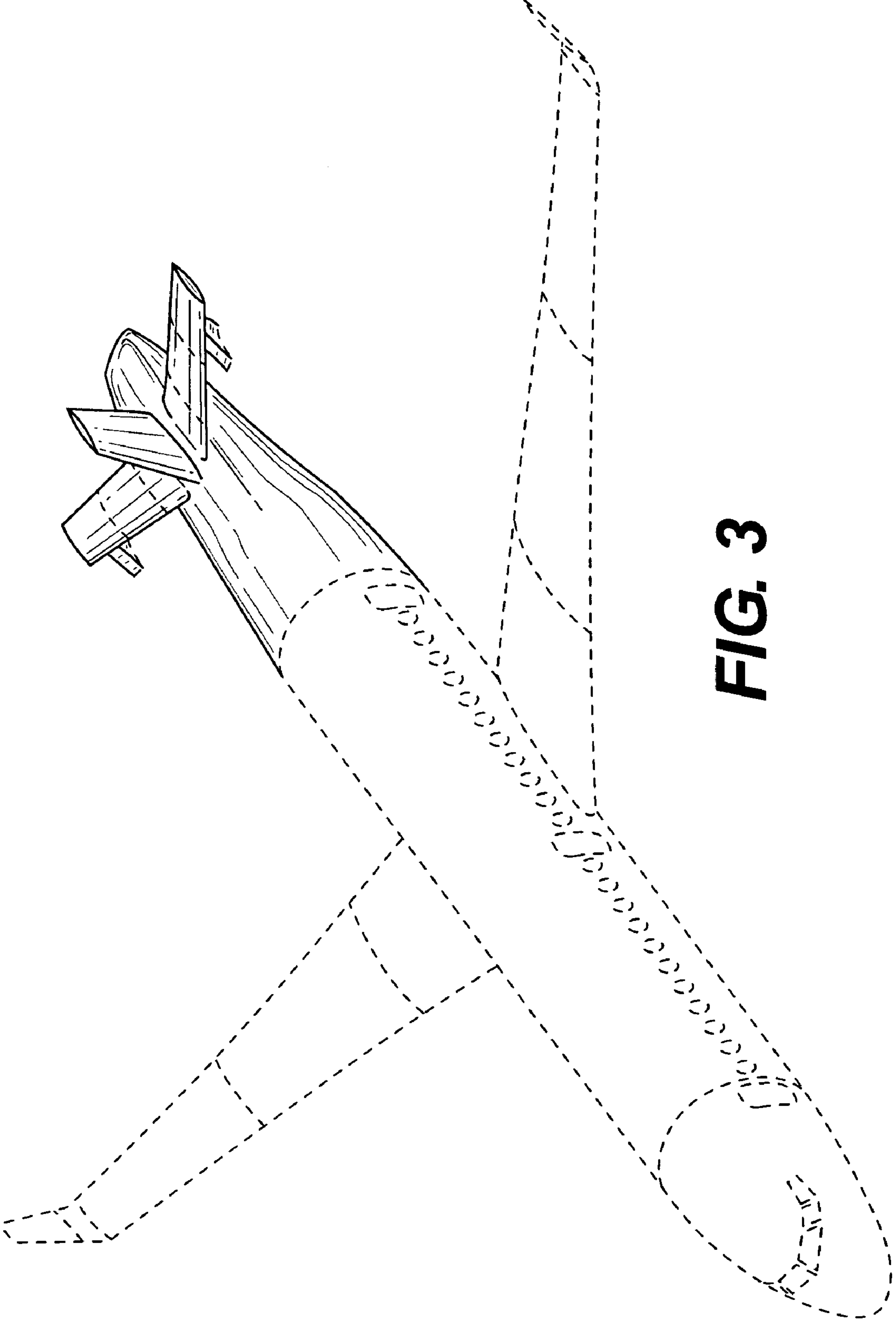




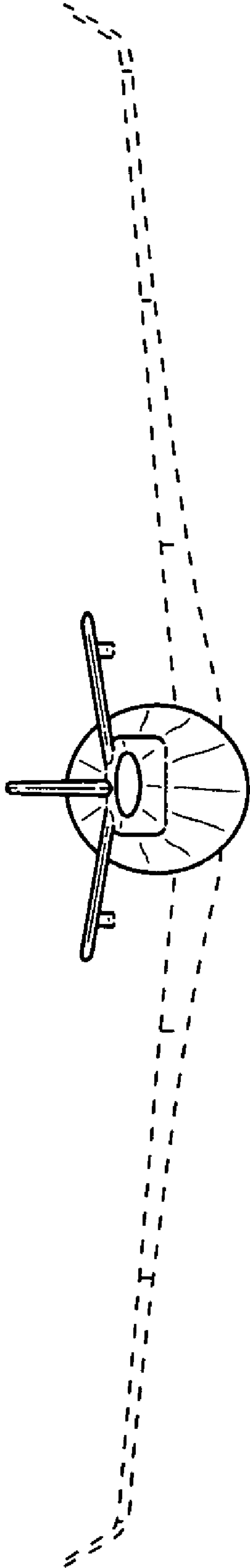
**FIG. 1**



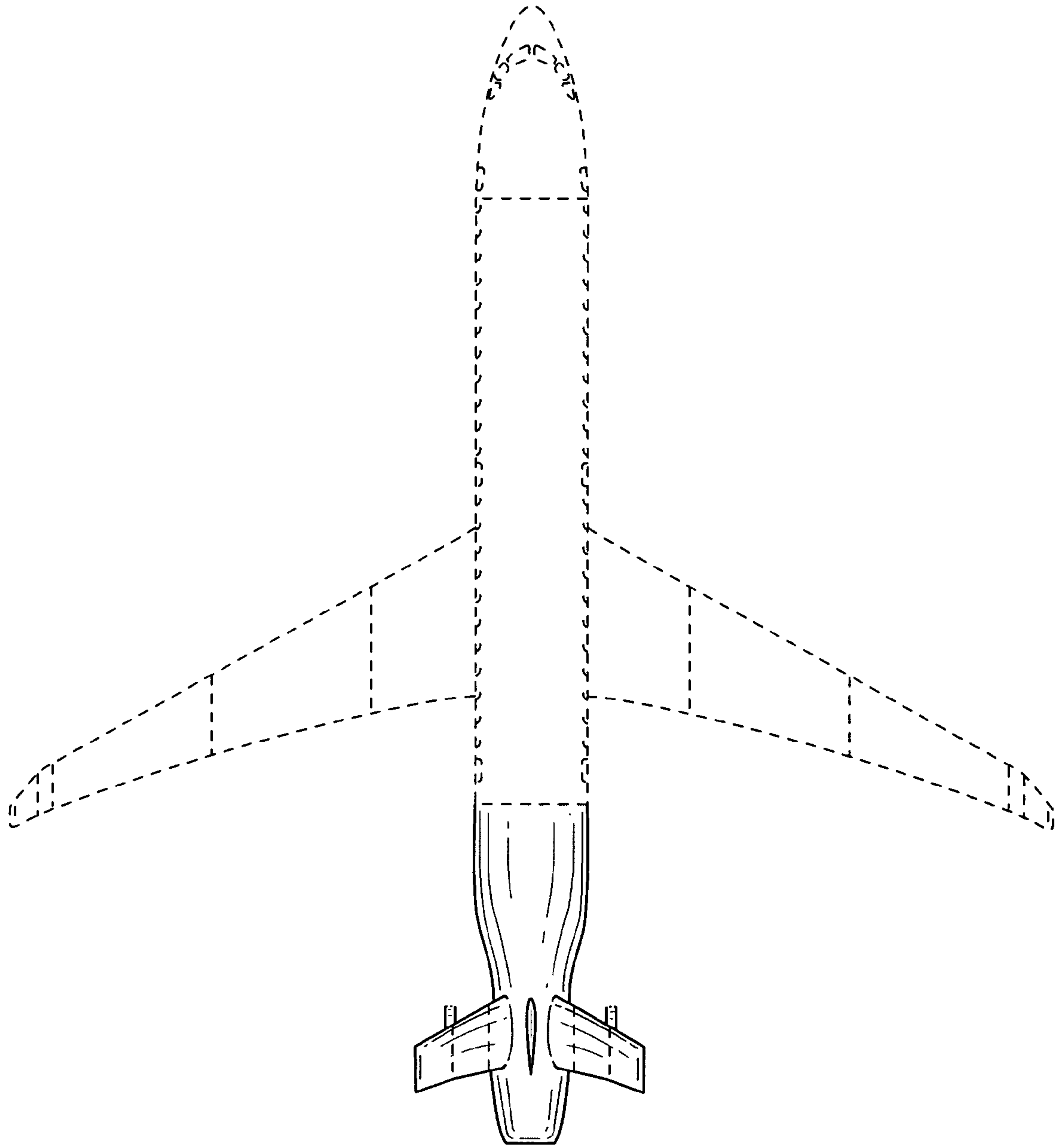
**FIG. 2**



**FIG. 3**

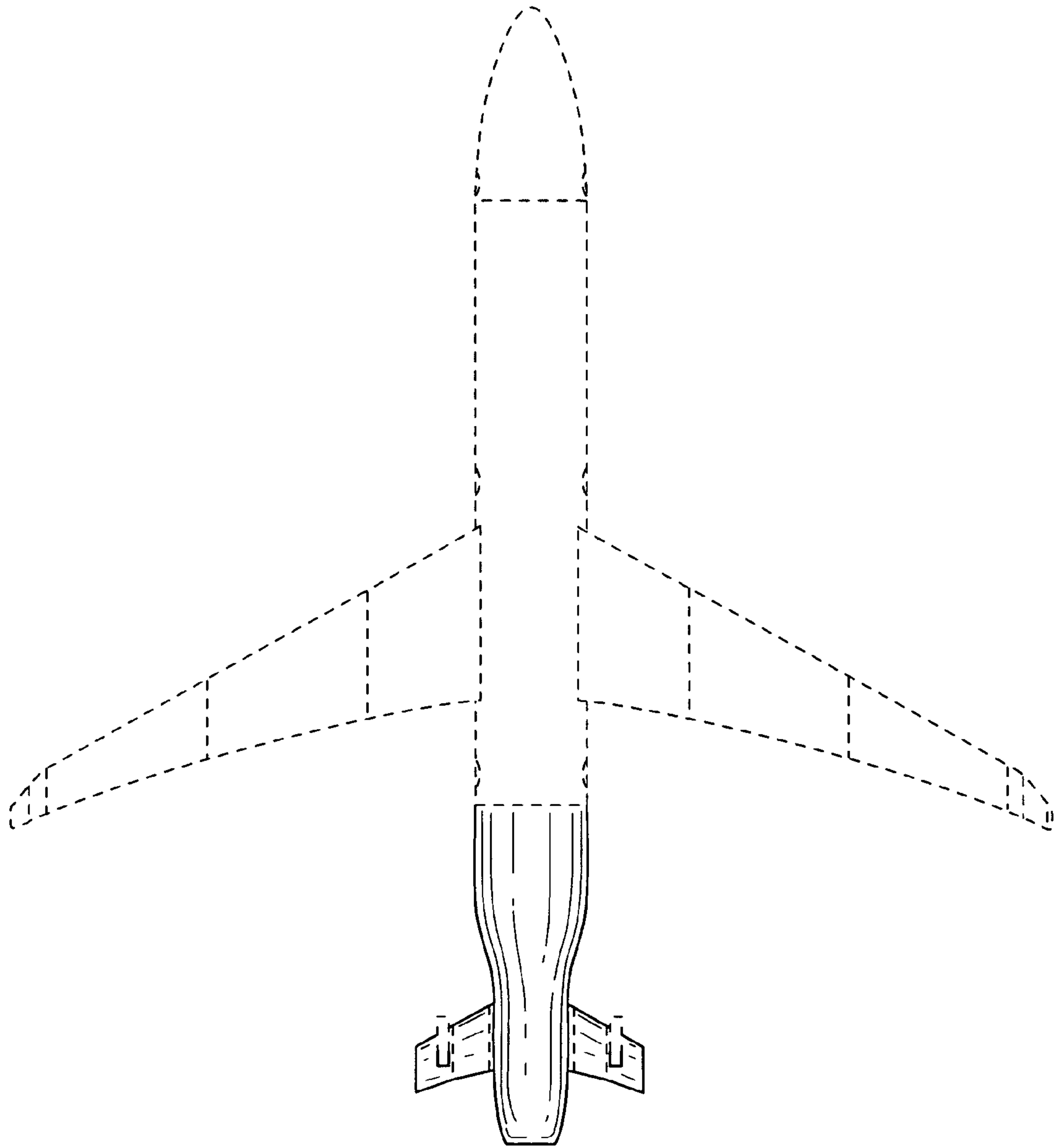


**FIG. 4**

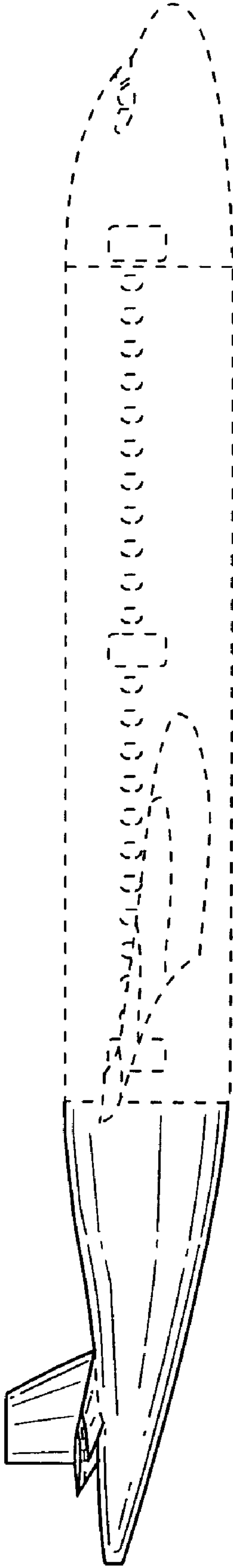


**FIG. 5**



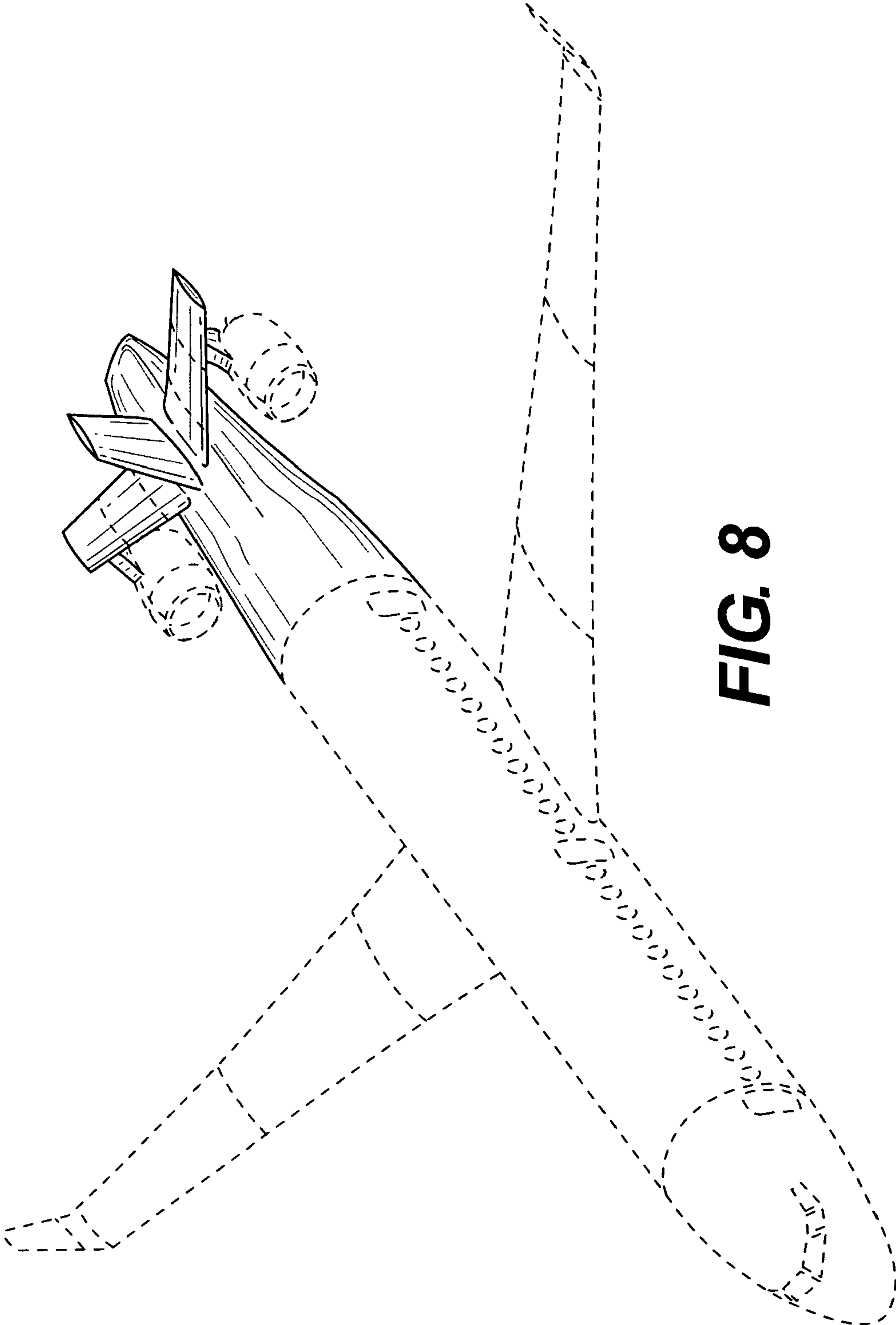


**FIG. 6**



**FIG. 7**





**FIG. 8**