



US00D595187S

(12) **United States Design Patent**
Schroeder et al.

(10) **Patent No.:** **US D595,187 S**
(45) **Date of Patent:** **** Jun. 30, 2009**

(54) **VEHICLE FENDER**

(75) Inventors: **Anthony M. Schroeder**, Huntington Beach, CA (US); **Nicholas Renner**, Irvine, CA (US); **Asao Itaya**, Gardena, CA (US); **Jessica Vera**, Torrance, CA (US); **Hideaki Yamazumi**, Asaka (JP); **Hiroyuki Miyazaki**, Redondo Beach, CA (US); **Stephen Hlopick**, Marysville, OH (US); **Darin D. King**, Raymond, OH (US); **Daniel Thomas Sellars**, West Liberty, OH (US)

(73) Assignee: **Honda Motor Co., Ltd.**, Tokyo (JP)

(**) Term: **14 Years**

(21) Appl. No.: **29/281,543**

(22) Filed: **Jun. 26, 2007**

(51) **LOC (9) Cl.** **12-11**

(52) **U.S. Cl.** **D12/107; D12/181**

(58) **Field of Classification Search** D12/3, D12/86, 87, 107, 110, 126, 181, 182, 184, D12/186; 180/225, 229, 233, 311, 312, 315, 180/227; 296/78.1, 198; 280/152.1-152.3, 280/847-851; 293/102, 105

See application file for complete search history.

(56) **References Cited**

U.S. PATENT DOCUMENTS

D512,001 S * 11/2005 Kato et al. D12/107

D515,978 S * 2/2006 Luh D12/107
D517,450 S * 3/2006 Wu D12/107
D529,413 S * 10/2006 Basset et al. D12/107
D550,590 S * 9/2007 Basset et al. D12/107

* cited by examiner

Primary Examiner—Cathron C Brooks

Assistant Examiner—Linda Brooks

(74) *Attorney, Agent, or Firm*—Plumsea Law Group, LLC; Mark E. Duell

(57) **CLAIM**

The ornamental design for a vehicle fender, as shown and described.

DESCRIPTION

FIG. 1 is a frontal perspective view of a vehicle fender showing our new design;

FIG. 2 is a top plan view thereof; and,

FIG. 3 is a perspective view shown on a portion of an all terrain vehicle.

The portions shown in broken line form no part of the claimed design. The underside of the vehicle fender is not shown and forms no part of the claimed design.

1 Claim, 2 Drawing Sheets

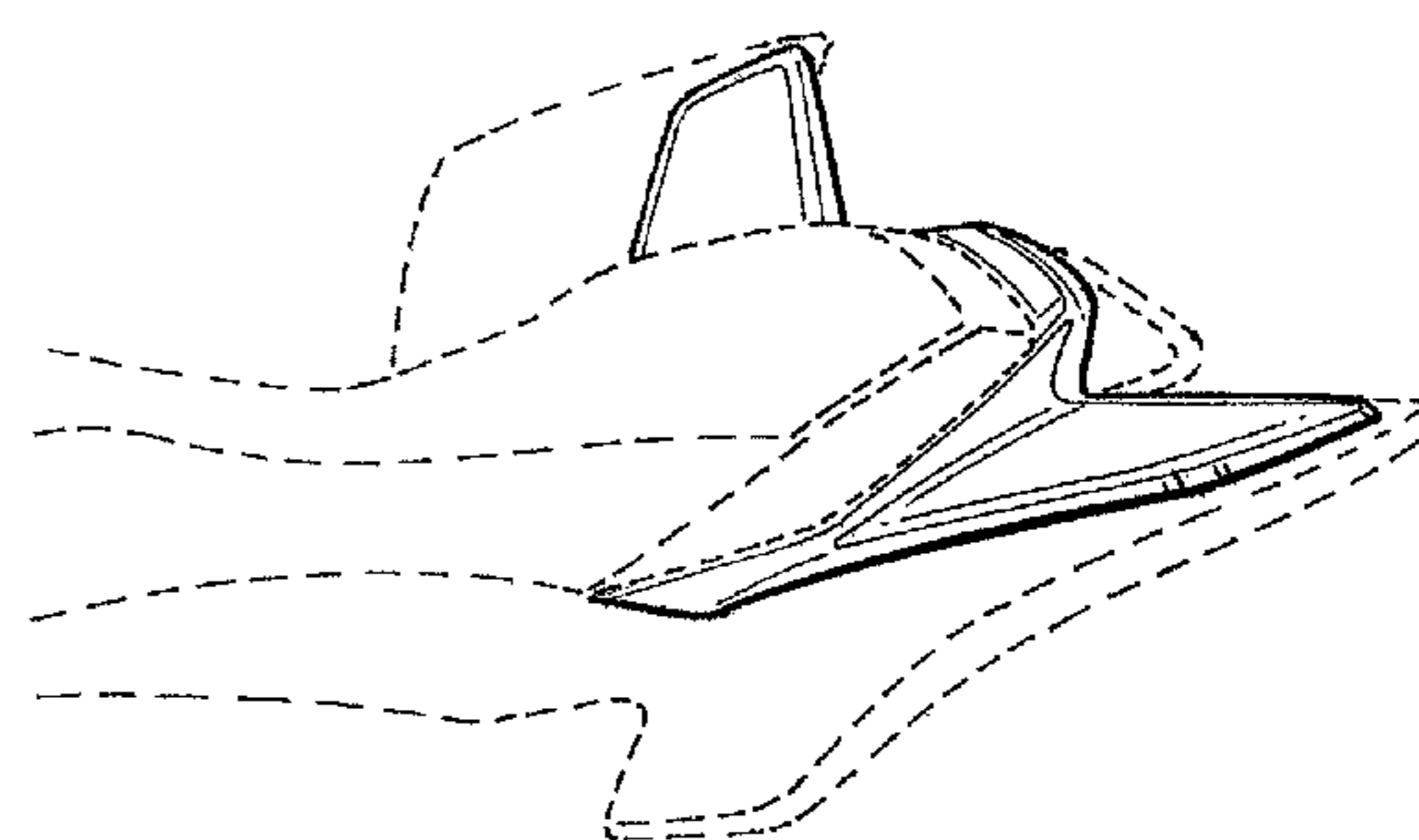
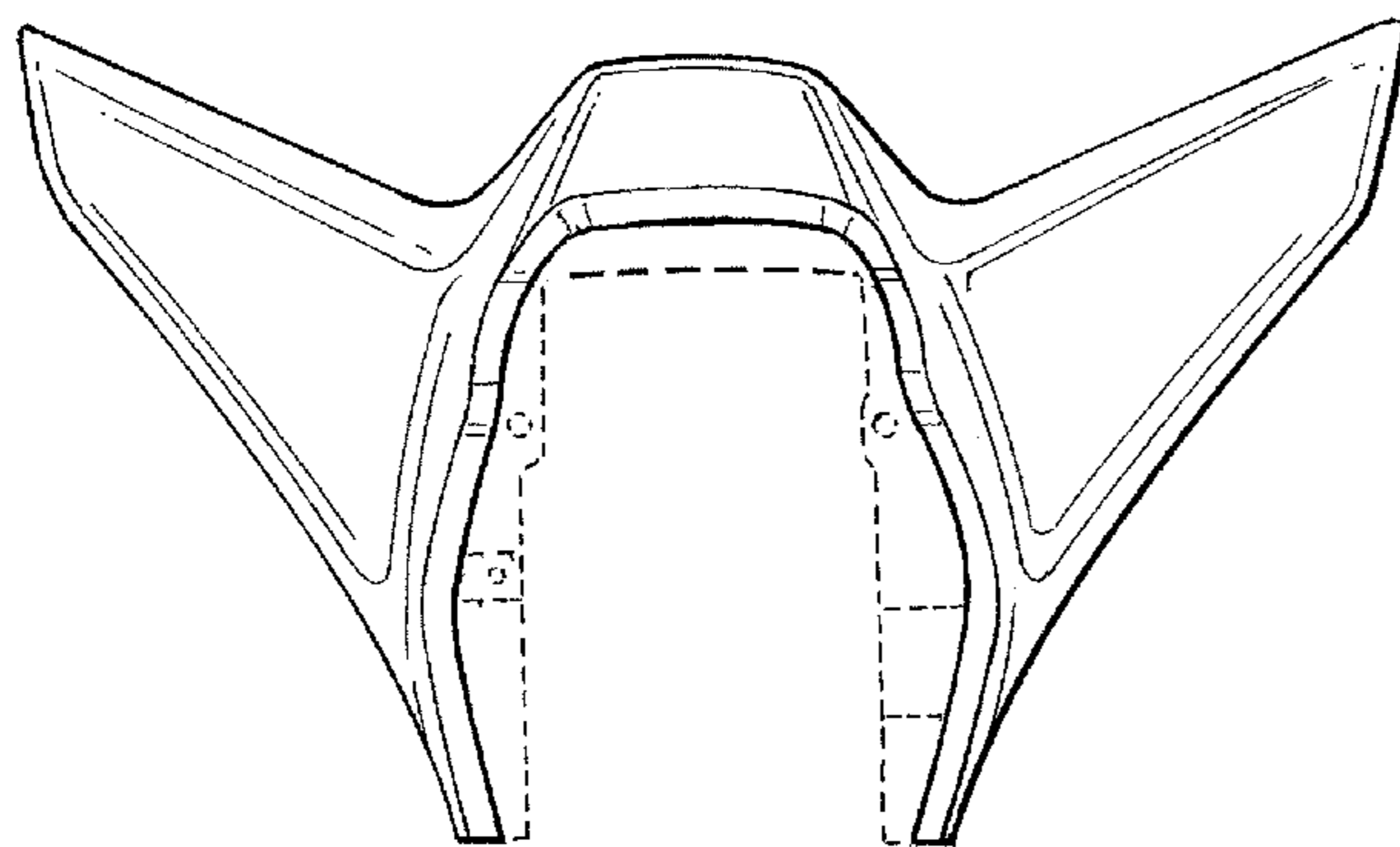

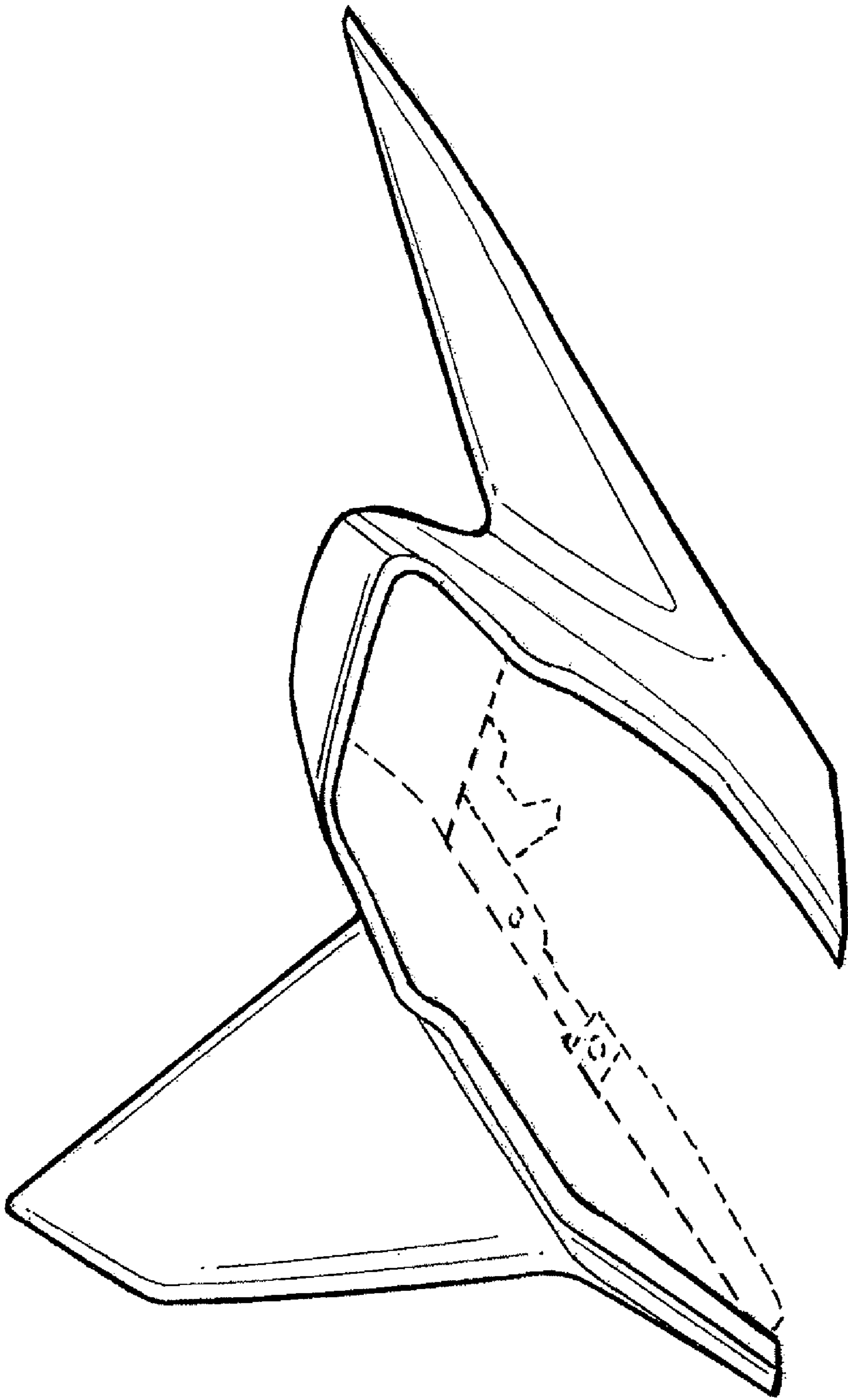

FIG. 1

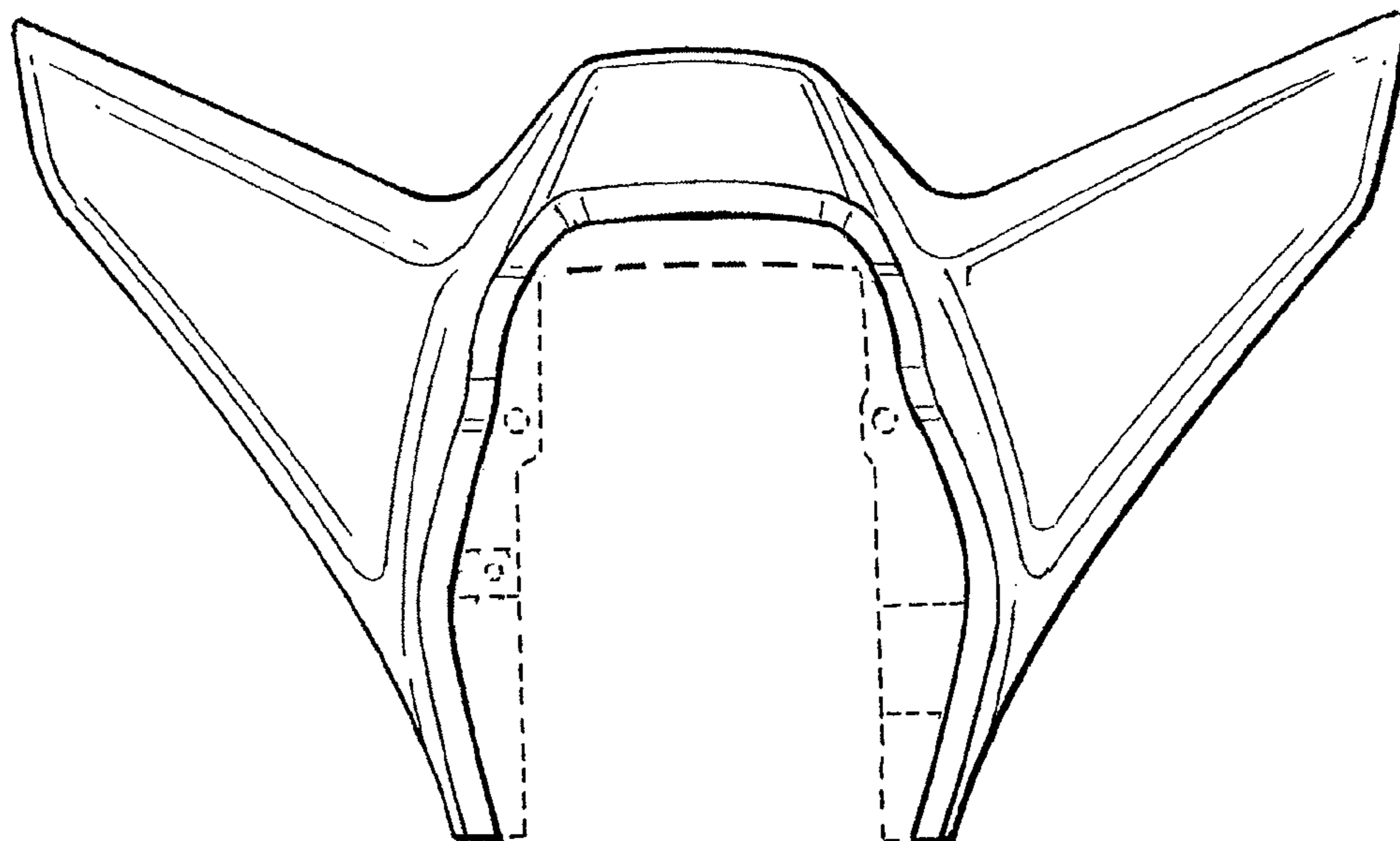

FIG. 2

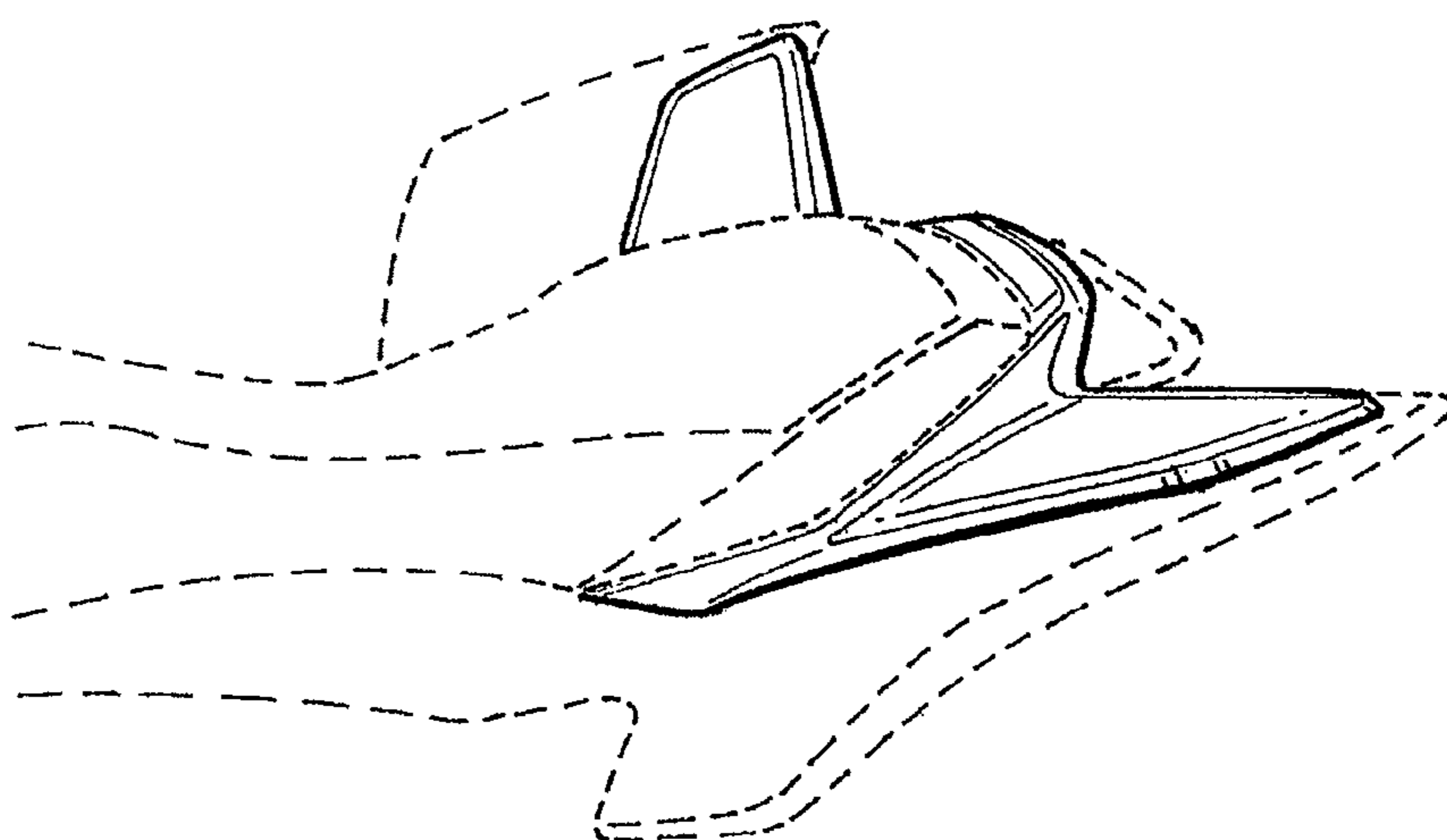

FIG. 3