



US00D594890S

(12) **United States Design Patent**
Jamieson et al.

(10) **Patent No.:** **US D594,890 S**
(45) **Date of Patent:** **** Jun. 23, 2009**

(54) **VEHICLE GRILLE**

(75) Inventors: **Stuart Jamieson**, Chelsea, MI (US);
Freeman Thomas, Laguna Beach, CA
(US); **David Woodhouse**, Newport
Coast, CA (US)

(73) Assignee: **Ford Motor Company**, Dearborn, MI
(US)

(**) Term: **14 Years**

(21) Appl. No.: **29/302,103**

(22) Filed: **Jan. 10, 2008**

(51) **LOC (9) Cl.** **12-16**

(52) **U.S. Cl.** **D16/163**

(58) **Field of Classification Search** D12/163,
D12/169, 400, 167, 90-92, 86, 196, 171,
D12/216; 180/68.6; 296/193.1, 181.1, 181.3;
293/102, 113, 118, 115, 117, 120, 132
See application file for complete search history.

(56) **References Cited**

U.S. PATENT DOCUMENTS

D188,842 S *	9/1960	Dickerson	D12/163
D190,321 S *	5/1961	Niksa	D12/163
D216,686 S *	3/1970	Nerem	D12/163
D505,100 S *	5/2005	Lucas	D12/169
D529,419 S	10/2006	Richards et al.		
D535,222 S *	1/2007	Onoue et al.	D12/163
D551,596 S *	9/2007	Ishizuka et al.	D12/92
D559,742 S *	1/2008	Thomas et al.	D12/163
D561,646 S	2/2008	Thomas et al.		
D561,658 S *	2/2008	Thomas et al.	D12/163
D562,193 S *	2/2008	Platto et al.	D12/163
D563,277 S *	3/2008	Thomas et al.	D12/91
D565,478 S *	4/2008	Abe	D12/163
D569,767 S *	5/2008	Abe et al.	D12/91

OTHER PUBLICATIONS

Roth, Dan; "Detroit Auto Show: Ford Airstream Concept"; Autoblog website article, located at www.autoblog.com/2007/01/07/detroit-auto-show-ford-airstream-concept/; 16 pages; Jan. 7, 2007.

Thomas, David; "2006 L.A. Auto Show: Ford Explorer Fuel Cell"; Cars.com Kicking Tires article, located at http://blogs.cars.com/kickingtires/2006/11/2006_la_auto_sh_4.html; 3 pages; Nov. 28, 2006.

"Ford F-250 Super Chief Concept: A Bold, American Flex Fuel Pickup That Delivers Tomorrow's Fuel Today"; Ford Motor Company Press Release, located at http://media.ford.com/newsroom/release_display.cfm?release=22295; 5 pages; Jan. 8, 2006.

Pund, Daniel, "The Bold and the Brutiful: Ford designs another rear-drive sport sedan concept," Edmunds website article, located at <http://www.edmunds.com/insideline/do/Features/articleId=118988>; 2 pages; Dec. 30, 2006.

"2008 Explorer Maintains Leadership Among Midsize SUVs With Unmatched Features And Equipment"; Ford press release posted on Zer Customs website, located at <http://www.zercustoms.com/news/2008-ford-explorer.html>; 3 pages; Jul. 11, 2007.

* cited by examiner

Primary Examiner—Philip S. Hyder

Assistant Examiner—Cynthia Underwood

(74) *Attorney, Agent, or Firm*—Frank A. MacKenzie; Brooks Kushman P.C.

(57) **CLAIM**

The ornamental design for a vehicle grille, as shown and described.

DESCRIPTION

FIG. 1 is a front view of a vehicle grille in accordance with an embodiment of the present invention;

FIG. 2 is a front/right side perspective view of the vehicle grille of FIG. 1, wherein a front/left side perspective view is a mirror image thereof; and,

FIG. 3 is a right side perspective view of the vehicle grille of FIG. 1, wherein a left side perspective view is a mirror image thereof.

1 Claim, 3 Drawing Sheets

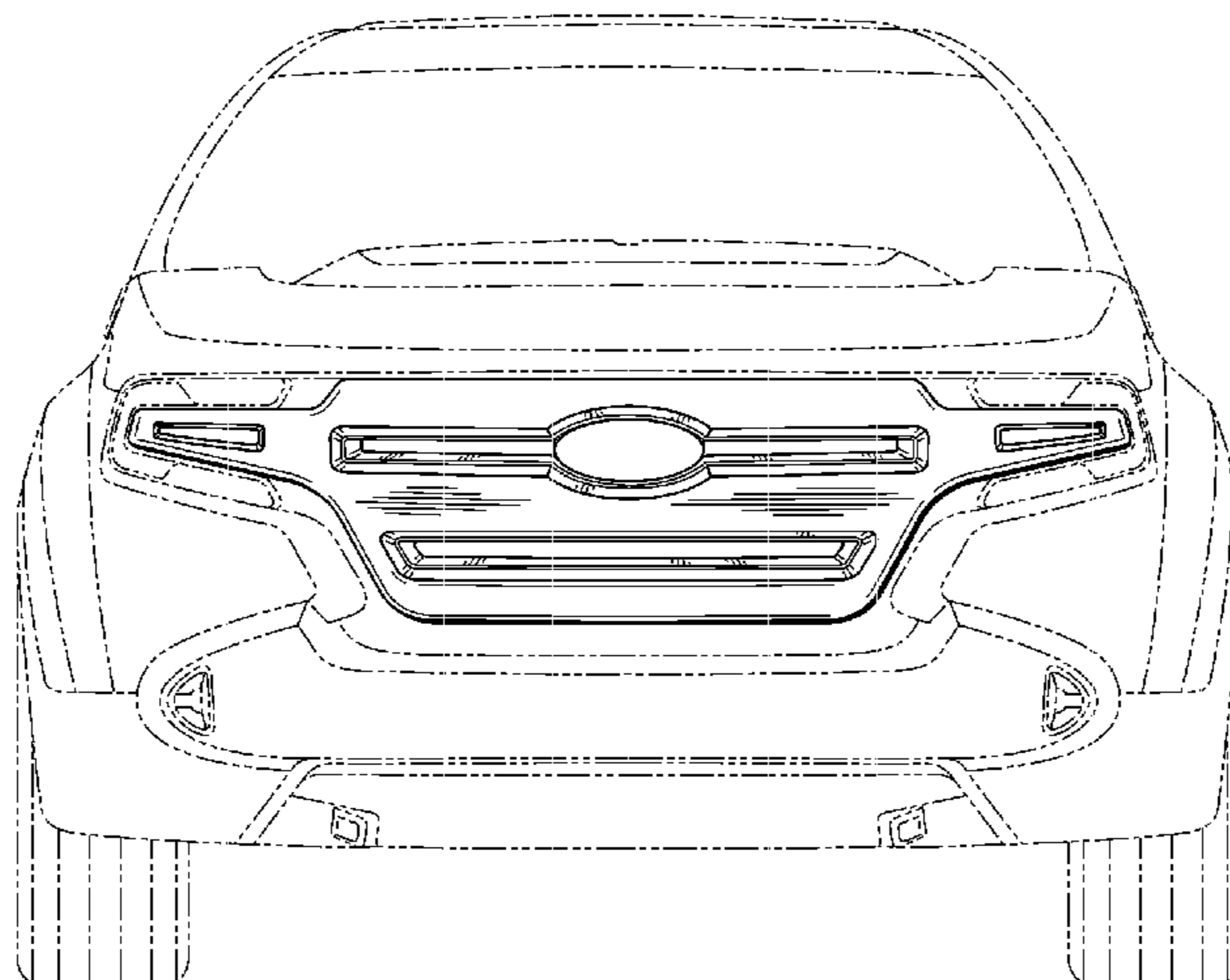

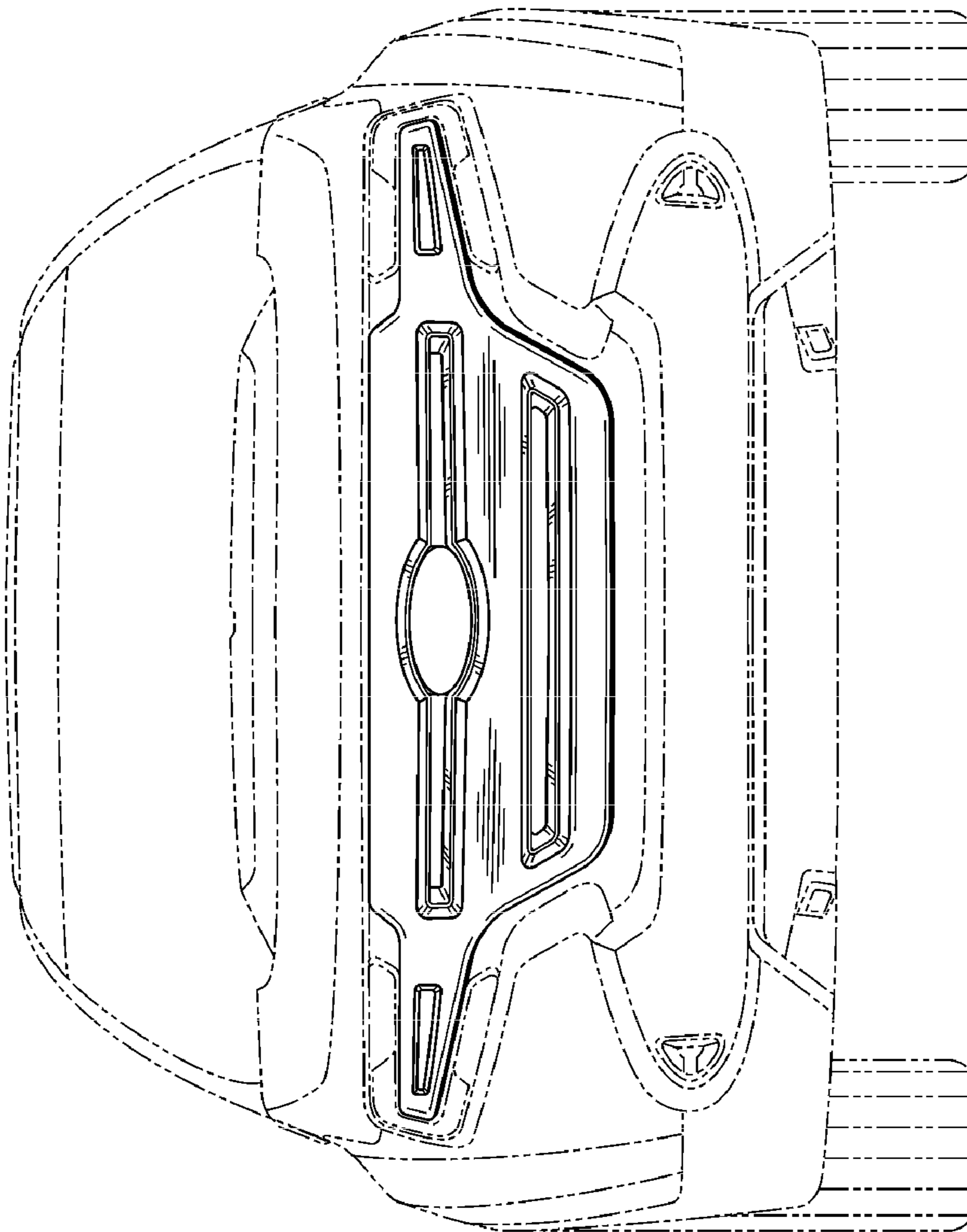

Fig. 1

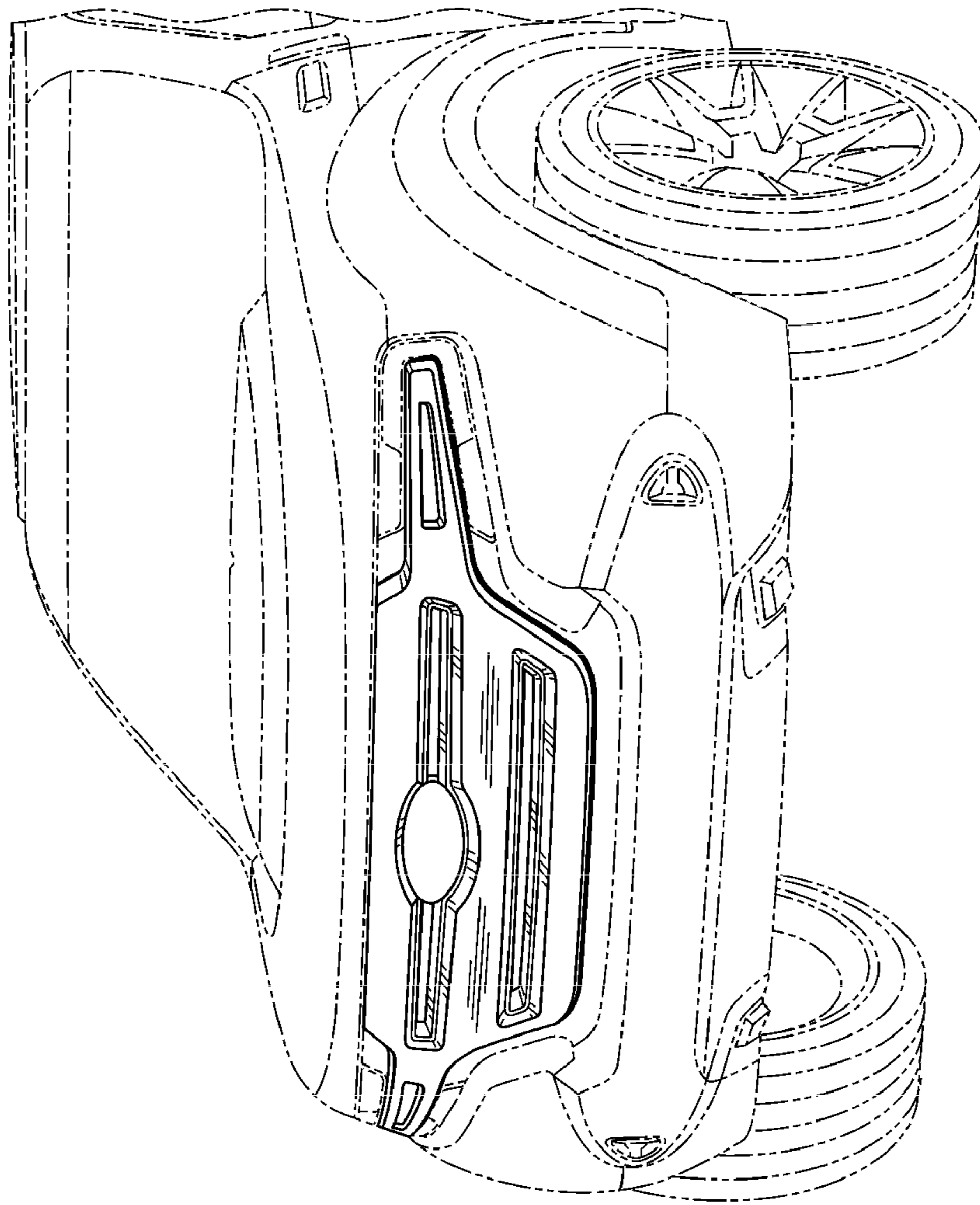

Fig. 2

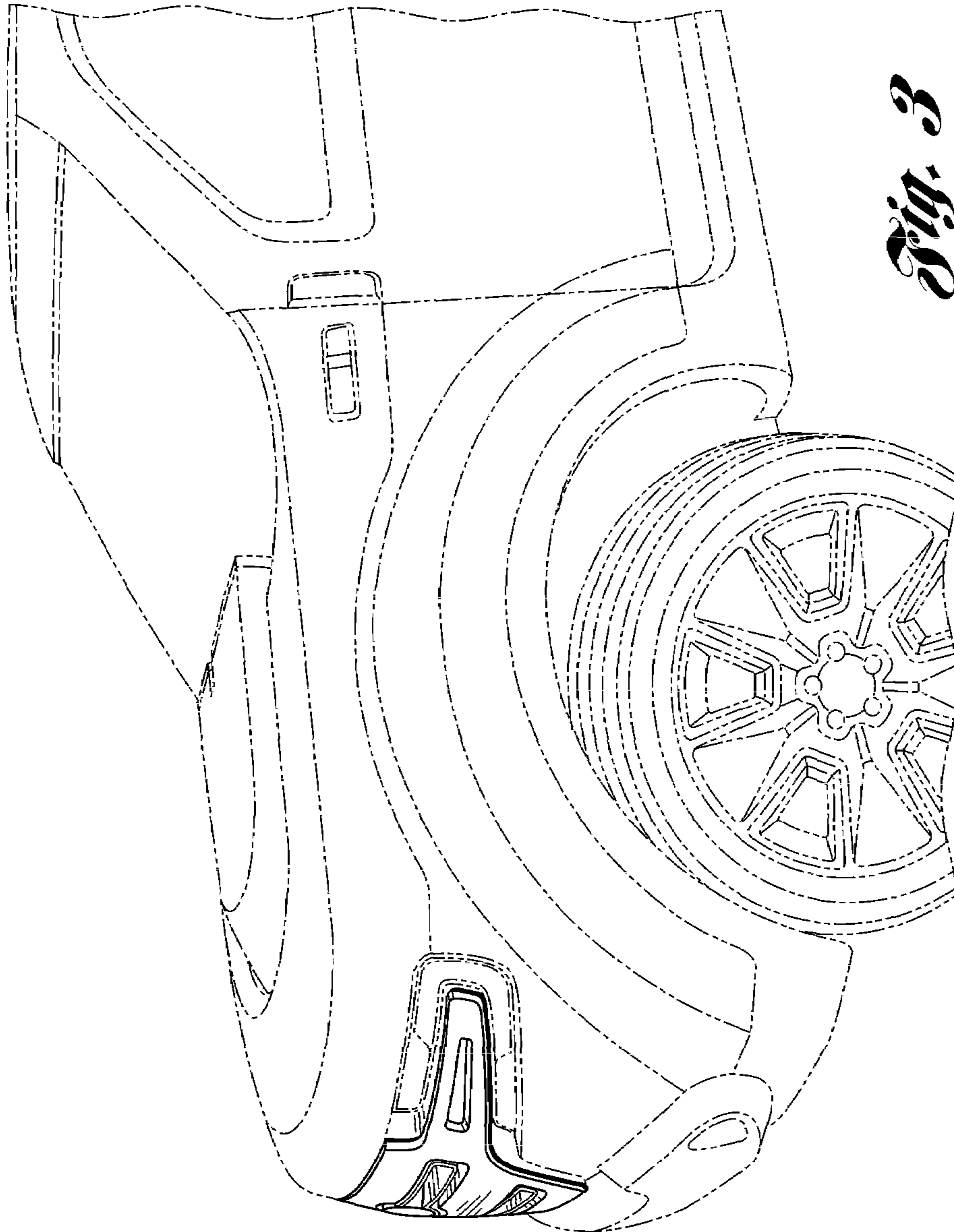

Fig. 3