



US00D594810S

(12) **United States Design Patent**
Cazals

(10) **Patent No.:** **US D594,810 S**
(45) **Date of Patent:** **** Jun. 23, 2009**

- (54) **AIRCRAFT TAIL**
- (75) Inventor: **Olivier Cazals**, Daux (FR)
- (73) Assignee: **Airbus France SAS**, Toulouse Cedex (FR)
- (**) Term: **14 Years**
- (21) Appl. No.: **29/306,067**
- (22) Filed: **Apr. 1, 2008**
- (51) **LOC (9) Cl.** **12-07**
- (52) **U.S. Cl.** **D12/345**
- (58) **Field of Classification Search** D12/319, D12/326-329, 333, 337, 340-345; D21/447-448, D21/450; 244/4 R, 5, 6, 7 R, 7 A, 7 B, 7 C, 244/21, 117 R, 119, 123.1, 129.1, 130
See application file for complete search history.

(56) **References Cited**

U.S. PATENT DOCUMENTS

D292,203 S *	10/1987	Ligeti	D12/319
5,381,985 A *	1/1995	Wechsler et al.	244/7 C
6,244,537 B1 *	6/2001	Rutherford	244/7 A
6,474,604 B1 *	11/2002	Carlow	244/198
D581,342 S *	11/2008	Cazals	D12/345
D581,343 S *	11/2008	Cazals	D12/345

OTHER PUBLICATIONS

- U.S. Appl. No. 29/305,899; Title: Elements of an Aircraft Tail, filed Mar. 29, 2008.
- U.S. Appl. No. 29/306,053; Title: Elements of an Aircraft Tail, filed Apr. 1, 2008.
- U.S. Appl. No. 29/306,060; Title: Element of an Aircraft, filed Apr. 1, 2008.
- U.S. Appl. No. 29/306,062; Title: Element of an Aircraft Body, filed Apr. 1, 2008.
- U.S. Appl. No. 29/306,066; Title: Elements of an Aircraft Tail, filed Apr. 1, 2008.
- U.S. Appl. No. 29/306,068; Title: Elements of an Aircraft Tail, filed Apr. 1, 2008.
- U.S. Appl. No. 29/306,078; Title: Elements of an Aircraft Tail, filed Apr. 1, 2008.
- U.S. Appl. No. 29/306,079; Title: Elements of an Aircraft Tail, filed Apr. 1, 2008.
- U.S. Appl. No. 29/306,412; Title: Elements of an Aircraft Tail, filed Apr. 9, 2008.

- U.S. Appl. No. 29/306,405; Title: Elements of an Aircraft Tail, filed Apr. 9, 2008.
- U.S. Appl. No. 29/306,406; Title: Elements of an Aircraft Tail, filed Apr. 9, 2008.
- U.S. Appl. No. 29/306,407; Title: Elements of an Aircraft Tail, filed Apr. 9, 2008.
- U.S. Appl. No. 29/306,408; Title: Elements of an Aircraft Tail, filed Apr. 9, 2008.
- U.S. Appl. No. 29/306,409; Title: Elements of an Aircraft Tail, filed Apr. 9, 2008.
- U.S. Appl. No. 29/306,410; Title: Elements of an Aircraft Tail, filed Apr. 9, 2008.

* cited by examiner

Primary Examiner—Ian Simmons
Assistant Examiner—Dana L Sipos
(74) *Attorney, Agent, or Firm*—Osler, Hoskin & Harcourt LLP

(57) **CLAIM**

I claim the ornamental design of an aircraft tail, as shown and described.

DESCRIPTION

FIG. 1 is a partial top, front, right side perspective view of an aircraft tail according to my new design

FIG. 2 is a partial top, rear, left side perspective view thereof;

FIG. 3 is a top, front, right side perspective view of the aircraft tail of FIG. 1;

FIG. 4 is a rear elevation view thereof;

FIG. 5 is a top plan view thereof;

FIG. 6 is a bottom plan view thereof;

FIG. 7 is a left side elevation view thereof, the right side elevation view being a mirror image; and,

FIG. 8 is a top, front, right side perspective view thereof, showing unclaimed engines in place.

Throughout the Figures, broken lines showing environment or structure are for illustrative purposes only and form no part of the claimed design.

1 Claim, 8 Drawing Sheets

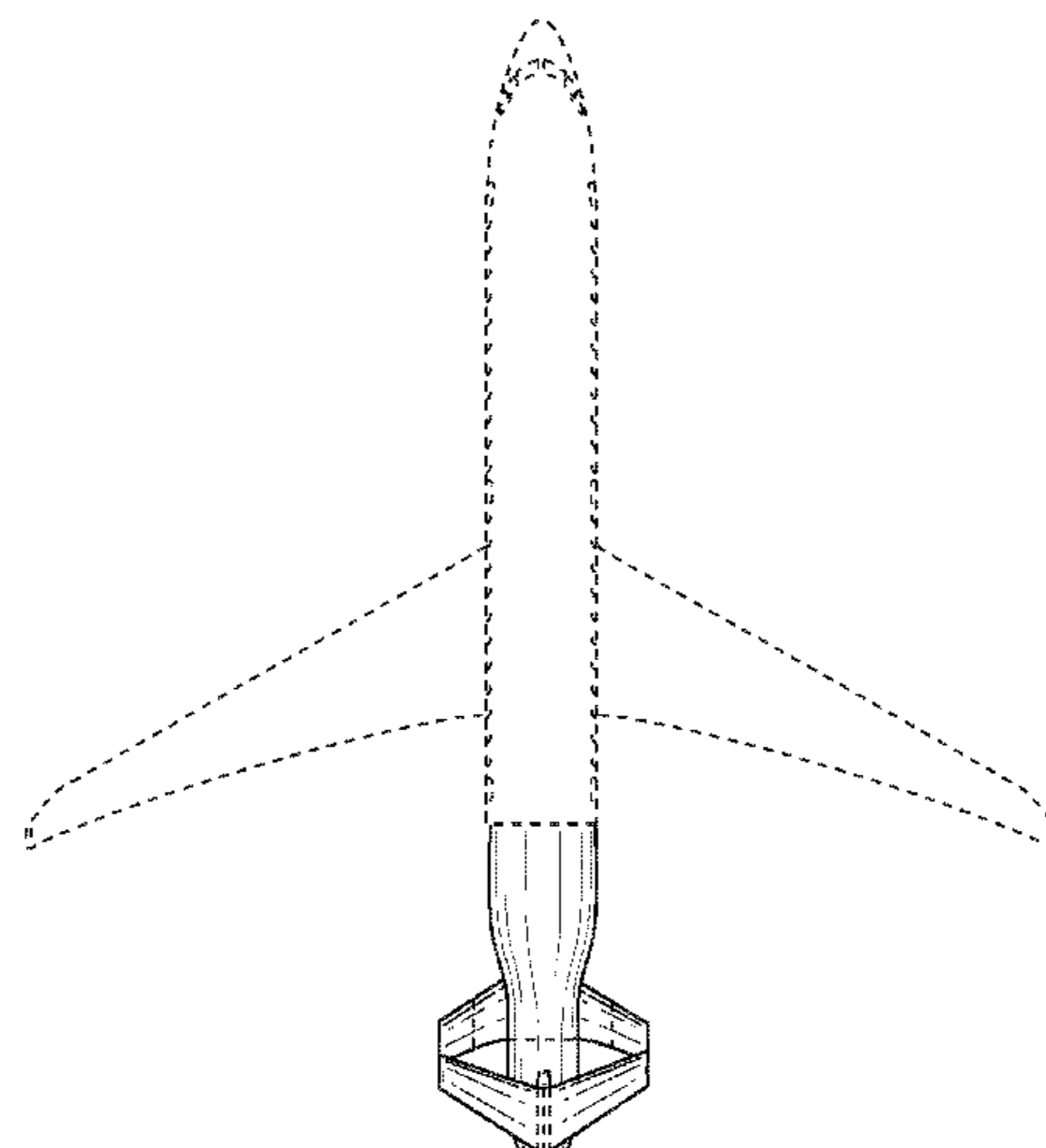
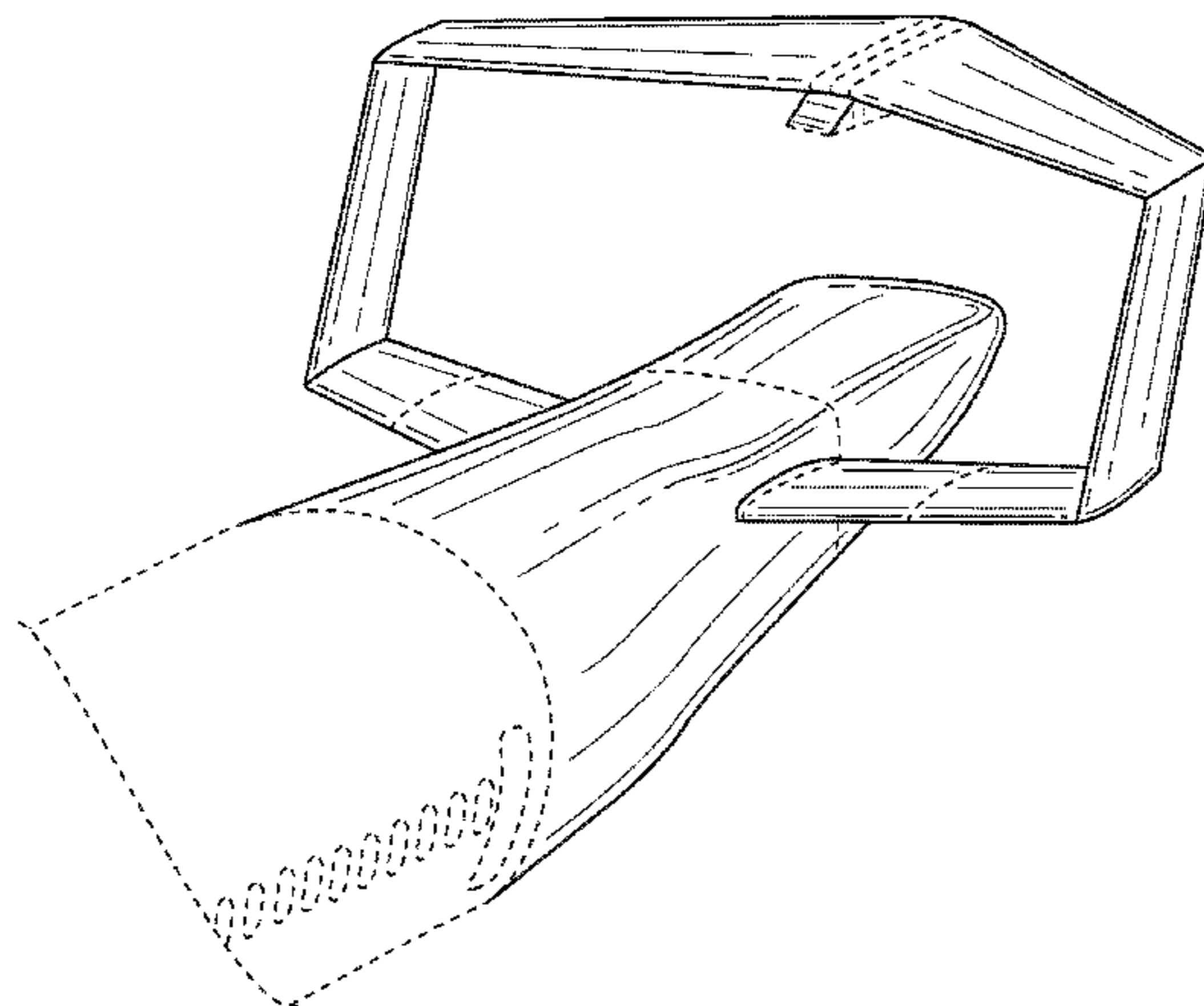

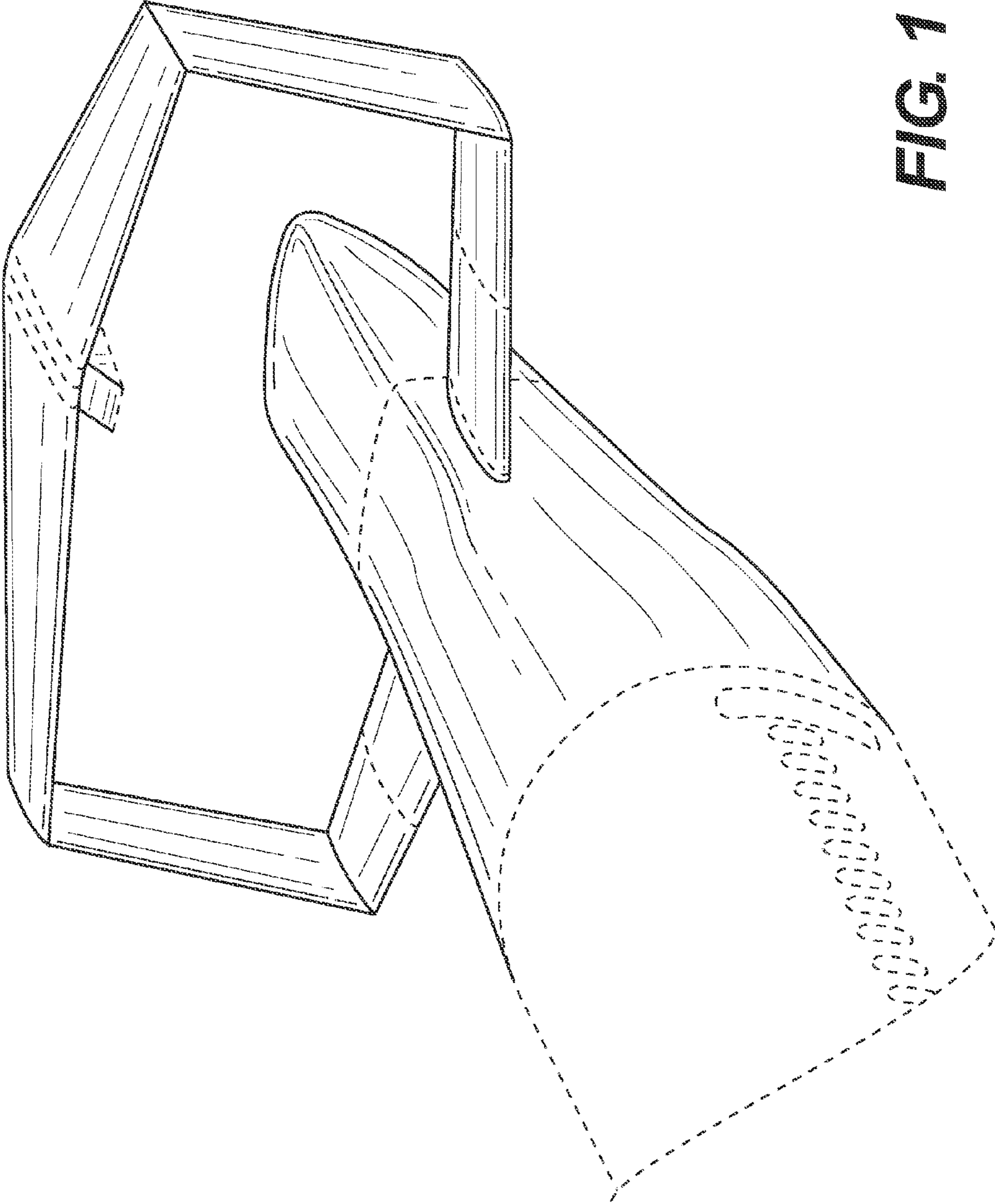

FIG. 1

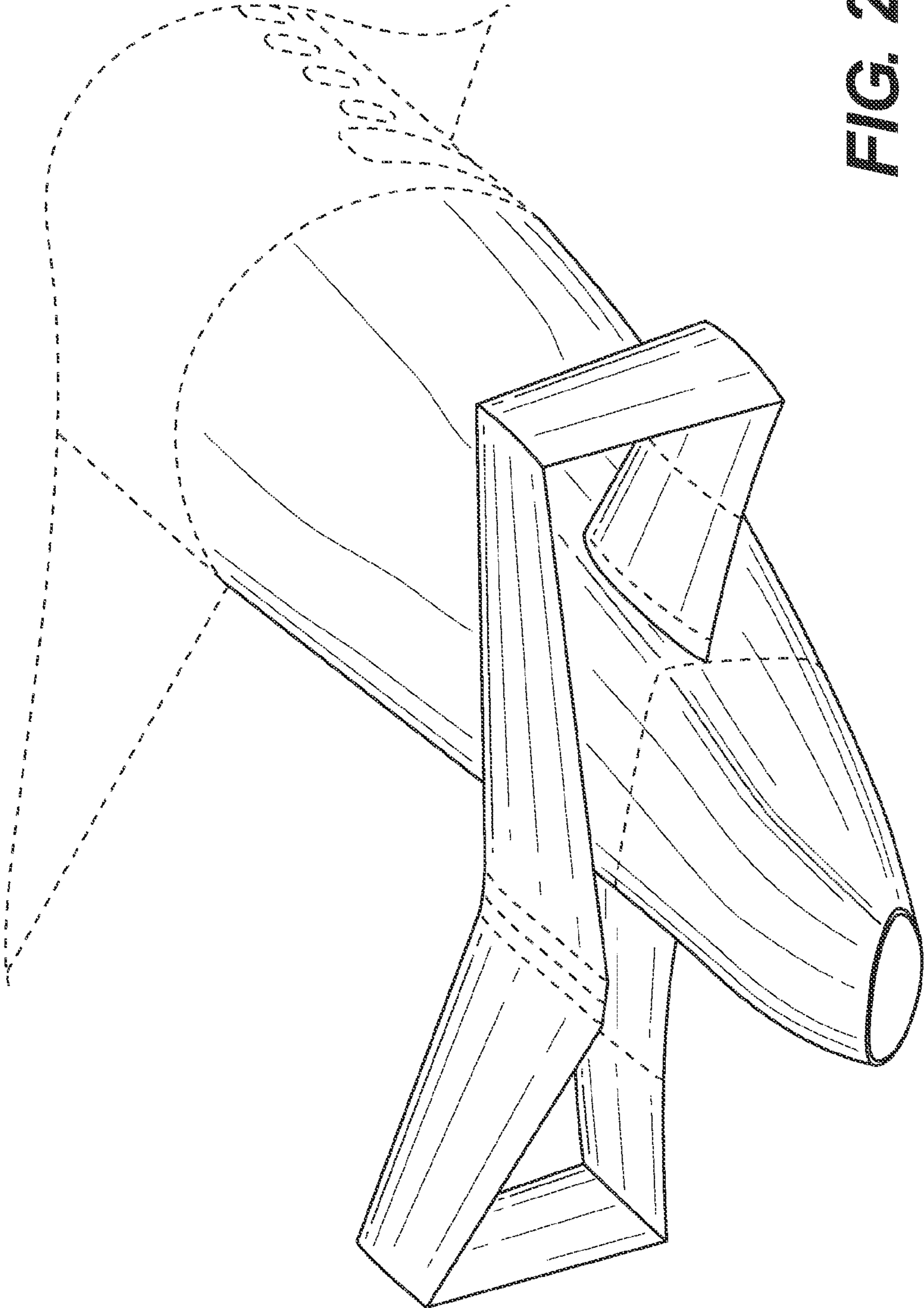

FIG. 2

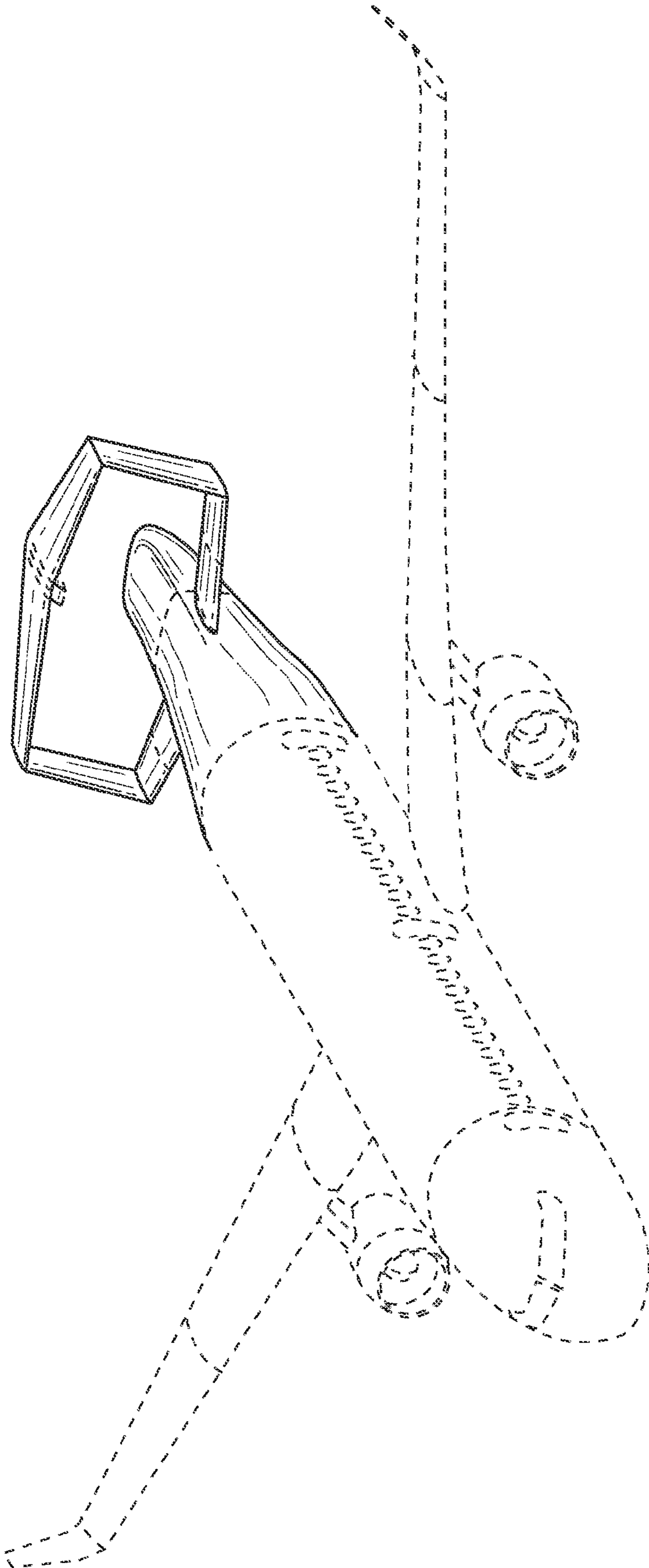

FIG. 3

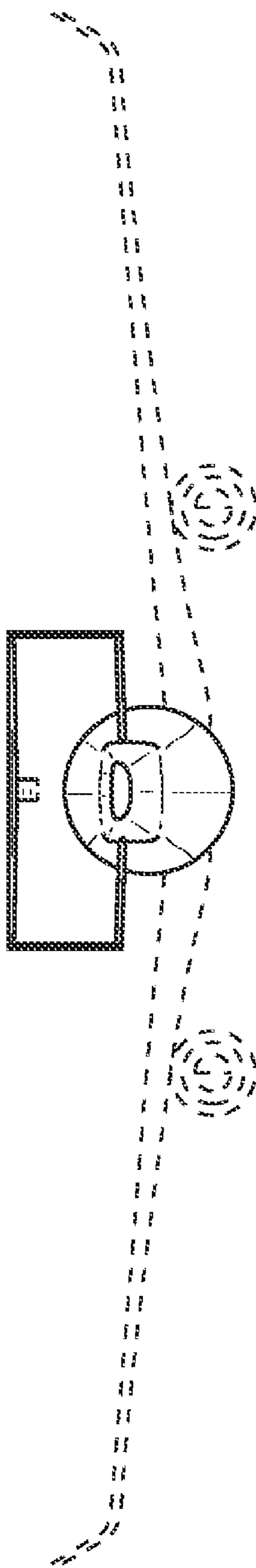

FIG. 4

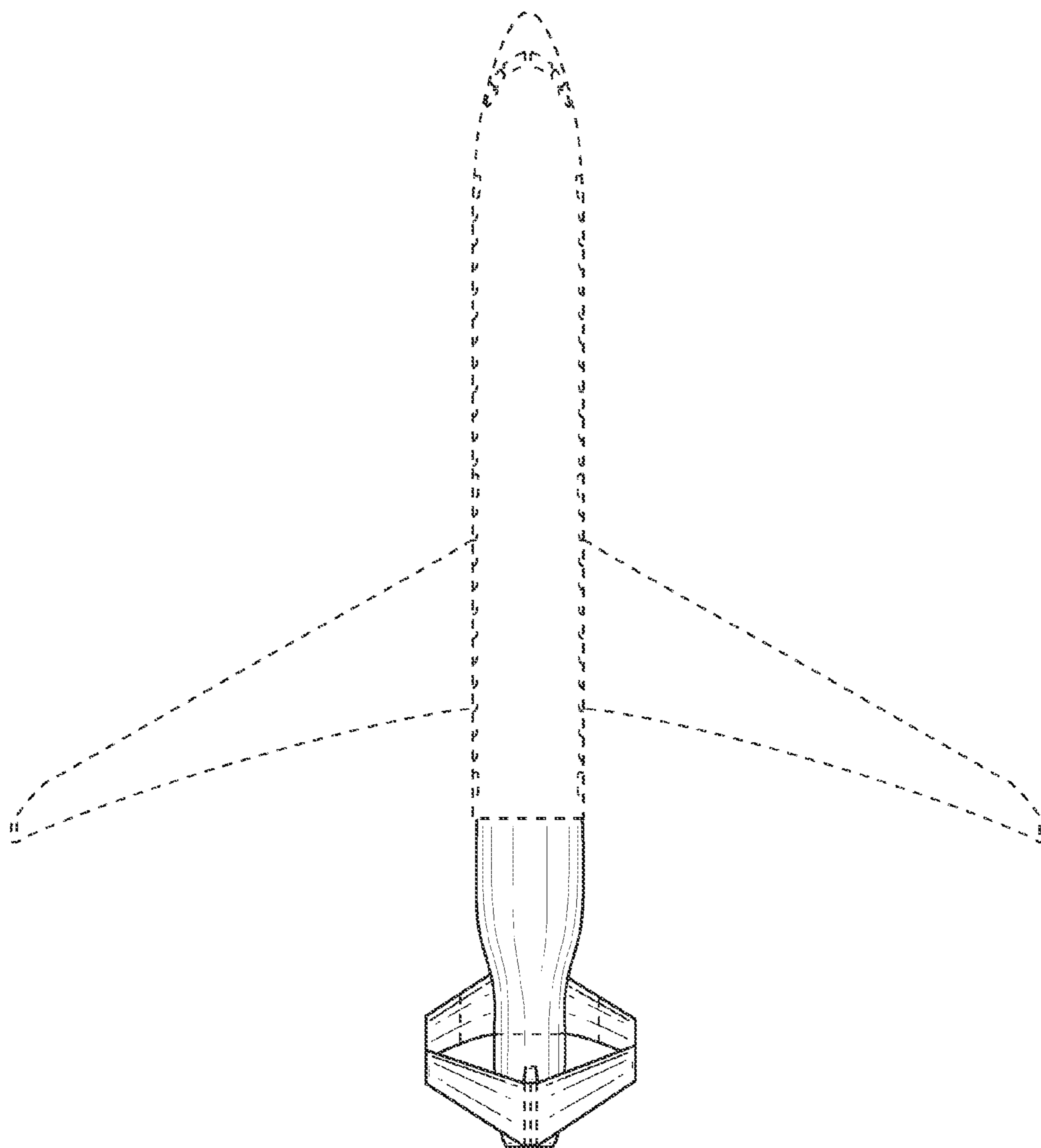

FIG. 5

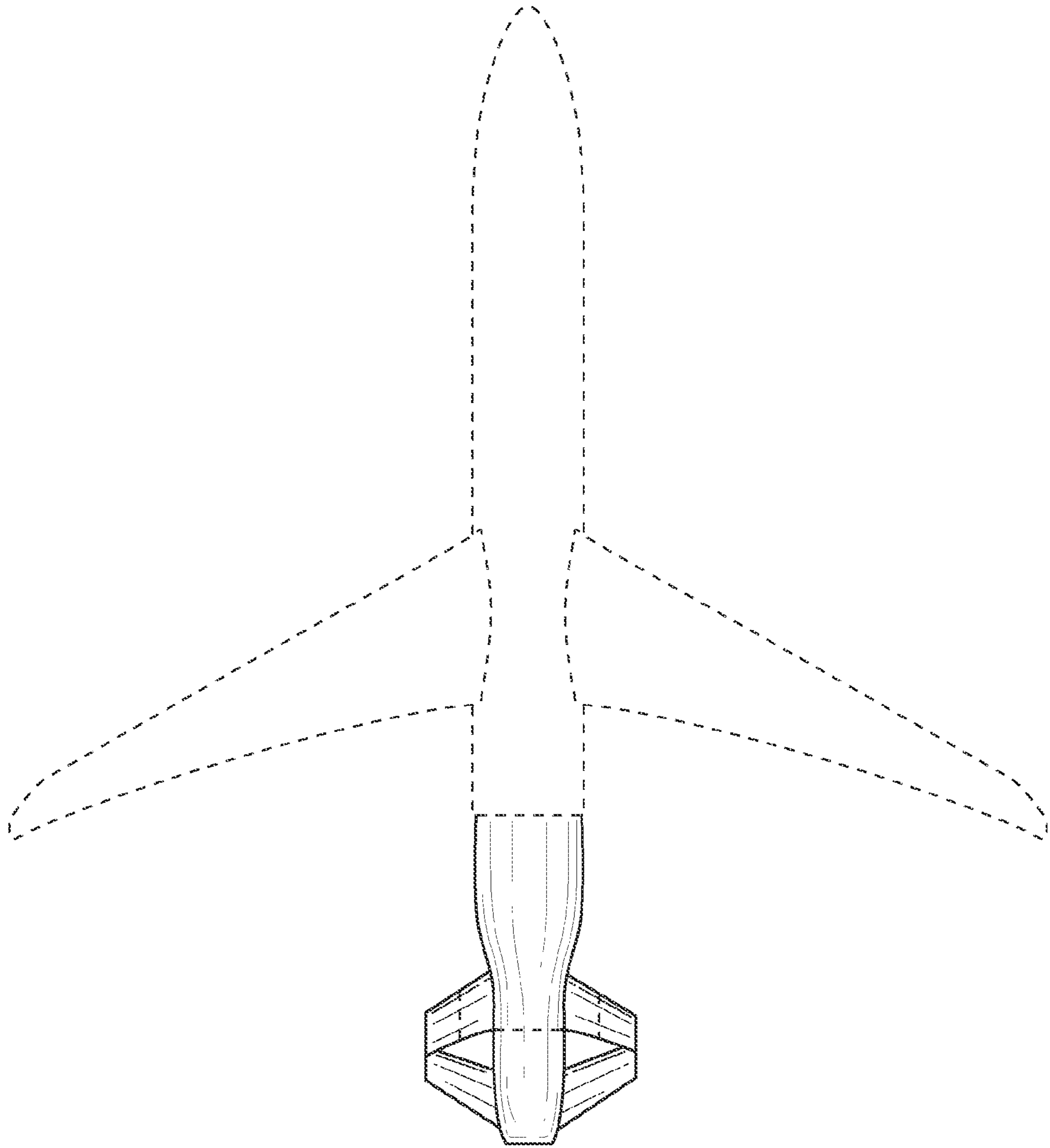

FIG. 6

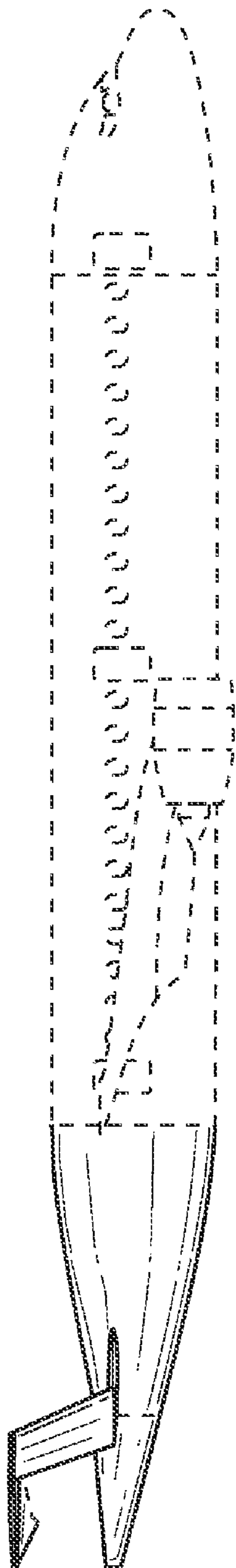

FIG. 7

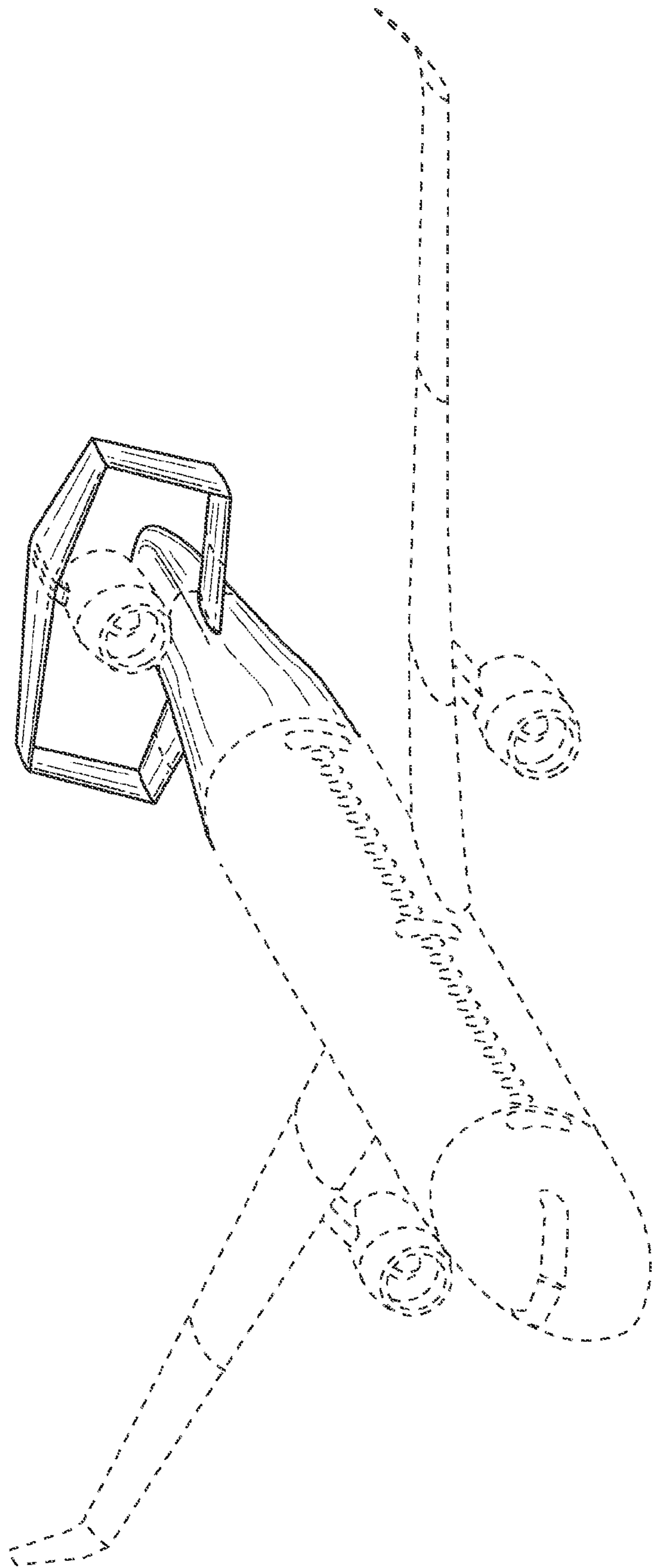

FIG. 8