



US00D594784S

(12) **United States Design Patent**
Ichihara et al.

(10) **Patent No.:** **US D594,784 S**
(45) **Date of Patent:** **** Jun. 23, 2009**

(54) **MOTORCYCLE**

(75) Inventors: **Fumio Ichihara**, Hyogo (JP); **Shunji Tanaka**, Kobe (JP)

(73) Assignee: **Kawasaki Jukogyo Kabushiki Kaisha**, Hyogo (JP)

(**) Term: **14 Years**

(21) Appl. No.: **29/273,807**

(22) Filed: **Mar. 13, 2007**

(30) **Foreign Application Priority Data**

Sep. 20, 2006 (JP) 2006-025072

(51) **LOC (9) Cl.** **12-11**

(52) **U.S. Cl.** **D12/110**

(58) **Field of Classification Search** D12/110;
180/219, 220, 225, 229

See application file for complete search history.

(56) **References Cited**

U.S. PATENT DOCUMENTS

D269,170 S * 5/1983 Aoyama et al. D12/110
4,691,800 A * 9/1987 Kadono et al. 180/219
D312,807 S * 12/1990 Kohama et al. D12/110
D325,361 S * 4/1992 Gevert D12/110
D384,601 S * 10/1997 Hiruma et al. D12/110

D385,226 S * 10/1997 Mogi et al. D12/110
D387,017 S * 12/1997 Wakita et al. D12/110
D419,922 S * 2/2000 Yamase et al. D12/110
D513,481 S * 1/2006 Lin D12/110

* cited by examiner

Primary Examiner—Cathron C Brooks
Assistant Examiner—Linda Brooks

(57) **CLAIM**

The ornamental design for a motorcycle, as shown and described.

DESCRIPTION

FIG. 1 is a front elevational view of a motorcycle showing our new design;

FIG. 2 is a rear elevational view thereof;

FIG. 3 is a left side elevational view thereof;

FIG. 4 is a right side elevational view thereof;

FIG. 5 is a top plan view thereof;

FIG. 6 is a bottom plan view thereof;

FIG. 7 is a front perspective view thereof; and,

FIG. 8 is a rear perspective view thereof.

The portion shown in broken lines form no part of the claimed design.

1 Claim, 8 Drawing Sheets

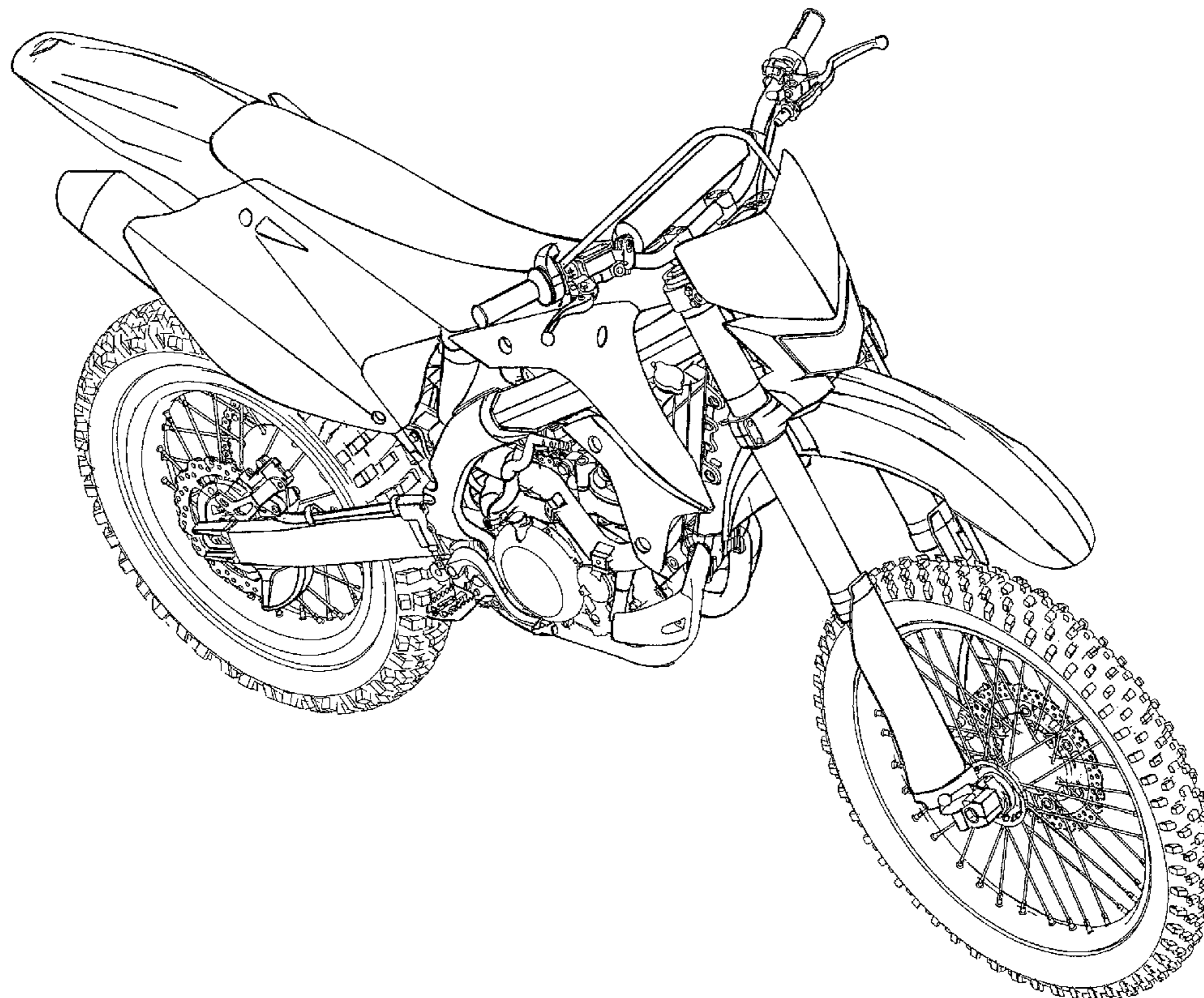

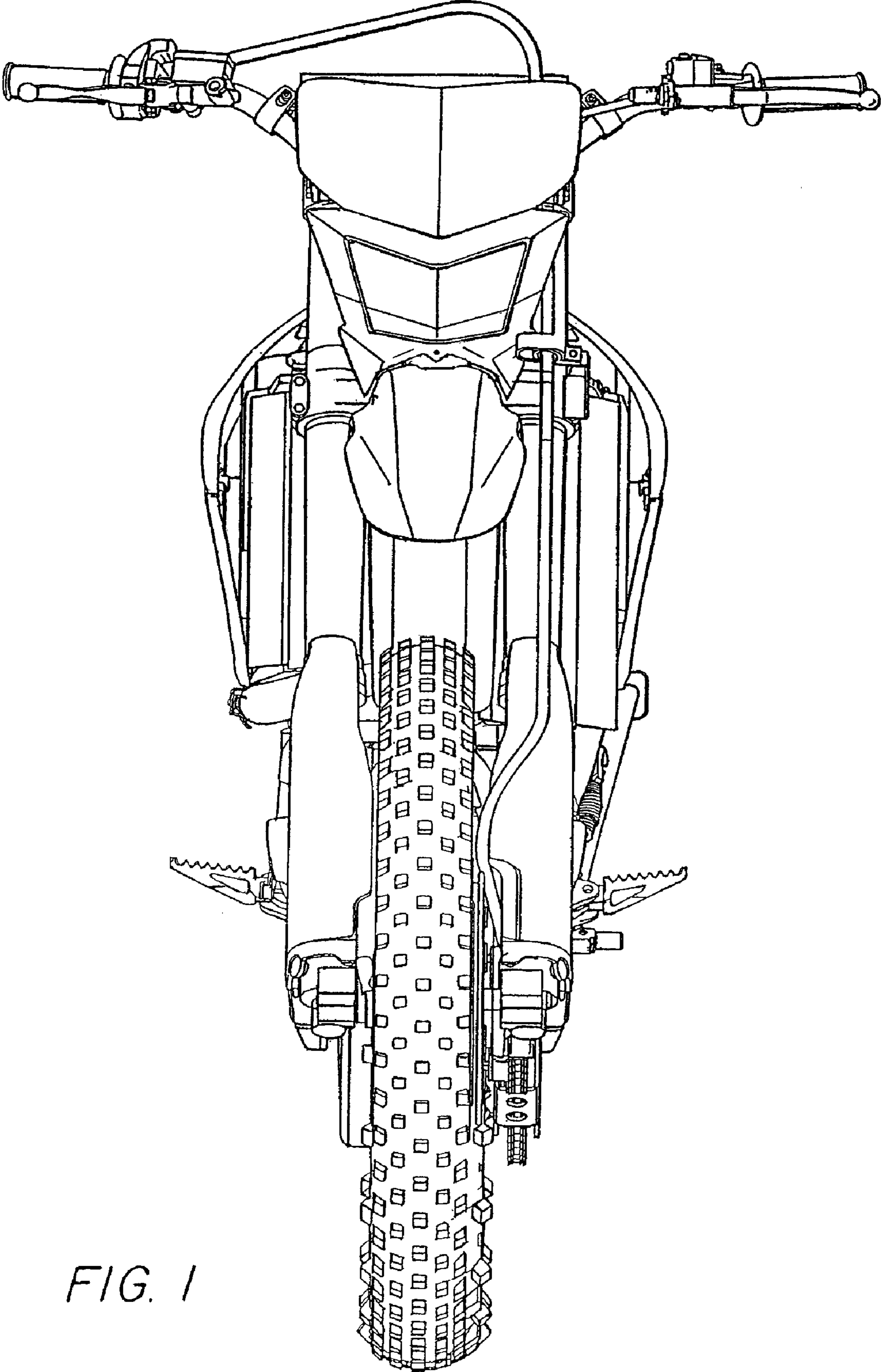

FIG. 1

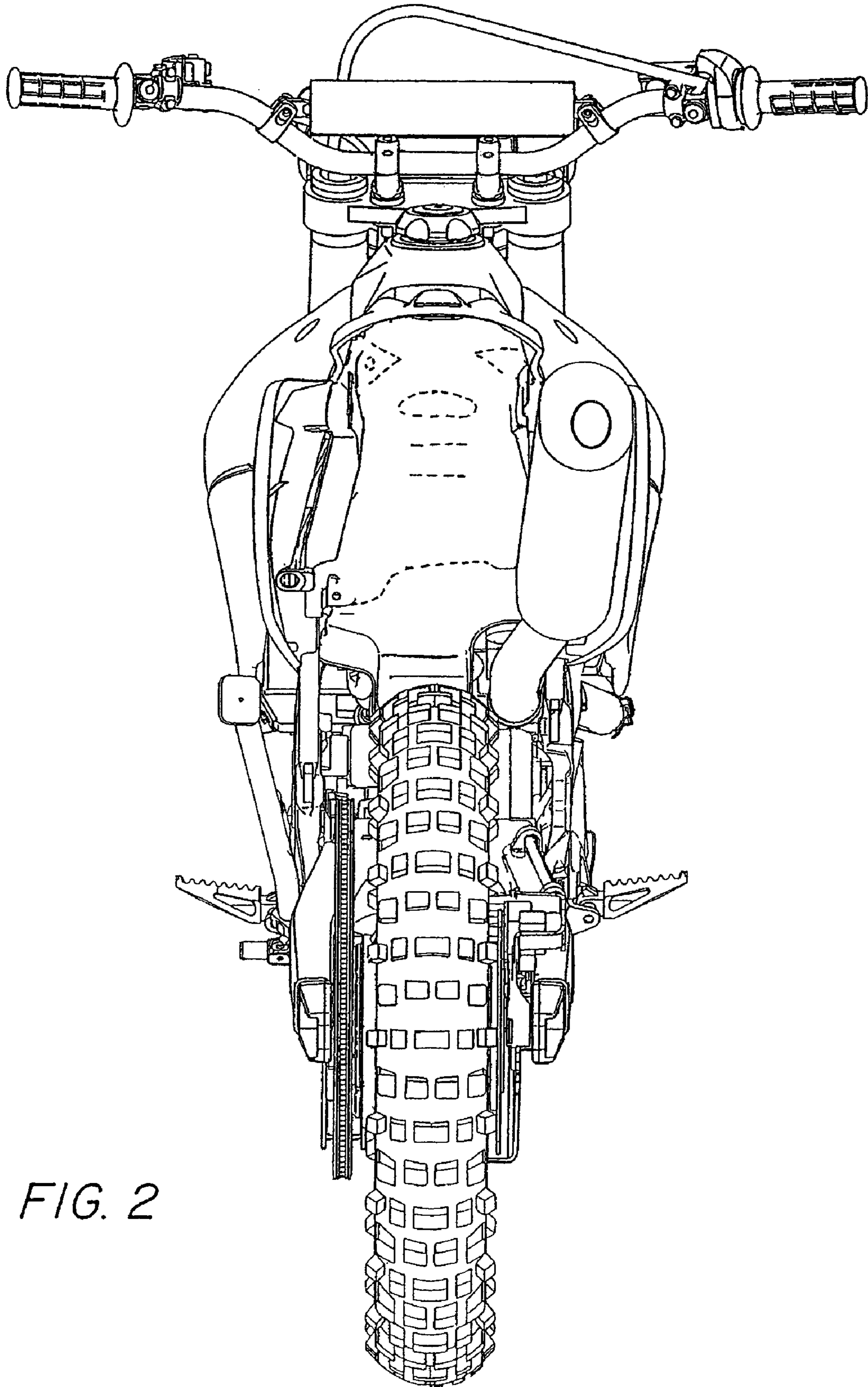

FIG. 2

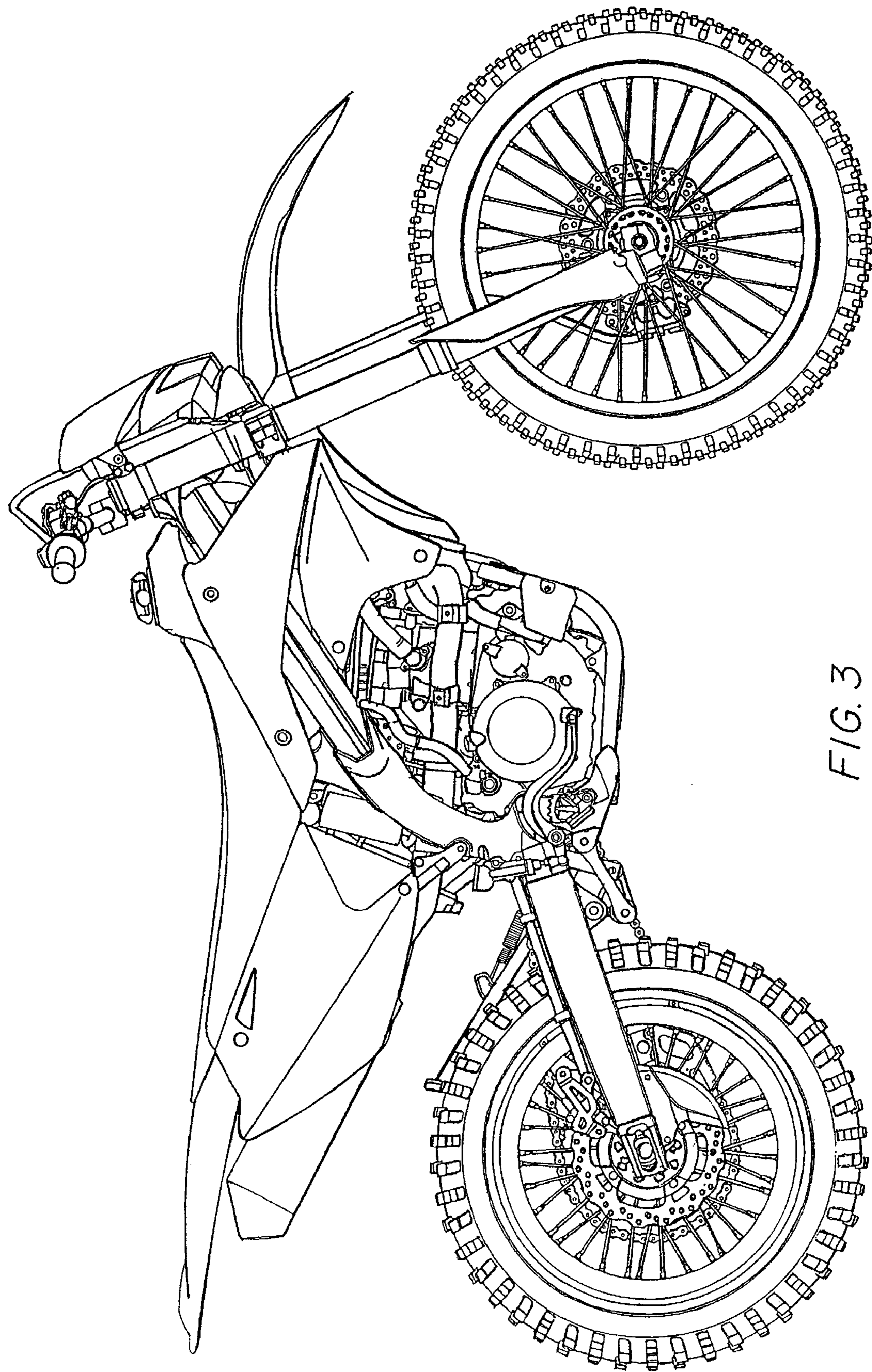

FIG. 3

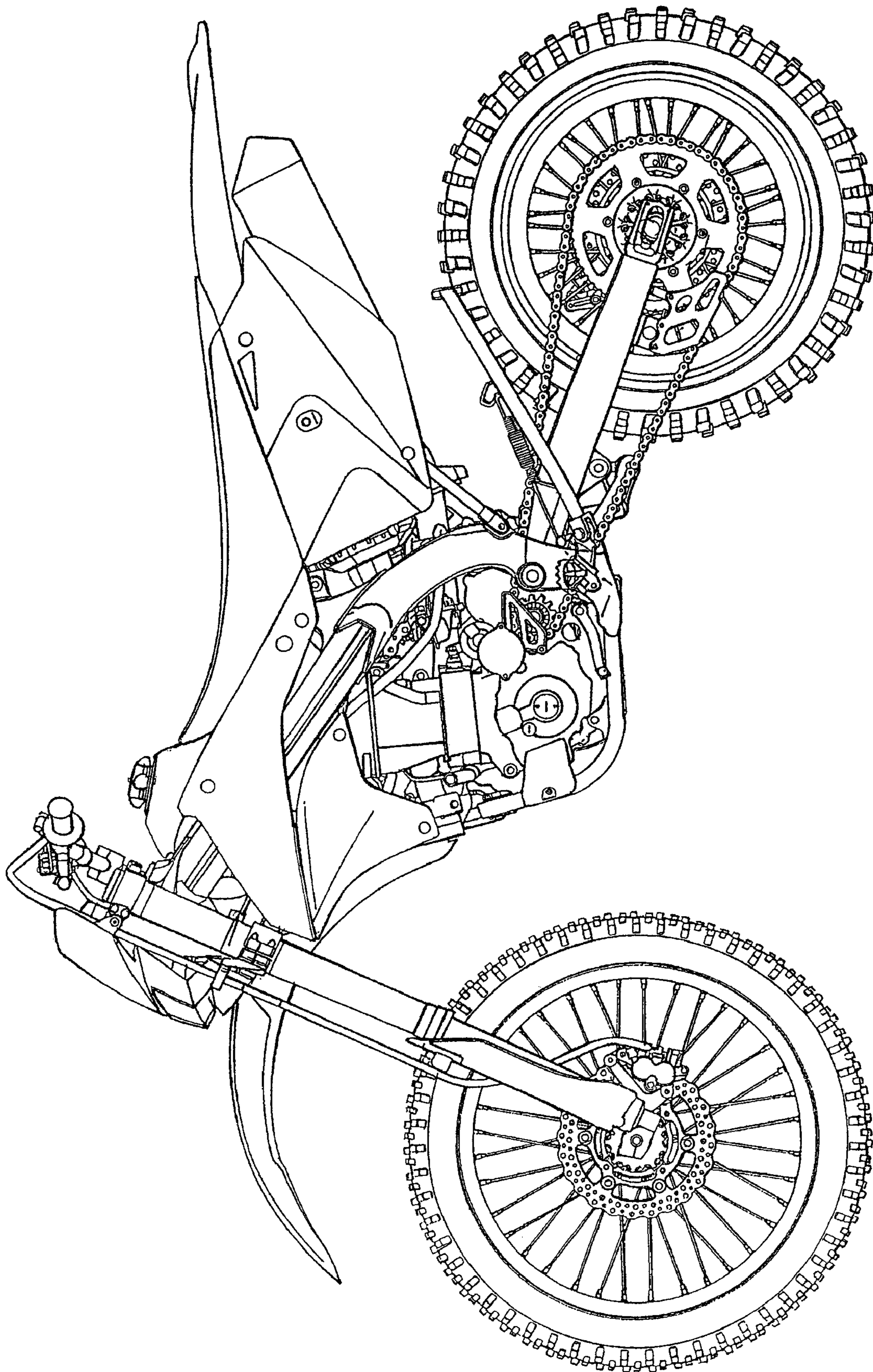

FIG. 4

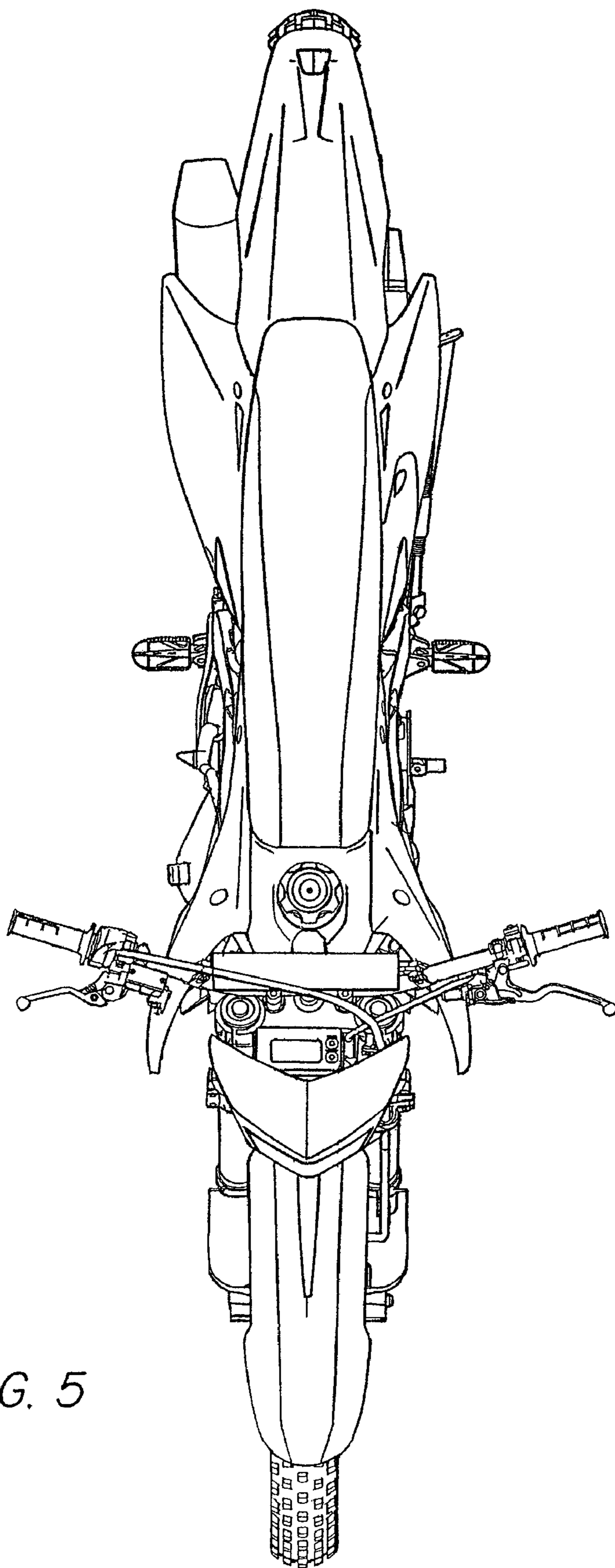

FIG. 5

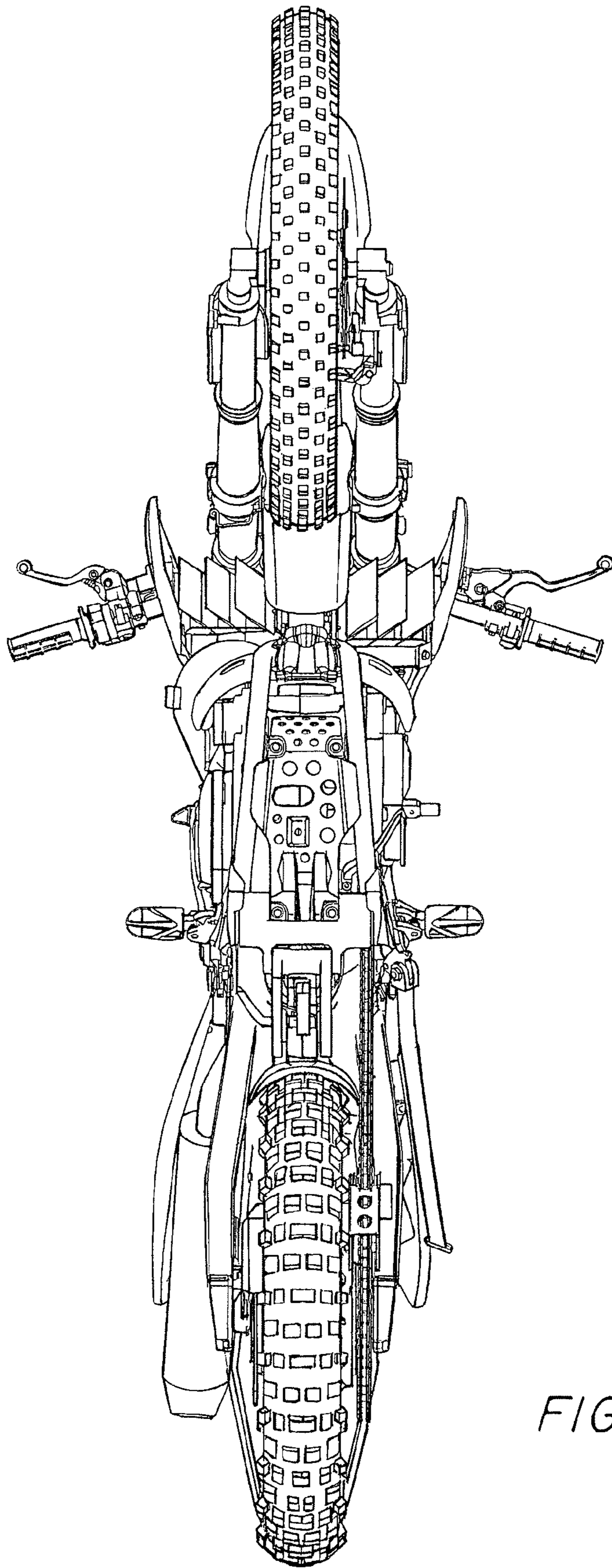

FIG. 6

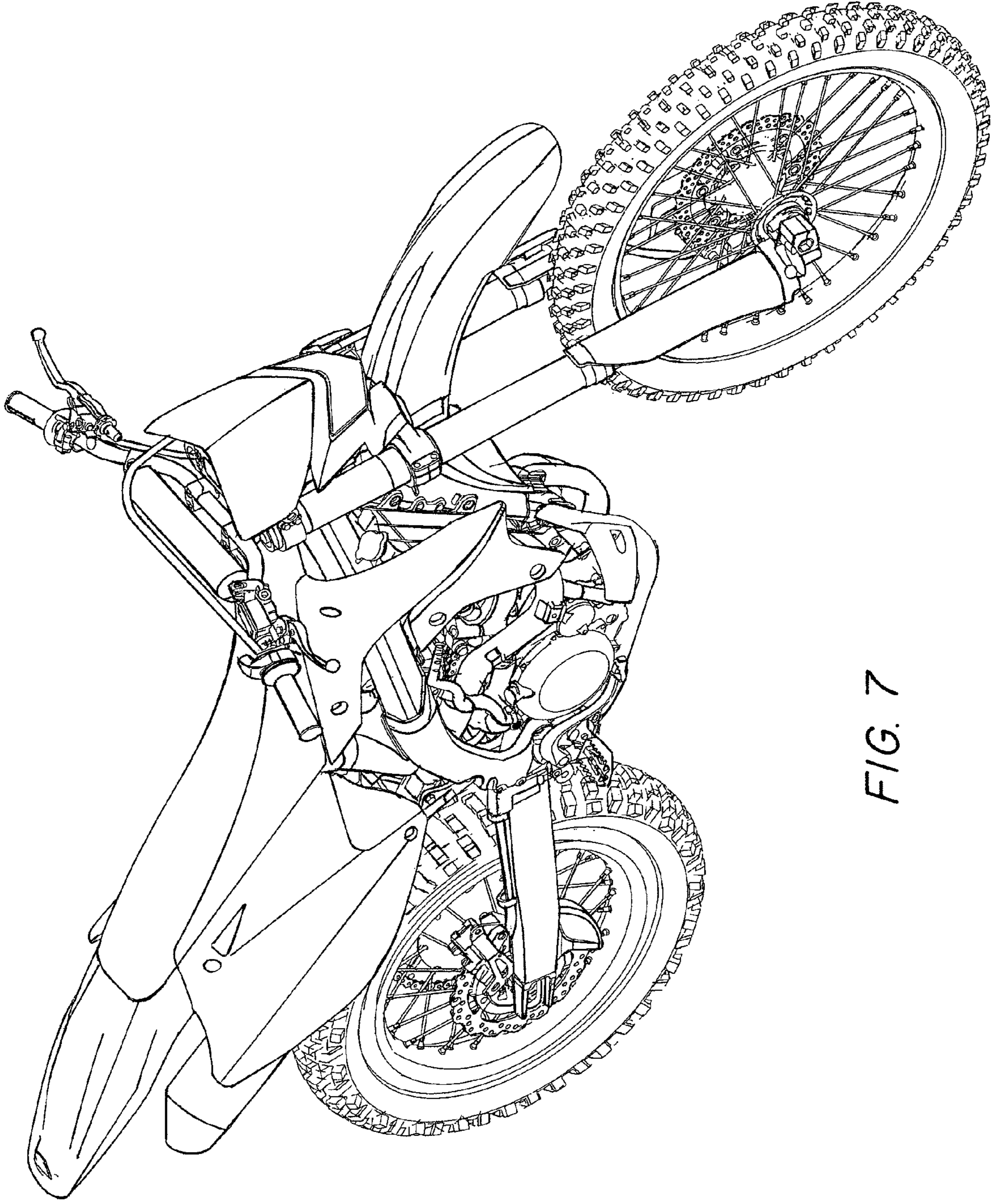

FIG. 7

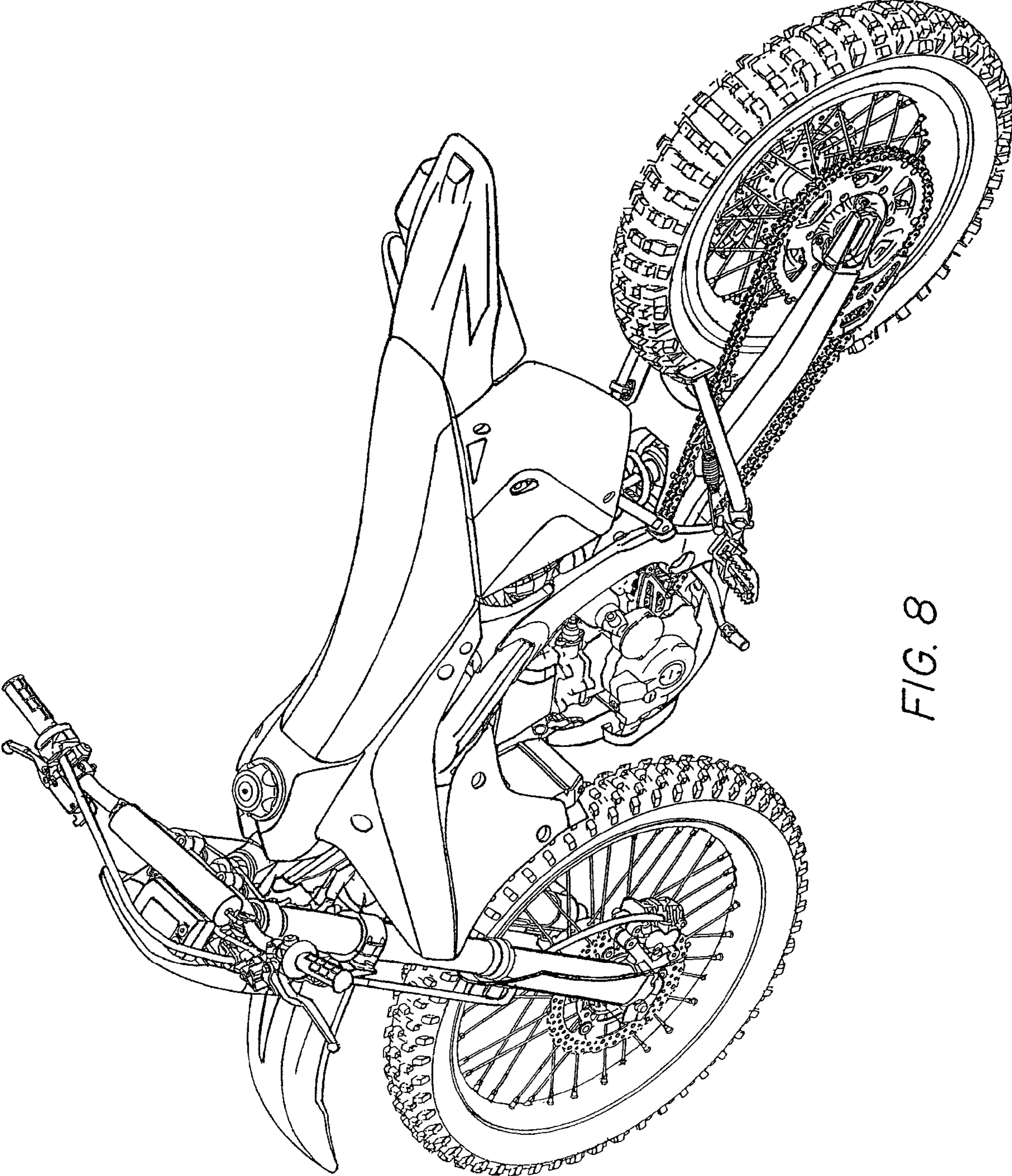

FIG. 8