



US00D594779S

(12) **United States Design Patent**
Longpre et al.

(10) **Patent No.:** **US D594,779 S**
(45) **Date of Patent:** **** Jun. 23, 2009**

(54) **SNOWMOBILE BODY PANEL**

(57) **CLAIM**

(75) Inventors: **Guillaume Longpre**, Granby (CA);
Martin Portelance, Chicoutimi (CA);
Etienne Guay, Orford (CA)

The ornamental design for a snowmobile body panel, as shown and described.

(73) Assignee: **Bombardier Recreational Products Inc.**, Valcourt (CA)

DESCRIPTION

(**) Term: **14 Years**

FIG. 1 is a rear right perspective view showing a first embodiment of a snowmobile body panel according to our design;

(21) Appl. No.: **29/299,930**

FIG. 2 is a left side elevation view thereof;

(22) Filed: **Jan. 7, 2008**

FIG. 3 is a right side elevation view thereof;

(51) **LOC (9) Cl.** **12-14**

FIG. 4 is a front elevation view thereof;

(52) **U.S. Cl.** **D12/7**

FIG. 5 is a rear elevation view thereof;

(58) **Field of Classification Search** D12/7,
D12/110, 111, 9, 112, 307, 400, 86, 85, 88;
D21/533; 180/182, 190, 184-186, 9.25,
180/180, 219, 193, 194; 280/845; D6/354
See application file for complete search history.

FIG. 6 is a top plan view thereof;

FIG. 7 is a bottom plan view thereof;

FIG. 8 is a rear left perspective view showing a second embodiment of a snowmobile body panel according to our design;

(56) **References Cited**

FIG. 9 is a right side elevation view thereof;

U.S. PATENT DOCUMENTS

FIG. 10 is a left side elevation view thereof;

D253,883 S 1/1980 Shimasaki

FIG. 11 is a front elevation view thereof;

D264,830 S 6/1982 Ishiyama

FIG. 12 is a rear elevation view thereof;

D273,185 S 3/1984 Ishiyama

FIG. 13 is a top plan view thereof; and,

(Continued)

FIG. 14 is a bottom plan view thereof.

OTHER PUBLICATIONS

Throughout the Figures, the dashed broken lines represent environmental matter and/or unclaimed portions of the snowmobile front fairing and form no part of the claimed design. The dash-dot broken lines represent the boundary between claimed and unclaimed areas and form no part of the claimed design.

U.S. Appl. No. 29/299,911, filed Jan. 7, 2008. Title: Snowmobile.

(Continued)

In the drawings, the broken lines depict unclaimed subject matter only and form no part of the claimed design. The dash-dot lines represent the boundary between claimed and unclaimed areas and also form no part of the claimed design.

Primary Examiner—T. Chase Nelson

Assistant Examiner—Ania K Dworzecka

(74) *Attorney, Agent, or Firm*—Osler, Hoskin & Harcourt LLP

1 Claim, 12 Drawing Sheets

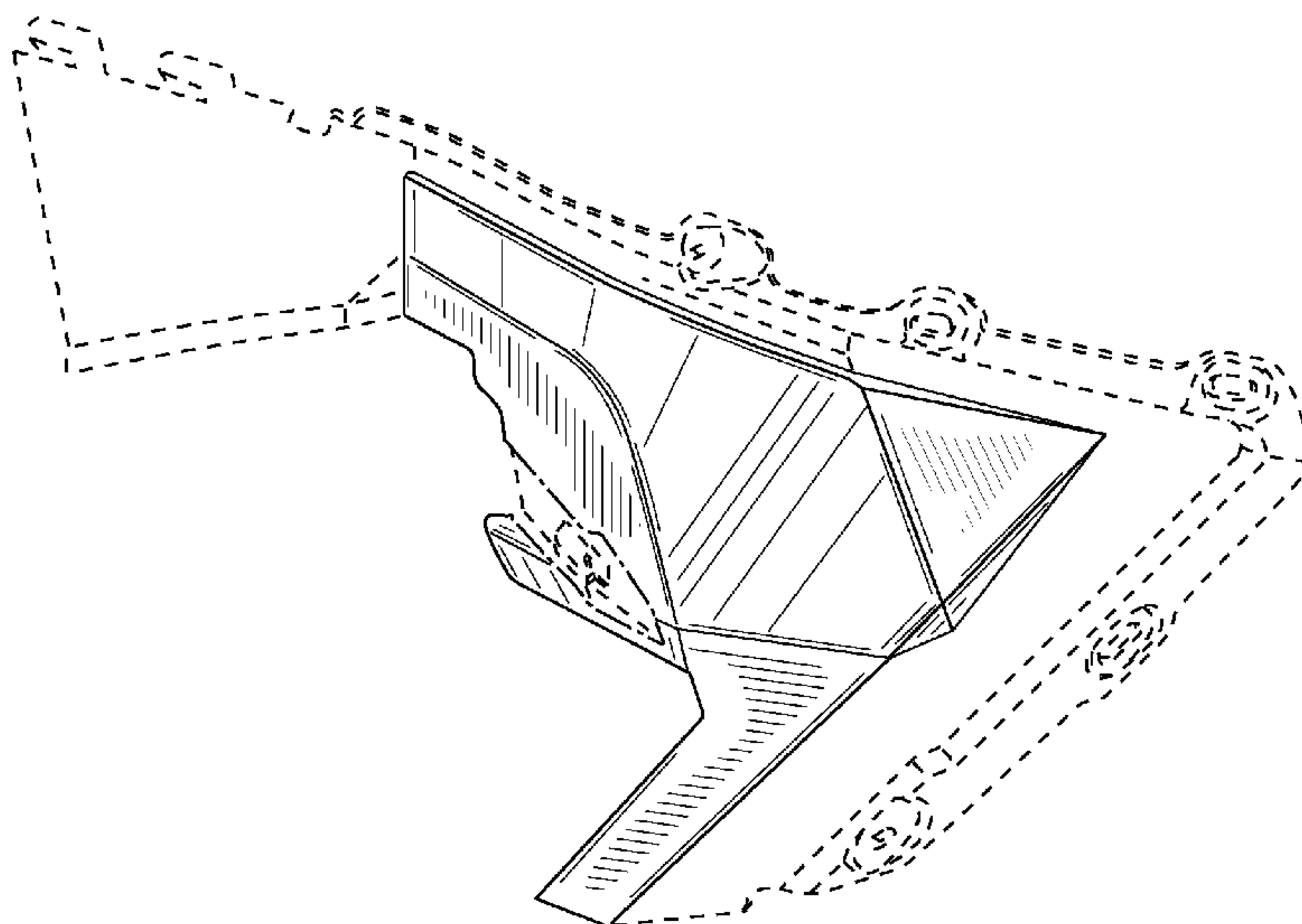

US D594,779 S

Page 2

U.S. PATENT DOCUMENTS

D278,892 S 5/1985 Kobayashi
D314,535 S 2/1991 Matsue
D319,607 S 9/1991 Anselme
D328,575 S 8/1992 Berto
D334,374 S 3/1993 Hornai
D342,044 S 12/1993 Hornai
D342,220 S 12/1993 Hornai
D346,137 S 4/1994 Hornai
D389,780 S * 1/1998 Komatsu et al. D12/7
D403,272 S 12/1998 Cadotte et al.
D403,273 S 12/1998 Cadotte et al.
D438,821 S 3/2001 Cadotte et al.
D446,166 S 8/2001 Cadotte et al.
D457,106 S 5/2002 Cadotte et al.
D457,202 S 5/2002 Baskin et al.
D466,049 S 11/2002 Cadotte
D468,547 S 1/2003 Cadotte et al.
D477,247 S 7/2003 Cadotte et al.
D477,248 S 7/2003 Cadotte et al.
D478,297 S 8/2003 Cadotte et al.
D478,532 S 8/2003 Crepeau et al.
D479,490 S 9/2003 Cadotte et al.
D479,696 S 9/2003 Cadotte et al.
D479,697 S 9/2003 Cadotte et al.
D479,813 S 9/2003 Cadotte et al.
D479,814 S 9/2003 Cadotte et al.
D479,815 S 9/2003 Crepeau et al.
D479,816 S 9/2003 Crepeau et al.
D480,019 S 9/2003 Cadotte et al.
D480,020 S 9/2003 Crepeau et al.
D487,233 S 3/2004 Cadotte et al.
D487,413 S 3/2004 Cadotte et al.
D488,094 S 4/2004 Cadotte et al.
D488,095 S 4/2004 Cadotte et al.
D488,096 S 4/2004 Cadotte et al.
D488,097 S 4/2004 Cadotte et al.
D488,098 S 4/2004 Cadotte et al.
D488,404 S 4/2004 Cadotte et al.
D493,121 S 7/2004 Sanschagrín et al.
D493,390 S 7/2004 Sanschagrín et al.

D494,100 S 8/2004 Sanschagrín et al.
D494,502 S 8/2004 Sanschagrín et al.
D494,503 S 8/2004 Sanschagrín et al.
D494,504 S 8/2004 Sanschagrín et al.
D494,505 S 8/2004 Sanschagrín et al.
D494,889 S 8/2004 Sanschagrín et al.
D495,274 S 8/2004 Sanschagrín et al.
D495,973 S 9/2004 Cadotte et al.
D496,883 S 10/2004 Sanschagrín et al.
D499,669 S 12/2004 Sanschagrín et al.
D505,889 S 6/2005 Girouard et al.
D511,998 S 11/2005 Deluy
D512,662 S 12/2005 Deluy
D515,457 S 2/2006 Deluy
D541,192 S 4/2007 Jokelainen
D548,136 S 8/2007 Musselman
D548,137 S 8/2007 Curthelet
D548,645 S 8/2007 Curthelet
D552,506 S 10/2007 Deluy
D563,271 S 3/2008 Curthelet
D571,256 S * 6/2008 Curthelet D12/7
D580,821 S * 11/2008 Petit D12/7
D580,823 S * 11/2008 Longpre D12/7
D580,824 S * 11/2008 Longpre et al. D12/7
D581,316 S * 11/2008 Petit D12/7

OTHER PUBLICATIONS

U.S. Appl. No. 29/299,912, filed Jan. 7, 2008. Title: Snowmobile Hood.
U.S. Appl. No. 29/299,915, filed Jan. 7, 2008. Title: Portions of a Snowmobile.
U.S. Appl. No. 29/299,921, filed Jan. 7, 2008. Title: Snowmobile Headlight Glass.
U.S. Appl. No. 29/299,913, filed Jan. 7, 2008. Title: Snowmobile Front Fairing.
U.S. Appl. No. 29/299,926, filed Jan. 7, 2008. Title: Snowmobile Side Panel.
U.S. Appl. No. 29/299,928, filed Jan. 7, 2008. Title: Snowmobile Side Panel.

* cited by examiner

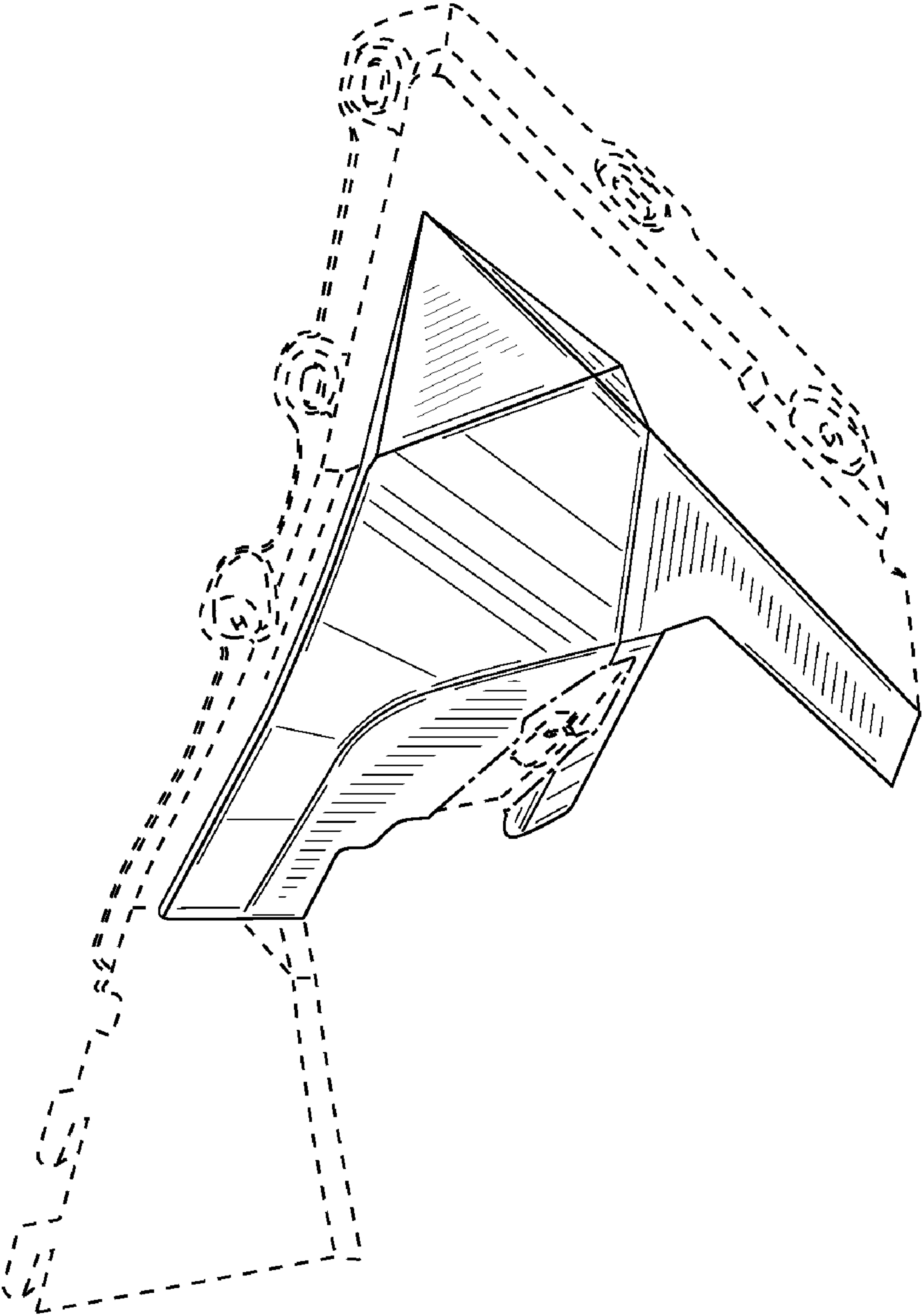

FIG. 1

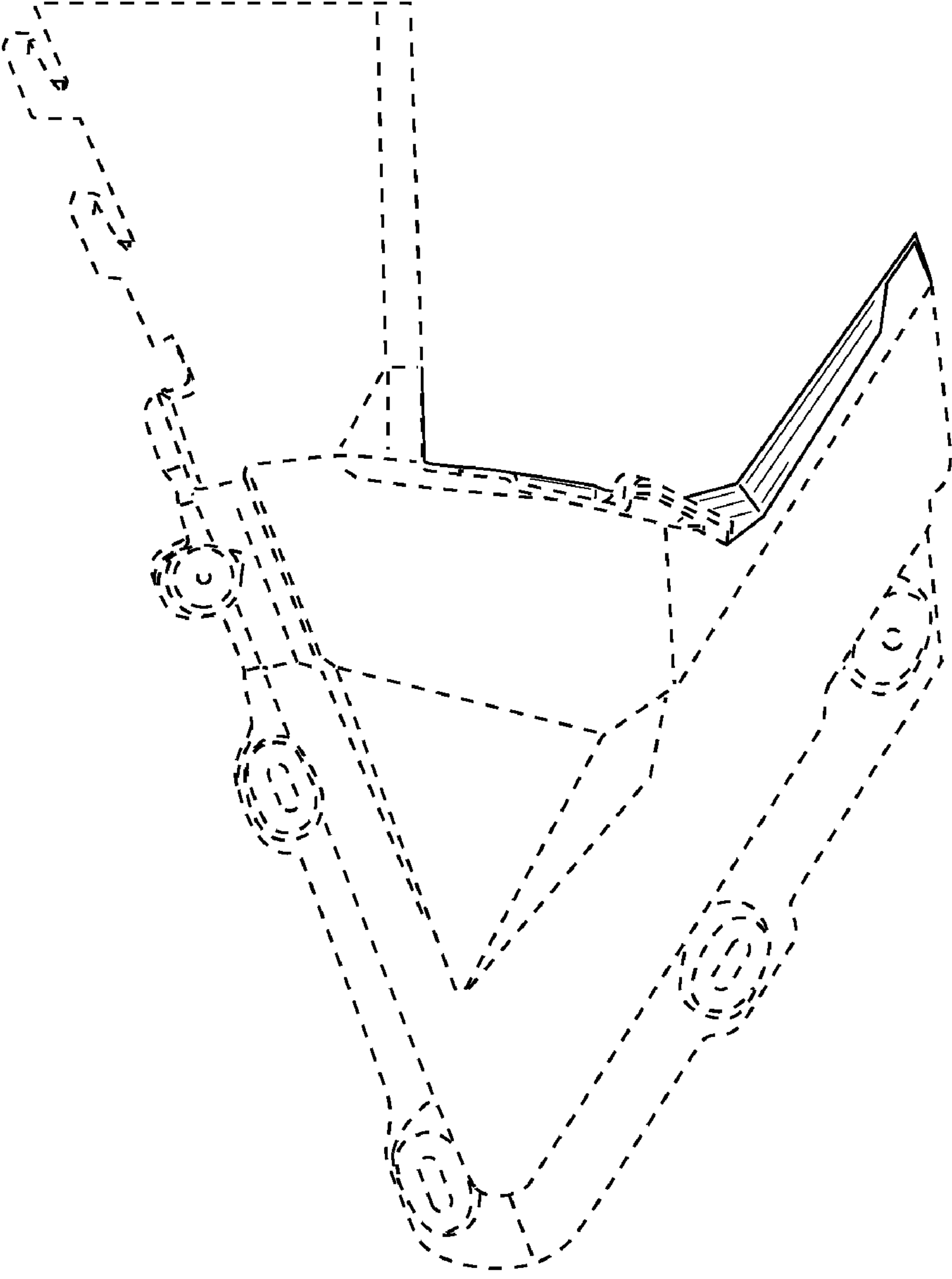

FIG. 2

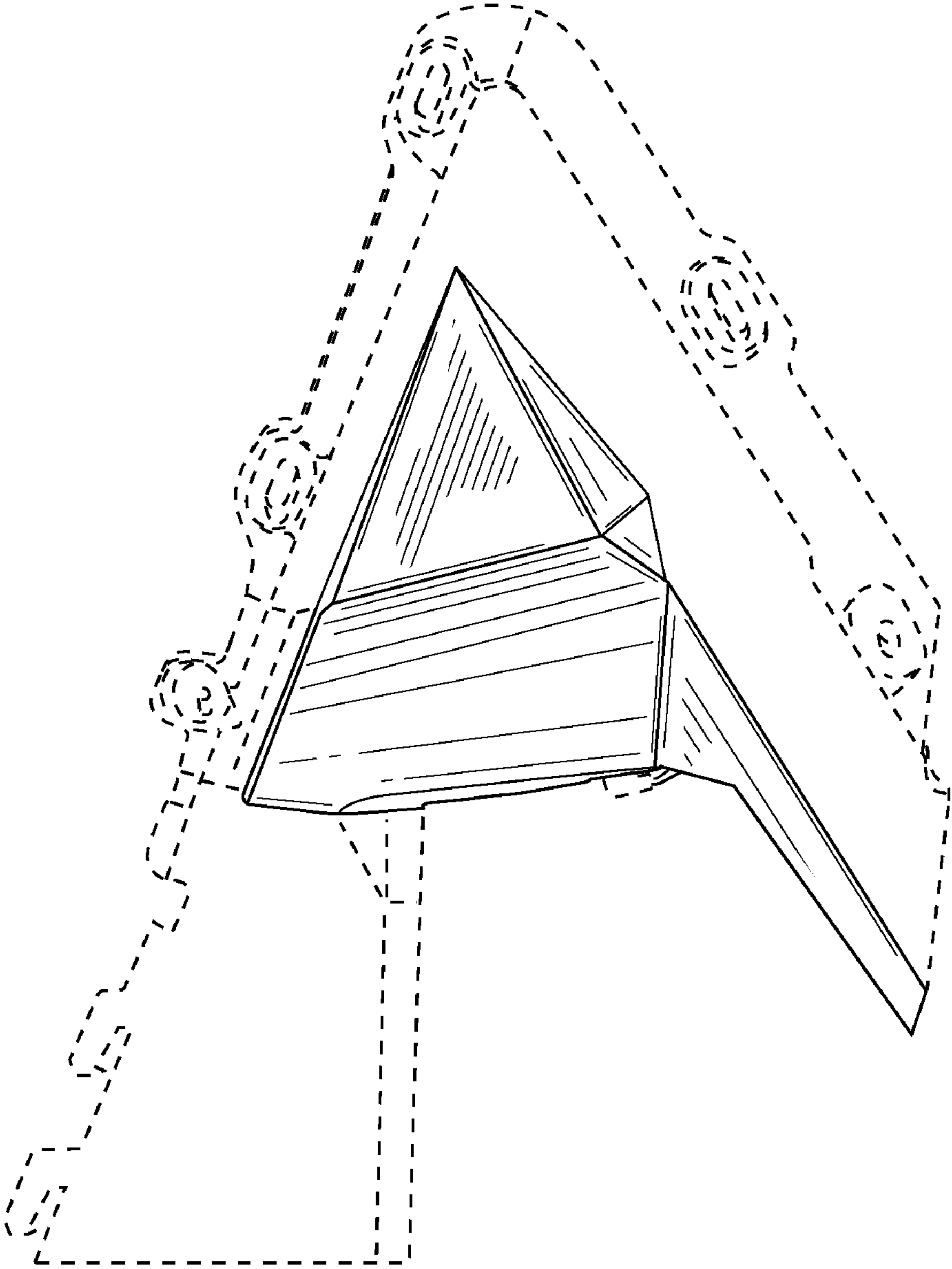

FIG. 3

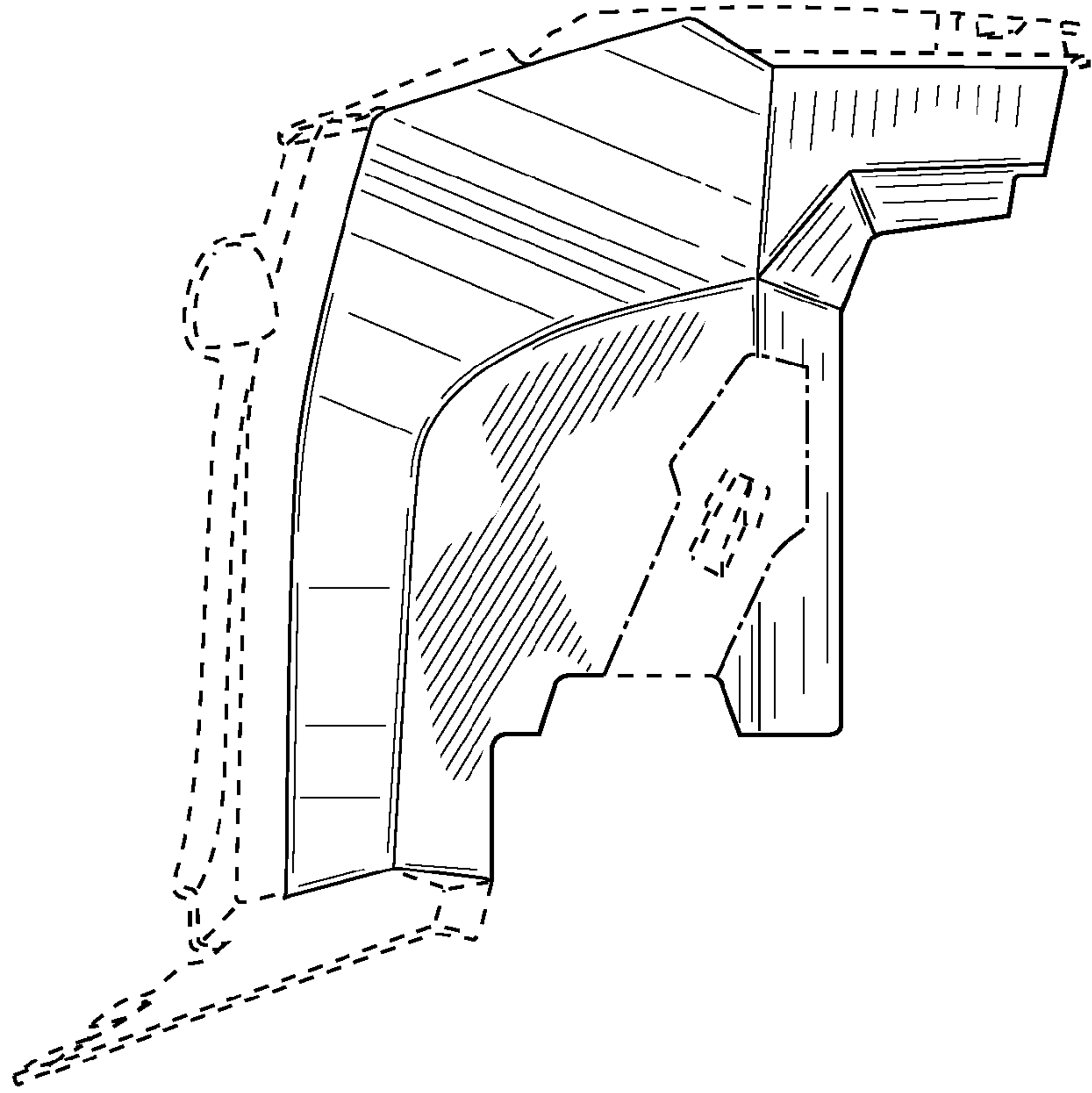

FIG. 4

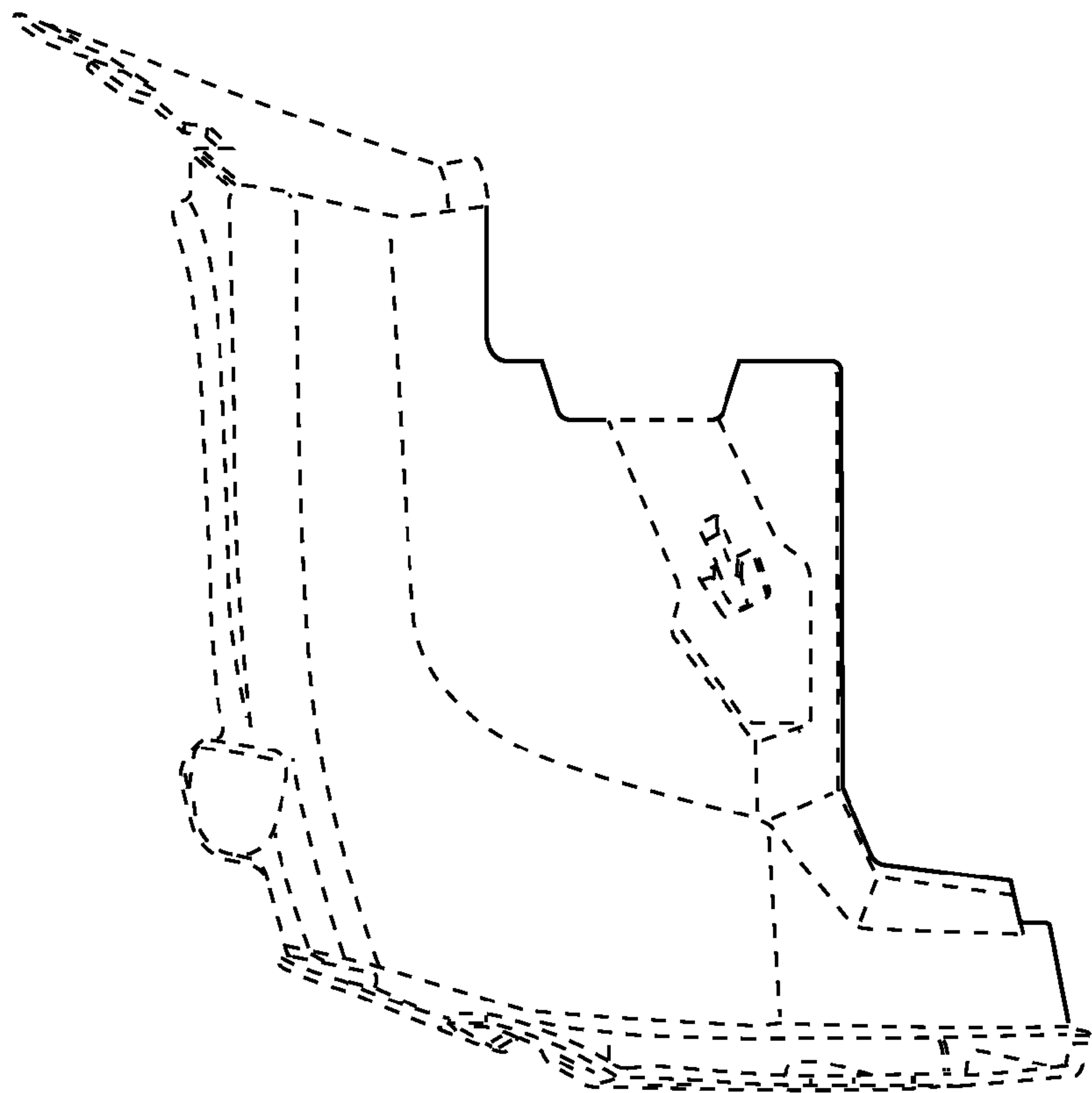

FIG. 5

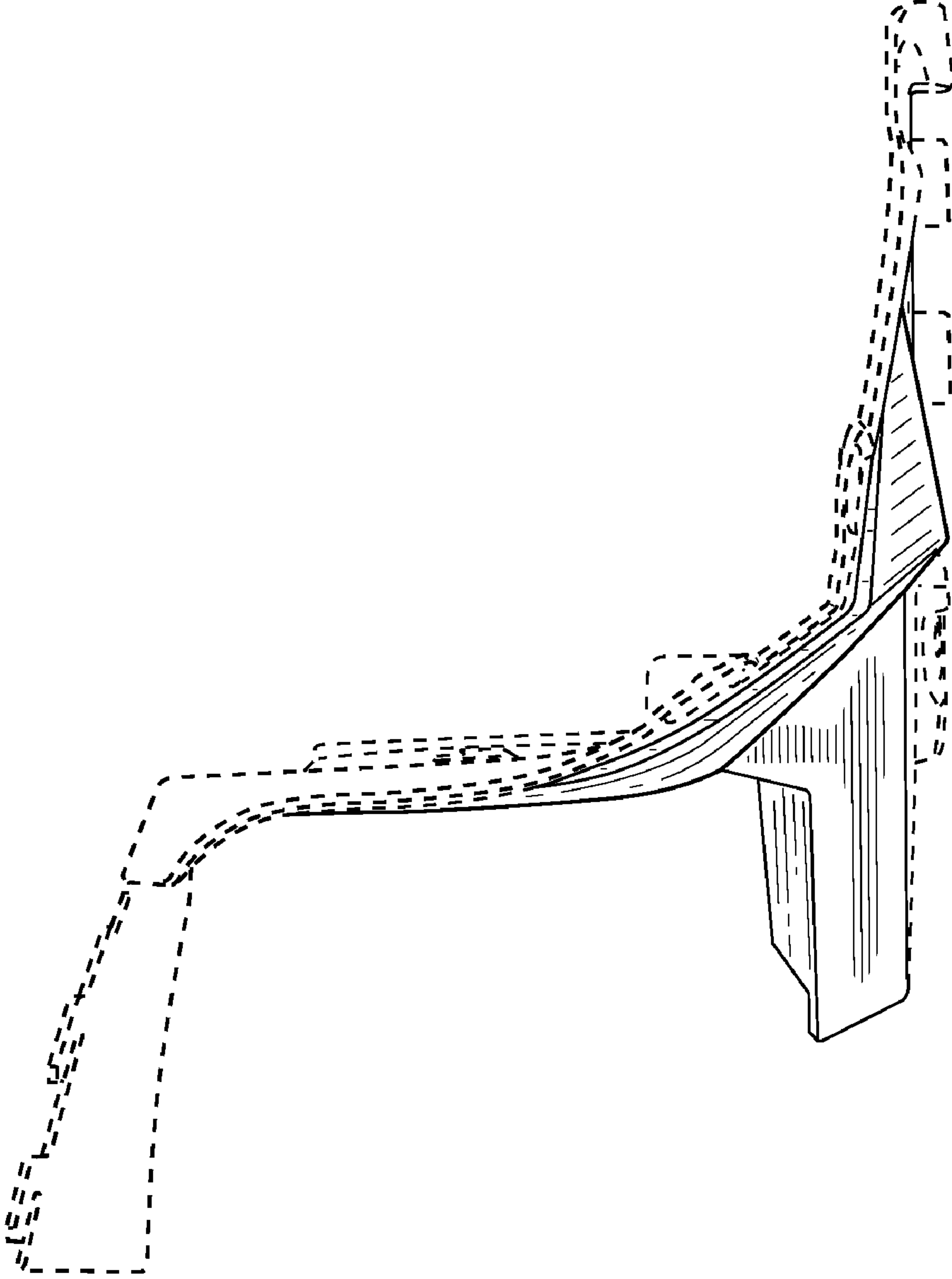

FIG. 6

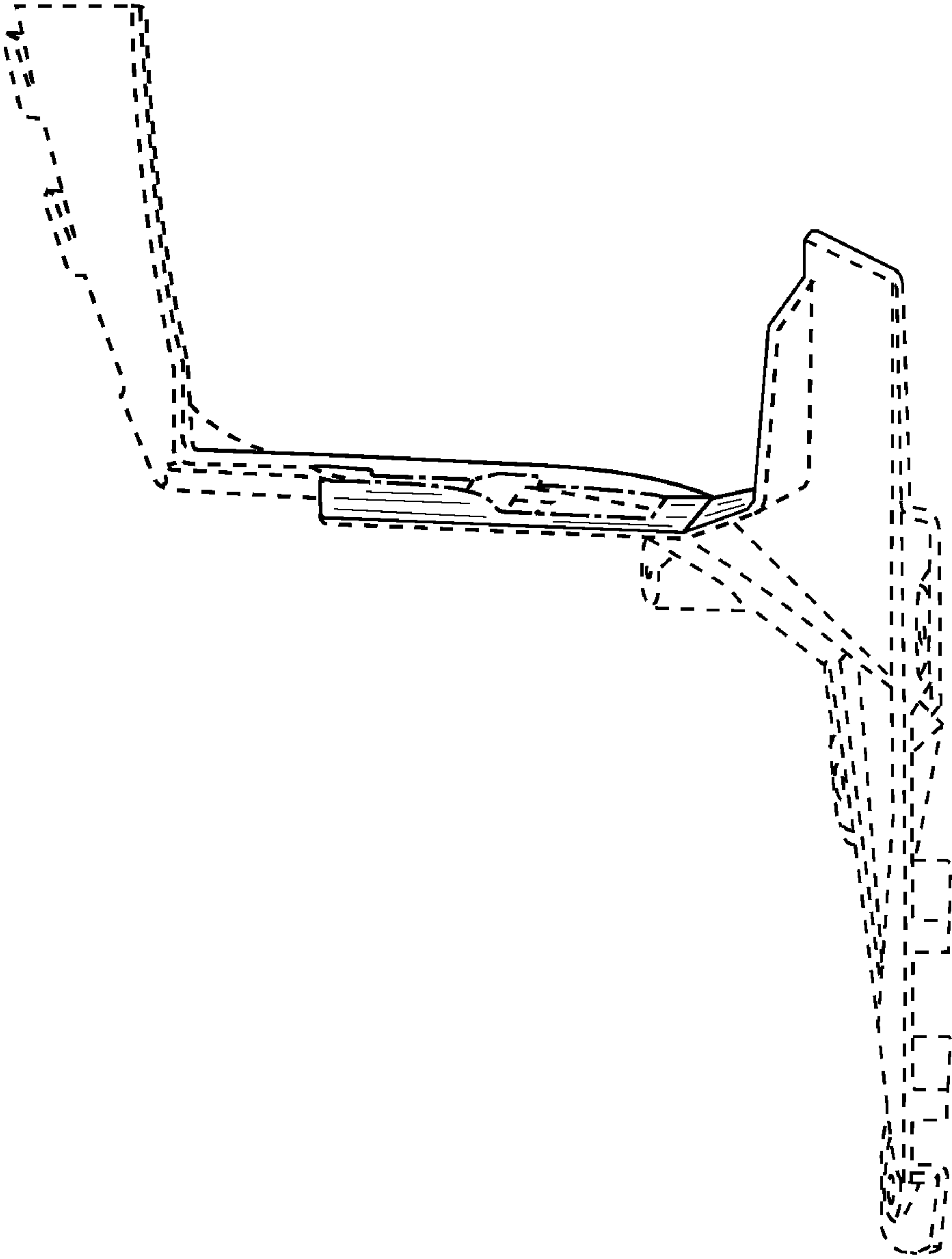

FIG. 7

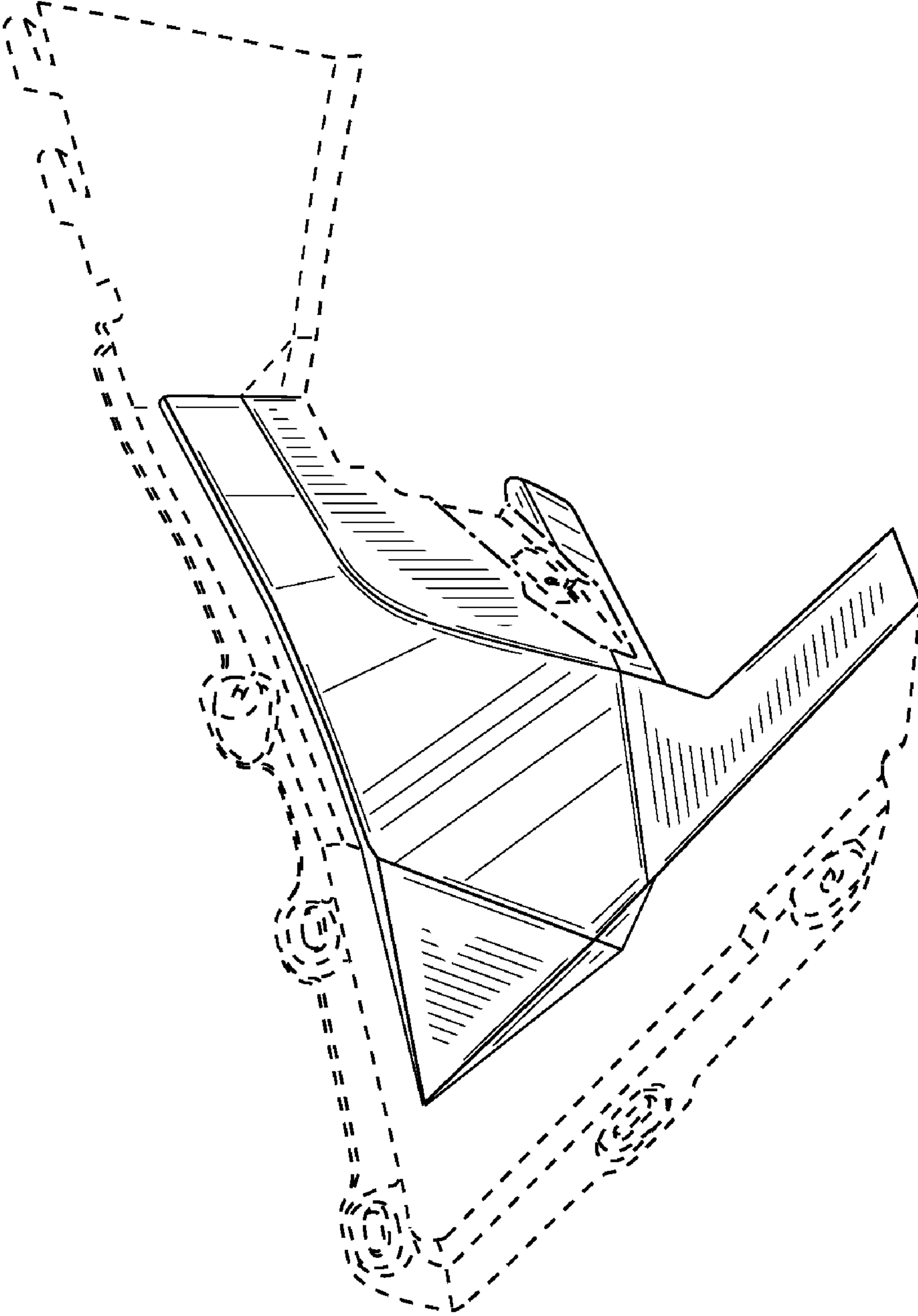

FIG. 8

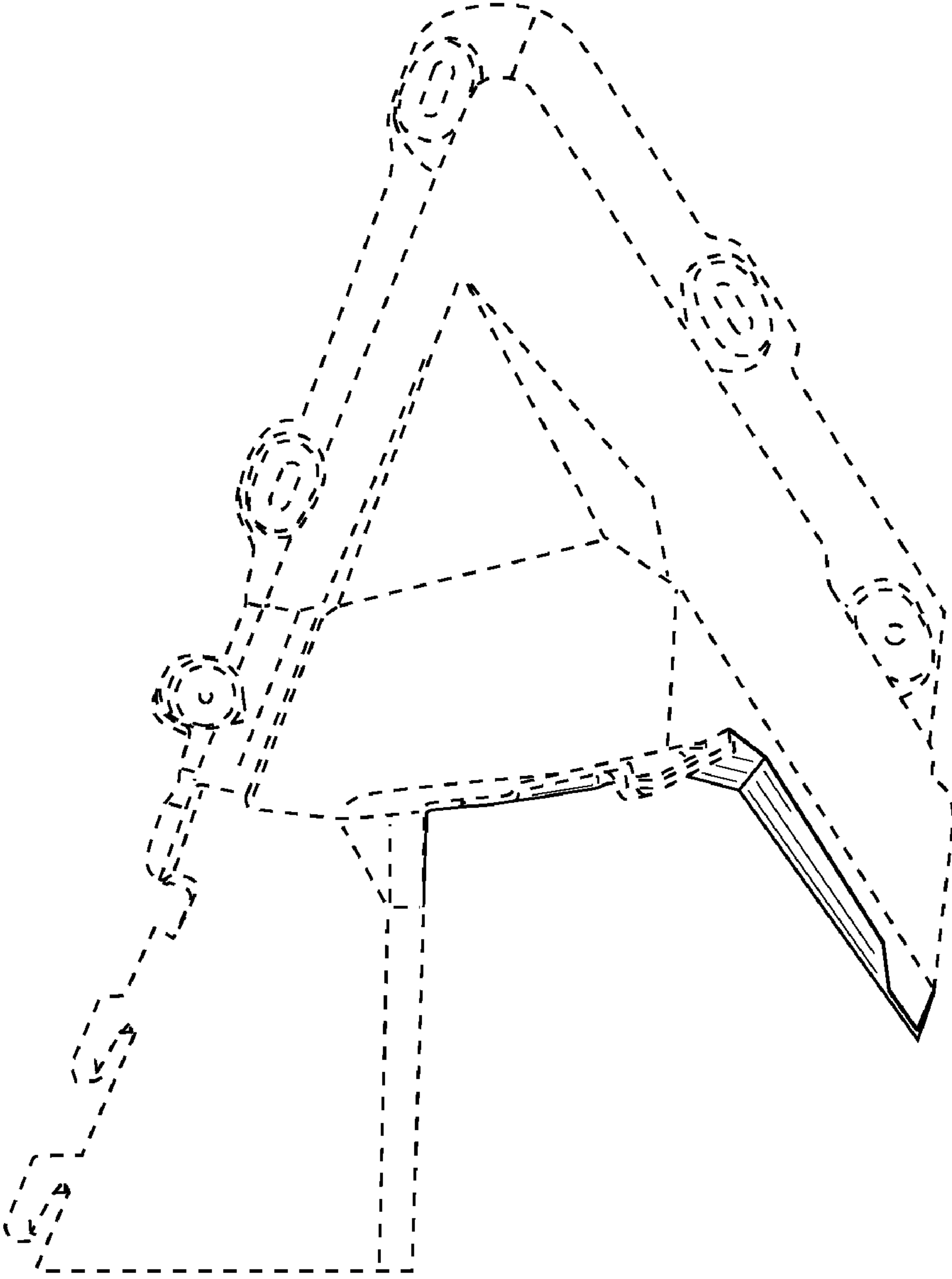

FIG. 9

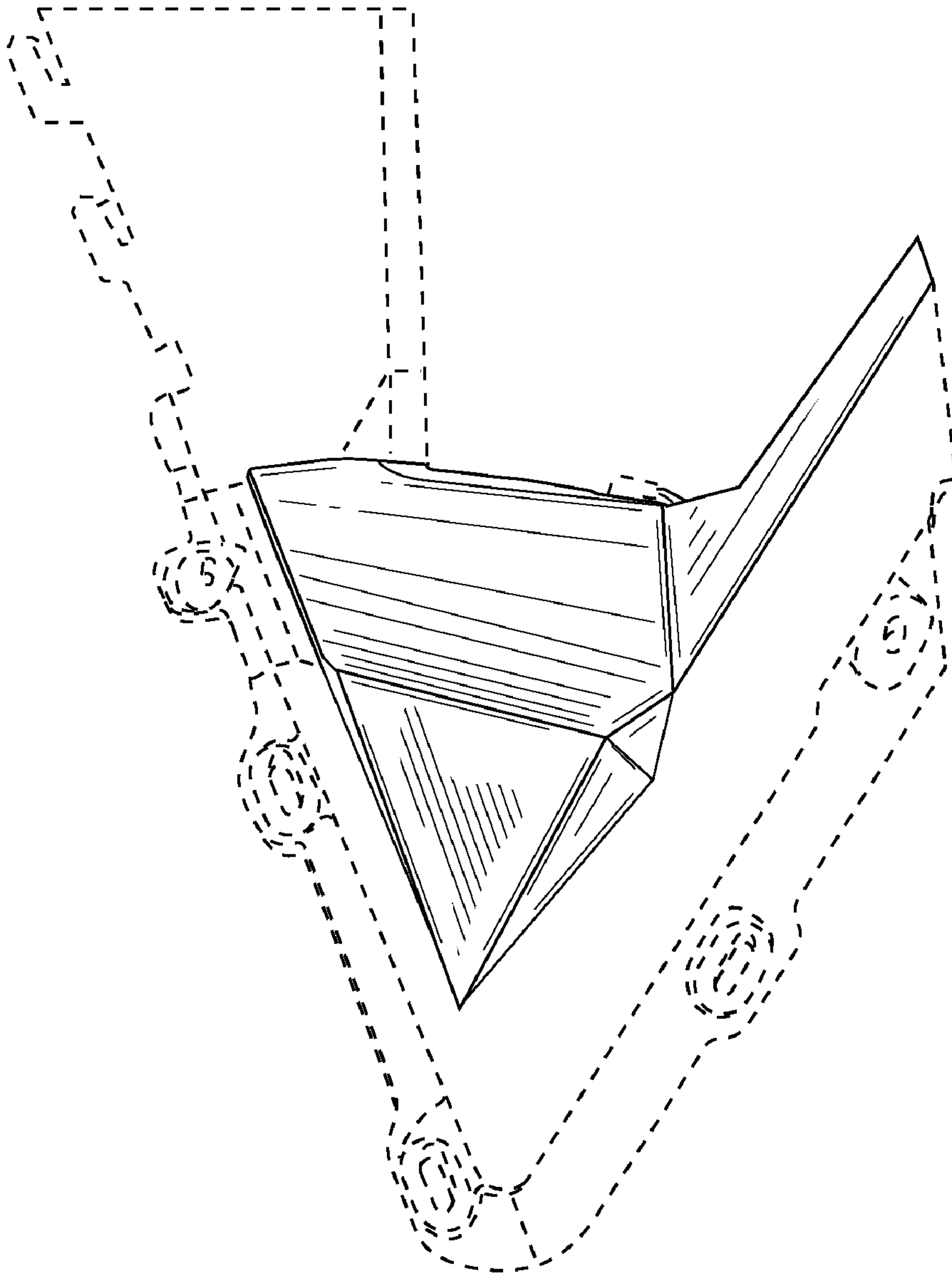

FIG. 10

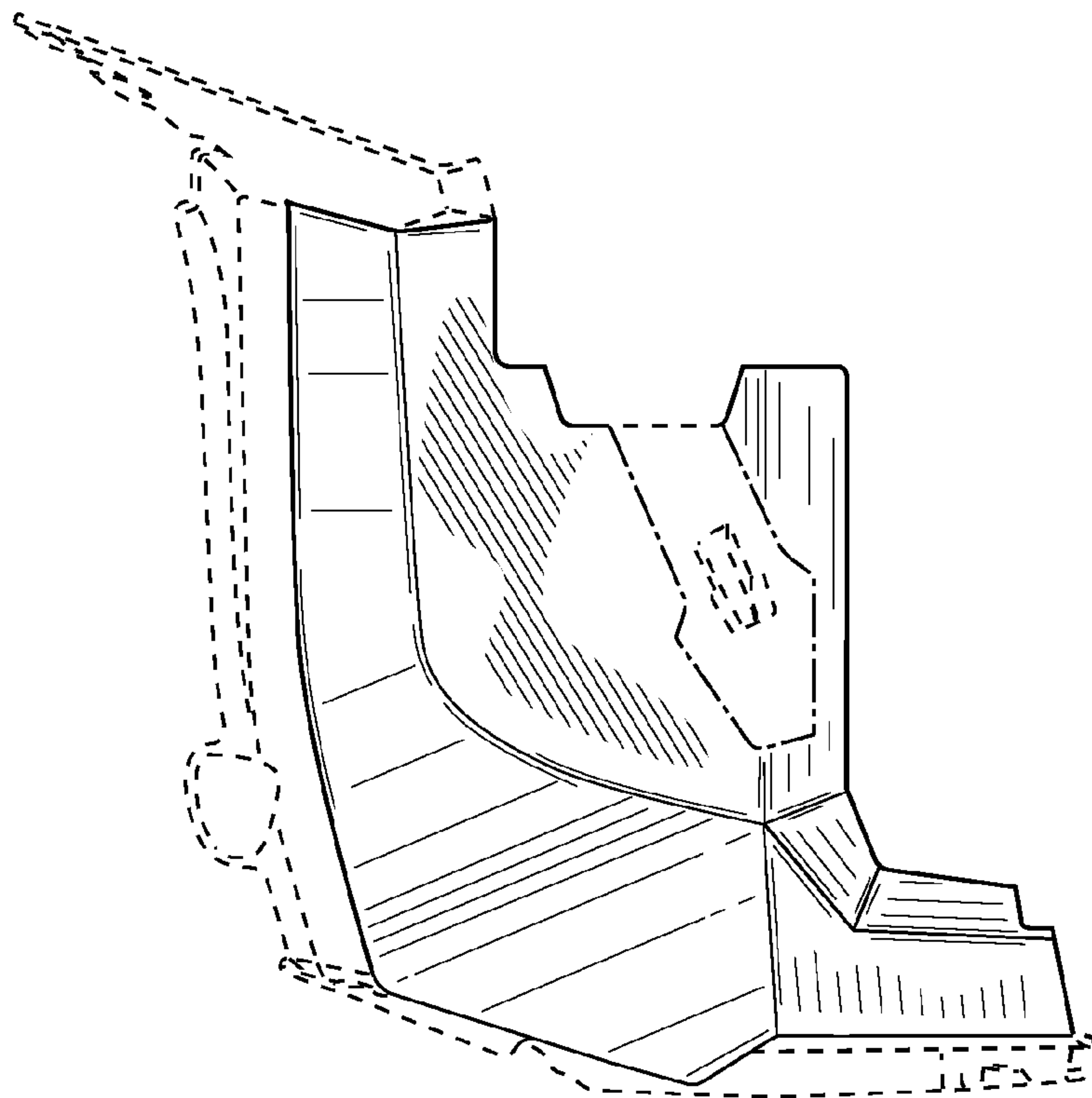

FIG. 12

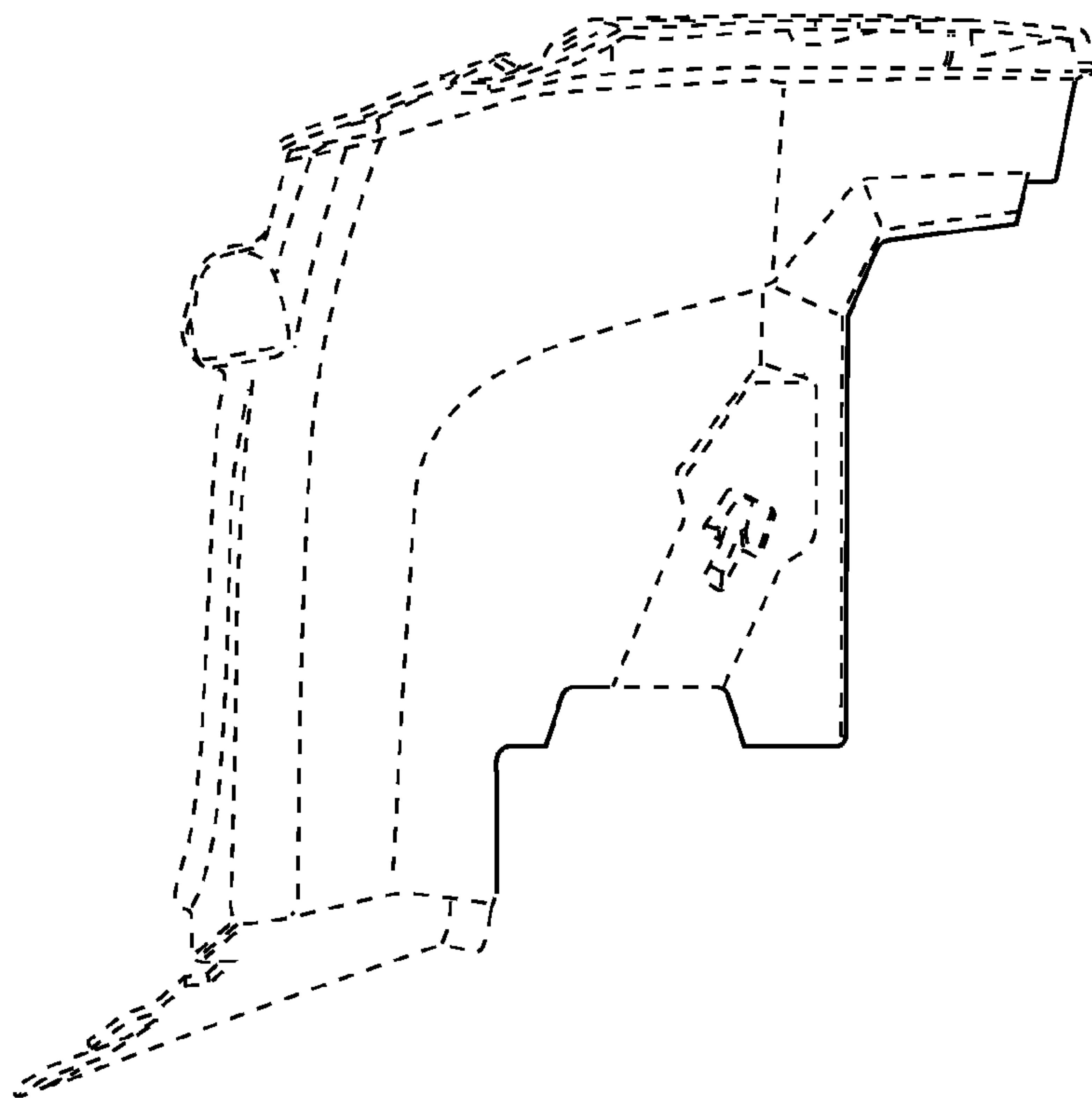

FIG. 11

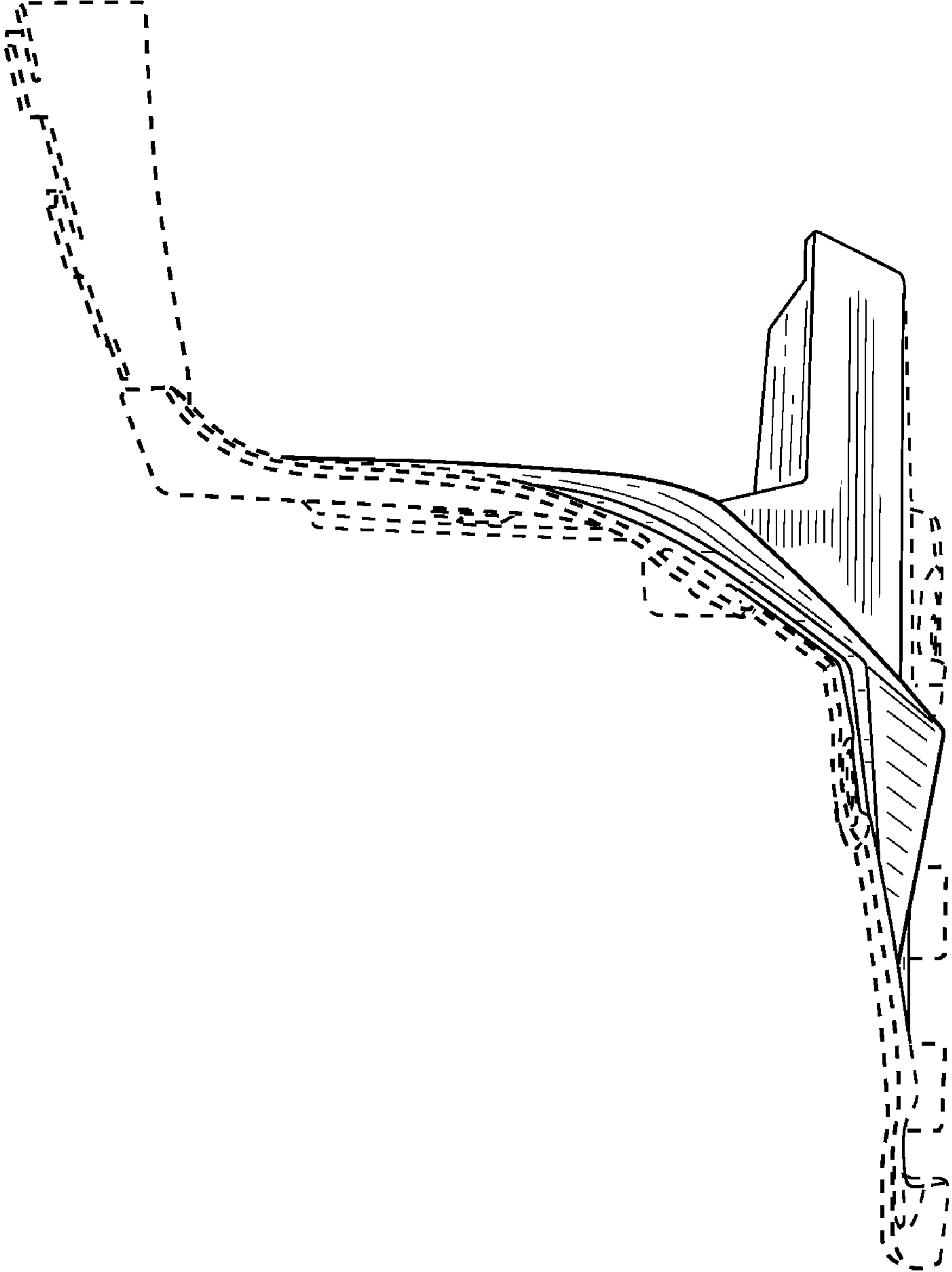

FIG. 13

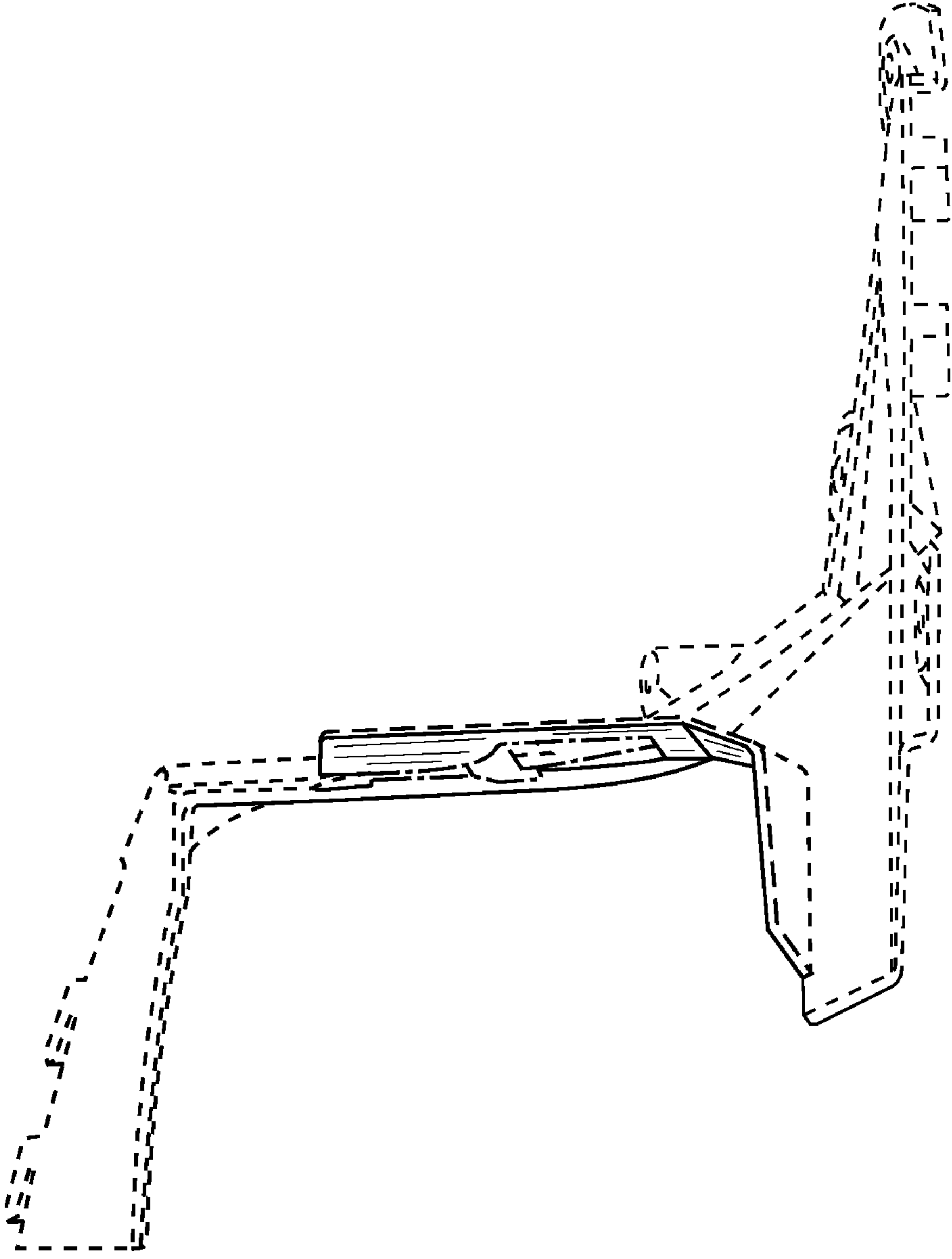

FIG. 14