



US00D594769S

(12) **United States Design Patent**  
**Shin**

(10) **Patent No.:** **US D594,769 S**  
(45) **Date of Patent:** **\*\* Jun. 23, 2009**

(54) **LIGHT BAR FOR EMERGENCY VEHICLES**

(76) Inventor: **David D Shin**, 7322 Madison St.,  
Paramount, CA (US) 90723

(\*\*) Term: **14 Years**

(21) Appl. No.: **29/332,862**

(22) Filed: **Feb. 26, 2009**

(51) **LOC (9) Cl.** ..... **10-05**

(52) **U.S. Cl.** ..... **D10/114**

(58) **Field of Classification Search** ..... D10/109,  
D10/111, 114; D26/39-31, 60; 340/815.45,  
340/908.1, 463; 362/311, 373, 35, 183, 200,  
362/196, 191, 459, 460-463, 465  
See application file for complete search history.

(56) **References Cited**

**U.S. PATENT DOCUMENTS**

|           |     |         |                |         |
|-----------|-----|---------|----------------|---------|
| 2,814,029 | A   | 11/1957 | Mcrea          |         |
| 3,278,741 | A   | 10/1966 | Wood           |         |
| D249,250  | S   | 9/1978  | Peirish, Jr.   |         |
| 4,357,595 | A   | 11/1982 | Gosswiller     |         |
| D274,001  | S   | 5/1984  | Sailers        |         |
| 4,620,268 | A   | 10/1986 | Ferenc         |         |
| 4,937,711 | A   | 6/1990  | Shuen          |         |
| 4,956,753 | A   | 9/1990  | Renfrew        |         |
| D324,921  | S   | 3/1992  | Stanuch et al. |         |
| D345,316  | S * | 3/1994  | Green et al.   | D10/114 |
| D355,142  | S   | 2/1995  | Wagner         |         |
| 5,452,188 | A * | 9/1995  | Green et al.   | 362/493 |
| D400,675  | S   | 11/1998 | Sopko          |         |
| D410,402  | S * | 6/1999  | Stein et al.   | D10/114 |
| D419,249  | S   | 1/2000  | Ford et al.    |         |
| D432,038  | S * | 10/2000 | Sasaki et al.  | D10/114 |
| D432,444  | S * | 10/2000 | Sasaki et al.  | D10/114 |
| D442,106  | S   | 5/2001  | Stein et al.   |         |
| 6,461,008 | B1  | 10/2002 | Pederson       |         |
| D476,253  | S * | 6/2003  | Stein et al.   | D10/114 |

|              |      |         |          |         |
|--------------|------|---------|----------|---------|
| 6,590,502    | B1   | 7/2003  | Pederson |         |
| 6,623,151    | B2   | 9/2003  | Pederson |         |
| D491,482     | S *  | 6/2004  | Chiang   | D10/114 |
| 6,788,217    | B2   | 9/2004  | Pederson |         |
| 6,789,930    | B2   | 9/2004  | Pederson |         |
| 6,814,459    | B2   | 11/2004 | Pederson |         |
| 6,822,578    | B2   | 11/2004 | Pederson |         |
| 7,033,036    | B2   | 4/2006  | Pederson |         |
| D545,230     | S *  | 6/2007  | Jalala   | D10/114 |
| 7,394,398    | B2   | 7/2008  | Pederson |         |
| D585,318     | S *  | 1/2009  | Jalala   | D10/114 |
| 2008/0218328 | A1 * | 9/2008  | Chiu     | 340/468 |

\* cited by examiner

*Primary Examiner*—Caron Veynar

*Assistant Examiner*—George D Kirschbaum

(57) **CLAIM**

The ornamental design for a light bar for emergency vehicles,  
as shown and described.

**DESCRIPTION**

FIG. 1 is a top, right perspective view of a light bar for  
emergency vehicles showing my new design;

FIG. 2 is a top view thereof;

FIG. 3 is a bottom view thereof;

FIG. 4 is a front view thereof;

FIG. 5 is a back view thereof;

FIG. 6 is a left view thereof;

FIG. 7 is a right view thereof; and,

FIG. 8 is a view of the light bar for emergency vehicles  
mounted on the roof of vehicle.

The broken lines in FIG. 8 depict environmental subject mat-  
ter of mounting hardware for the invention on a vehicle only  
and form no part of the claimed design.

**1 Claim, 5 Drawing Sheets**

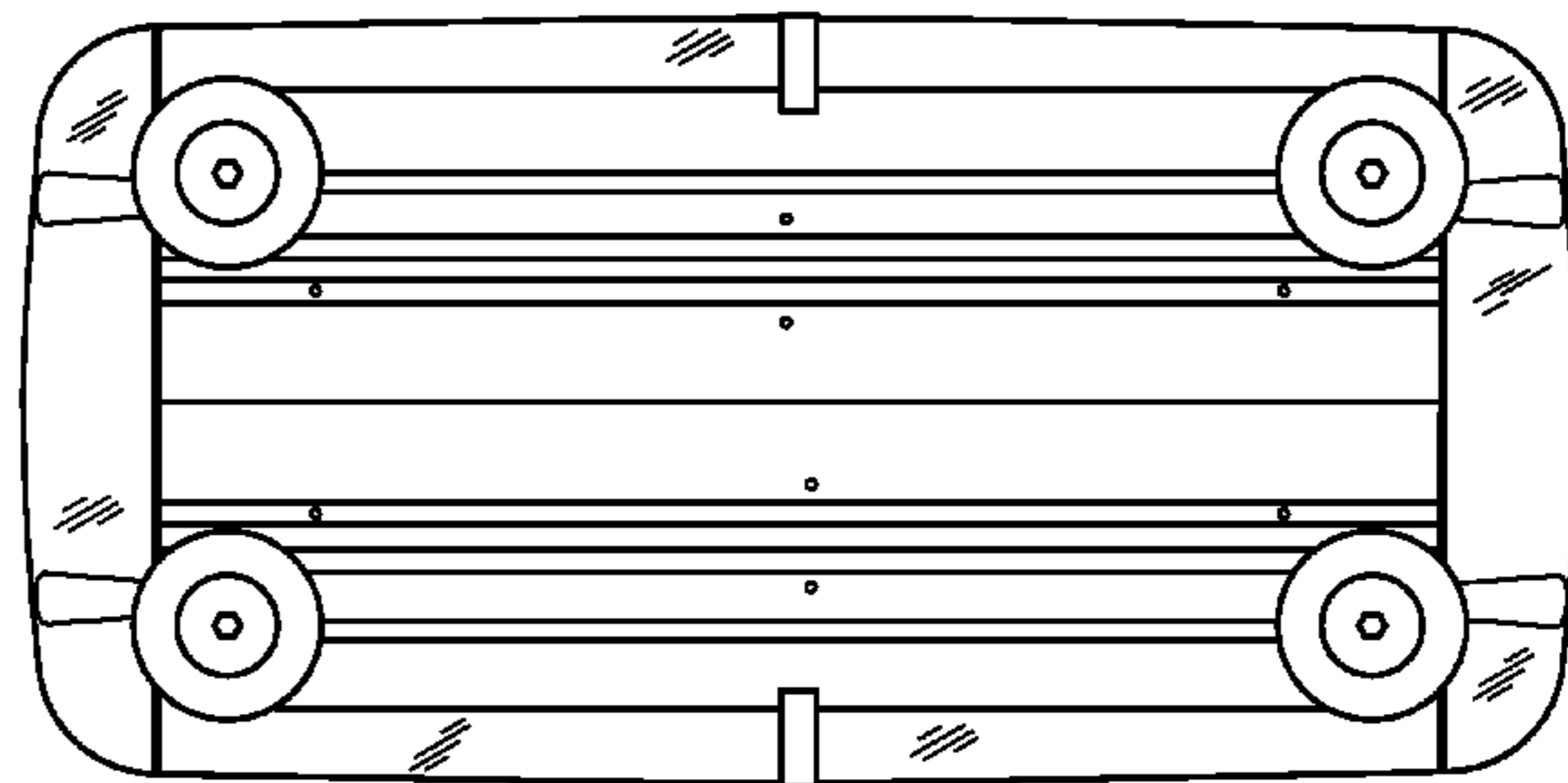
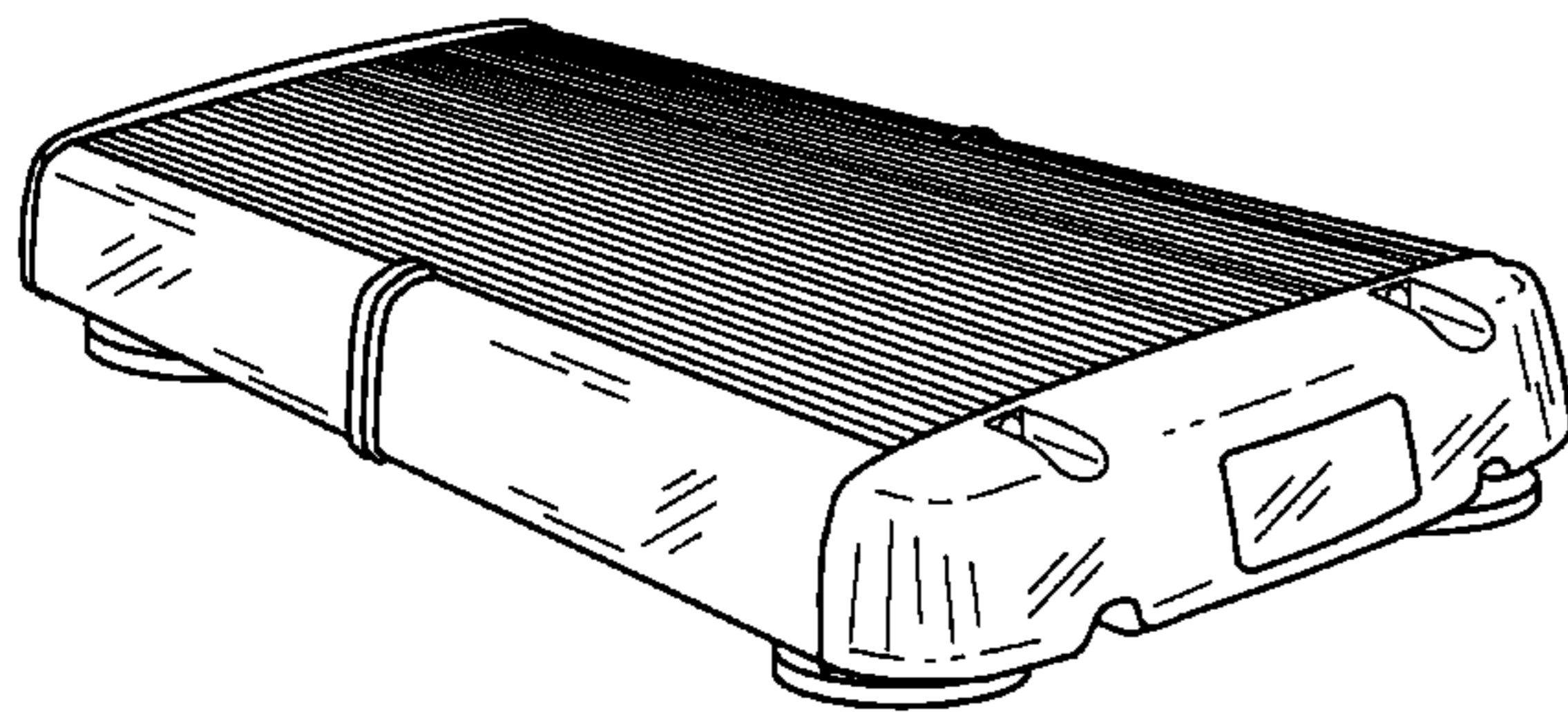

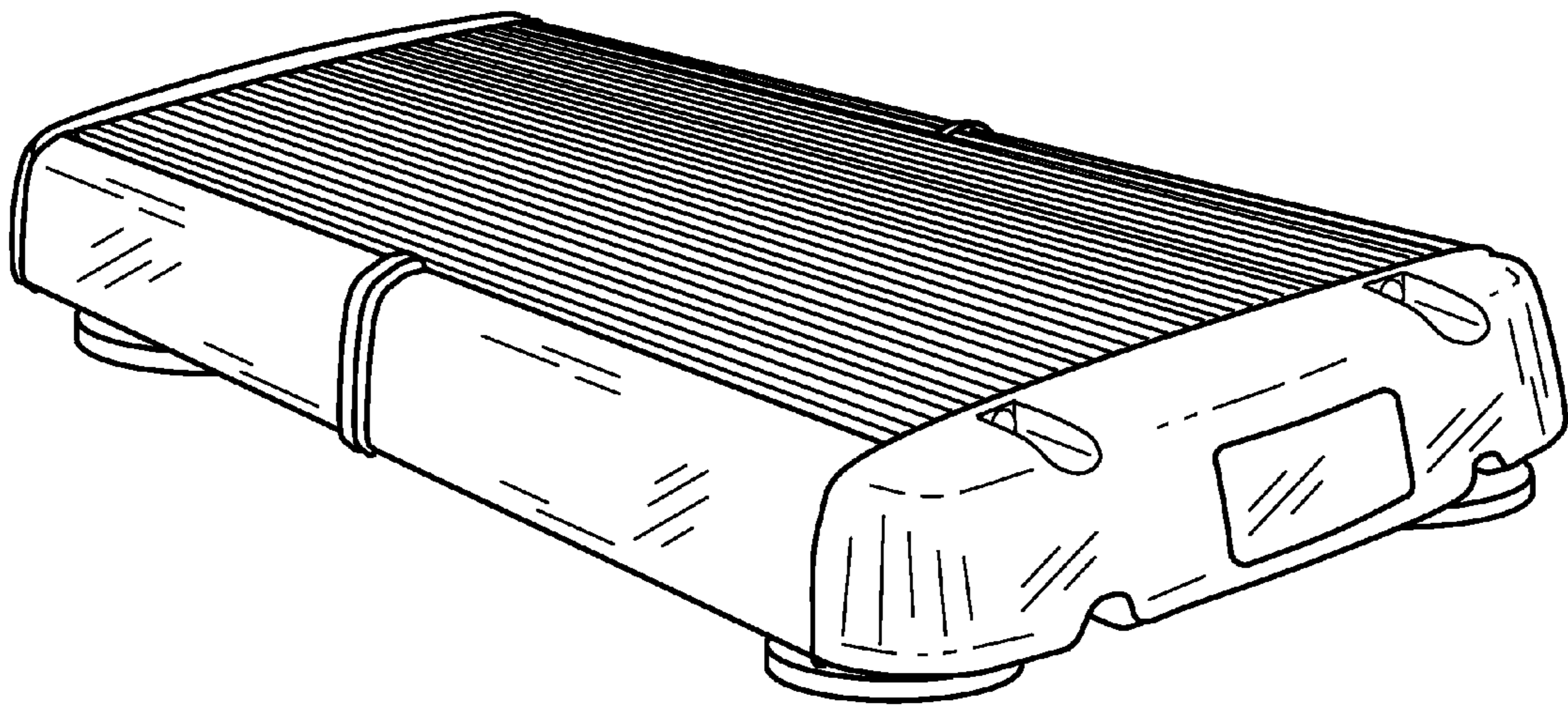

**FIG. 1**

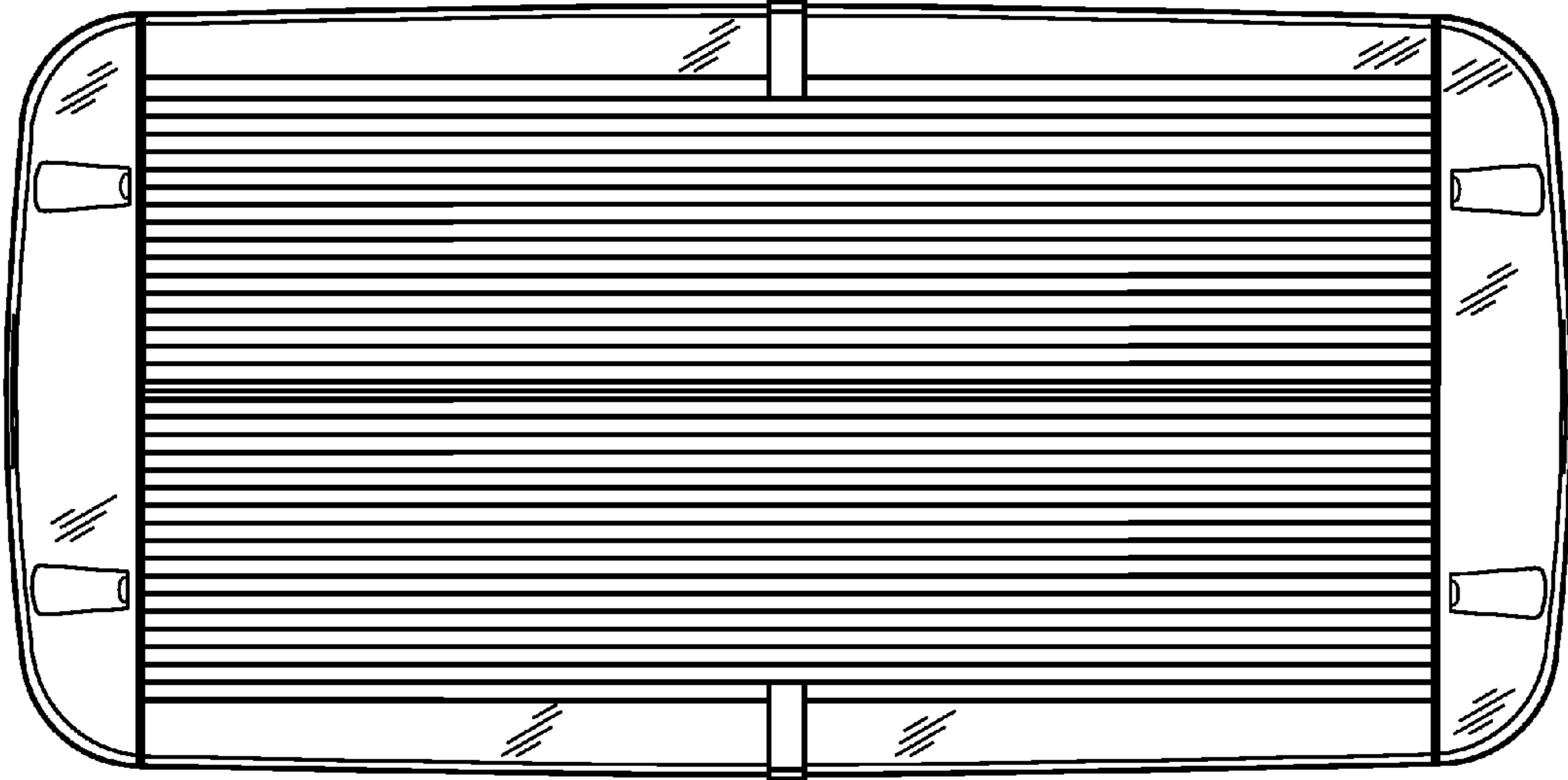

FIG. 2

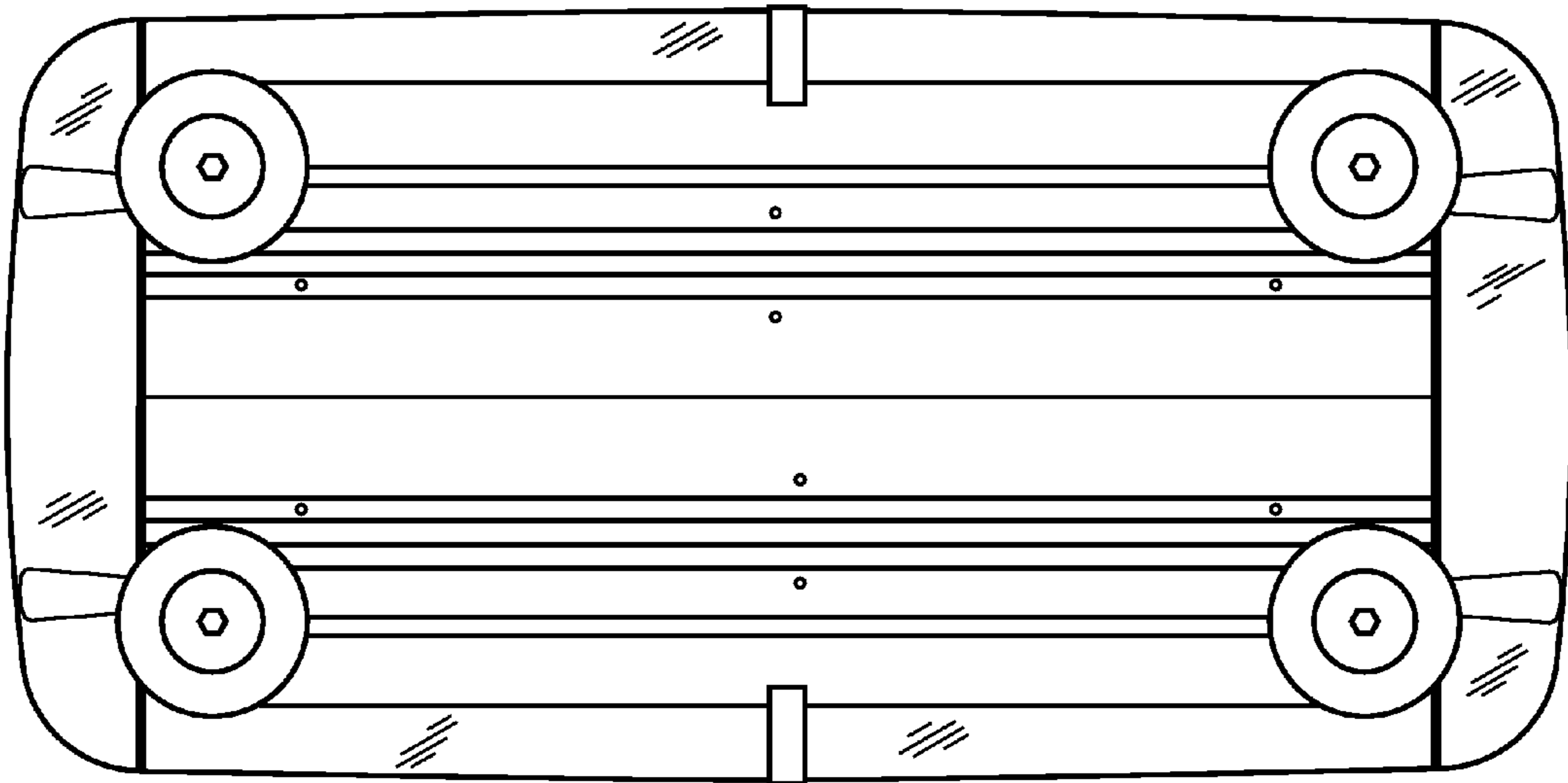
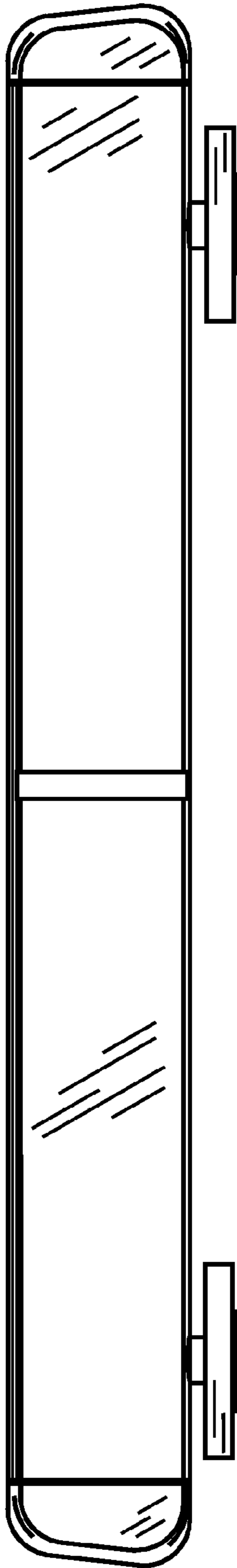
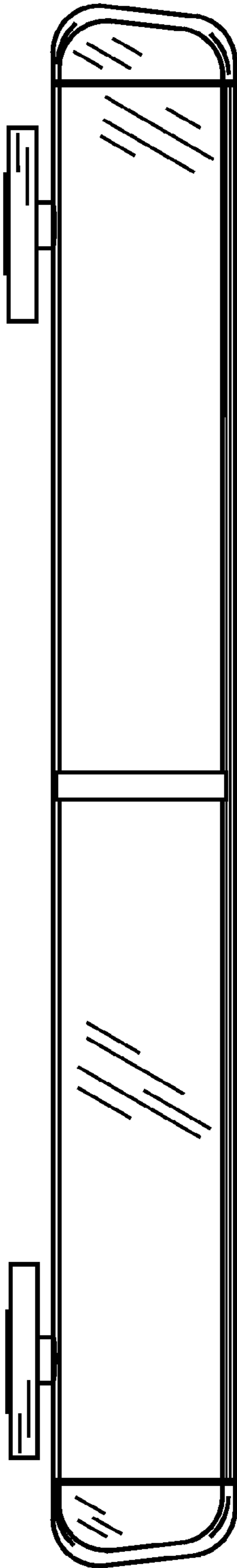

FIG. 3



**FIG. 4**



**FIG. 5**

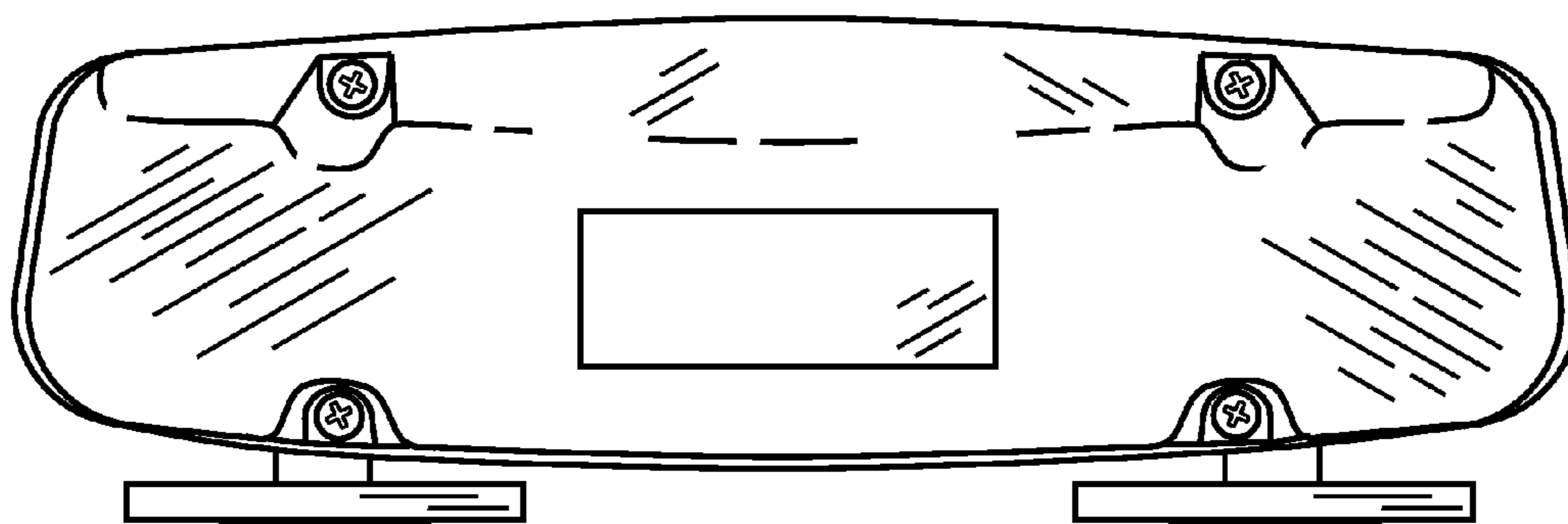

FIG. 6

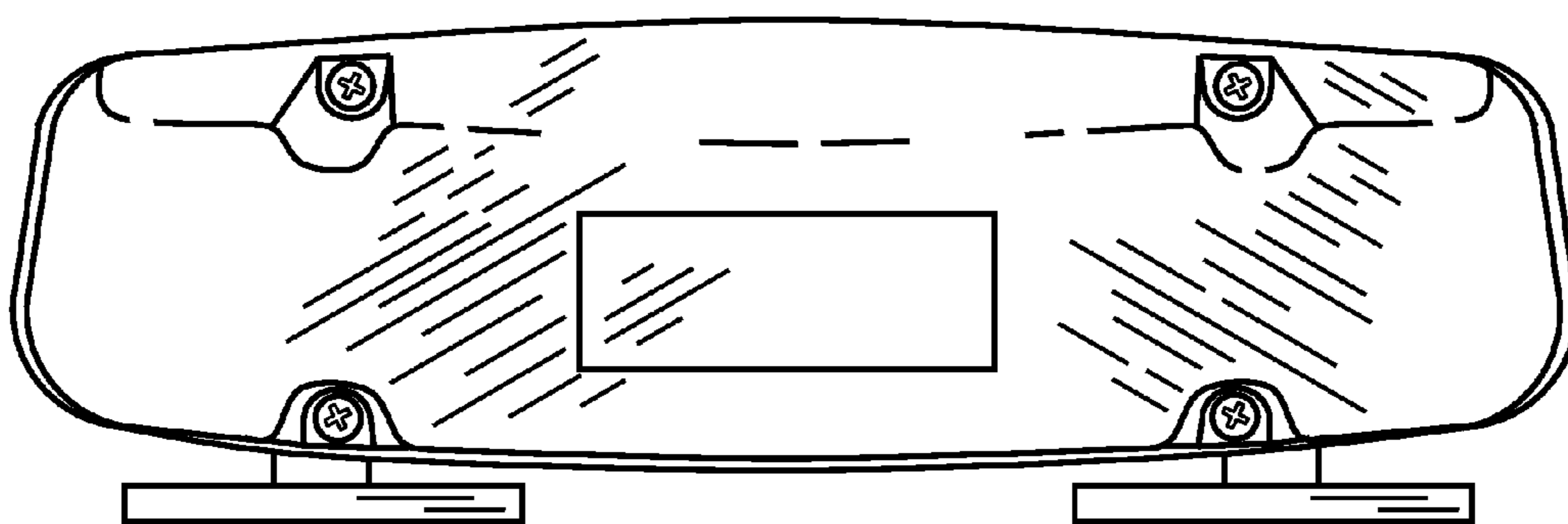

FIG. 7

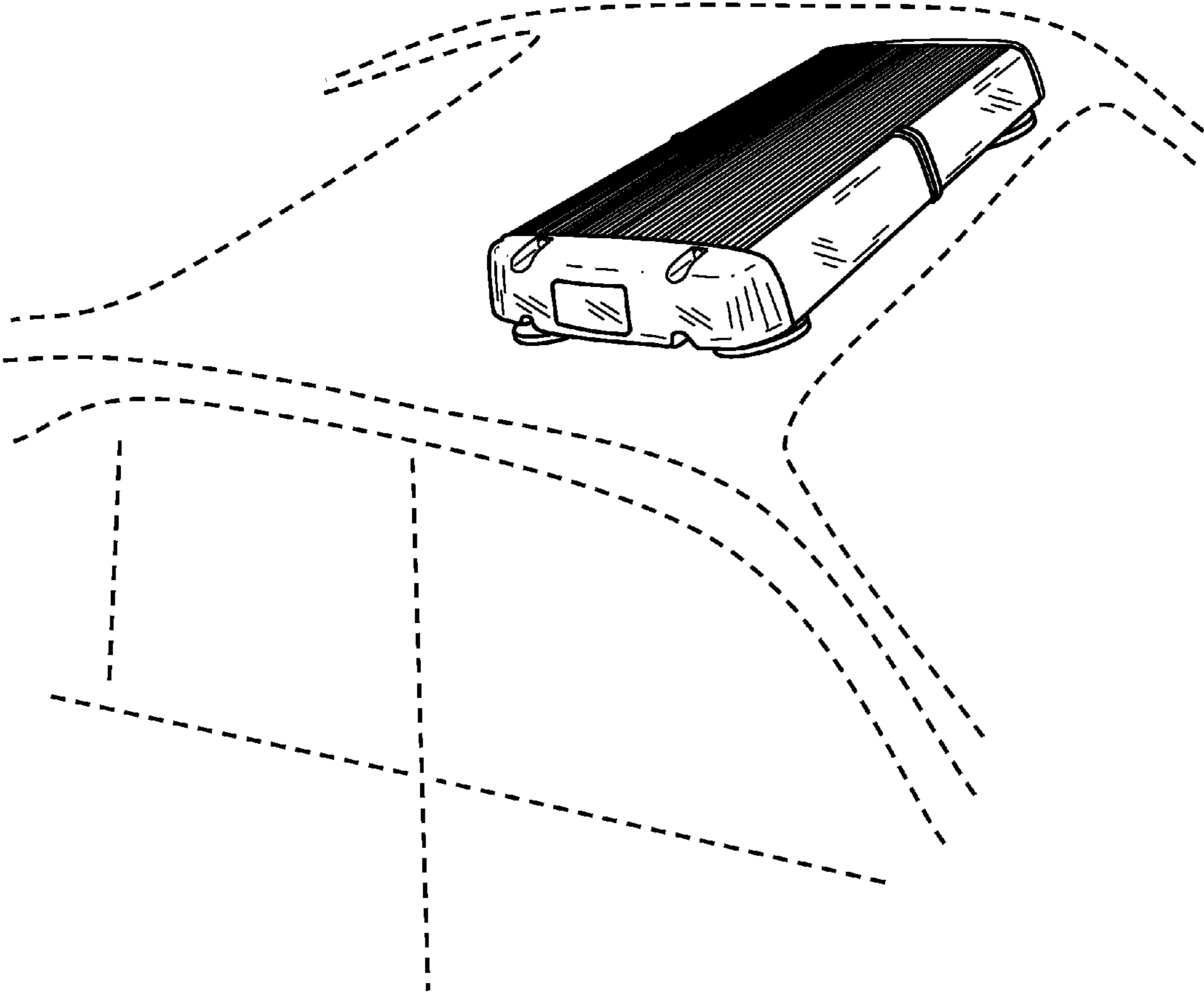

FIG. 8