

US00D594624S

(12) **United States Design Patent**  
**Shibata et al.**

(10) **Patent No.:** **US D594,624 S**  
(45) **Date of Patent:** **\*\* Jun. 16, 2009**

(54) **FORKLIFT TRUCK**

(75) Inventors: **Naoki Shibata**, Nagoya (JP); **Akihiro Ishigami**, Sagamihara (JP); **Yuichi Ishimura**, Sagamihara (JP); **Nobutaka Umezawa**, Sagamihara (JP)

(73) Assignee: **Mitsubishi Heavy Industries. Ltd.**, Tokyo (JP)

(\*\*) Term: **14 Years**

(21) Appl. No.: **29/309,343**

(22) Filed: **Jul. 29, 2008**

(30) **Foreign Application Priority Data**

Jan. 31, 2008 (JP) ..... 2008-002098

(51) **LOC (9) Cl.** ..... **12-05**

(52) **U.S. Cl.** ..... **D34/35**

(58) **Field of Classification Search** ..... D34/34,  
D34/35; 414/685, 465; 180/89.12, 89.14,  
180/89.17; 187/237, 238, 414

See application file for complete search history.

(56) **References Cited**

**U.S. PATENT DOCUMENTS**

|              |         |                      |        |
|--------------|---------|----------------------|--------|
| D374,752 S * | 10/1996 | Lee et al. ....      | D34/34 |
| D379,020 S * | 4/1997  | Avitan .....         | D34/34 |
| D386,872 S * | 11/1997 | Rick et al. ....     | D34/34 |
| D386,875 S * | 11/1997 | Kim .....            | D34/34 |
| D386,877 S * | 11/1997 | Russey et al. ....   | D34/34 |
| D518,268 S * | 3/2006  | Stark .....          | D34/34 |
| D557,873 S * | 12/2007 | Miura .....          | D34/35 |
| D558,424 S * | 12/2007 | Miura .....          | D34/35 |
| D565,825 S * | 4/2008  | Shibata et al. ....  | D34/34 |
| D570,575 S * | 6/2008  | Stark .....          | D34/34 |
| D571,074 S * | 6/2008  | Buchmann et al. .... | D34/35 |
| D579,169 S * | 10/2008 | Mori et al. ....     | D34/35 |
| D579,170 S * | 10/2008 | Mori et al. ....     | D34/35 |
| D579,171 S * | 10/2008 | Mori et al. ....     | D34/35 |
| D579,622 S * | 10/2008 | Kim .....            | D34/34 |

|              |         |                     |        |
|--------------|---------|---------------------|--------|
| D579,623 S * | 10/2008 | Kim .....           | D34/34 |
| D582,625 S * | 12/2008 | Mori et al. ....    | D34/35 |
| D584,873 S * | 1/2009  | Kuraoka et al. .... | D34/34 |
| D585,624 S * | 1/2009  | Mori et al. ....    | D34/34 |

**FOREIGN PATENT DOCUMENTS**

|    |                 |         |
|----|-----------------|---------|
| EP | 0005444168-0001 | 10/2006 |
| JP | D917259         | 1/1995  |
| JP | D1156836        | 9/2002  |

**OTHER PUBLICATIONS**

Japanese Office Action mailed Jun. 10, 2008 for Japanese Design Application No. 2008-002098 w/partial English translation.

\* cited by examiner

*Primary Examiner*—Cynthia E Ramirez

(74) *Attorney, Agent, or Firm*—Wenderoth, Lind & Ponack, L.L.P.

(57) **CLAIM**

The ornamental design for a forklift truck, as shown and described.

**DESCRIPTION**

FIG. 1 is a front view of a forklift truck showing our new design;

FIG. 2 is a rear view thereof;

FIG. 3 is a top plan view thereof;

FIG. 4 is a bottom plan view thereof;

FIG. 5 is a right side view thereof;

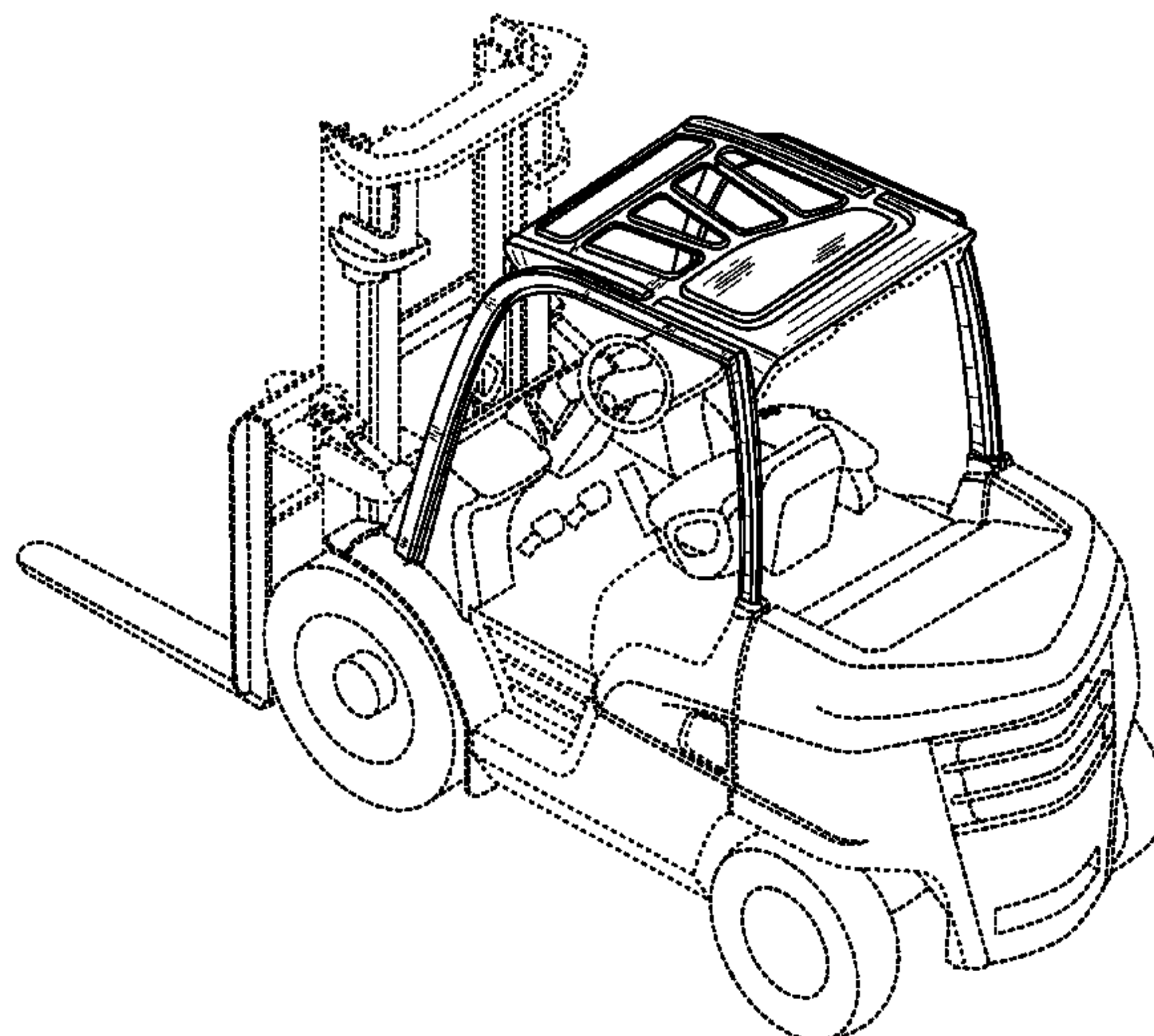
FIG. 6 is a left side view thereof; and,

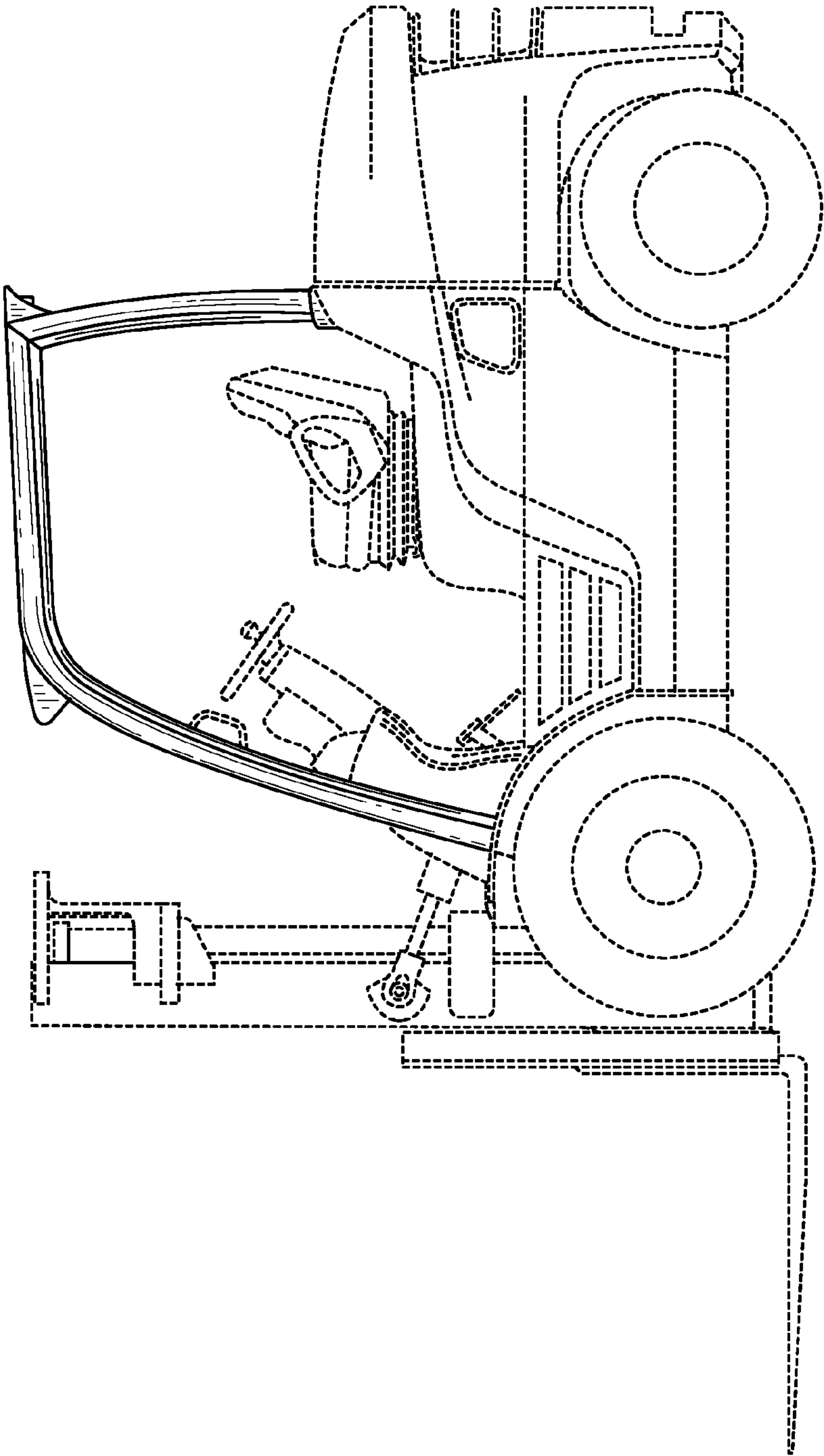
FIG. 7 is a front perspective view thereof.

The solid line indicates a portion to be registered as a partial design.

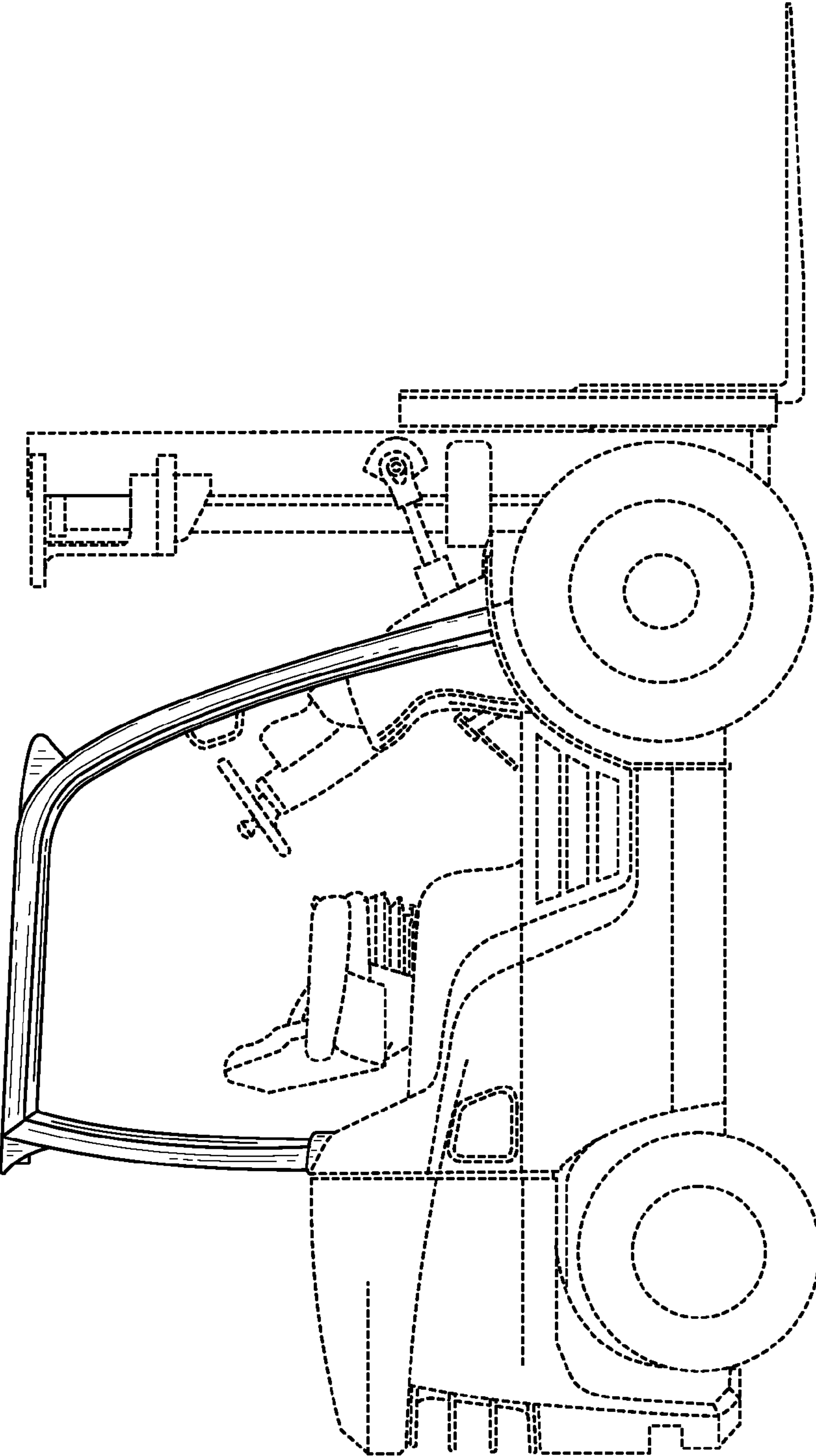
The broken lines on the figures are included for the purpose of illustrating environment and form no part of the claimed design.

**1 Claim, 7 Drawing Sheets**

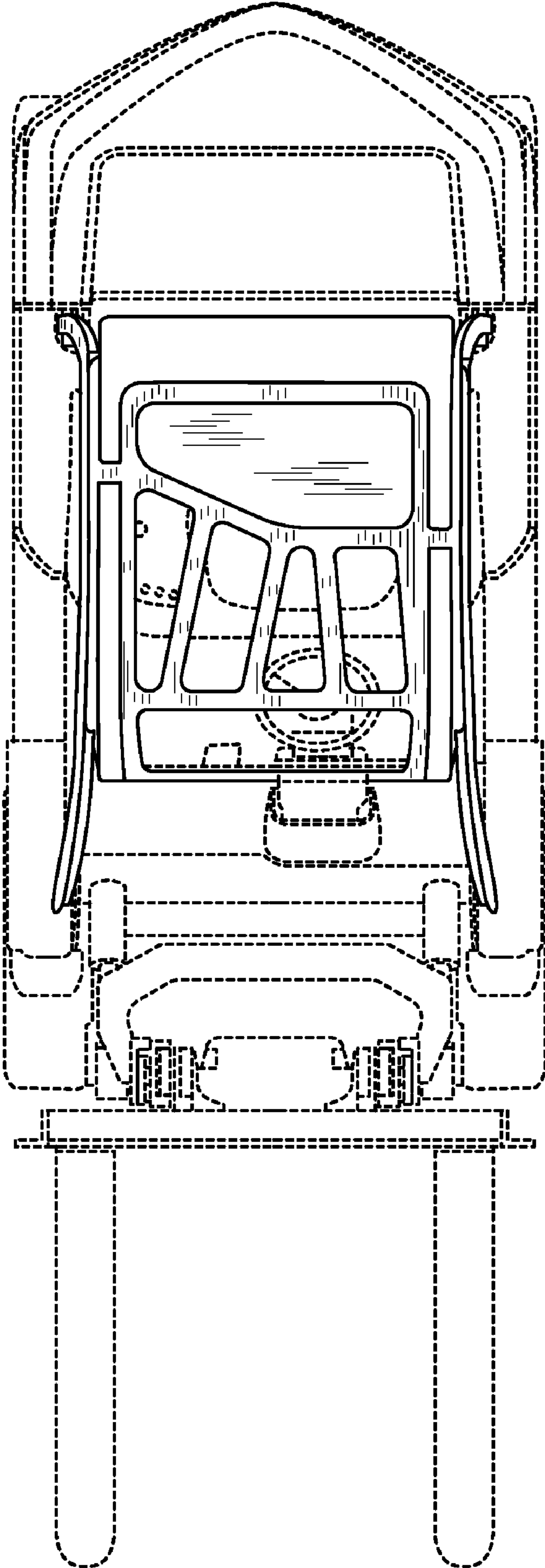




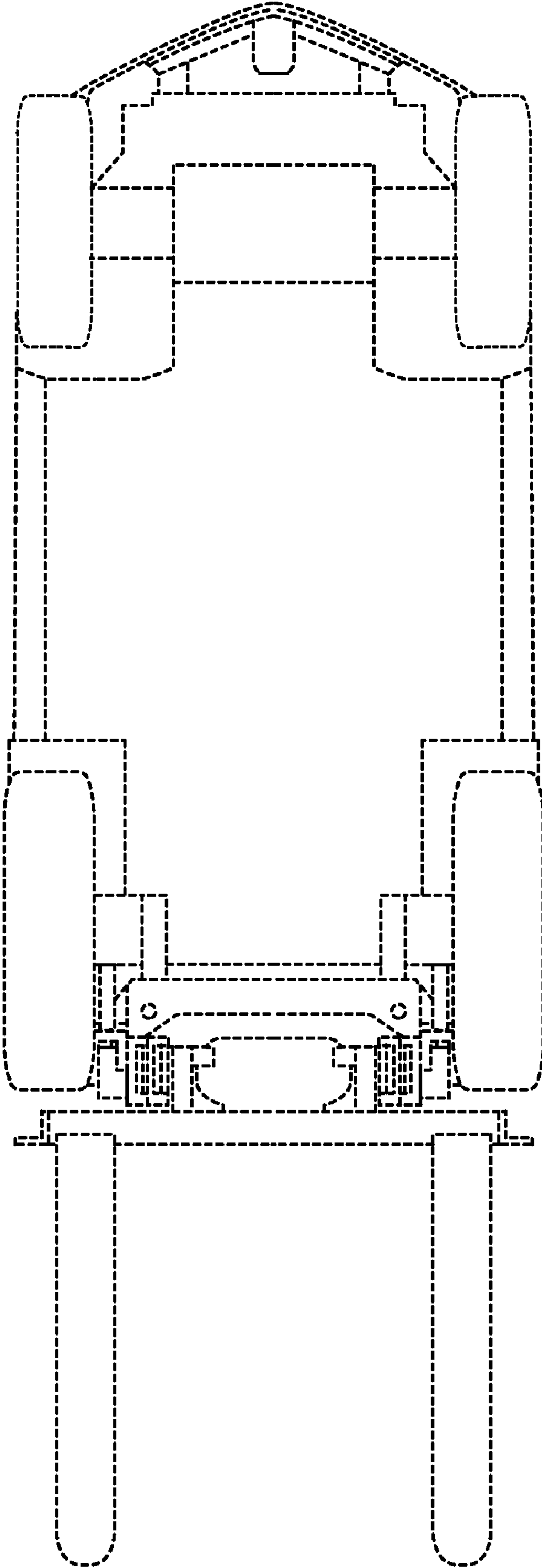
**FIG. 1**



**FIG. 2**

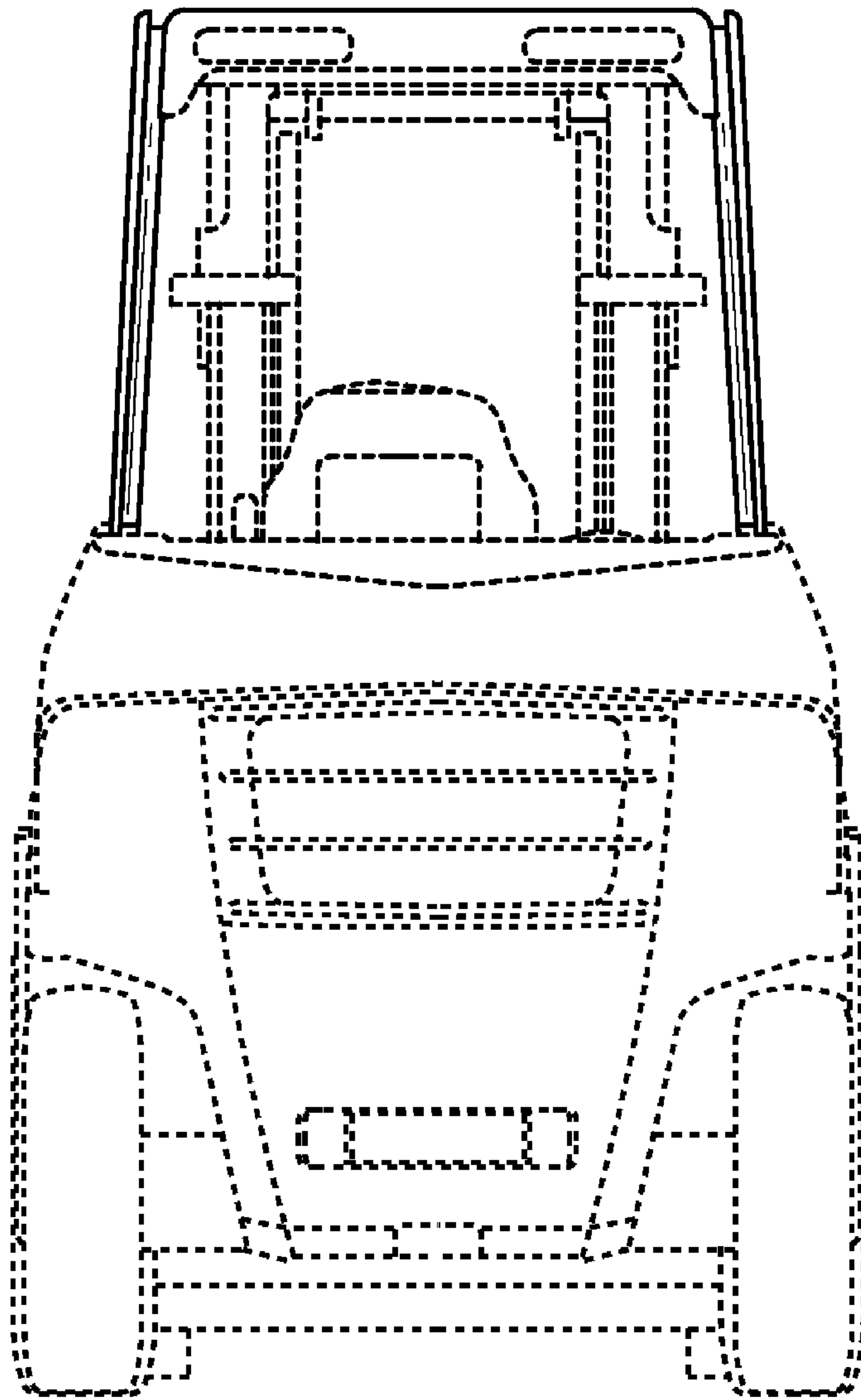


**FIG. 3**

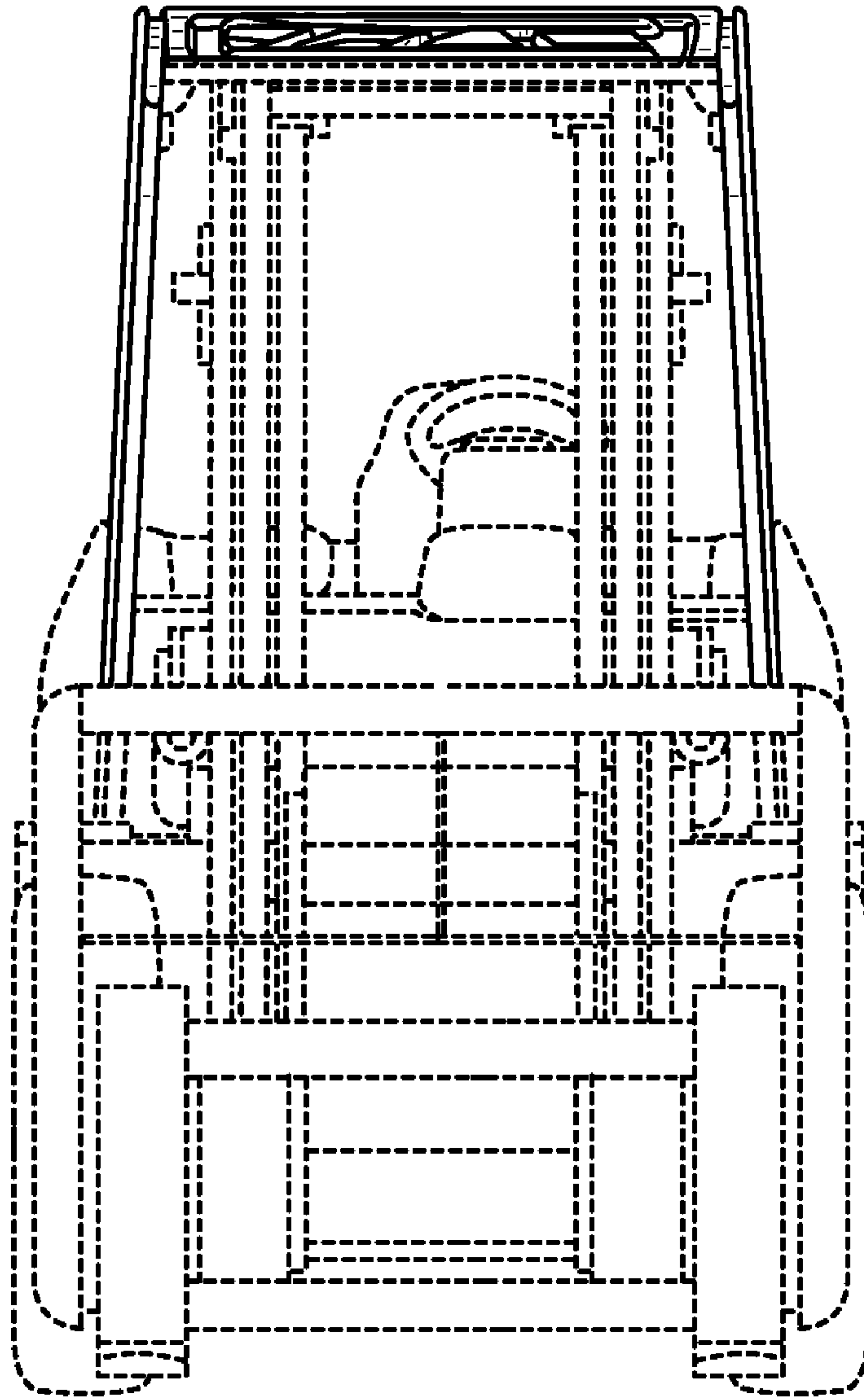


**FIG. 4**





**FIG. 5**



**FIG. 6**

