



US00D594388S

(12) **United States Design Patent**
Sanschagrín et al.

(10) **Patent No.:** **US D594,388 S**
(45) **Date of Patent:** **** Jun. 16, 2009**

(54) **ALL-TERRAIN VEHICLE BODY**
(75) Inventors: **Stephane Sanschagrín**, St-Hyacinthe (CA); **Jean-Philippe Crepeau**, Bromont (CA)
(73) Assignee: **Bombardier Recreational Products Inc.**, Valcourt (CA)
(**) Term: **14 Years**
(21) Appl. No.: **29/278,620**

D523,782 S 6/2006 Lin
D528,044 S 9/2006 Ichikawa et al.
D529,413 S 10/2006 Basset et al.
D529,414 S 10/2006 Wu et al.
D529,840 S 10/2006 Sugawara
D531,550 S 11/2006 Hirano
D532,339 S 11/2006 Hishiki
D534,100 S 12/2006 Kinoshita
D539,705 S 4/2007 Ichikawa et al.
D541,704 S 5/2007 Tanaka et al.
D542,187 S 5/2007 Tanaka et al.
D542,188 S 5/2007 Miwa et al.

(22) Filed: **Apr. 4, 2007**

(51) **LOC (9) Cl.** **12-11**
(52) **U.S. Cl.** **D12/107**
(58) **Field of Classification Search** D12/3,
D12/86, 87, 107, 110; 180/225, 229, 233,
180/311, 312; 296/77.1, 78.1, 180.1, 192,
296/193.01

See application file for complete search history.

(56) **References Cited**

U.S. PATENT DOCUMENTS

D458,562 S 6/2002 Kalhok et al.
D485,212 S 1/2004 Wu
D485,213 S 1/2004 Wu
D503,360 S 3/2005 Crepeau et al.
D505,362 S 5/2005 Nakamura
D511,123 S 11/2005 Lin
D513,396 S 1/2006 Lin
D515,978 S 2/2006 Luh
D515,979 S 2/2006 Luh
D516,466 S 3/2006 Nakazawa et al.
D516,467 S 3/2006 Wu
D516,960 S 3/2006 Luh
D516,961 S 3/2006 Itaya et al.
D517,450 S 3/2006 Wu
D517,951 S 3/2006 Luh
D518,759 S 4/2006 Kettler et al.
D520,914 S 5/2006 Luh
D522,410 S 6/2006 Lin
D522,924 S 6/2006 Yokoyama et al.
D523,781 S 6/2006 Hirano

OTHER PUBLICATIONS

U.S. Appl. No. 29/278,621. Title: Fenders; filed Apr. 4, 2007.
U.S. Appl. No. 29/278,622. Title: Rear Portion of an All-Terrain Vehicle Body; filed Apr. 4, 2007.
U.S. Appl. No. 29/278,618. Title: Portion of an All-Terrain Vehicle Body; filed Apr. 4, 2007.
U.S. Appl. No. 29/278,617. Title: Front Portion of an All-Terrain Vehicle Body; filed Apr. 4, 2007.

Primary Examiner—Cathron C Brooks

Assistant Examiner—Linda Brooks

(74) *Attorney, Agent, or Firm*—Osler, Hoskin & Harcourt LLP

(57) **CLAIM**

The ornamental design for an all-terrain vehicle body, as shown and described.

DESCRIPTION

FIG. 1 is a perspective view from the front and left side of an all-terrain vehicle body according to our design;

FIG. 2 is a top plan view thereof;

FIG. 3 is a front elevational view thereof;

FIG. 4 is a rear elevational view thereof; and,

FIG. 5 is a left side elevational view thereof, a right side elevational view being a mirror image of the left side elevational view.

Throughout the Figures, broken lines showing structure form no part of the claimed design.

1 Claim, 4 Drawing Sheets

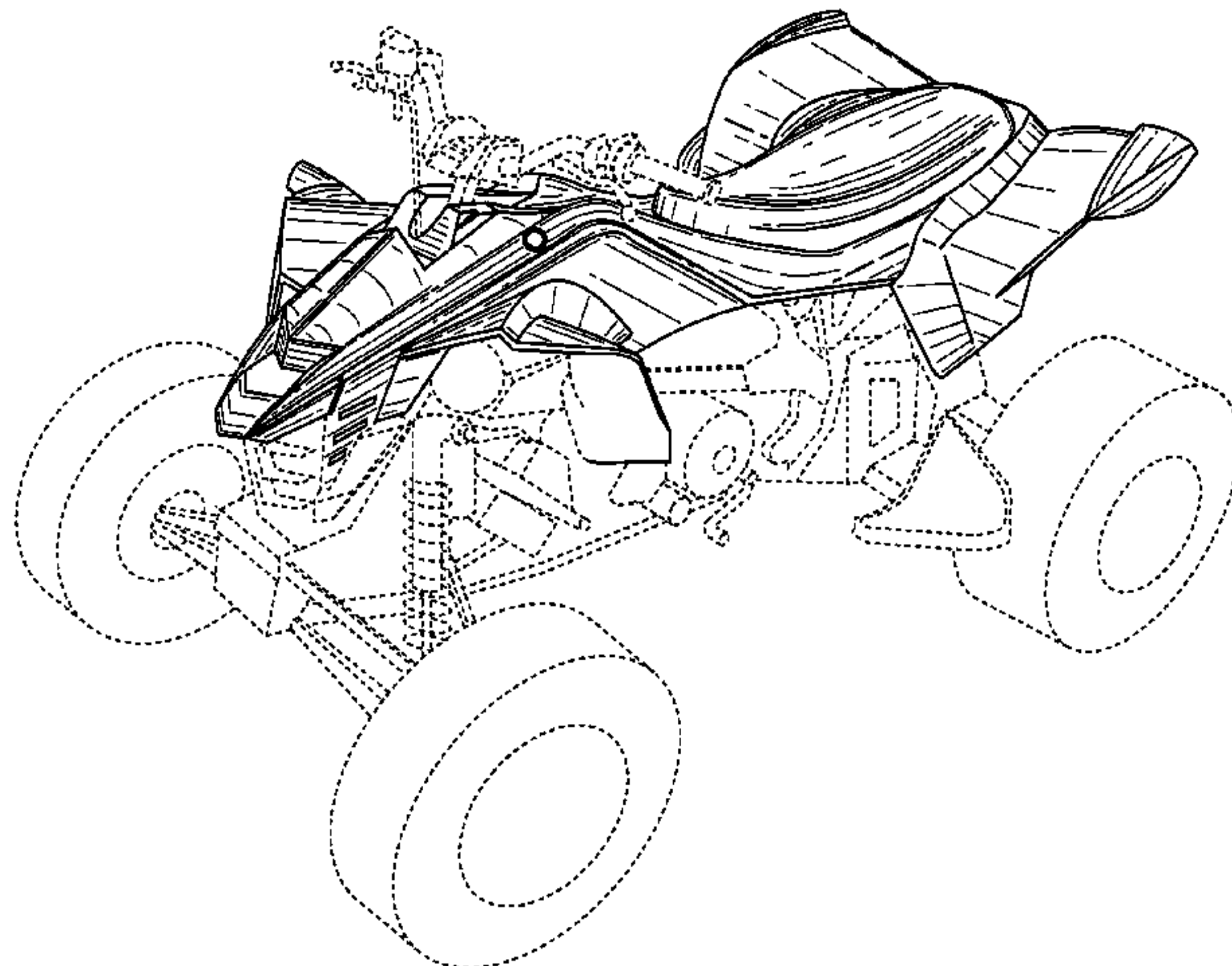

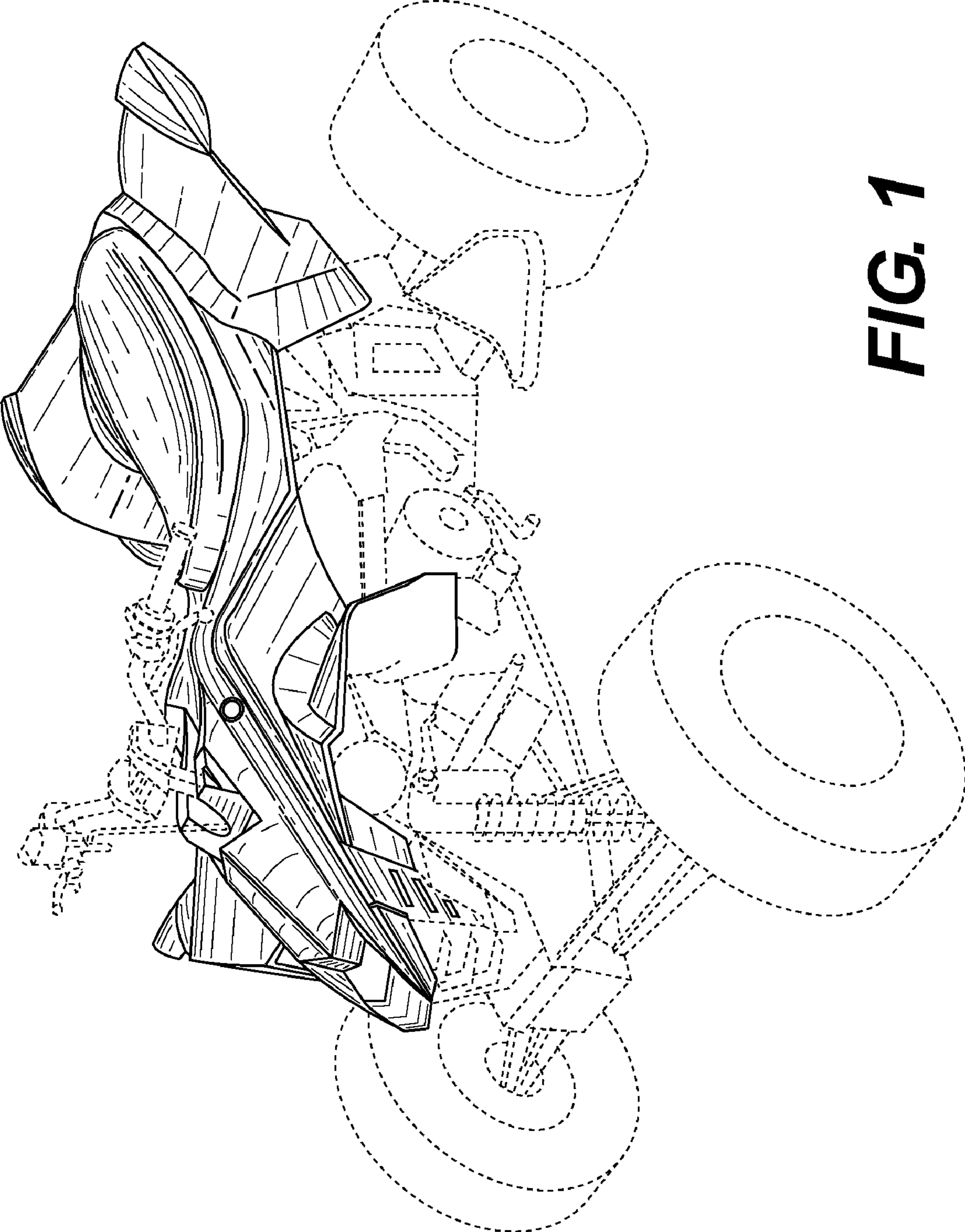

FIG. 1

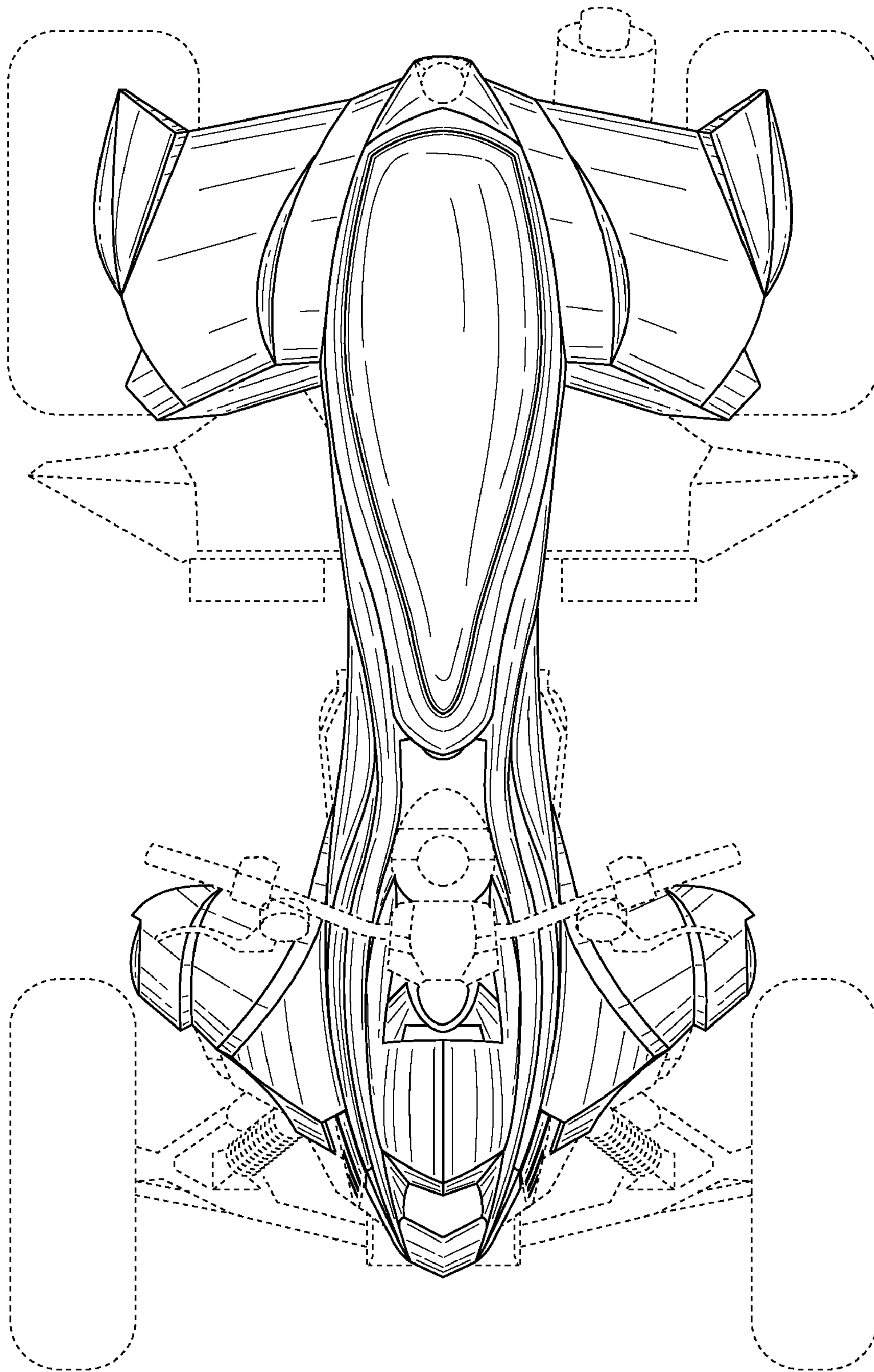
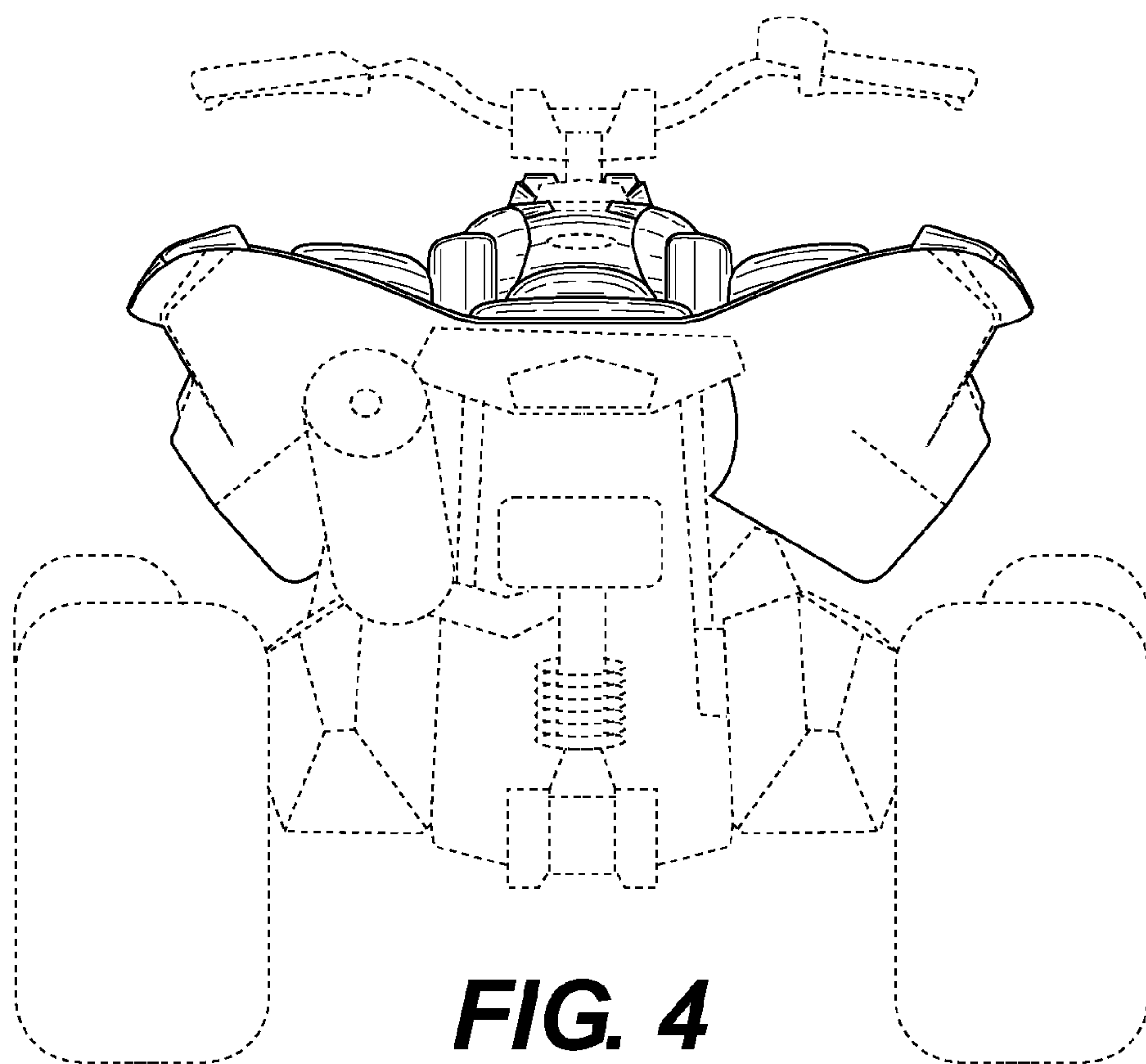
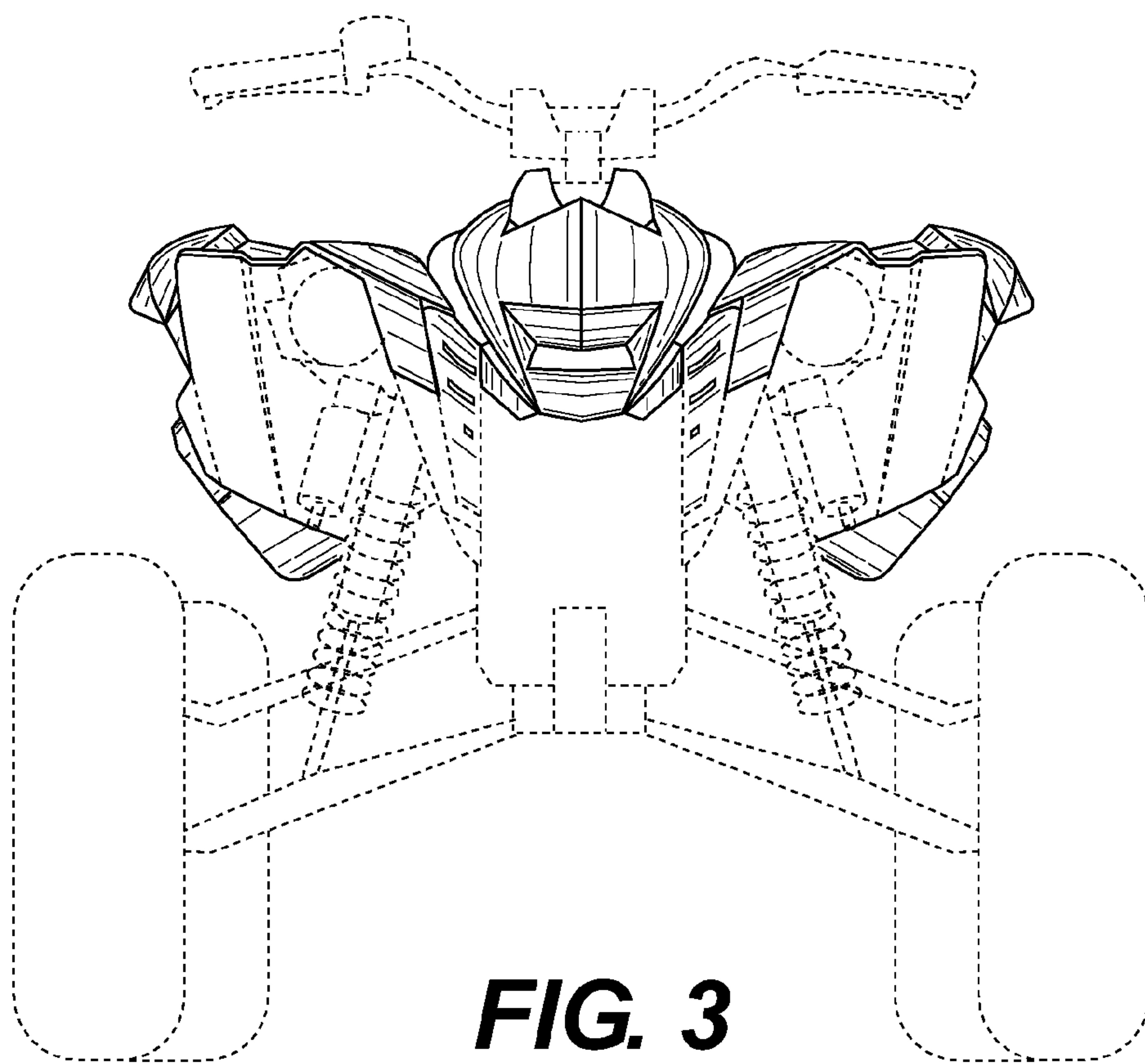

FIG. 2



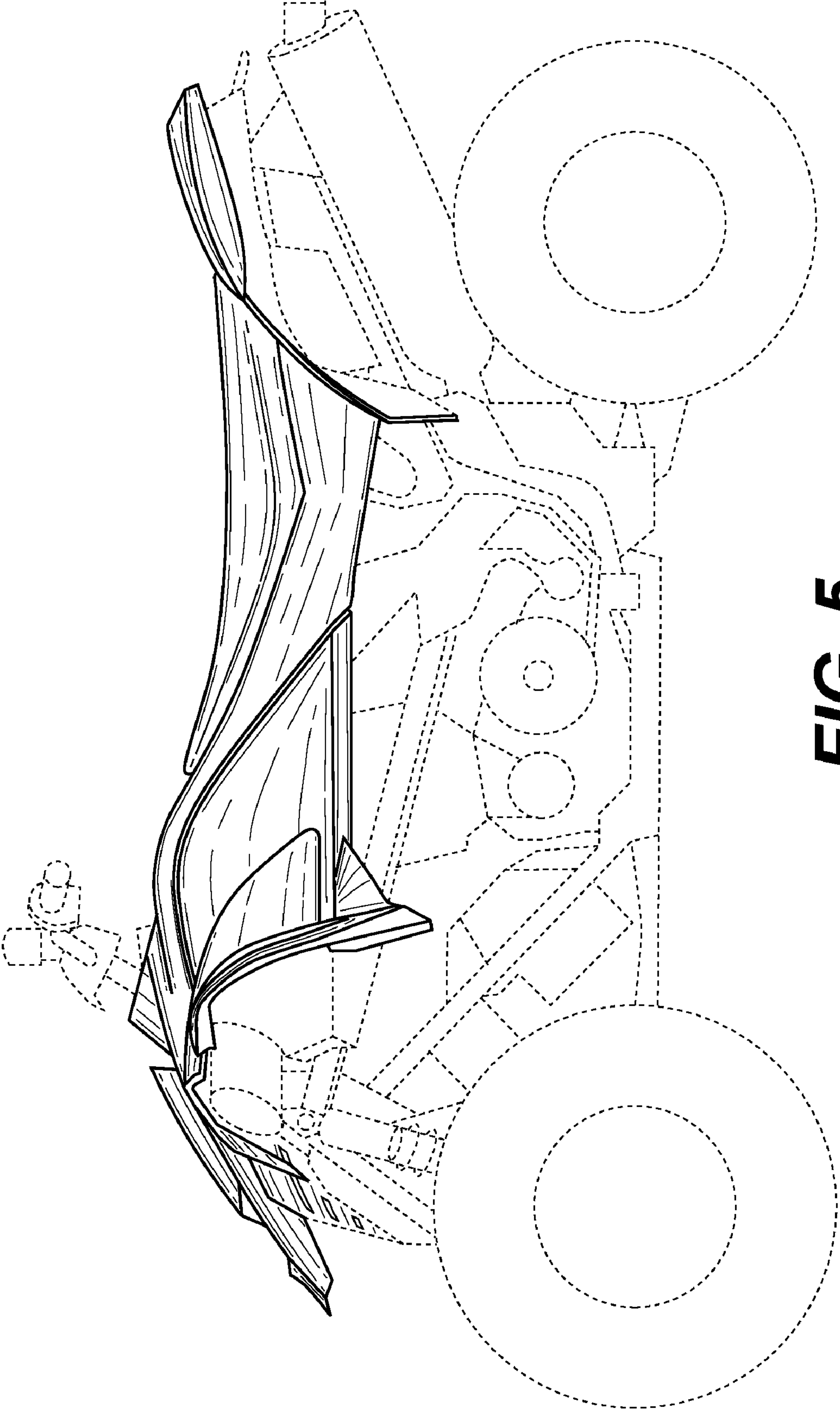

FIG. 5