



US00D594063S

(12) **United States Design Patent**
Blackwell

(10) **Patent No.:** **US D594,063 S**
(45) **Date of Patent:** **** Jun. 9, 2009**

(54) **TOOLBOX FOR DEVELOPMENTAL CURRICULUM**

(76) Inventor: **Devan M. Blackwell**, 120 Red Bank Dr., Mays Landing, NJ (US) 08330

(**) Term: **14 Years**

(21) Appl. No.: **29/284,113**

(22) Filed: **Aug. 31, 2007**

(51) **LOC (9) Cl.** **19-07**

(52) **U.S. Cl.** **D19/59**

(58) **Field of Classification Search** D19/59-64;
434/128, 393, 429, 433; D3/270; D29/102-104;
D9/631, 668; 209/8, 315.8
See application file for complete search history.

(56) **References Cited**

U.S. PATENT DOCUMENTS

D299,765	S	*	2/1989	Lewis et al.	D29/104
D309,753	S	*	8/1990	Kagelmann-Holtz et al.	.	D19/59
D309,754	S	*	8/1990	Kagelmann-Holtz et al.	.	D19/59
D309,914	S	*	8/1990	Kagelmann-Holtz et al.	.	D19/59
D309,915	S	*	8/1990	Kagelmann-Holtz et al.	.	D19/59
D336,660	S	*	6/1993	Dial	D19/64
D344,544	S	*	2/1994	Dial	D19/64
D370,308	S	*	5/1996	Nilsson	D29/102
D371,224	S	*	6/1996	Carlson et al.	D29/102
D383,876	S	*	9/1997	Pacheco	D29/103
D481,494	S	*	10/2003	Ho	D29/104
D566,767	S	*	4/2008	Urdarevik	D19/62
D575,457	S	*	8/2008	Ho et al.	D29/102

* cited by examiner

Primary Examiner—T. Chase Nelson

Assistant Examiner—Mark Cavanna

(74) *Attorney, Agent, or Firm*—Dann, Dorfman, Herrell and Skillman; Henry H. Skillman

(57) **CLAIM**

The ornamental design for toolbox for developmental curriculum, as shown and described.

DESCRIPTION

FIG. 1 is a perspective view of a toolbox for developmental curriculum showing my new design;

FIG. 2 is a top plan thereof;

FIG. 4 is a right side elevation thereof with the left side elevation being a mirror image;

FIG. 3 is a rear elevation thereof;

FIG. 5 is a front elevation thereof;

FIG. 6 is a bottom plan view thereof;

FIG. 7 is a perspective view of a toolbox for developmental curriculum shown in FIG. 1, with the cover open; and,

FIG. 8 is a perspective view of a toolbox for developmental curriculum shown in FIG. 1, with the cover open and in condition of use.

The broken line showing of cubes in FIG. 8 is included for the purpose of illustrating environment and forms no part of the claimed design.

1 Claim, 4 Drawing Sheets

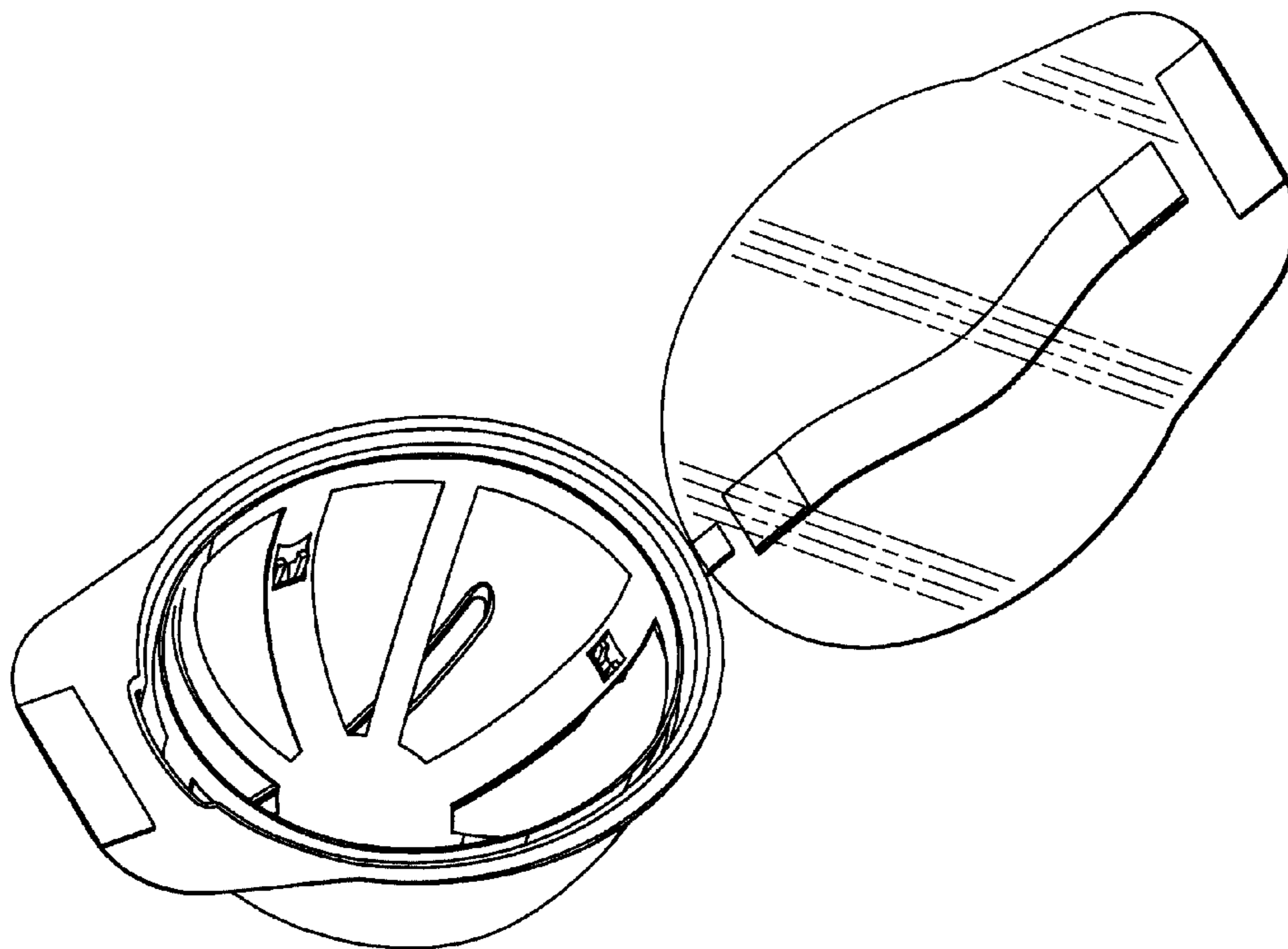

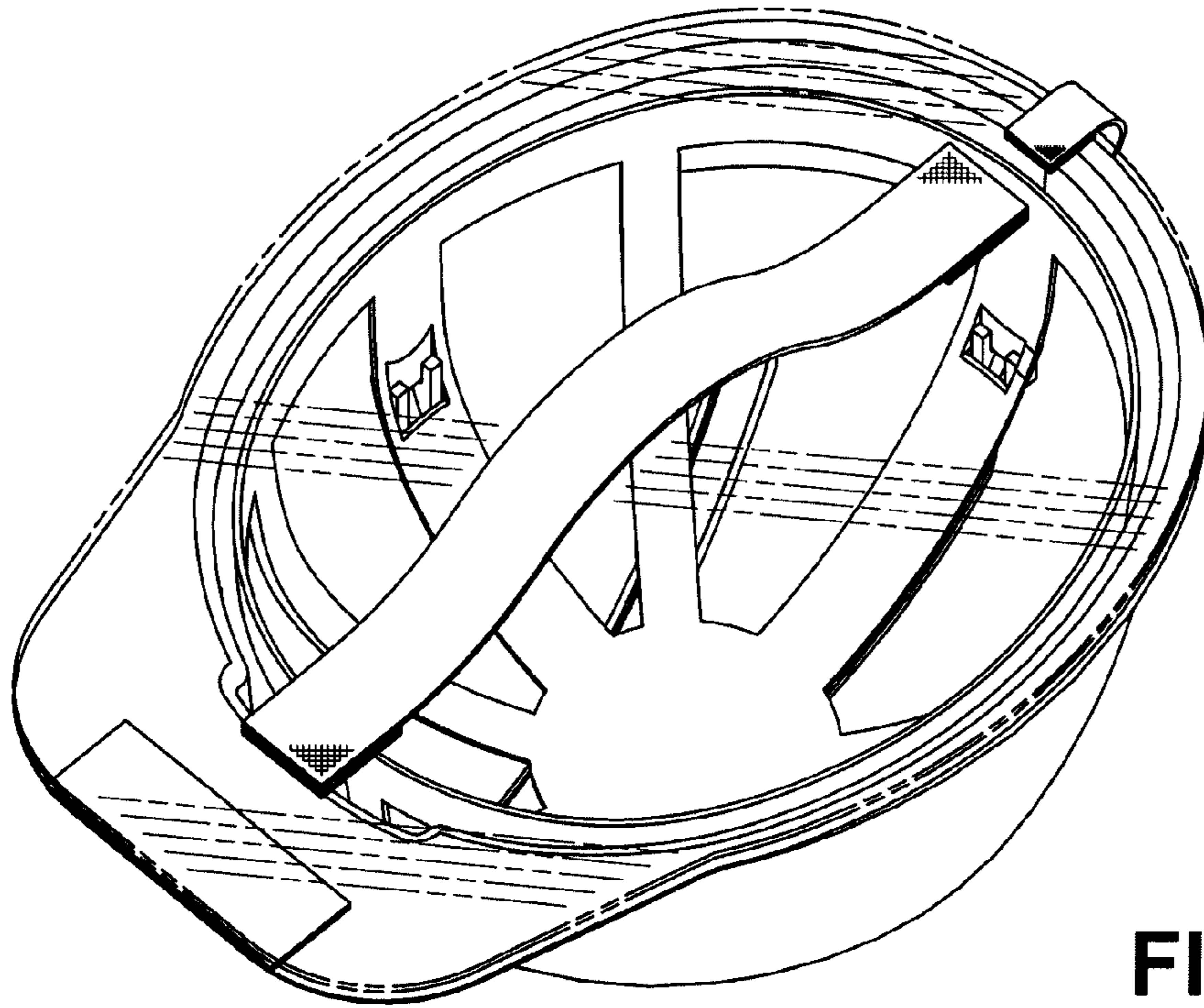

FIG. 1

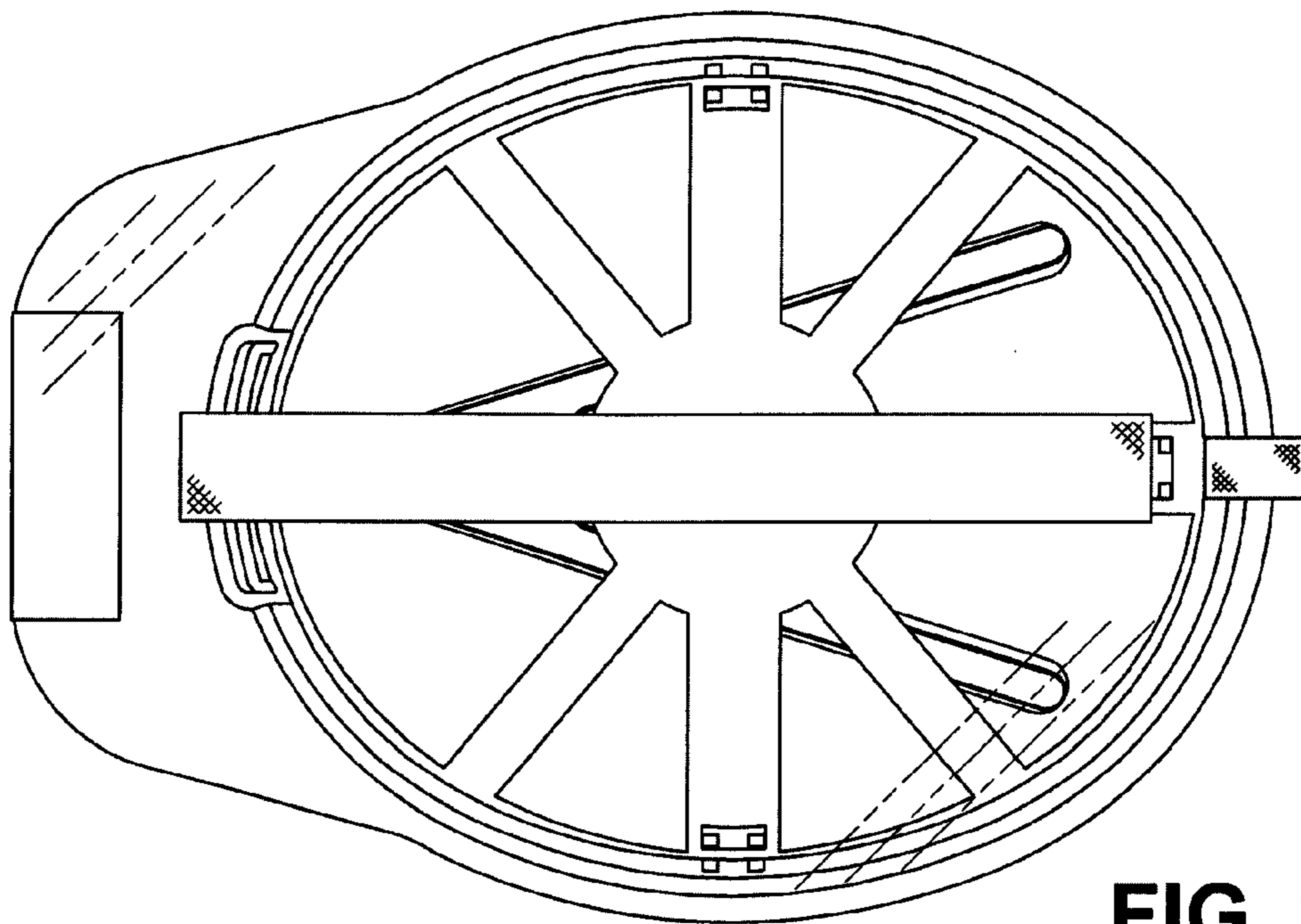

FIG. 2

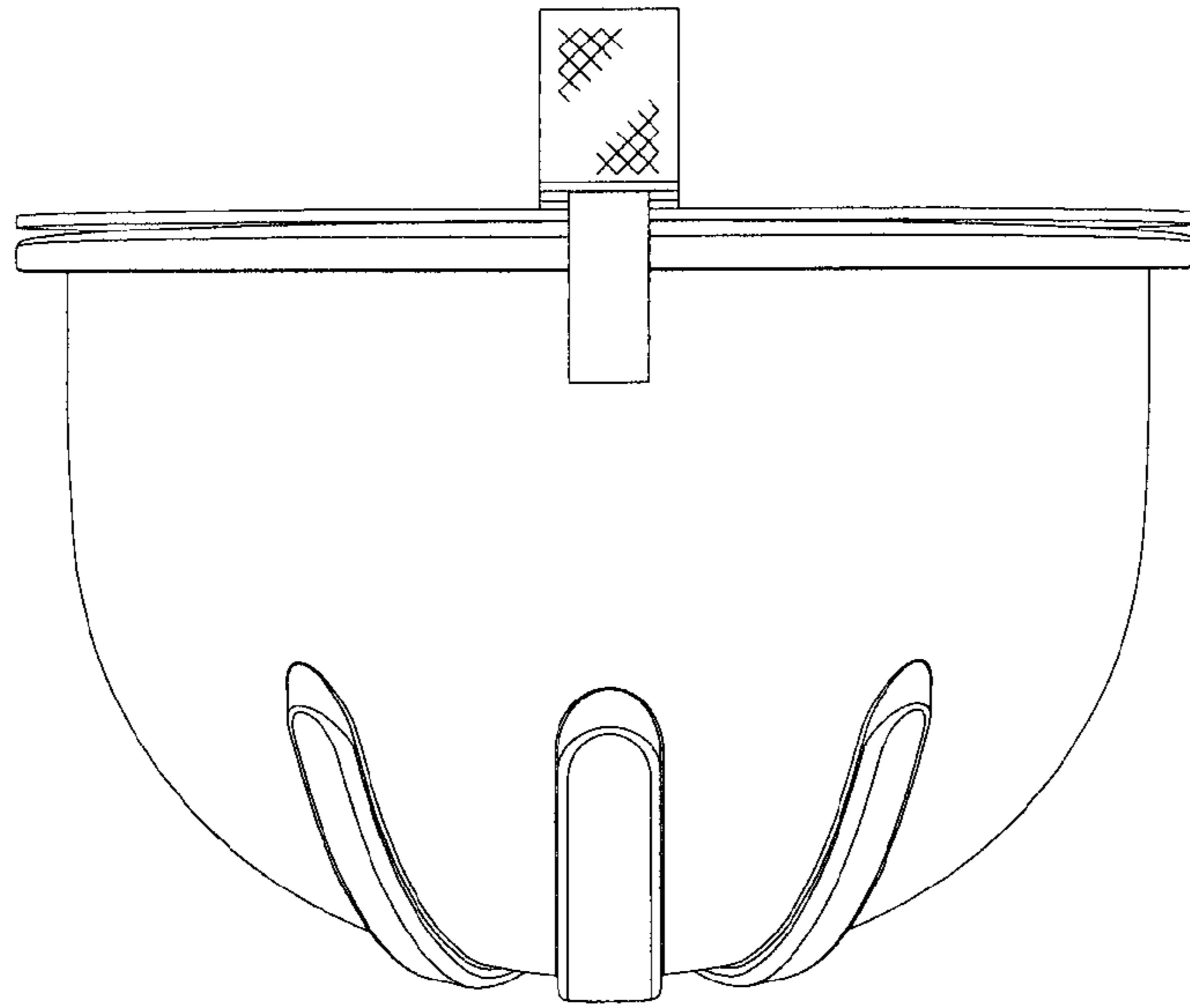

FIG. 3

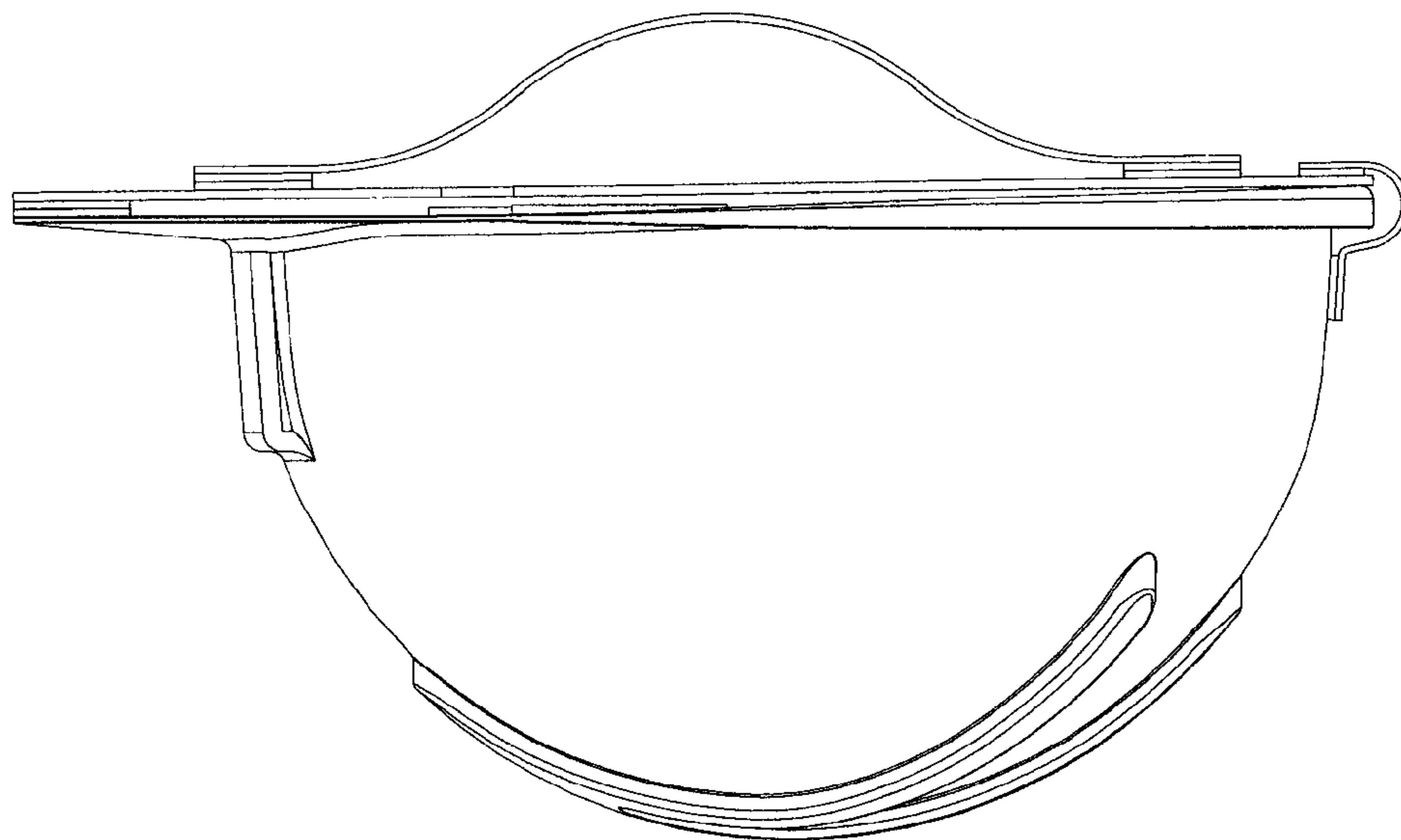

FIG. 4

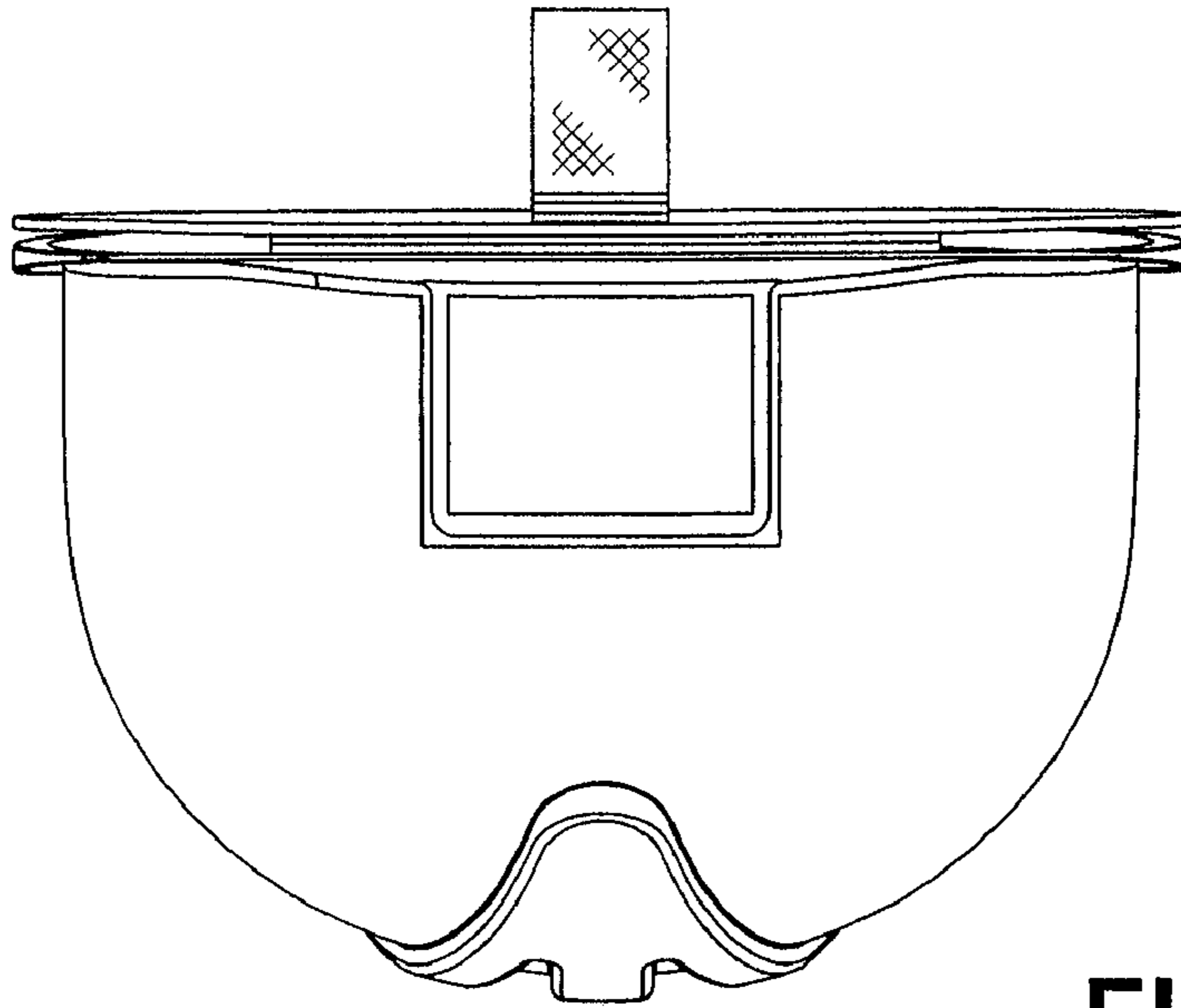

FIG. 5

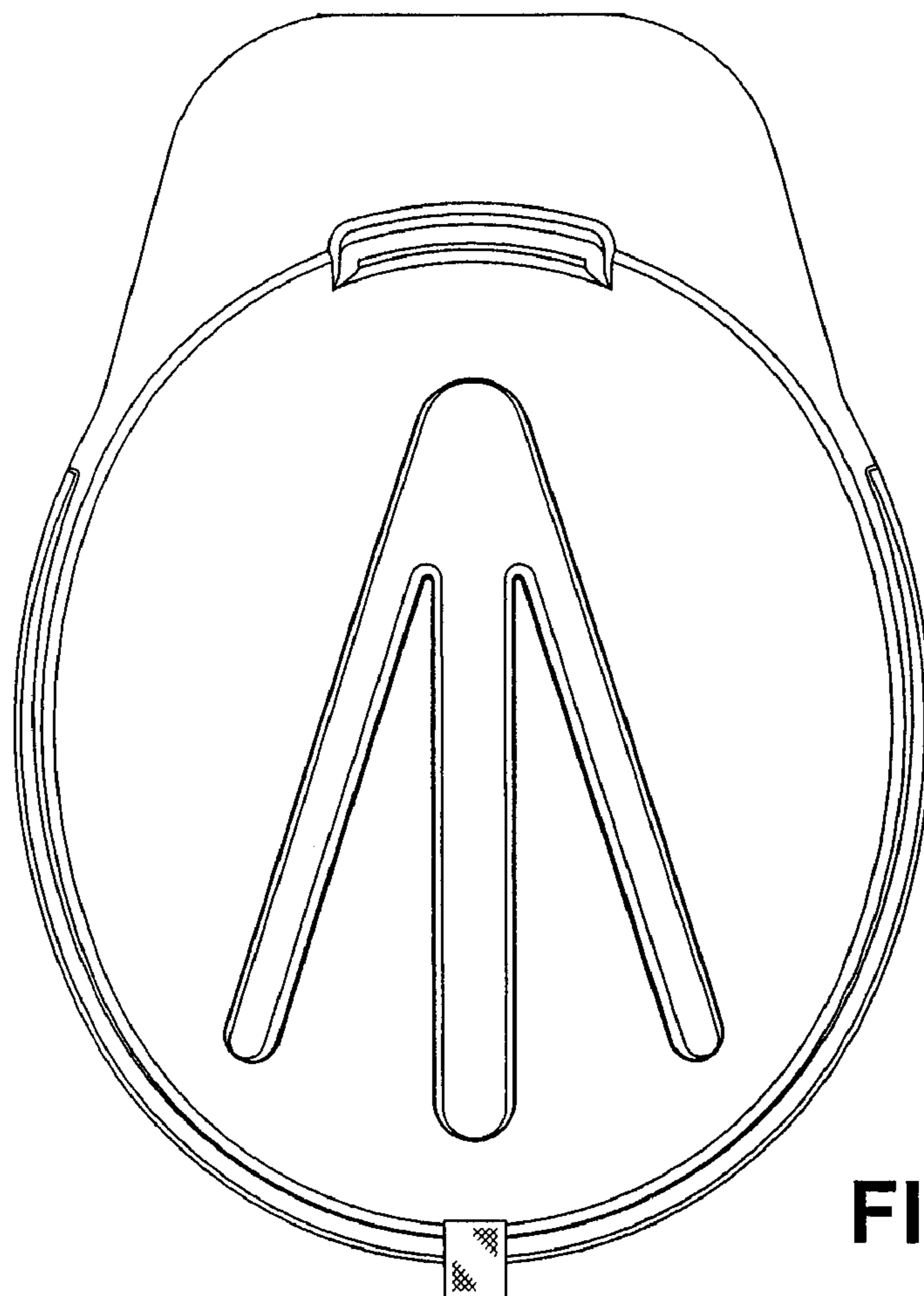

FIG. 6

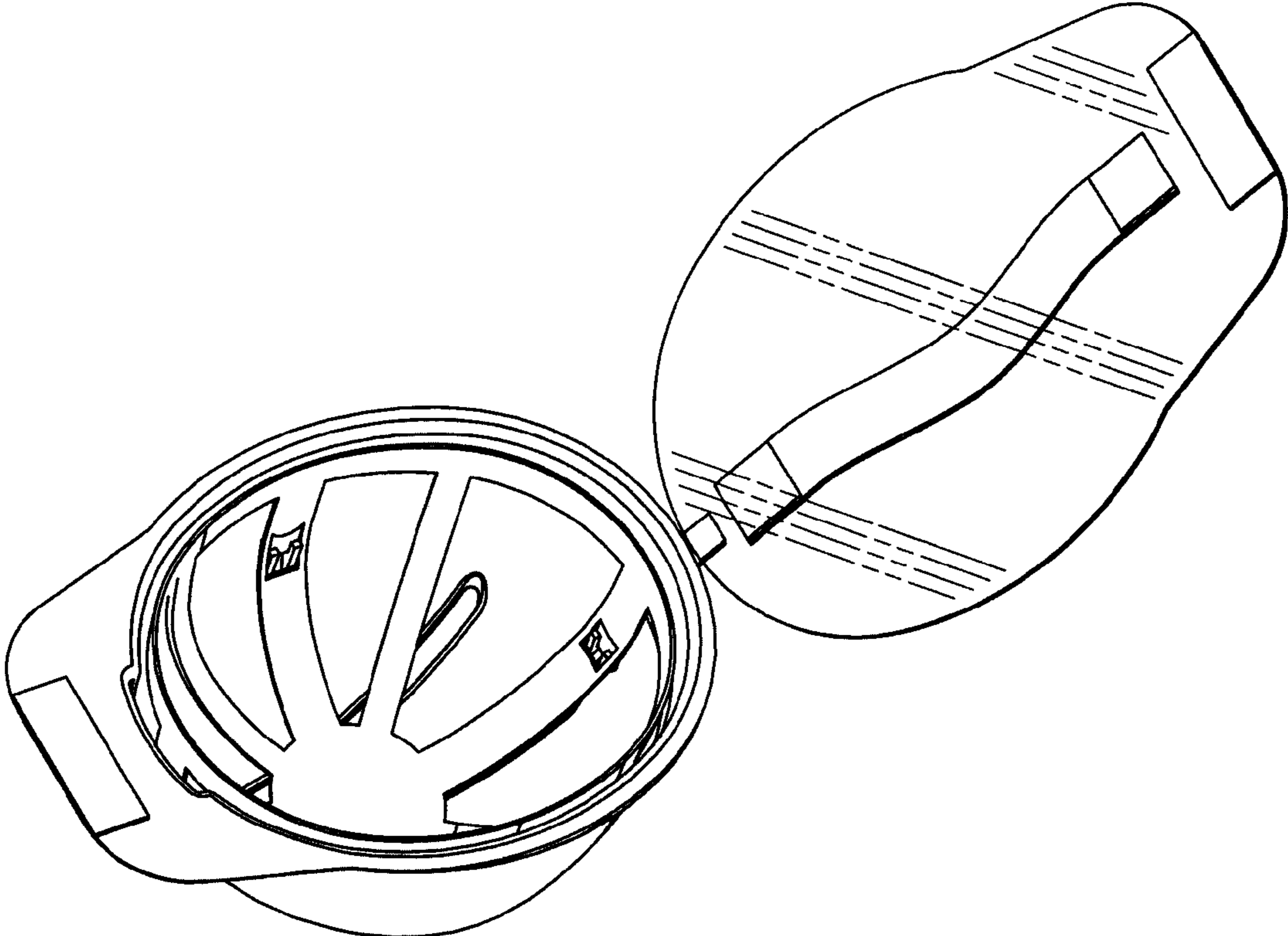

FIG. 7

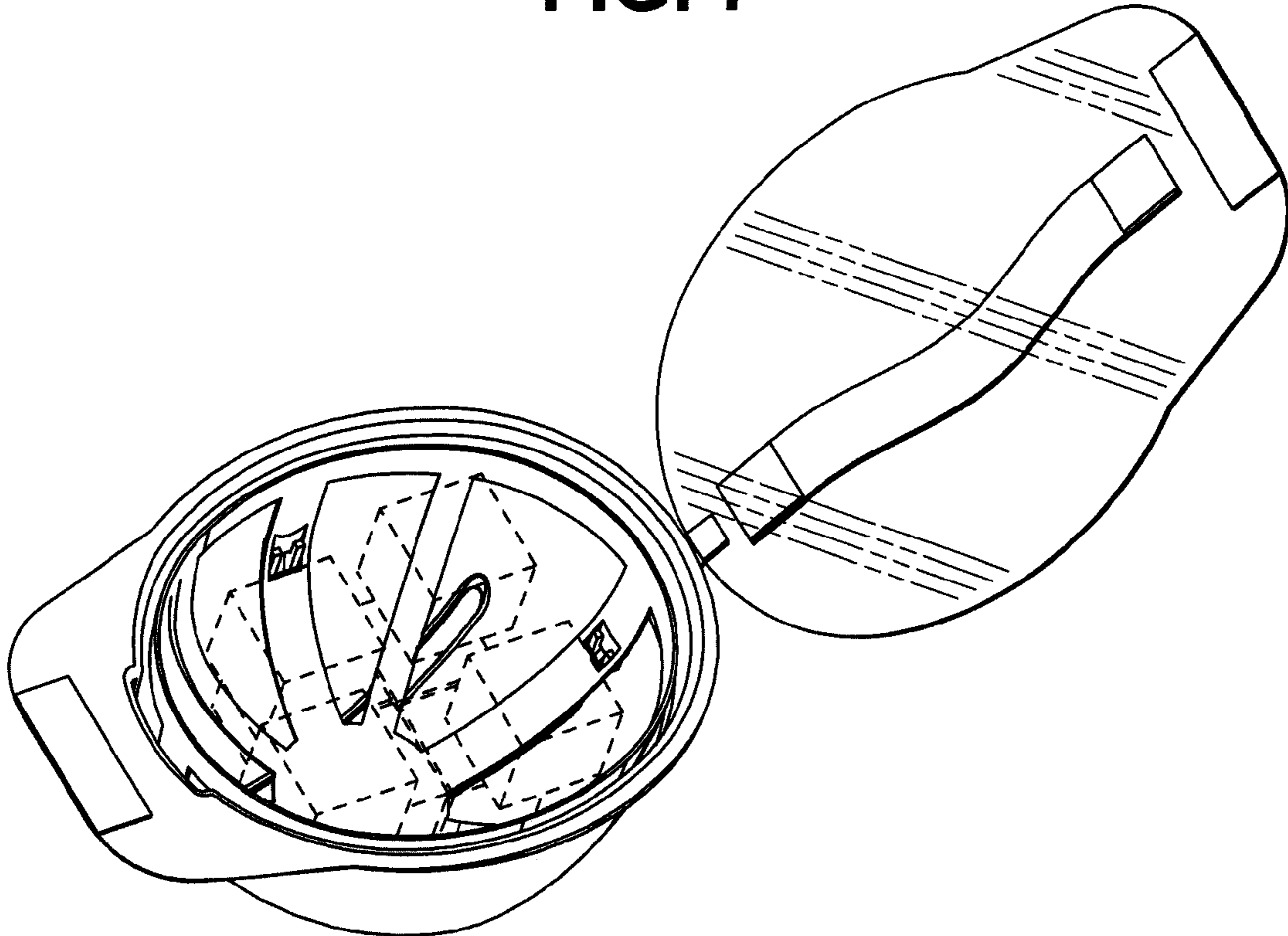

FIG. 8