



US00D593911S

(12) **United States Design Patent**  
**Egan et al.**

(10) **Patent No.:** **US D593,911 S**  
(45) **Date of Patent:** **\*\* Jun. 9, 2009**

(54) **MOTORCYCLE FOOTPEG**

(75) Inventors: **Craig P. Egan**, Peterborough (CA);  
**Christopher D. Lindloff**, New  
Richmond, WI (US)

(73) Assignee: **Kuraykyn Holdings, Inc.**, Somerset, WI  
(US)

(\*\*) Term: **14 Years**

(21) Appl. No.: **29/294,666**

(22) Filed: **Jan. 22, 2008**

(51) **LOC (9) Cl.** ..... **12-11**

(52) **U.S. Cl.** ..... **D12/114**

(58) **Field of Classification Search** ..... D12/110,  
D12/203, 125, 114, 122; 74/564, 478, 512,  
74/560, 473.16, 594.4, 594.7, 478.5; 280/288.4,  
280/291, 304.4, 163, 169, 164.1; 180/219,  
180/230; 296/75

See application file for complete search history.

(56) **References Cited**

**U.S. PATENT DOCUMENTS**

D484,830 S \* 1/2004 Price ..... D12/114  
D494,515 S \* 8/2004 DeBerti ..... D12/174  
D534,408 S \* 1/2007 Sultan ..... D8/70

**OTHER PUBLICATIONS**

J & P Cycles® Keeping the World on 2 Wheels® 2006 Metric Cruiser  
& Sportbike Catalog, flame footpegs on p. 327.\*

\* cited by examiner

*Primary Examiner*—Cathron C Brooks

*Assistant Examiner*—Linda Brooks

(74) *Attorney, Agent, or Firm*—Dicke, Billig & Czaja, PLLC

(57) **CLAIM**

The ornamental design for a motorcycle footpeg, as shown  
and described.

**DESCRIPTION**

FIG. 1 is a top perspective view of a motorcycle footpeg of the  
present invention.

FIG. 2 is a top plan view thereof.

FIG. 3 is a bottom plan view thereof.

FIG. 4 is a side elevation view thereof.

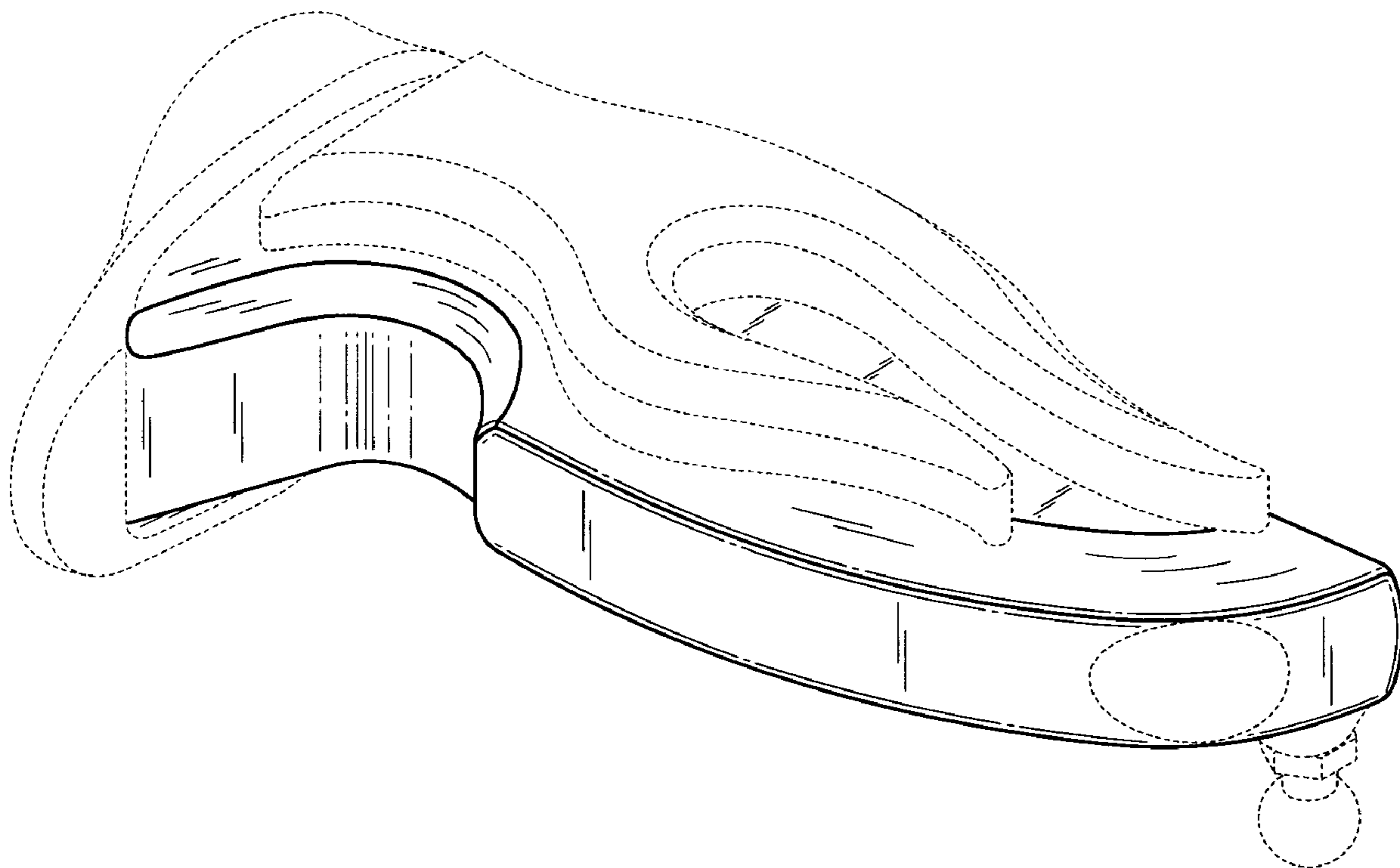
FIG. 5 is the opposite side elevation view thereof.

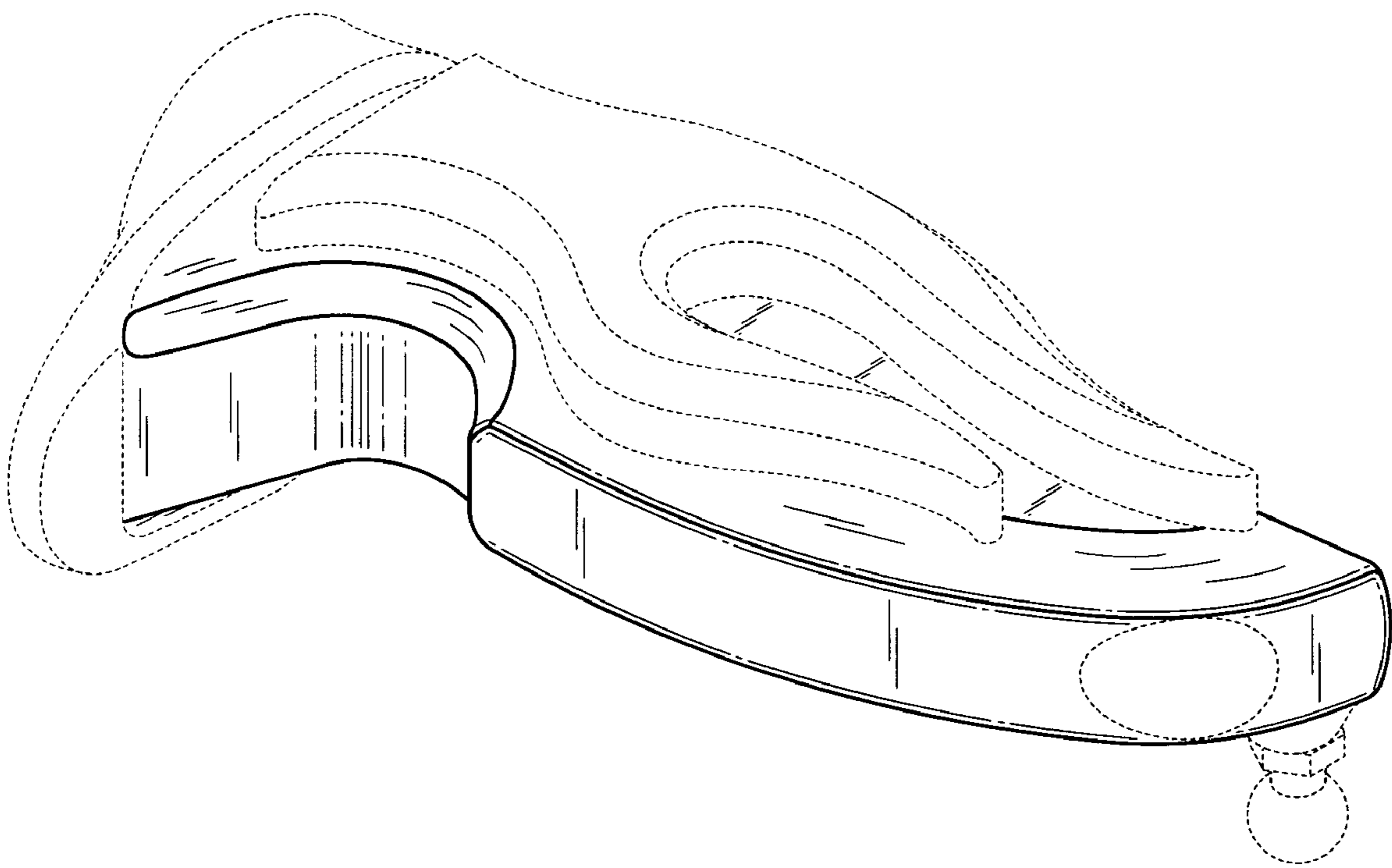
FIG. 6 is an end elevation view thereof; and,

FIG. 7 is the opposite end elevation view thereof.

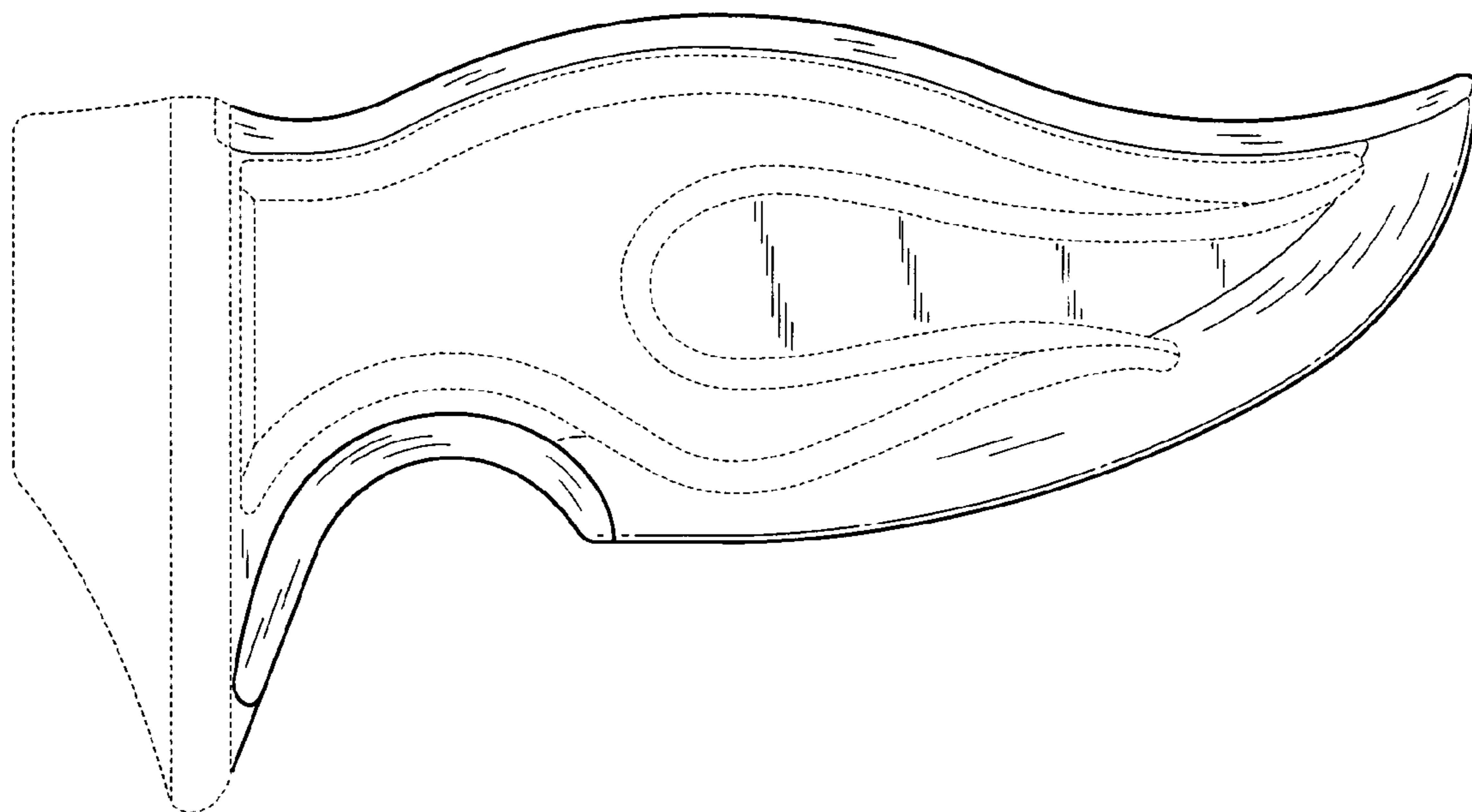
Those portions of the motorcycle footpeg shown in broken  
lines form no part of the claimed design.

**1 Claim, 4 Drawing Sheets**

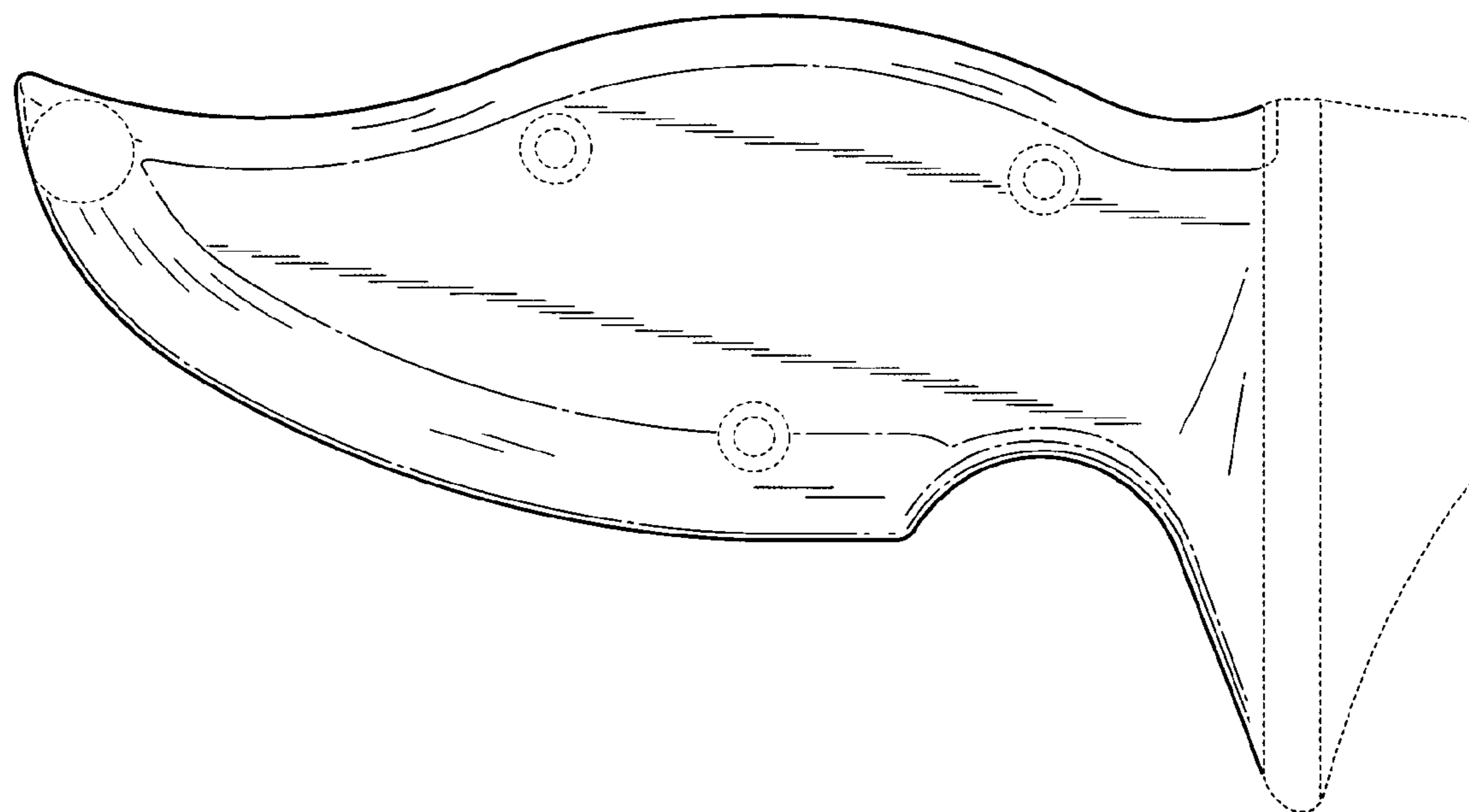




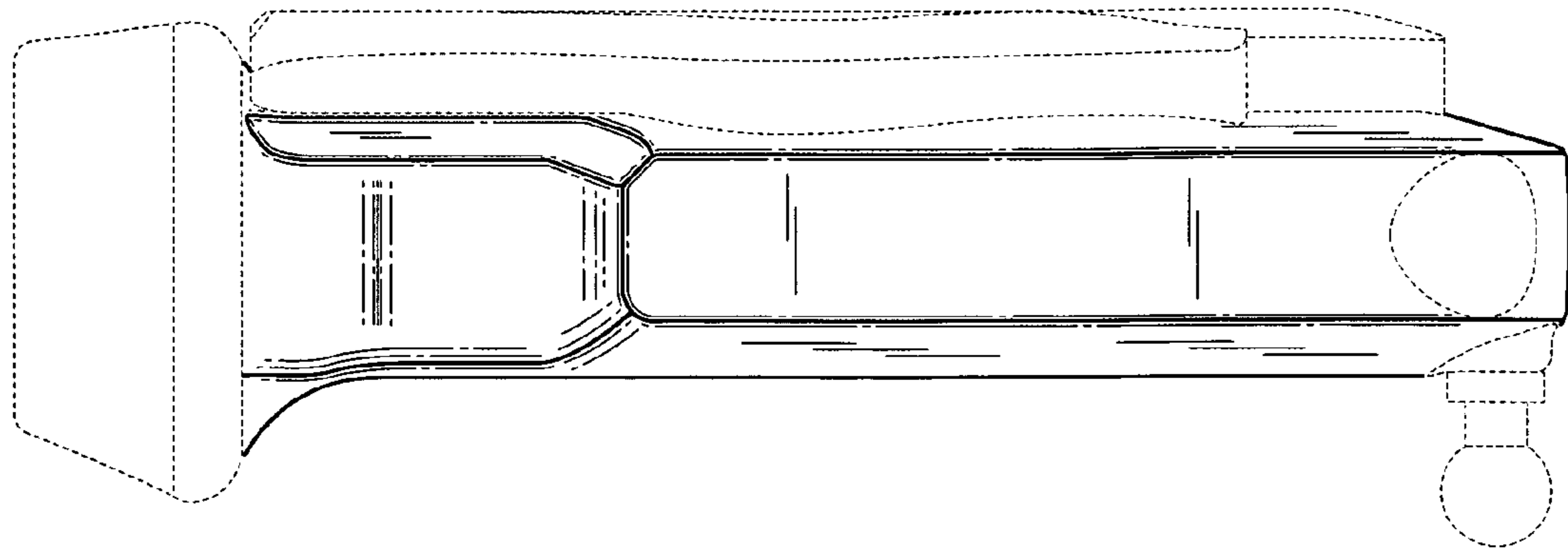
**Fig. 1**



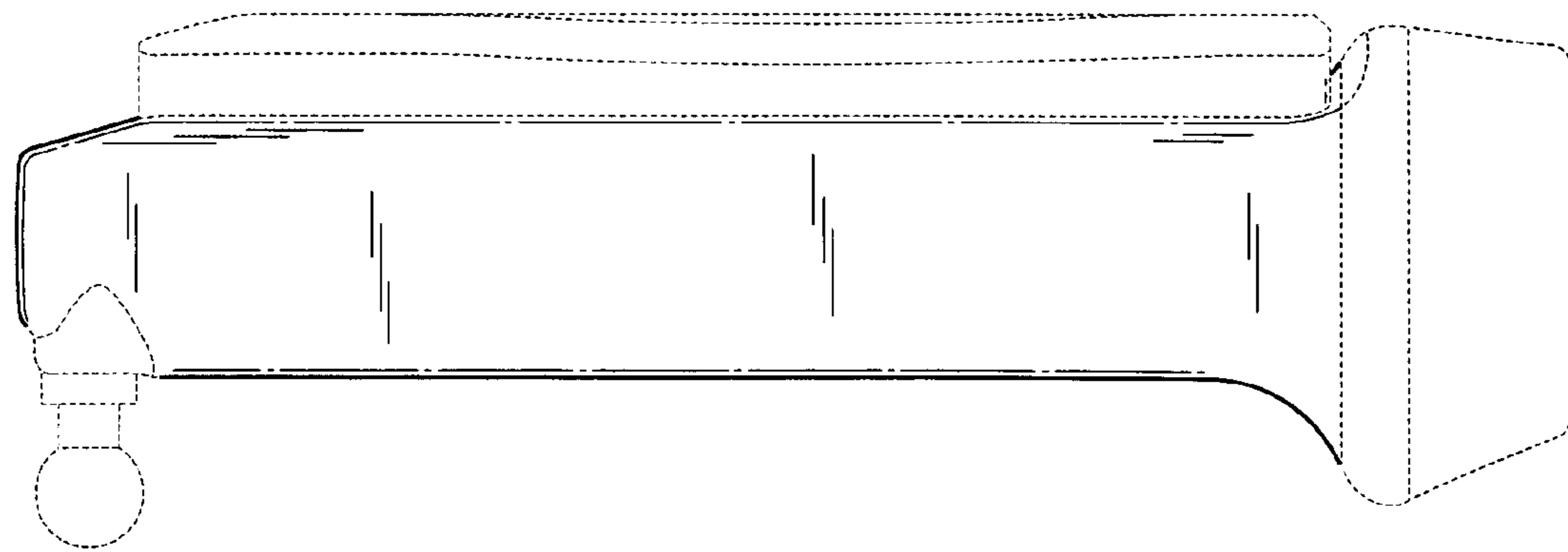
**Fig. 2**



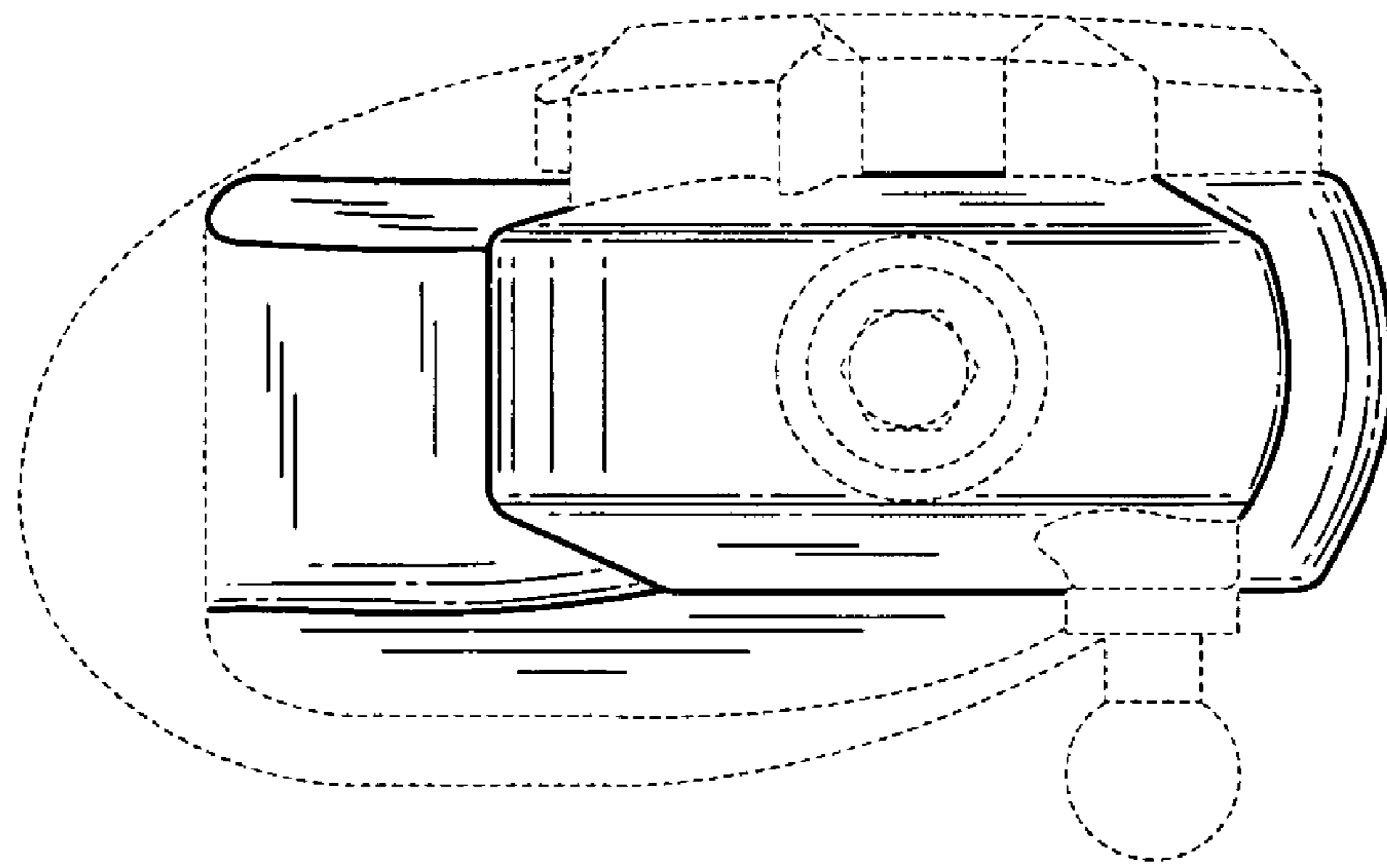
**Fig. 3**



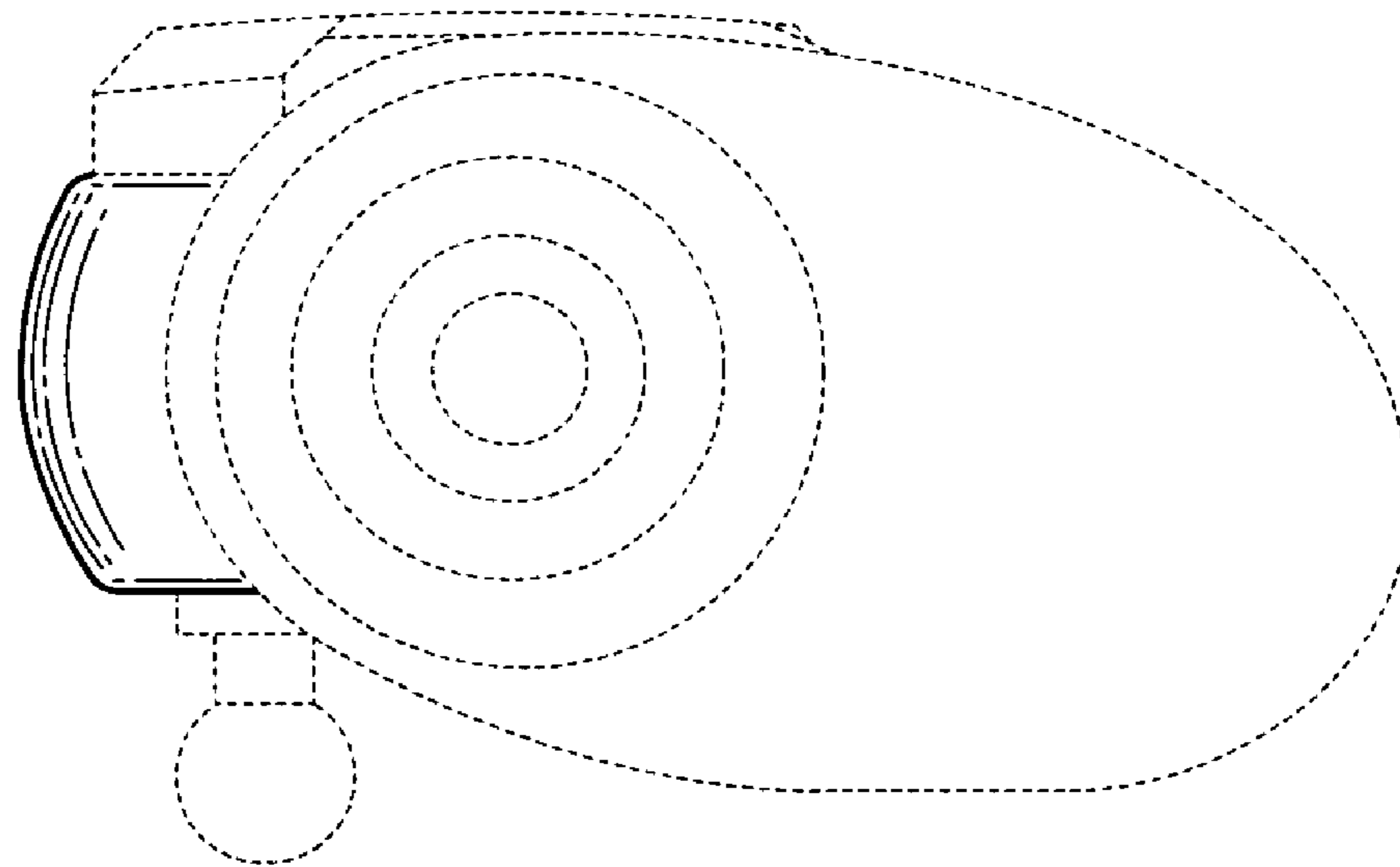
**Fig. 4**



**Fig. 5**



**Fig. 6**



**Fig. 7**