



US00D593830S

(12) **United States Design Patent**  
**Van Wambeke**

(10) **Patent No.:** **US D593,830 S**  
(45) **Date of Patent:** **\*\* Jun. 9, 2009**

(54) **DRIVER**

(75) Inventor: **Weston J. Van Wambeke**, Towson, MD (US)

(73) Assignee: **Black & Decker Inc.**, Newark, DE (US)

(\*\*) Term: **14 Years**

(21) Appl. No.: **29/283,787**

(22) Filed: **Aug. 23, 2007**

(51) **LOC (9) Cl.** ..... **08-05**

(52) **U.S. Cl.** ..... **D8/68**

(58) **Field of Classification Search** ..... D8/14.1,  
D8/61, 62, 63, 64, 65, 66, 67, 68, 69, 70;  
81/57.11, 429, 454, 455, 456, 469, 489; 173/13,  
173/104, 114, 168, 169, 170, 171, 178, 201,  
173/211, 213, 217; 408/20, 124, 125, 234,  
408/241 R; 451/358; 310/50; 227/8, 113,  
227/114, 120, 130, 136, 142

See application file for complete search history.

(56) **References Cited**

**U.S. PATENT DOCUMENTS**

D353,526 S	12/1994	Hoshino	
5,372,206 A *	12/1994	Sasaki et al.	173/178
D394,995 S *	6/1998	Cooper	D8/68
D400,074 S *	10/1998	Cooper	D8/68
D403,565 S	1/1999	Chung	
5,984,022 A *	11/1999	Harman et al.	81/57.11
D467,482 S *	12/2002	Kunz et al.	D8/68
D467,781 S *	12/2002	Kunz et al.	D8/68
D470,378 S *	2/2003	Chunn et al.	D8/68
D474,953 S *	5/2003	Santarsiero et al.	D8/68
6,702,530 B2 *	3/2004	Bennage et al.	408/241 R
D490,677 S *	6/2004	Chung et al.	D8/68
D496,573 S *	9/2004	Cooper	D8/68
D498,400 S	11/2004	Wu	
D507,952 S	8/2005	Wu	
D514,909 S *	2/2006	Bosch	D8/68
D521,338 S *	5/2006	Wai	D8/68

D526,178 S *	8/2006	Alias	D8/68
D533,040 S *	12/2006	Schoen	D8/68
D534,403 S *	1/2007	Concari	D8/68
D535,860 S *	1/2007	Cooper	D8/68
D539,110 S *	3/2007	Okuda	D8/68
D557,581 S *	12/2007	Stratford	D8/68
D565,375 S *	4/2008	Shi	D8/68
D566,506 S *	4/2008	Aglassinger	D8/68
D576,006 S *	9/2008	Houghton	D8/68
D581,762 S *	12/2008	Aglassinger	D8/68
D582,235 S *	12/2008	Murray	D8/68
D582,740 S *	12/2008	Weinberg et al.	D8/68
2003/0070822 A1 *	4/2003	Kanzaki et al.	173/217
2003/0165366 A1 *	9/2003	Bennage et al.	408/241 R
2005/0257945 A1 *	11/2005	Justis et al.	173/170
2007/0256847 A1 *	11/2007	Wan et al.	173/217

\* cited by examiner

*Primary Examiner*—T. Chase Nelson

*Assistant Examiner*—Karen Acker

(74) *Attorney, Agent, or Firm*—Bruce S. Shapiro; John Yun; Wesley W. Muller

(57) **CLAIM**

The ornamental design for a driver, as shown and described.

**DESCRIPTION**

FIG. 1 is a right/front perspective view of a driver.

FIG. 2 is a front view thereof.

FIG. 3 is a rear view thereof.

FIG. 4 is a right side view thereof.

FIG. 5 is a left side view thereof.

FIG. 6 is a top view thereof.

FIG. 7 is a bottom view thereof; and,

FIG. 8 is a left/rear perspective view thereof.

The broken lines are included for purposes of illustrating environmental structure. These broken lines and the structure they depict form no part of the claimed design.

**1 Claim, 7 Drawing Sheets**

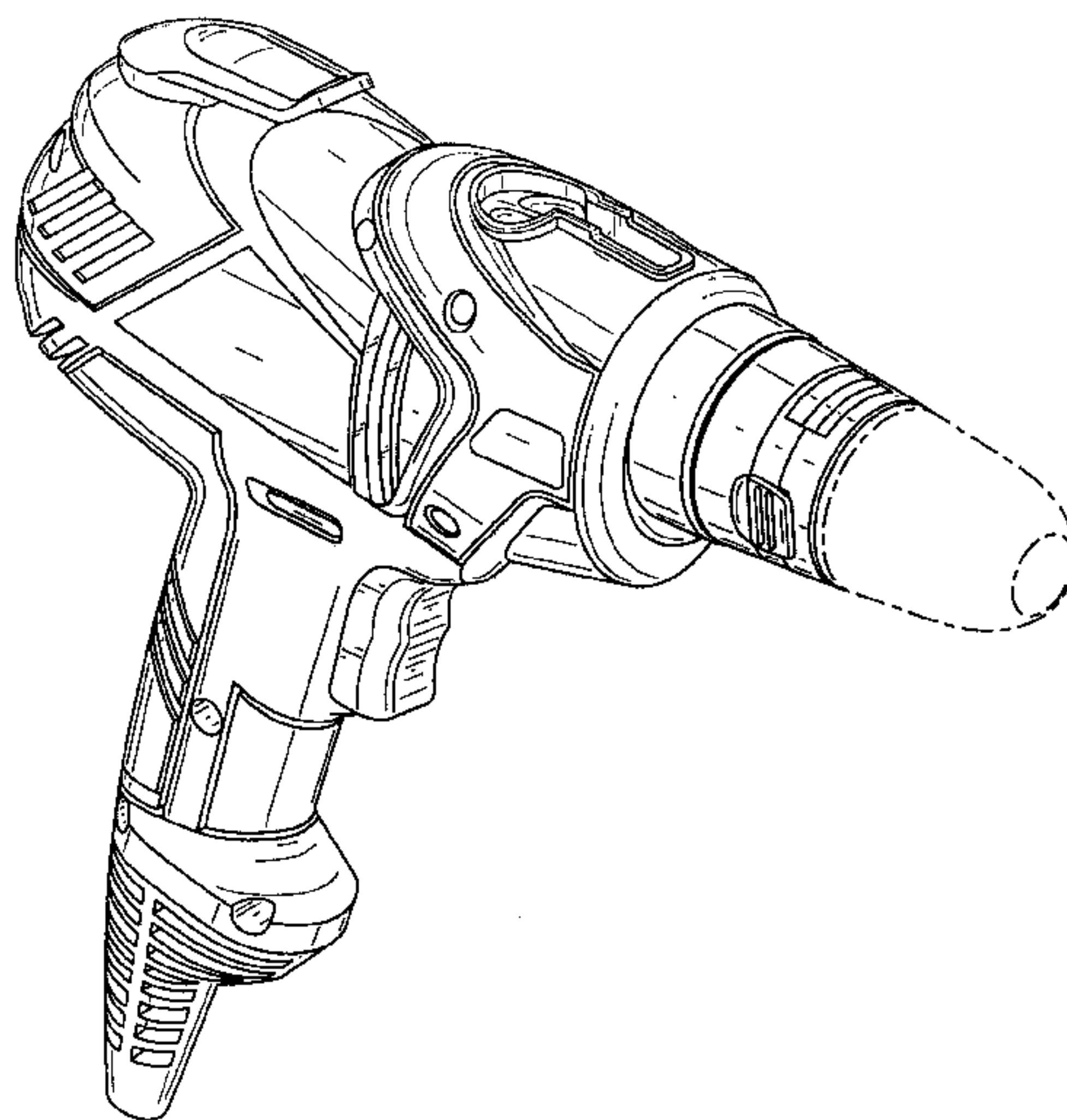

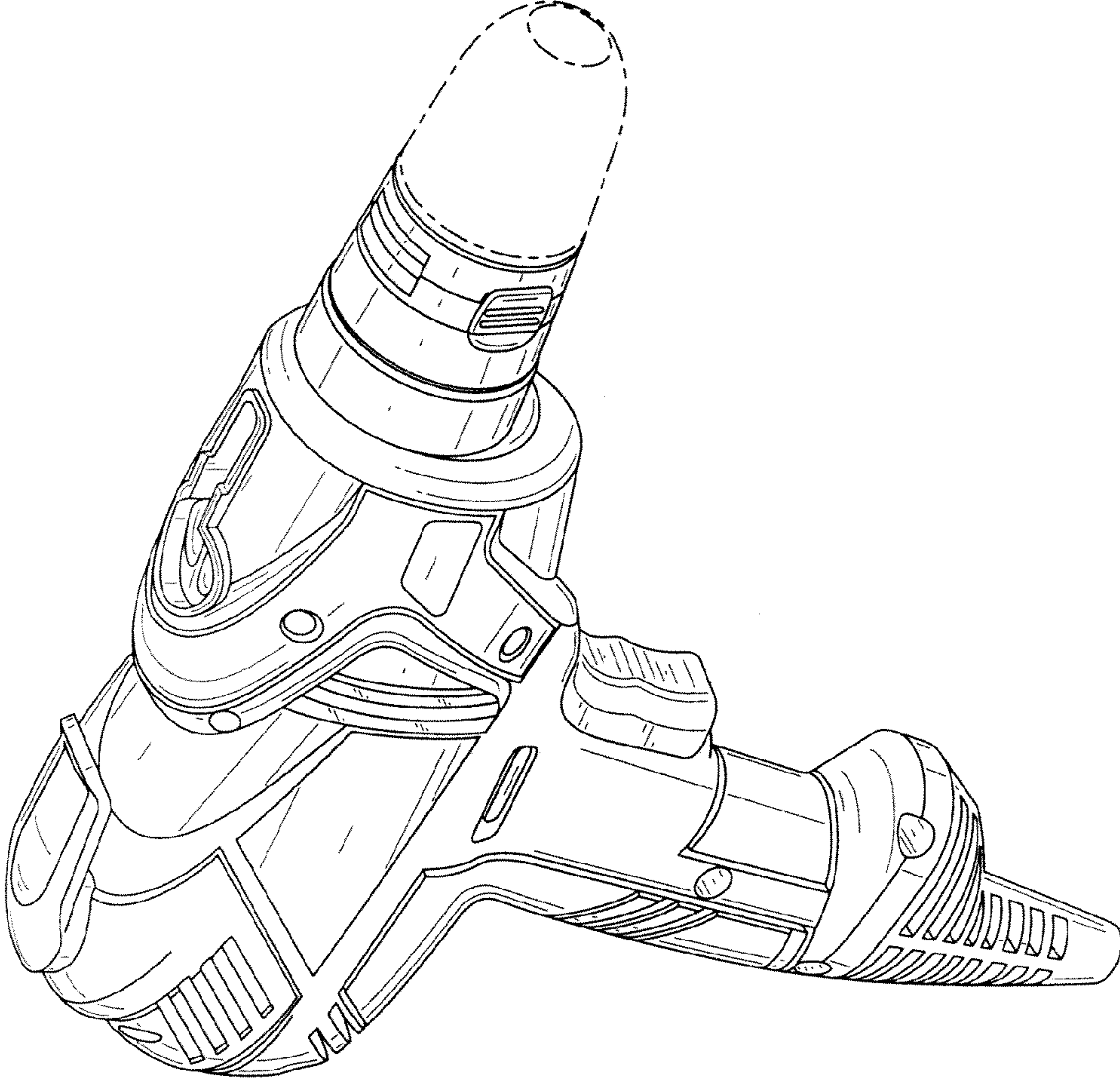

FIG. 1

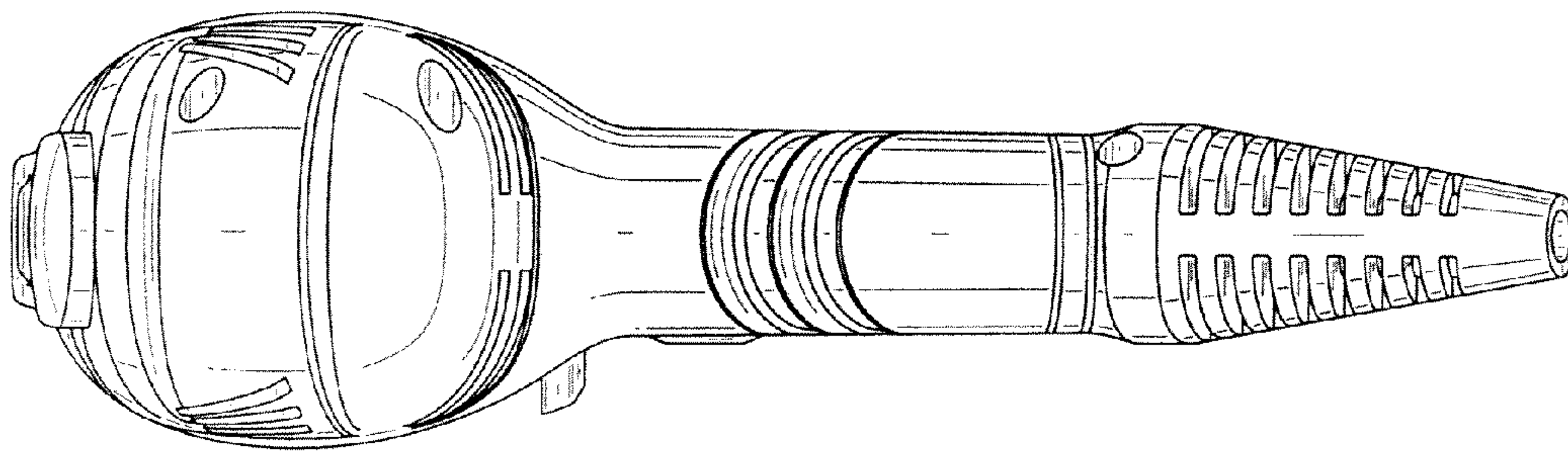

FIG. 3

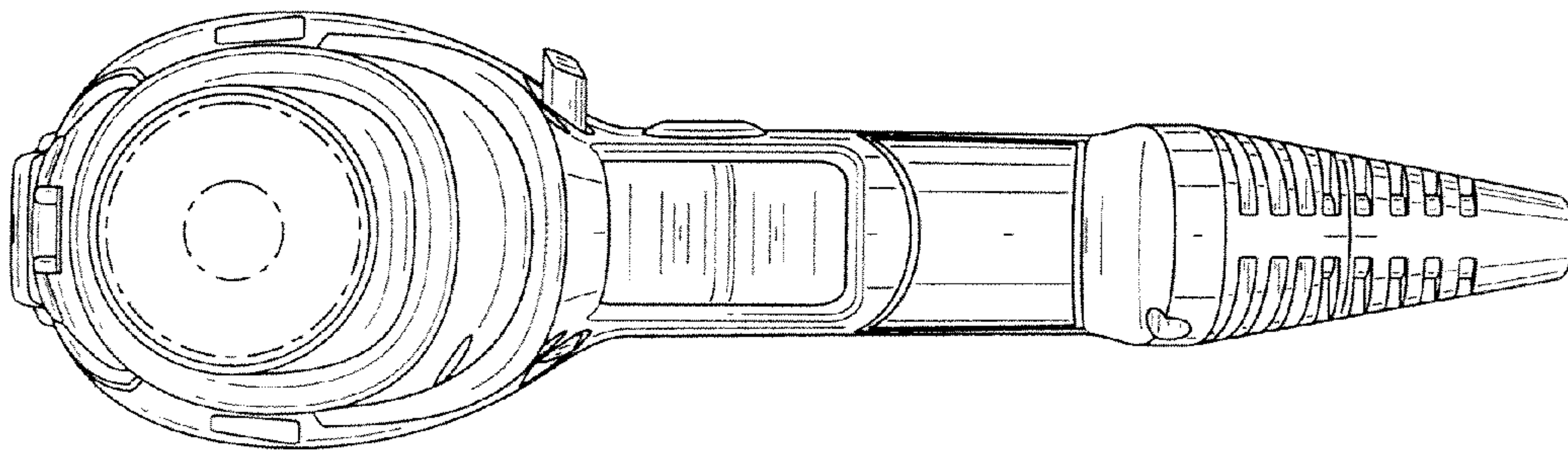

FIG. 2



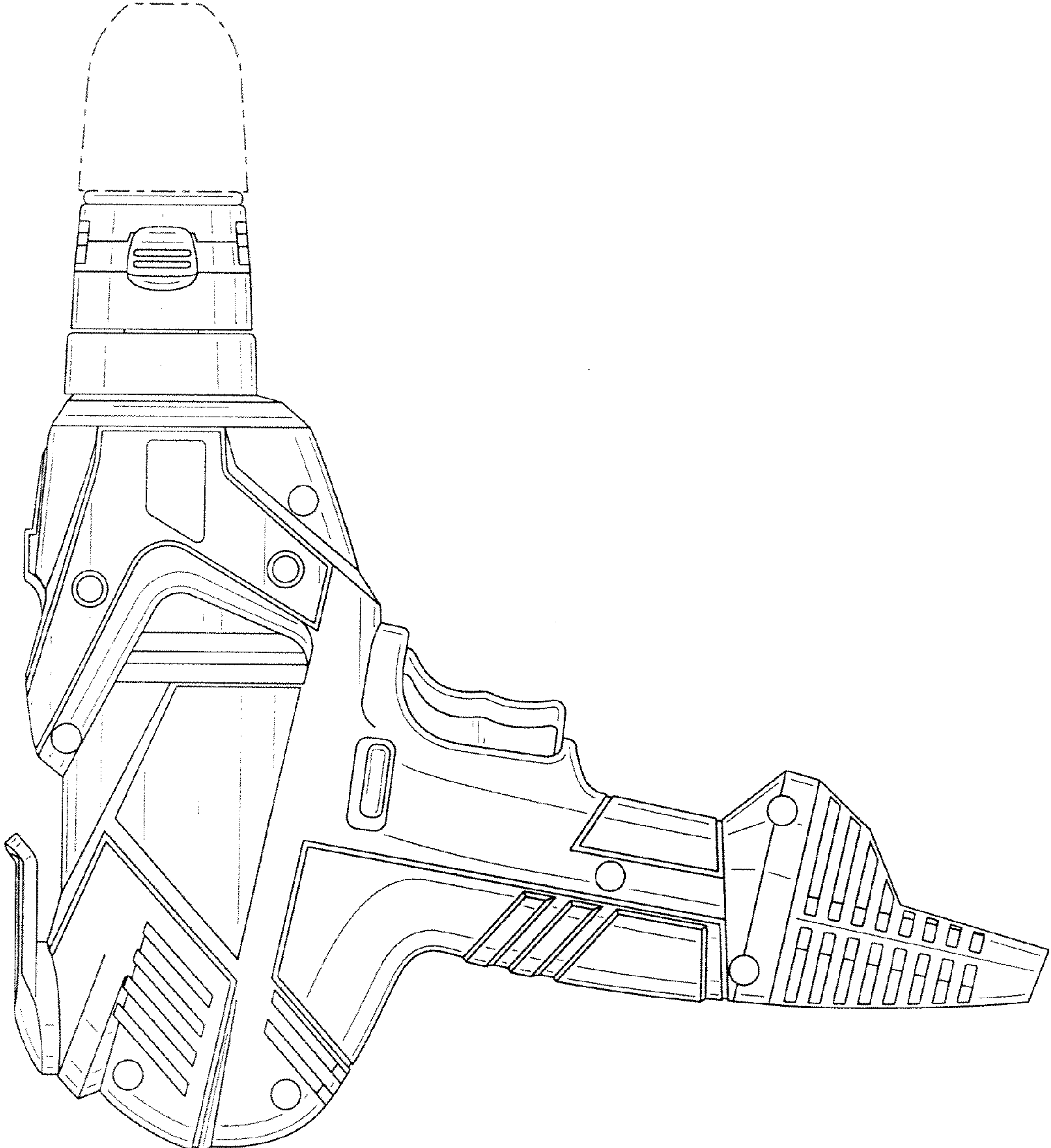

FIG. 4

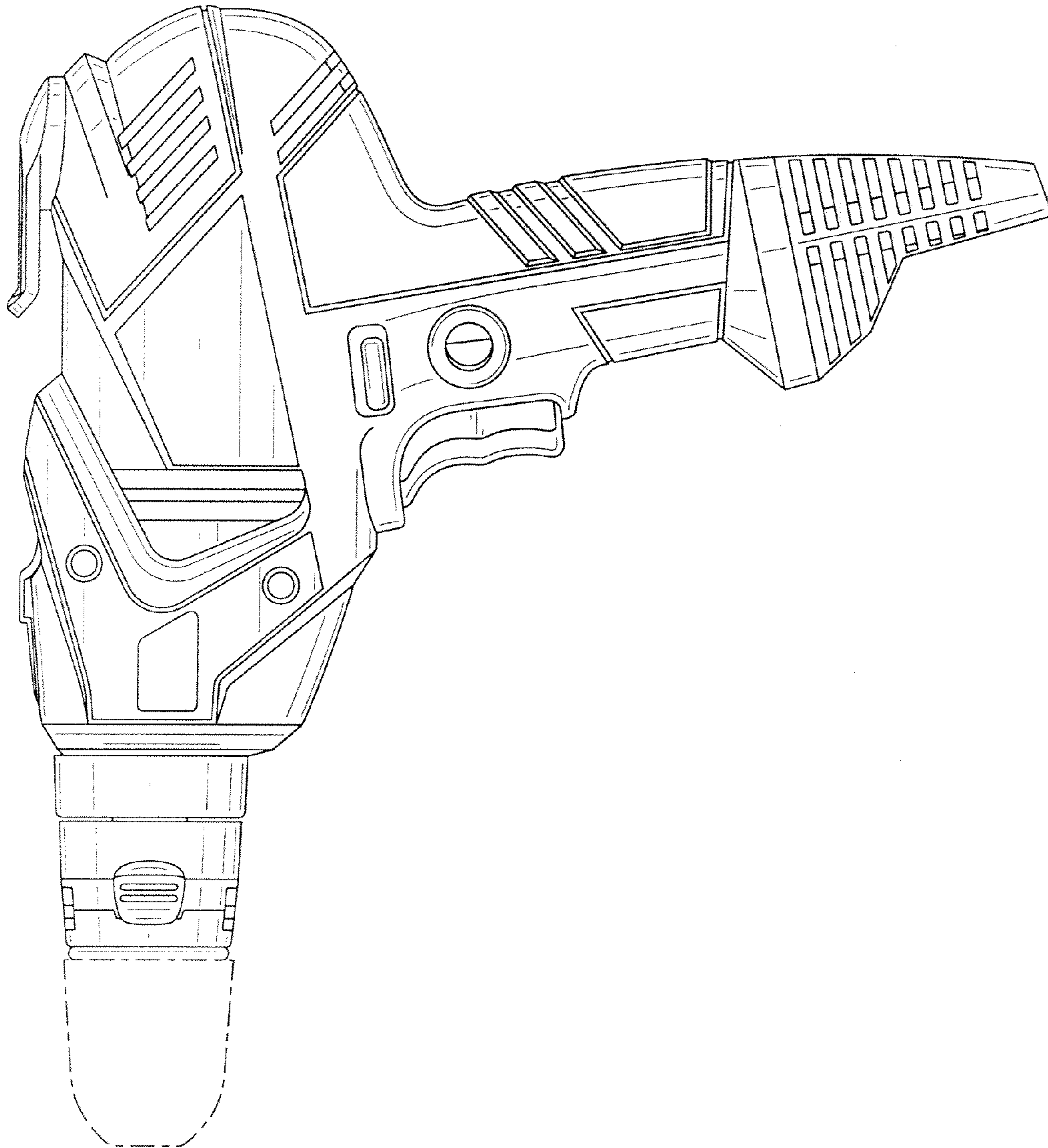

FIG. 5

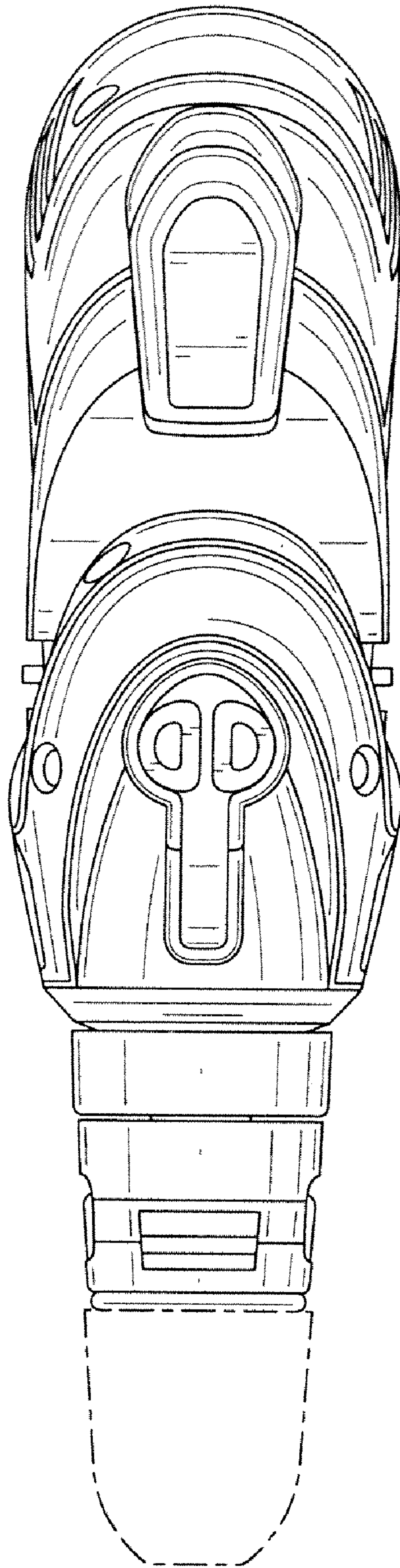

FIG. 6

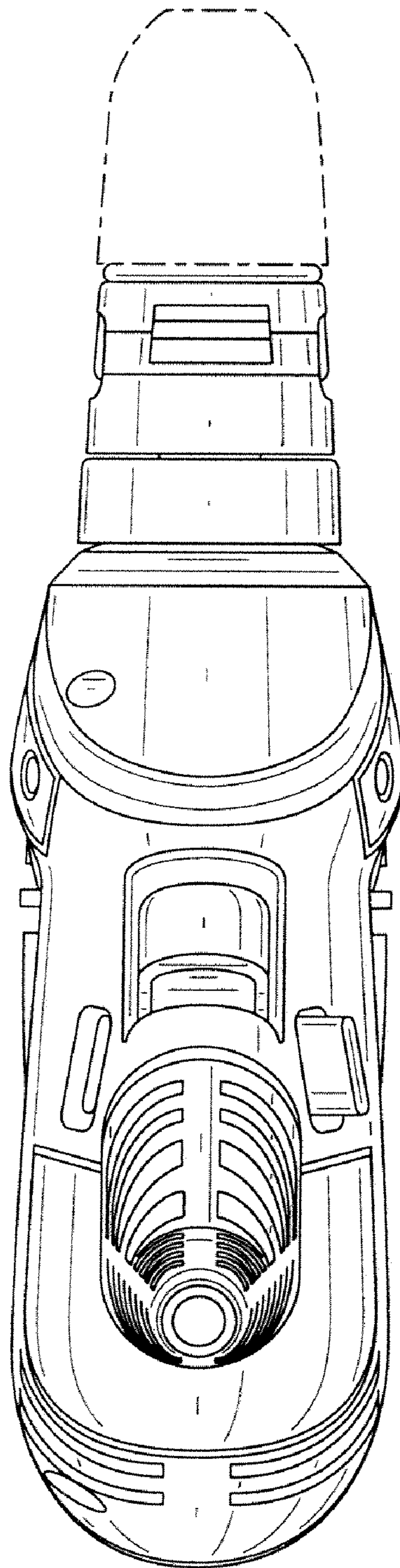

FIG. 7



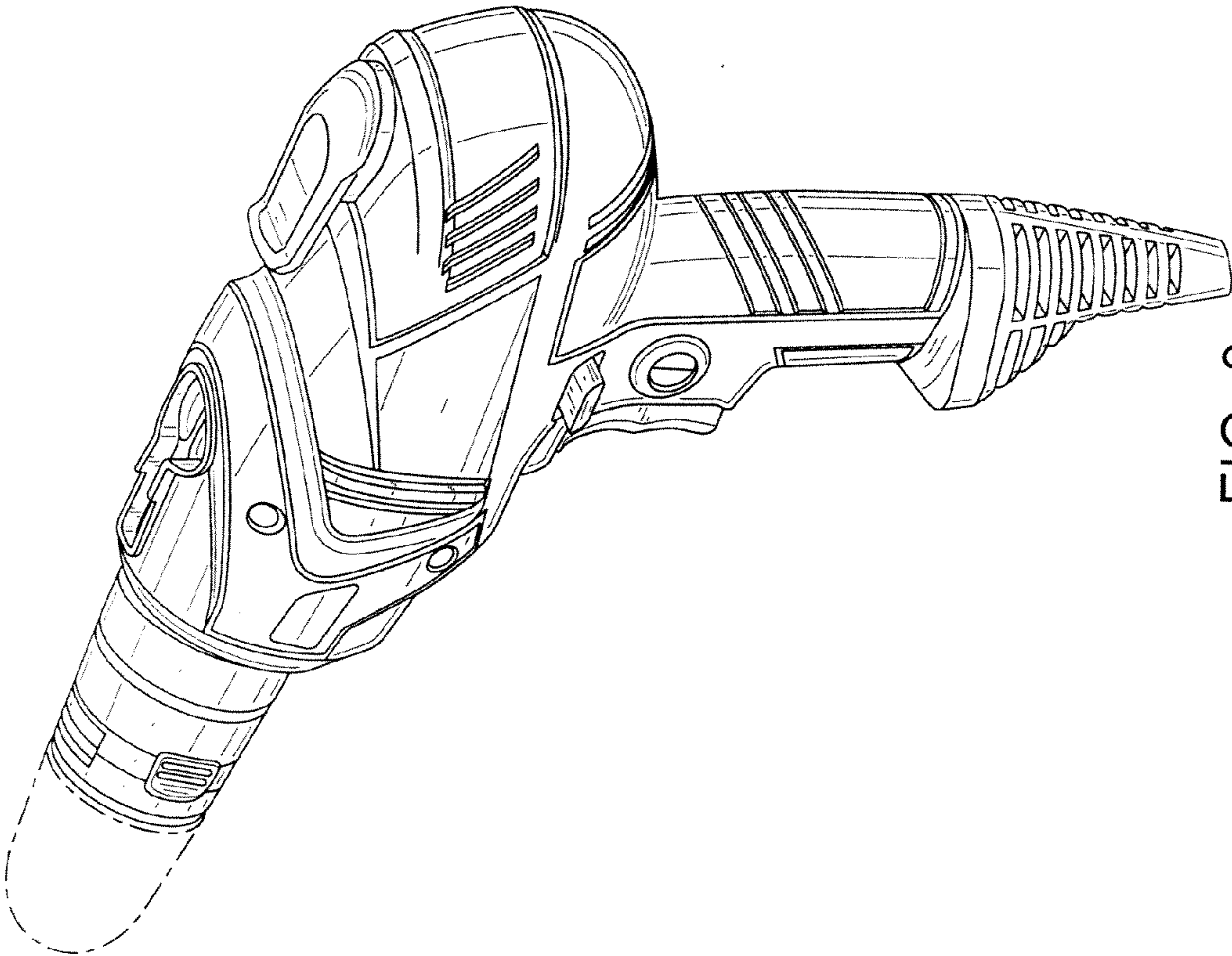

FIG. 8