



US00D593603S

(12) **United States Design Patent**
Good

(10) **Patent No.:** **US D593,603 S**
(45) **Date of Patent:** **** Jun. 2, 2009**

(54) **CARPENTER'S PENCIL**

(75) Inventor: **Mark D. Good**, Wauconda, IL (US)

(73) Assignee: **Sears Brands, LLC**, Hoffman Estates, IL (US)

(**) Term: **14 Years**

(21) Appl. No.: **29/297,053**

(22) Filed: **Nov. 2, 2007**

(51) **LOC (9) Cl.** **19-06**

(52) **U.S. Cl.** **D19/41**

(58) **Field of Classification Search** D19/35,
D19/36, 41, 42, 43, 44, 45, 46, 47, 48, 49,
D19/50, 51, 54, 55, 56, 57; 24/11 F, 11 P,
24/11 R; 401/52, 99, 100, 104, 105, 106,
401/107, 108, 109, 192, 195, 196, 202, 209,
401/213, 243, 244, 245, 246, 247; 708/107

See application file for complete search history.

(56) **References Cited**

U.S. PATENT DOCUMENTS

D5,377 S *	11/1871	Johnson	D19/46
3,941,488 A *	3/1976	Maxwell	401/17
4,404,643 A *	9/1983	Ojima et al.	708/107
D282,378 S *	1/1986	Ohyabu et al.	D19/43
4,832,942 A *	5/1989	Crace	428/41.1
D303,124 S *	8/1989	Li	D19/36
D308,075 S *	5/1990	Yazaki	D19/43
D335,146 S *	4/1993	Katami et al.	D19/57
D335,147 S *	4/1993	Katami et al.	D19/57
D344,978 S *	3/1994	Monzyk	D19/42
D419,541 S *	1/2000	Kawashima	D14/431
D462,090 S *	8/2002	Debbas	D19/47
D466,933 S *	12/2002	Ferrara, Jr.	D19/47
6,491,464 B1 *	12/2002	Young	401/35

D484,912 S *	1/2004	Briggl	D19/55
6,752,556 B2 *	6/2004	Pearce	401/6
D501,877 S	2/2005	Granick		
D524,372 S *	7/2006	Granick	D19/36
D540,867 S *	4/2007	Koch	D19/51
D541,340 S *	4/2007	Qiu	D19/43
D543,273 S *	5/2007	Young et al.	D24/114
D559,385 S *	1/2008	Boone et al.	D24/133
D576,213 S *	9/2008	Fei	D19/47
D577,072 S *	9/2008	Qiu	D19/51
2007/0025800 A1	2/2007	Burry et al.		

* cited by examiner

Primary Examiner—Elizabeth A Albert

Assistant Examiner—Karen E Eldridge Powers

(74) *Attorney, Agent, or Firm*—Greenberg Traurig, LLP

(57) **CLAIM**

What is claimed is the ornamental design for a carpenter's pencil, as shown and described.

DESCRIPTION

FIG. 1 is a front perspective view of a carpenter's pencil showing my new design;

FIG. 2 is a top plan view thereof;

FIG. 3 is a bottom plan view thereof;

FIG. 4 is a front elevational view thereof;

FIG. 5 is a rear elevational view thereof;

FIG. 6 is a left side elevational view thereof; and,

FIG. 7 is a right side elevational view thereof.

The dotted lines showing a pencil lead in the drawings illustrate environmental matter and form no part of the claimed design.

1 Claim, 2 Drawing Sheets

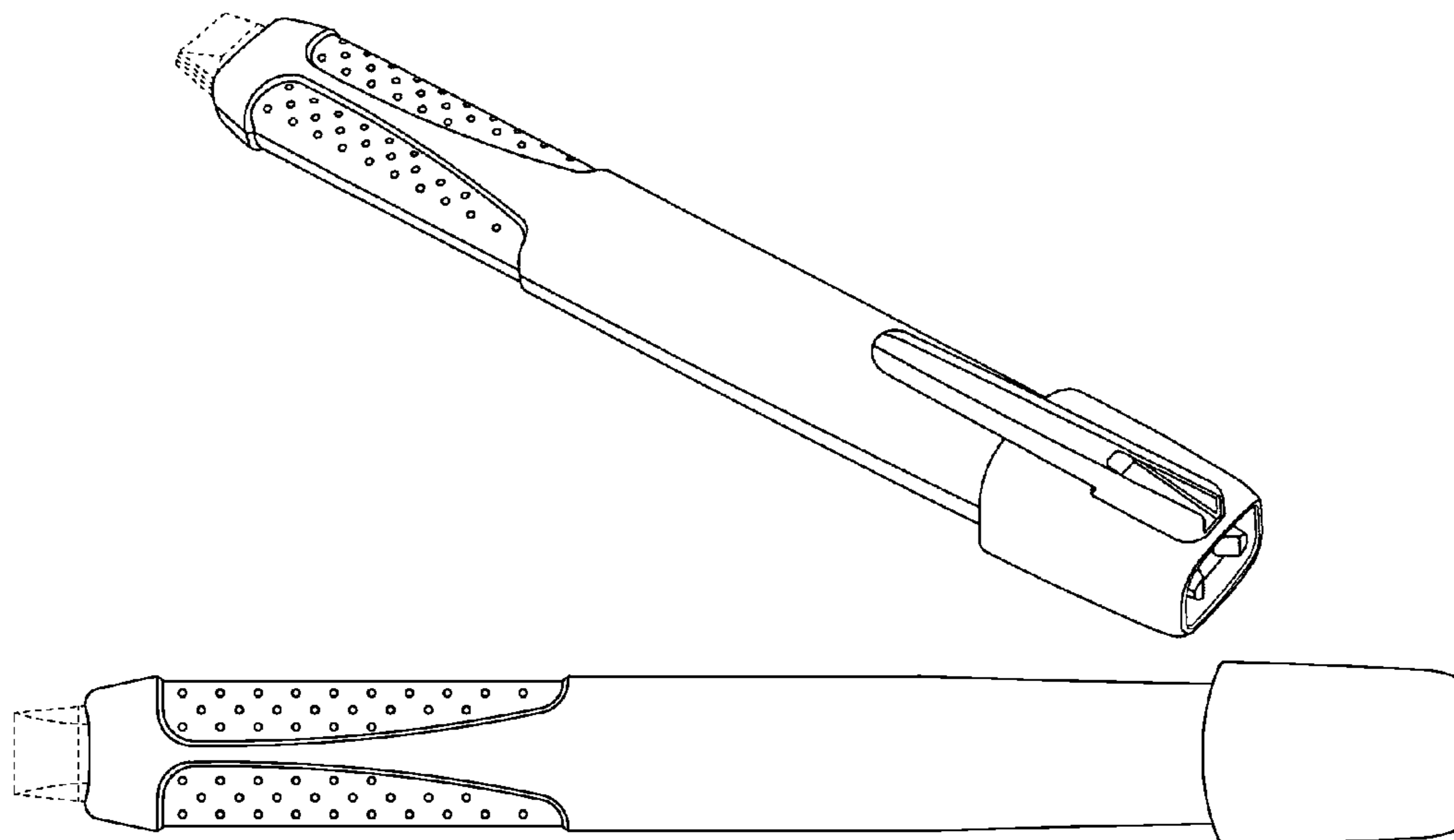

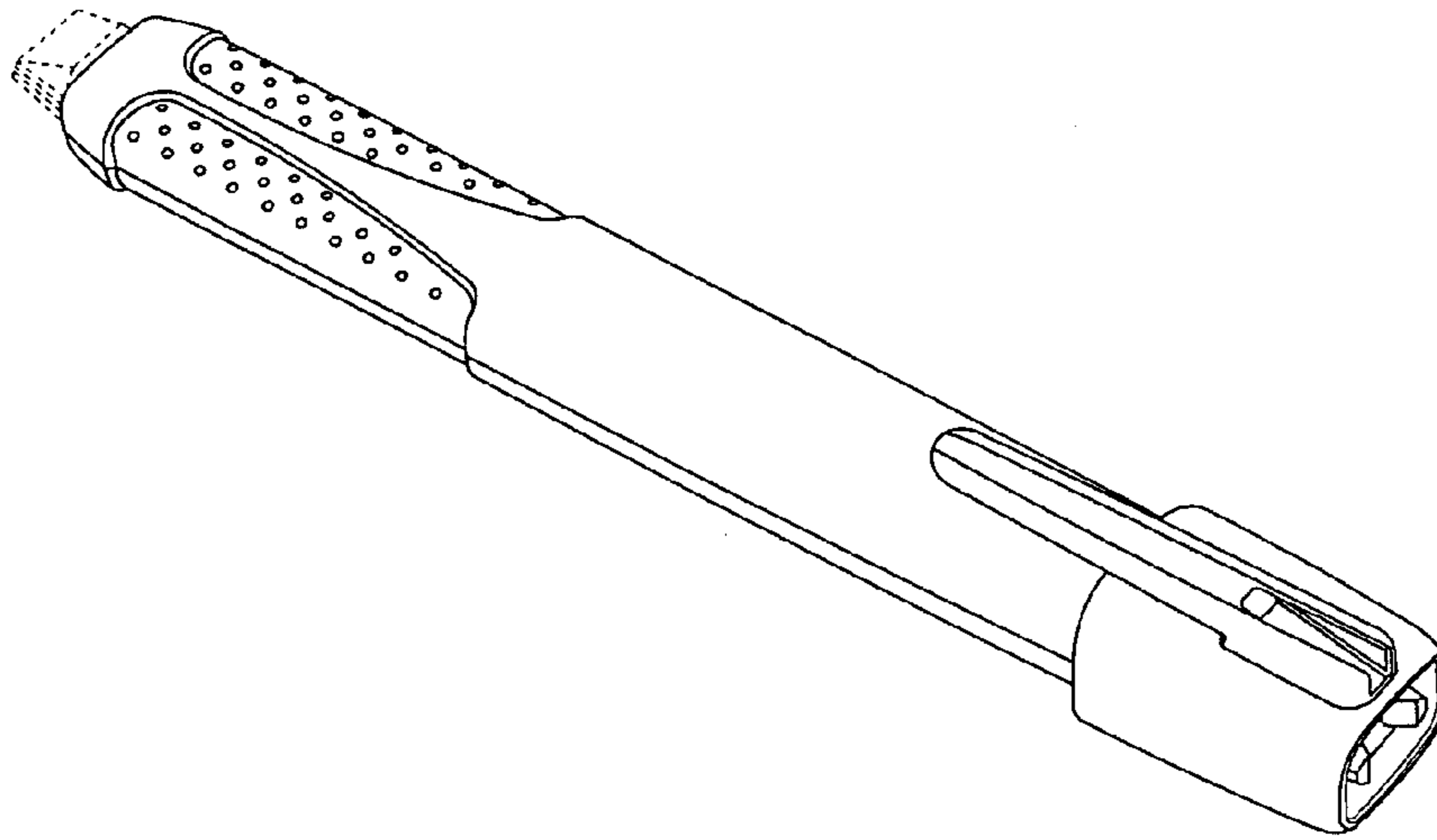

FIG. 1

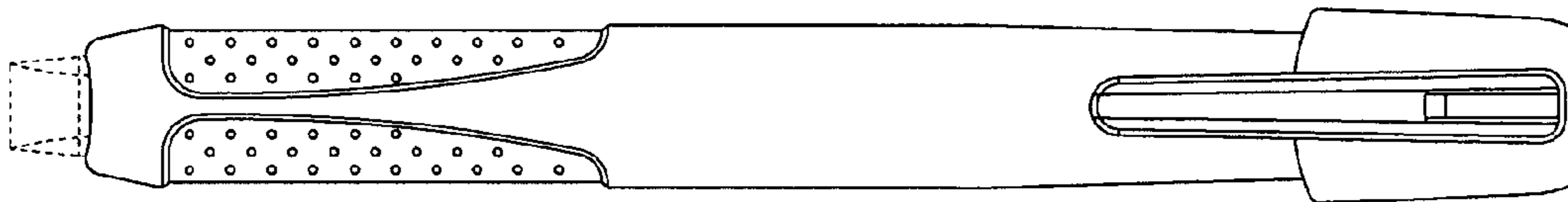

FIG. 2

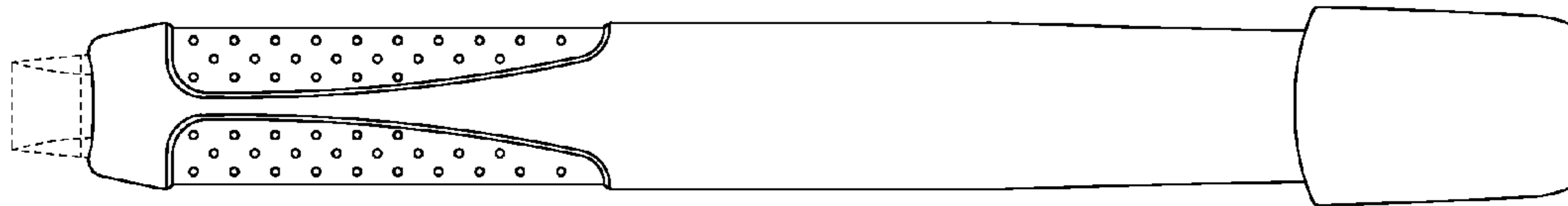

FIG. 3

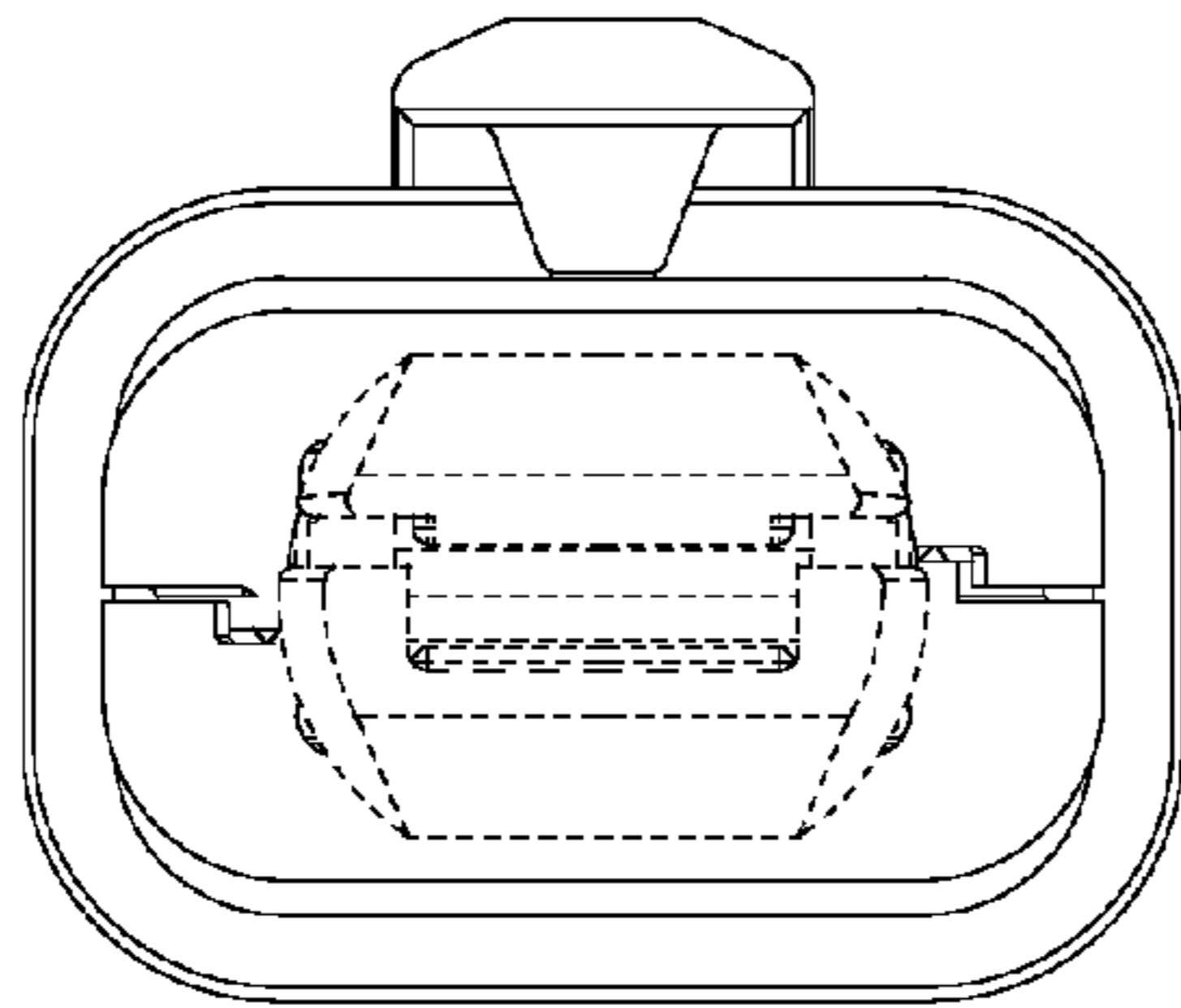

FIG. 4

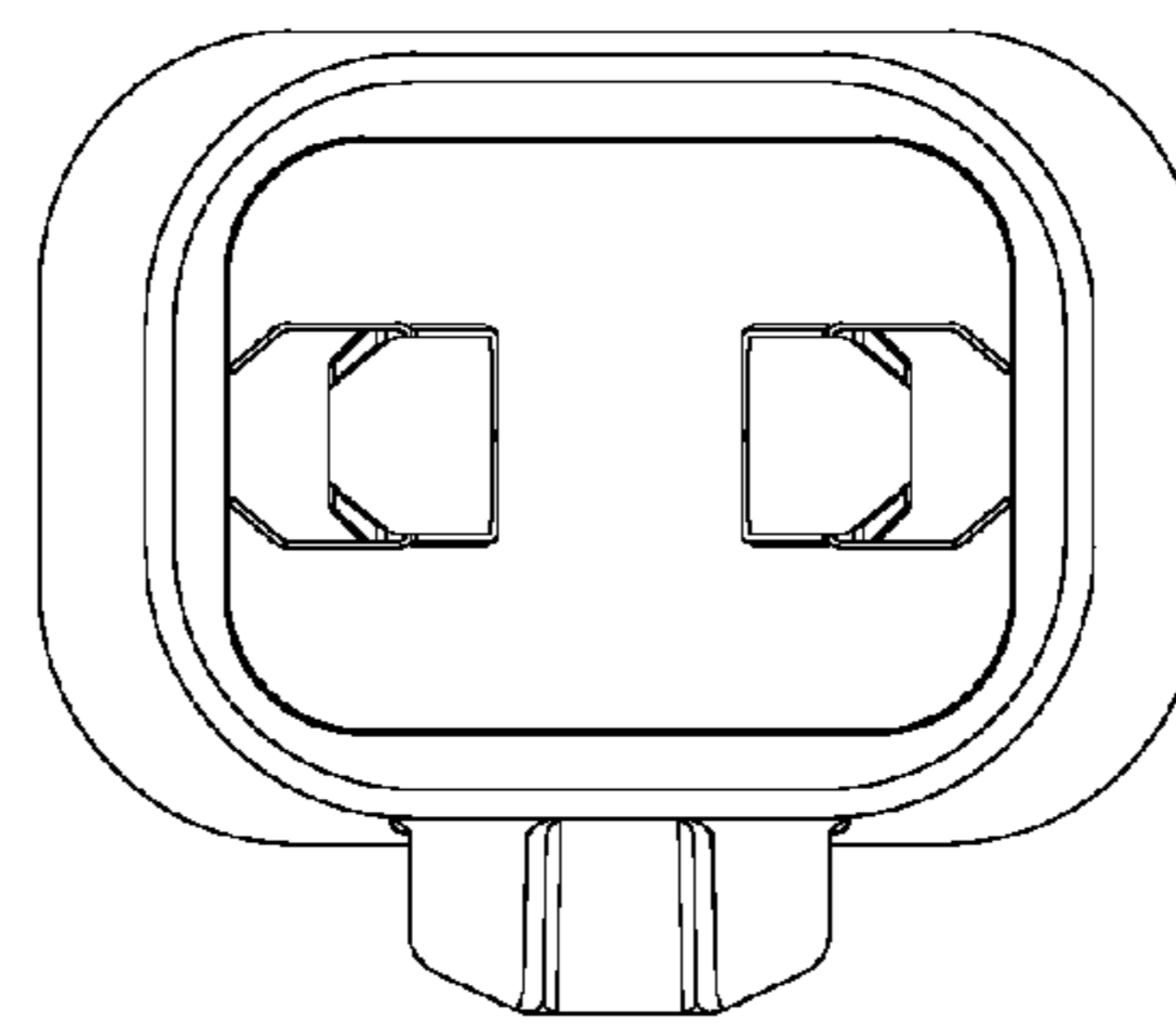

FIG. 5

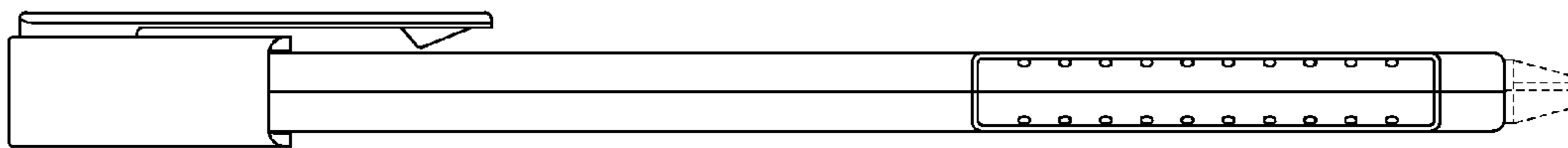

FIG. 6

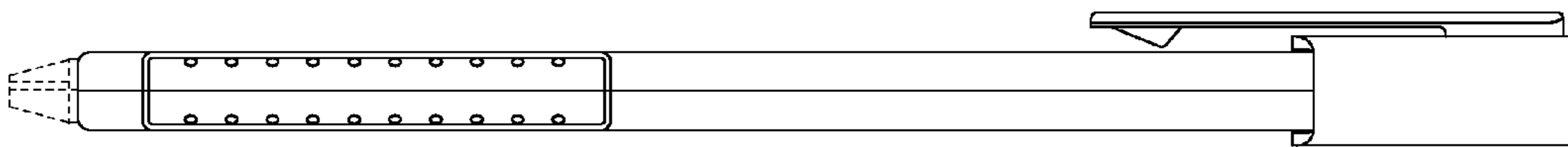

FIG. 7