



US00D593486S

(12) **United States Design Patent**  
**Yonetsu**

(10) **Patent No.:** **US D593,486 S**  
(45) **Date of Patent:** **\*\* Jun. 2, 2009**

(54) **AUTOMOBILE TIRE**

(75) Inventor: **Isao Yonetsu**, Osaka (JP)

(73) Assignee: **Toyo Tire & Rubber Co., Ltd.**, Osaka (JP)

(\*\*) Term: **14 Years**

(21) Appl. No.: **29/327,823**

(22) Filed: **Nov. 13, 2008**

(30) **Foreign Application Priority Data**

Oct. 27, 2008 (JP) ..... 2008-027536

(51) **LOC (9) Cl.** ..... **12-15**

(52) **U.S. Cl.** ..... **D12/605**

(58) **Field of Classification Search** ..... D12/500-501,  
D12/544, 579, 600, 605; 152/523-524, DIG. 12,  
152/555; D7/570-576

See application file for complete search history.

(56) **References Cited**

**U.S. PATENT DOCUMENTS**

D569,336 S \* 5/2008 Onoe ..... D12/605  
D569,791 S \* 5/2008 Iwabuchi et al. .... D12/605  
D574,766 S \* 8/2008 Iwabuchi et al. .... D12/605  
D576,544 S \* 9/2008 Onoe ..... D12/605

**FOREIGN PATENT DOCUMENTS**

JP D1137214 S 3/2002

JP D1171775 S 4/2003

\* cited by examiner

*Primary Examiner*—Stacia Cadmus

(74) *Attorney, Agent, or Firm*—Westerman, Hattori, Daniels & Adrian, LLP.

(57) **CLAIM**

The ornamental design for an automobile tire, as shown and described.

**DESCRIPTION**

FIG. 1 is a front, elevation view of the automobile tire;  
FIG. 2 is a rear, elevation view of the automobile tire;  
FIG. 3 is a left-side, elevation view of the automobile tire;  
FIG. 4 is a top, plan view of the automobile tire;  
FIG. 5 is a perspective view of the automobile tire;  
FIG. 6 is an enlarged view of the part A1-B1 in FIG. 1;  
FIG. 7 is an enlarged cross-section view taken along the line E1-E1 of FIG. 6, in the part C1-C1 of FIG. 4 and the part D-D of FIG. 6  
FIG. 8 is an enlarged view of the part A2-B2 in FIG. 1; and,  
FIG. 9 is an enlarged cross-section view taken along the line G1-G1 of FIG. 8, in the part C1-C1 of FIG. 4 and the part F-F on FIG. 6.

The broken line showing of the tire is included for the purpose of illustrating environment and forms no part of the claimed design.

**1 Claim, 9 Drawing Sheets**

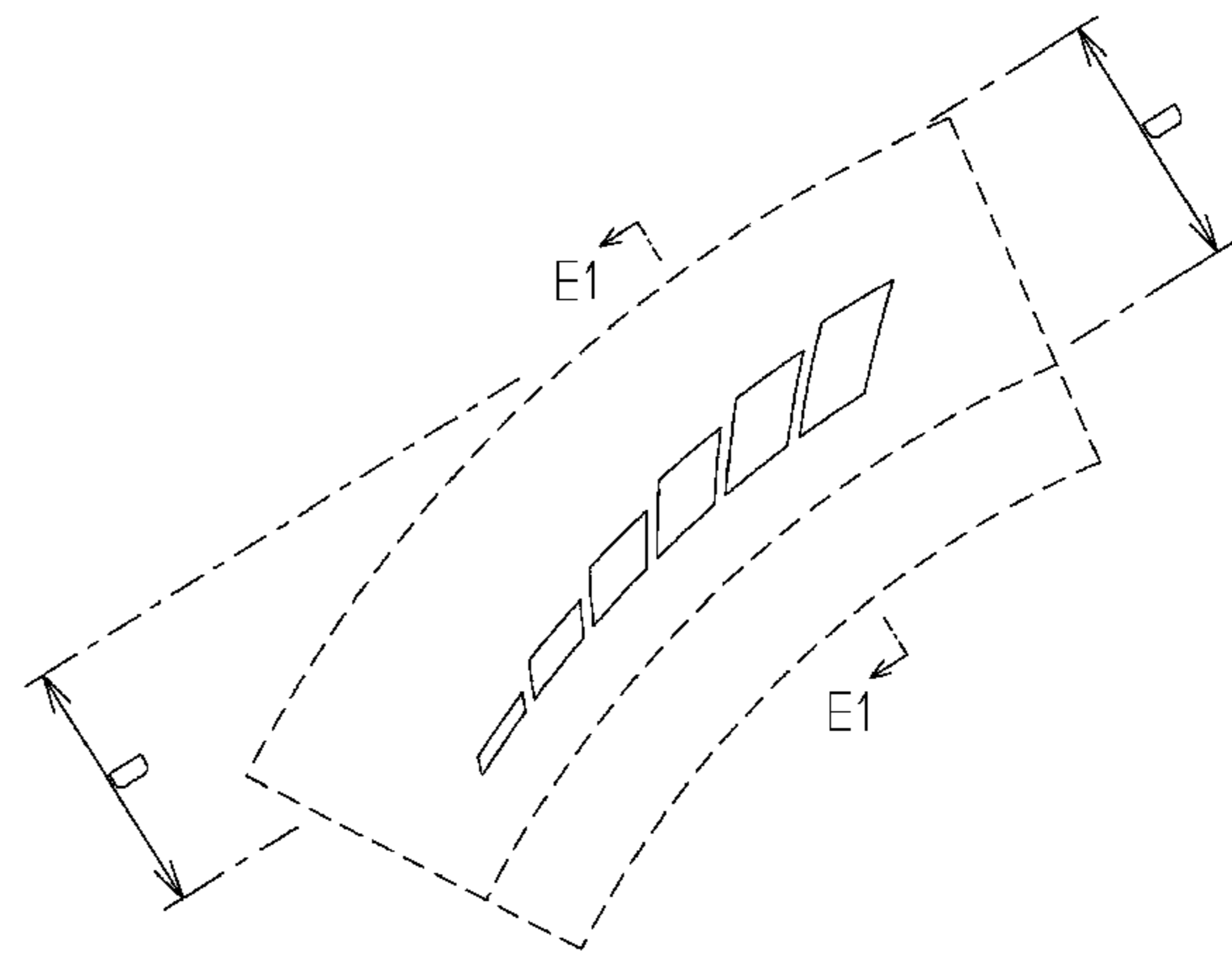
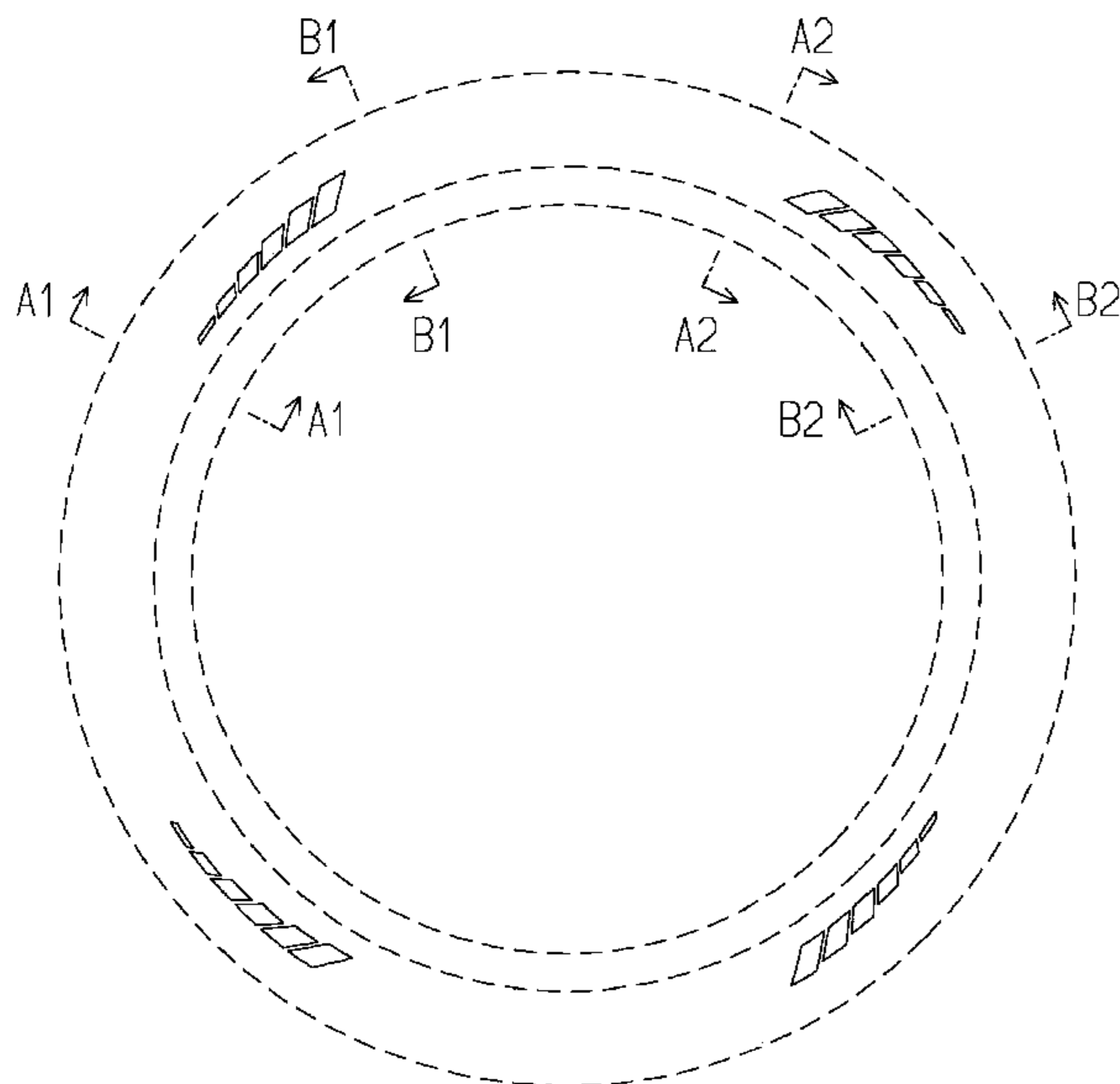

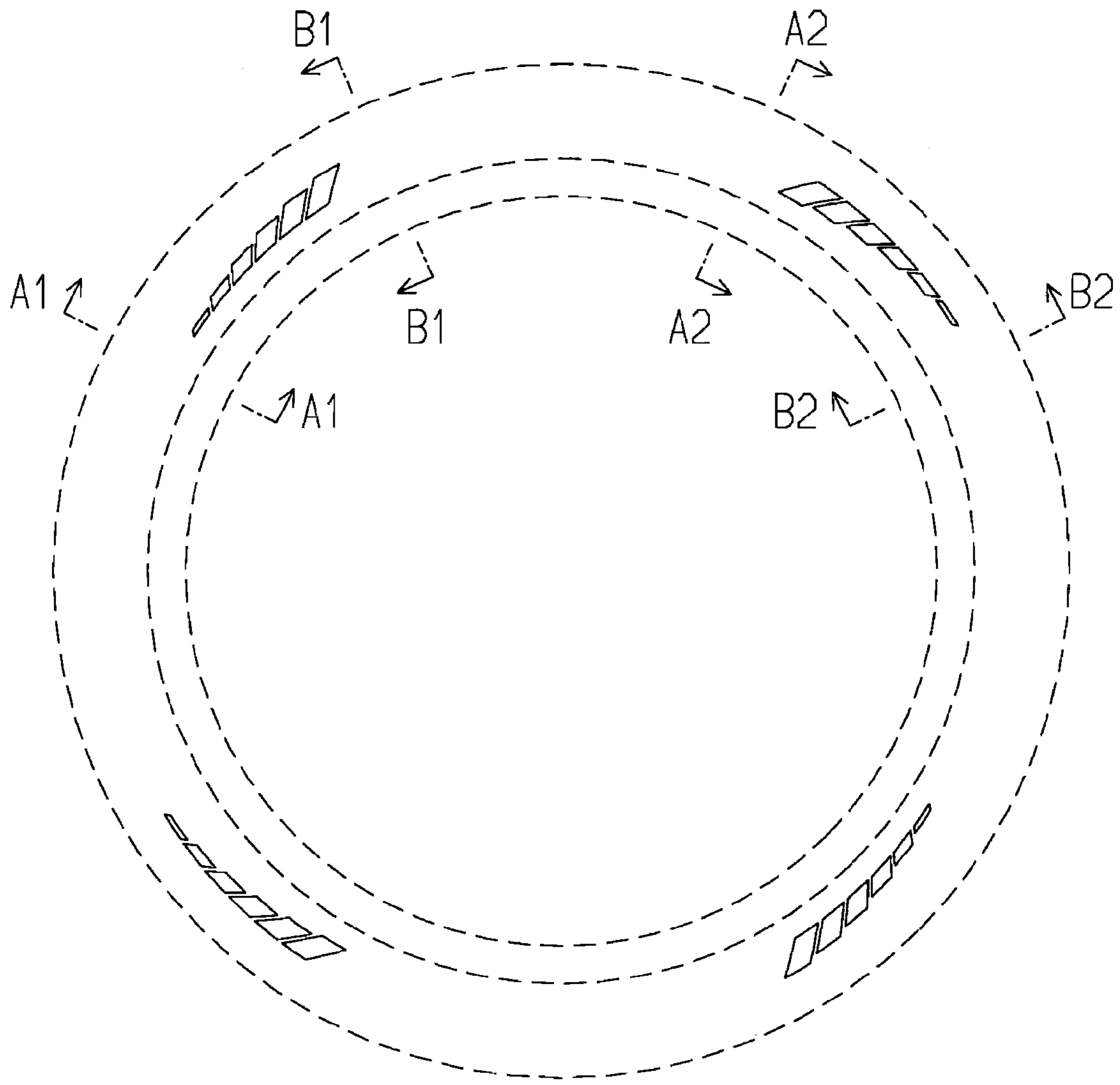

FIG.1

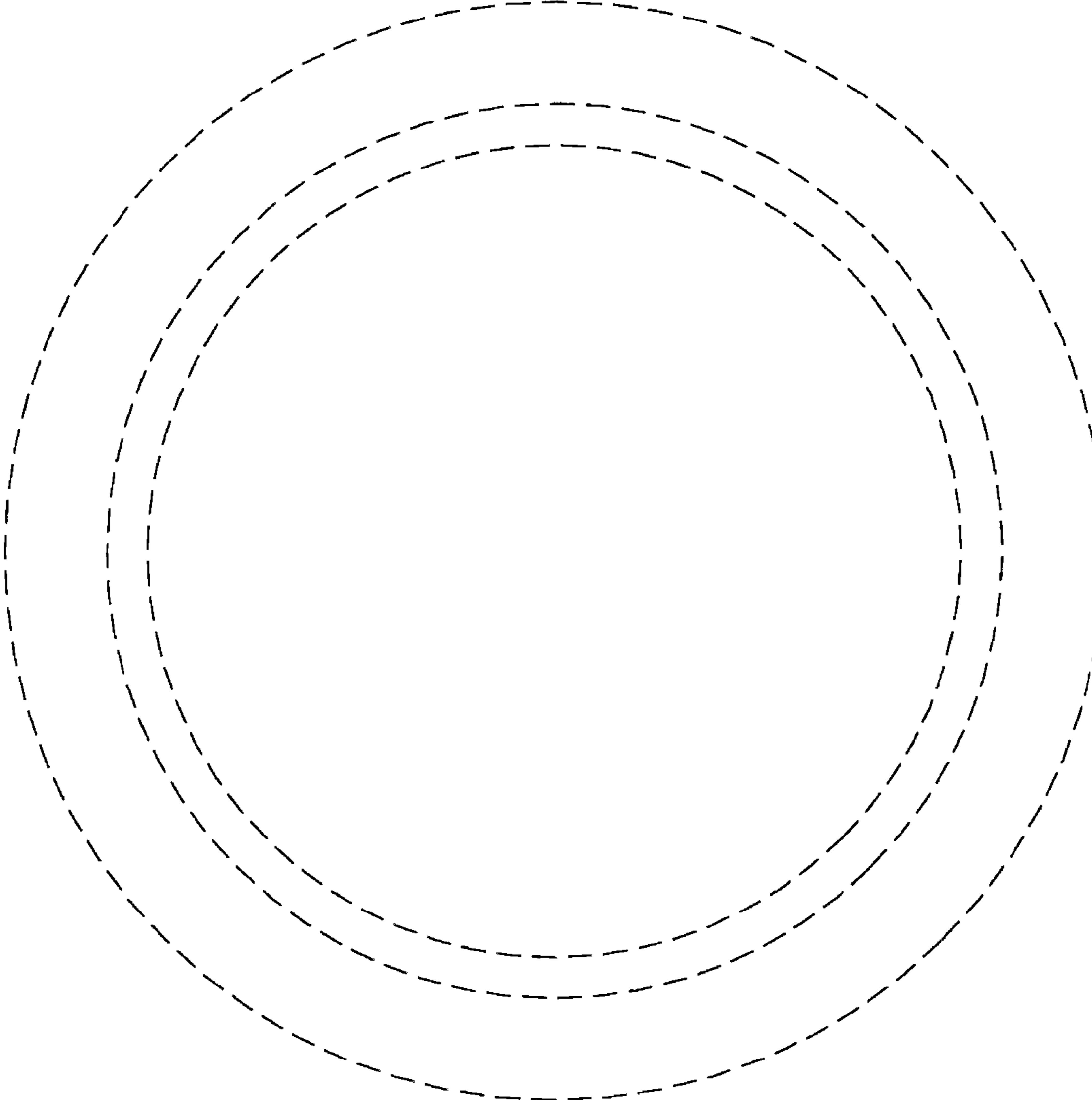

FIG.2

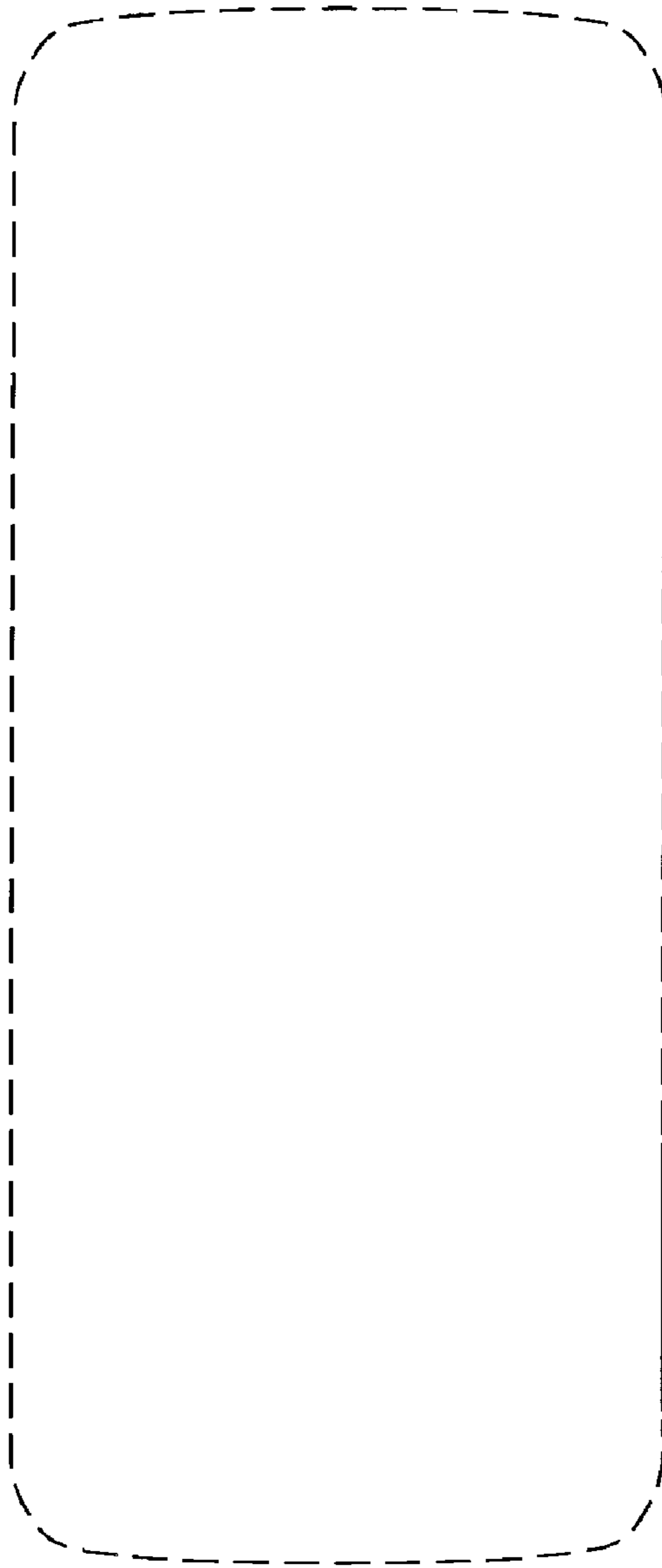

FIG.3

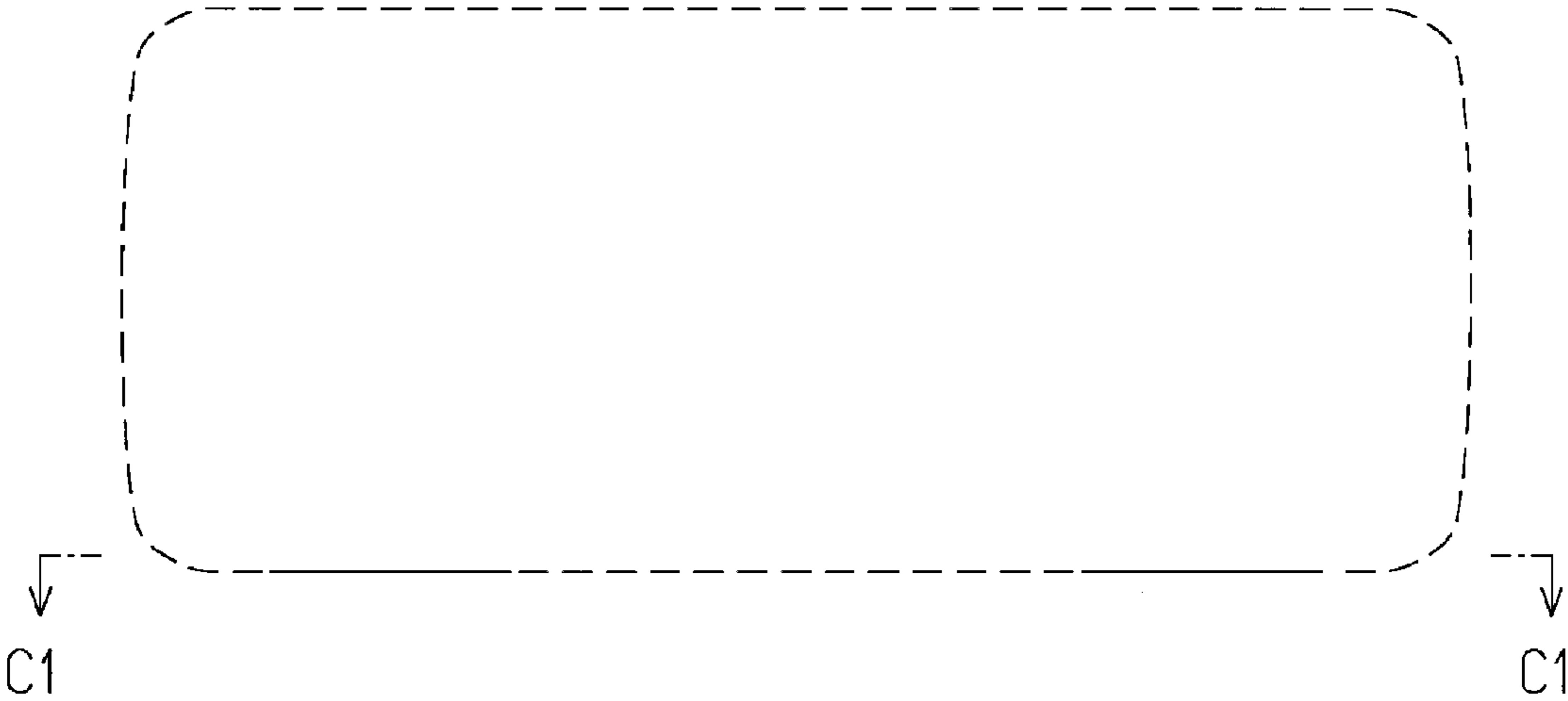

FIG.4

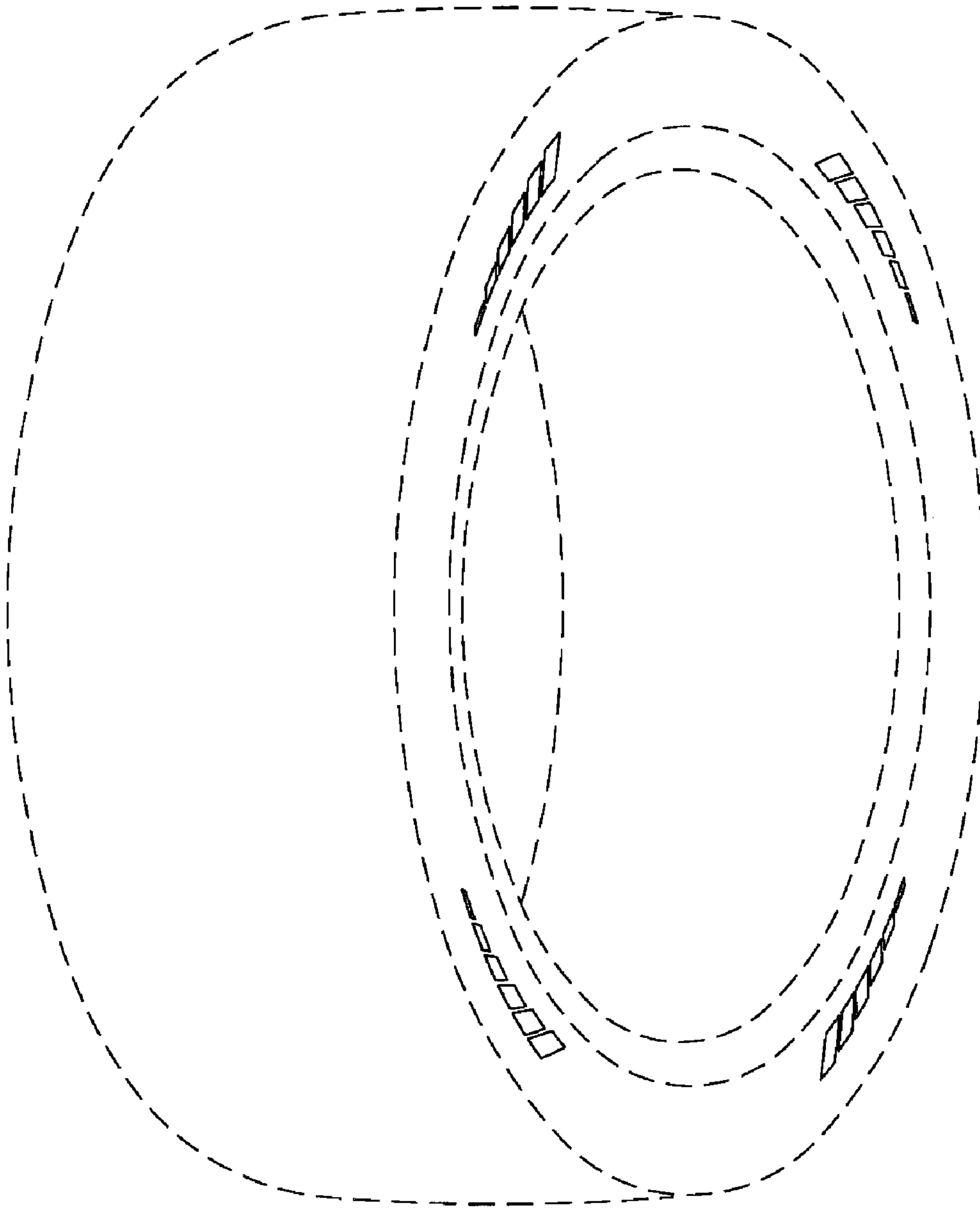

FIG.5

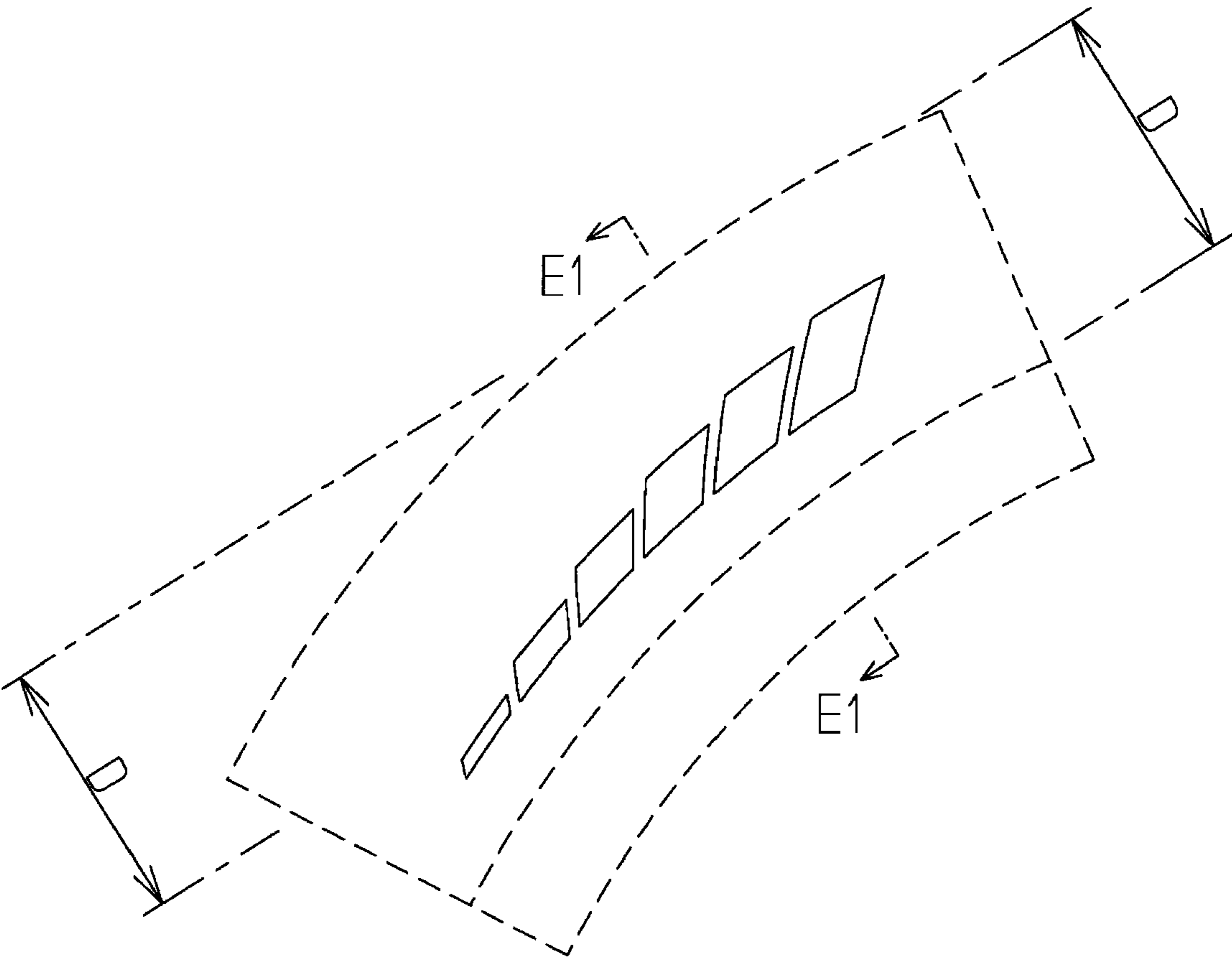

FIG.6

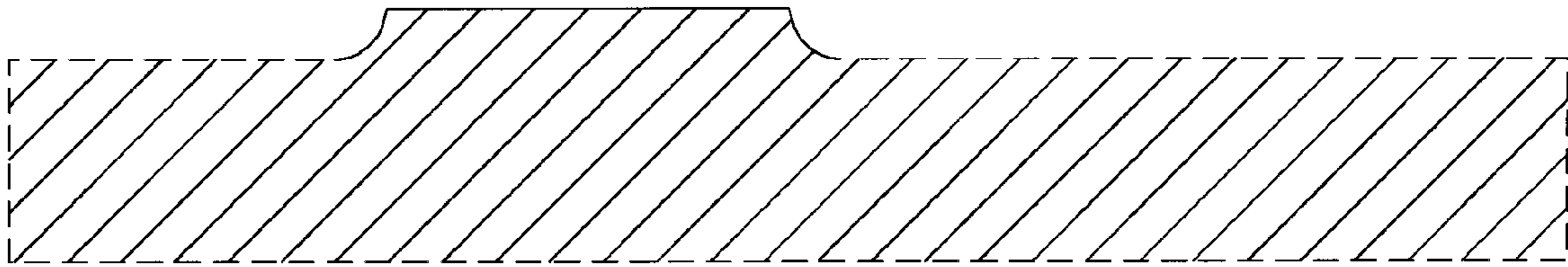

FIG.7



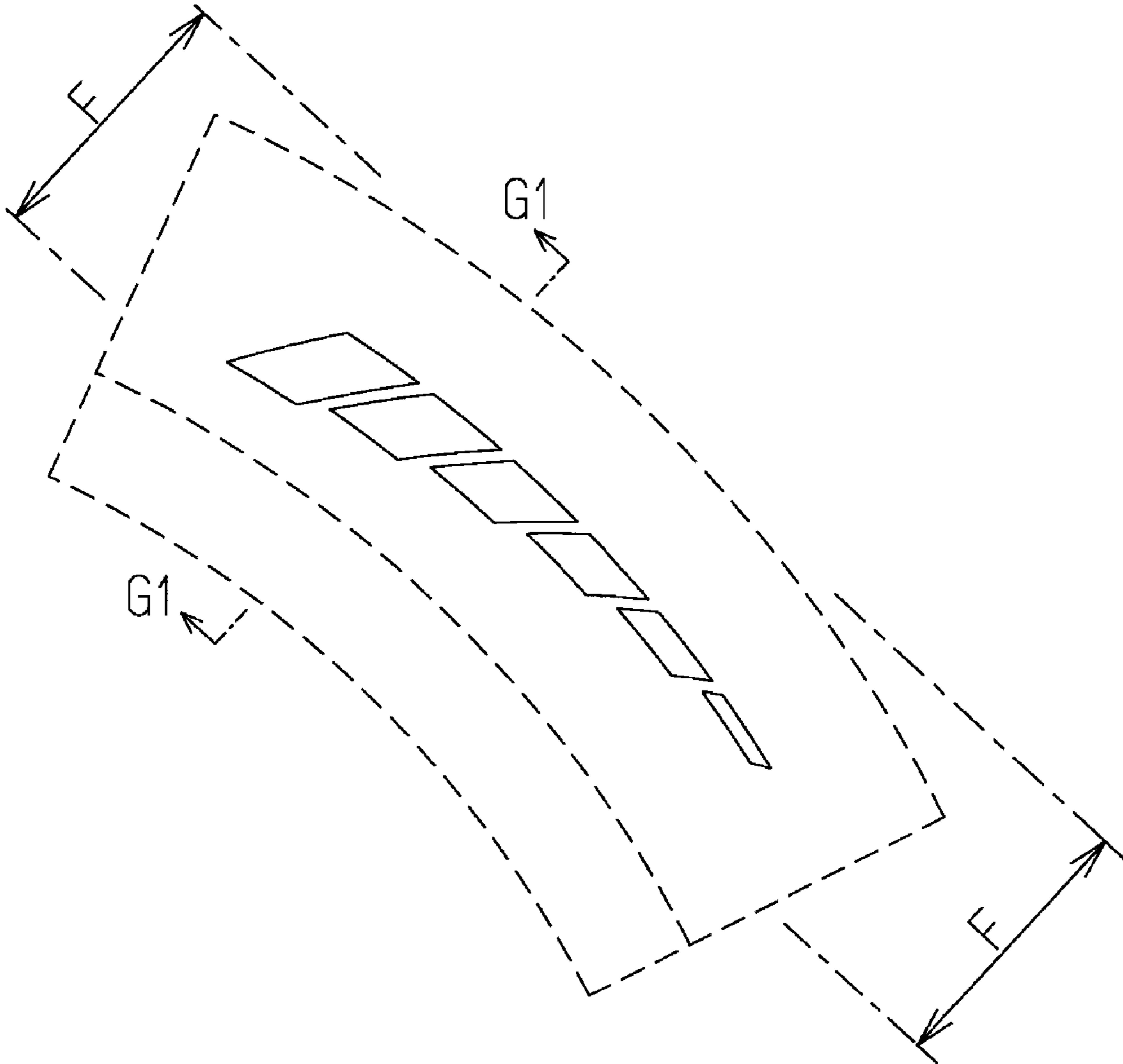

FIG.8

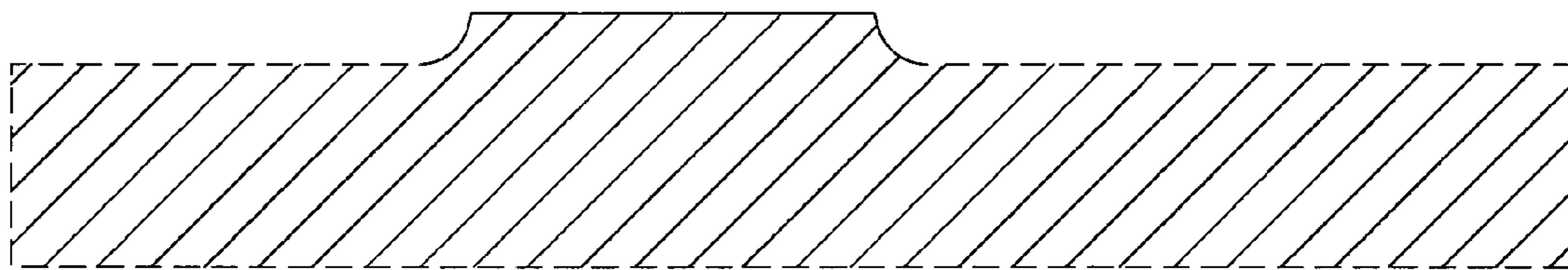

FIG.9