

US00D593464S

(12) **United States Design Patent**
Mentis

(10) **Patent No.:** **US D593,464 S**

(45) **Date of Patent:** **** Jun. 2, 2009**

(54) **ATTACHMENT FOR A HANDLEBAR**

(76) **Inventor:** **Roy Mentis**, 8 Mentis Avenue,
Bedfordview (ZA) 2007

(**) **Term:** **14 Years**

(21) **Appl. No.:** **29/298,074**

(22) **Filed:** **Nov. 28, 2007**

(51) **LOC (9) Cl.** **12-11**

(52) **U.S. Cl.** **D12/178**

(58) **Field of Classification Search** D12/110,
D12/114, 174, 178; 74/551.1–551.9, 488,
74/488 R, 489, 625; 180/219, 333, 321,
180/220, 170, 178, 179, 335; 200/4, 61.27,
200/61.54, 157, 293.1, 553, 310, 313, 314;
D8/80, 94, 107, 303; 280/288.4

See application file for complete search history.

(56) **References Cited**

U.S. PATENT DOCUMENTS

- 604,216 A * 5/1898 Raczek 74/551.9
- 604,371 A * 5/1898 Cook 74/551.4
- 643,644 A * 2/1900 Gaylor 74/551.9
- 4,232,565 A * 11/1980 Leonheart 74/489
- D278,593 S * 4/1985 MacGregor D8/83
- D383,660 S * 9/1997 Anderson D8/83
- D443,851 S * 6/2001 Miller D12/174

- D452,423 S * 12/2001 Shimansky D8/83
- 6,434,793 B1 * 8/2002 Ensson 16/421
- D534,843 S * 1/2007 Higashi D12/174
- D556,007 S * 11/2007 Hung D8/107

* cited by examiner

Primary Examiner—Cathron C Brooks

Assistant Examiner—Linda Brooks

(74) *Attorney, Agent, or Firm*—Baker Botts LLP

(57) **CLAIM**

The ornamental design for an attachment for a handlebar, as shown and described.

DESCRIPTION

The throttle control may be used to provide frictional control of the throttle sleeve/grip of the handlebar.

FIG. 1 is a perspective view of the attachment for a handlebar showing my new design.

FIG. 2 is a left and right side view of the attachment for a handlebar of FIG. 1; and,

FIG. 3 is a top view of the attachment for a handlebar of FIG. 1.

The throttle sleeve and grip portions of the attachment for a handlebar shown in broken lines form no part of the claimed design.

1 Claim, 2 Drawing Sheets

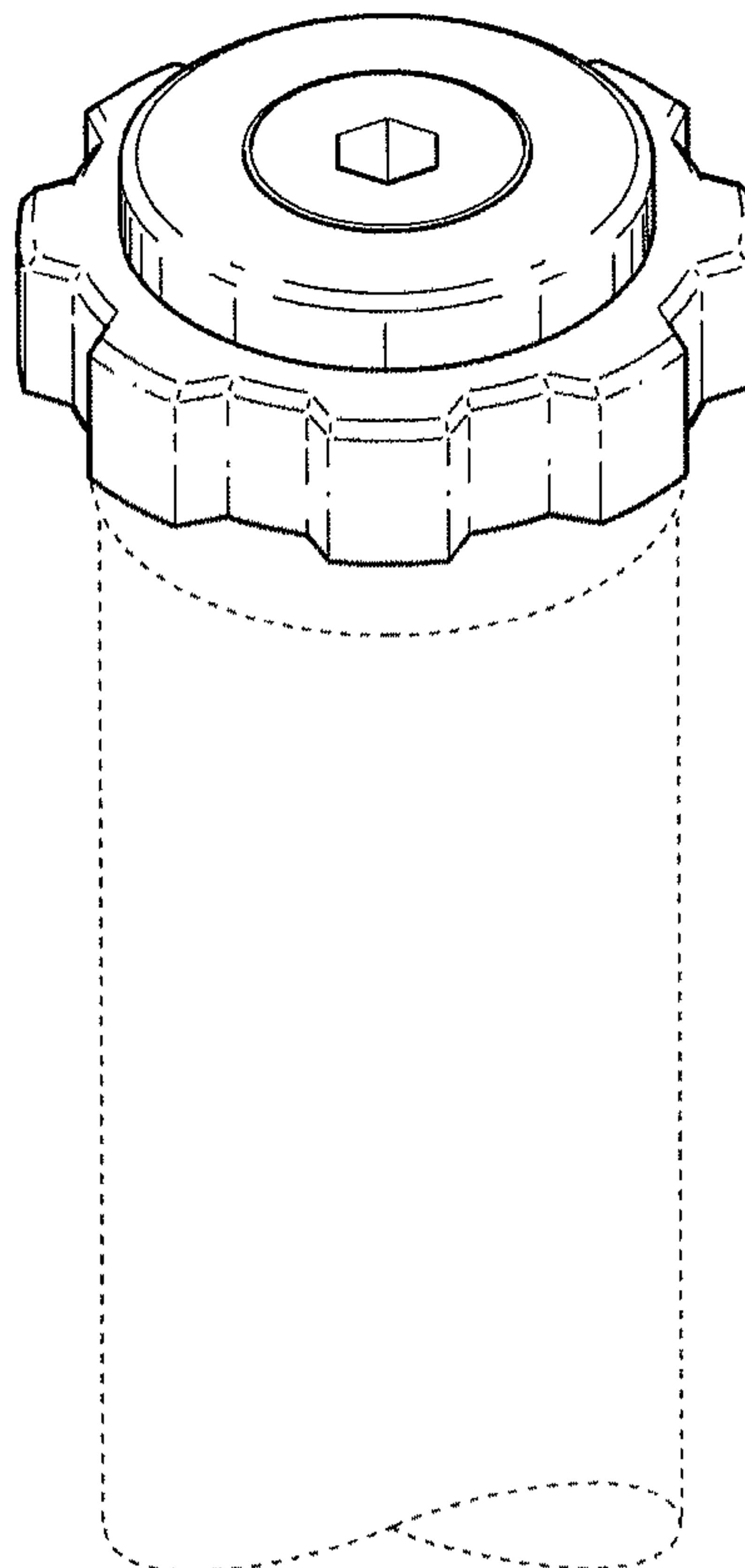

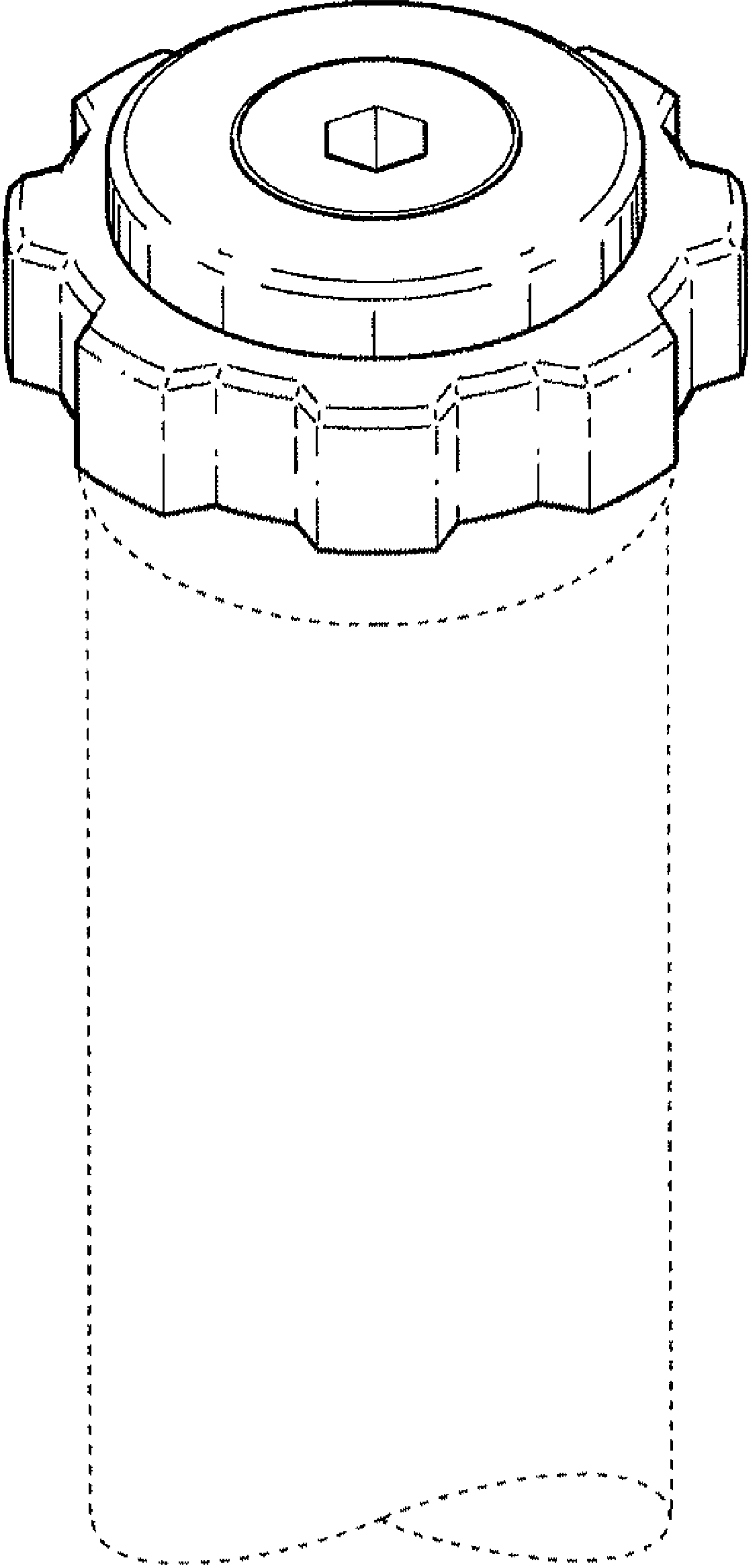

FIGURE 1

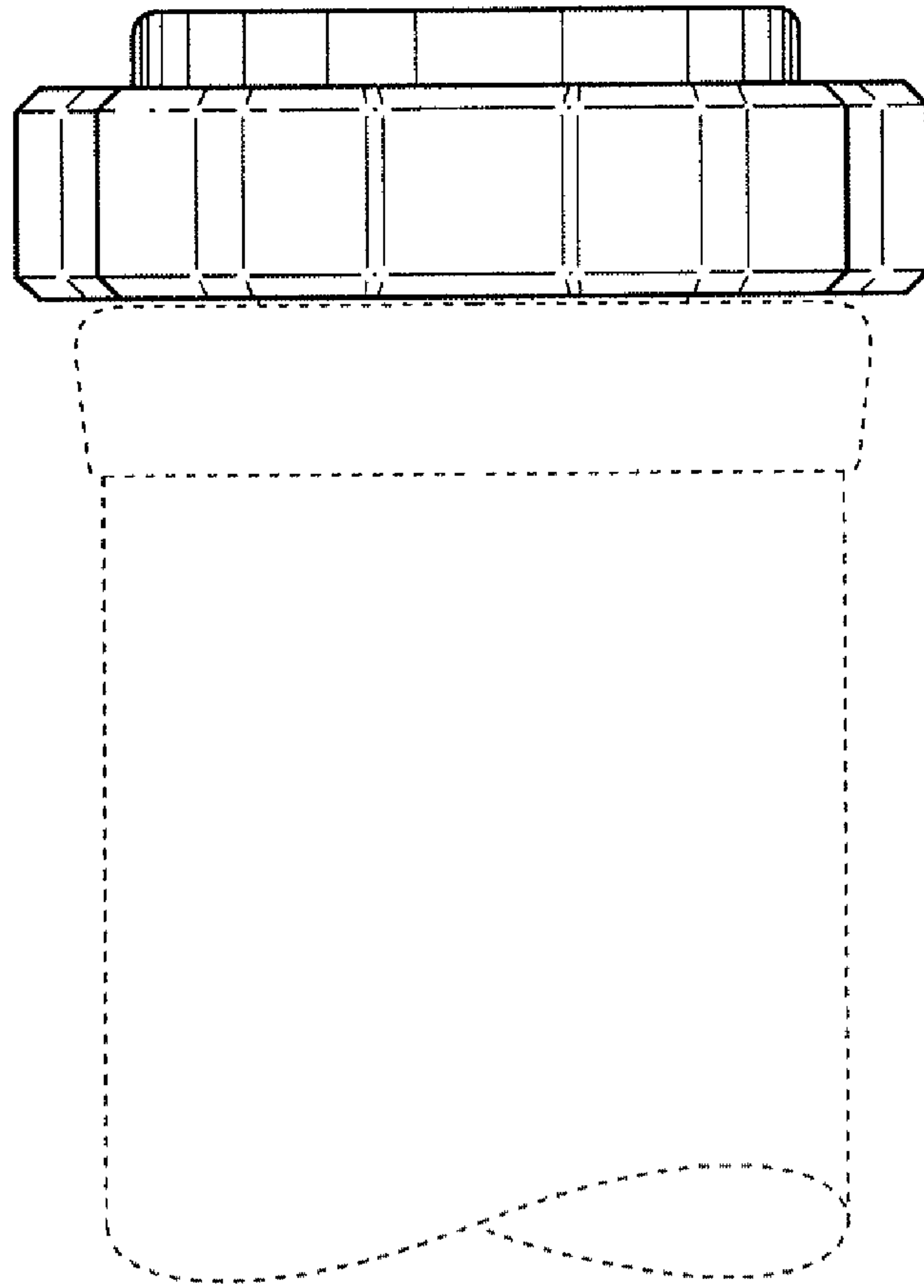

FIGURE 2

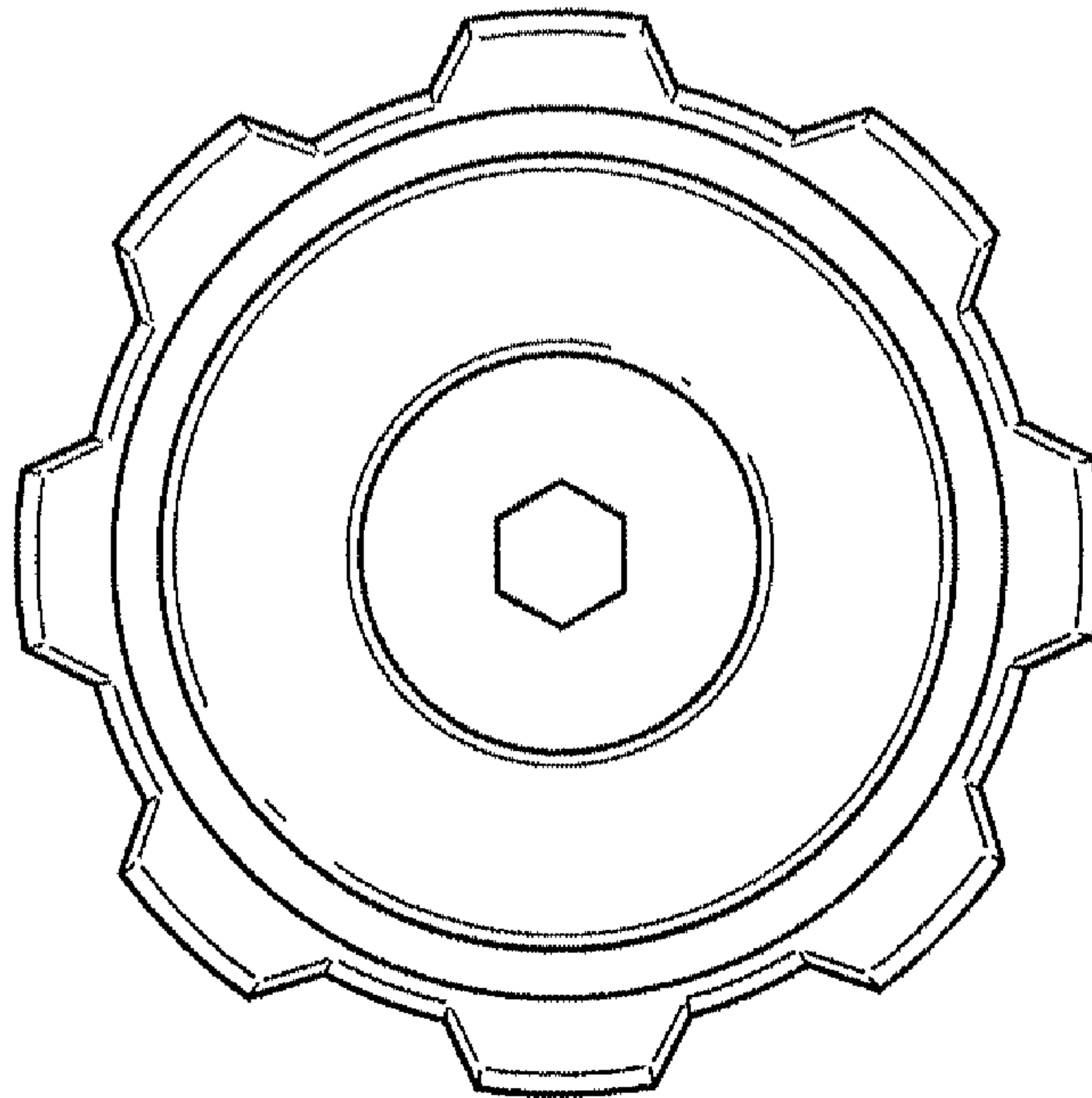

FIGURE 3