



US00D593272S

(12) **United States Design Patent**  
**Hailston**

(10) **Patent No.:** **US D593,272 S**

(45) **Date of Patent:** **\*\* May 26, 2009**

(54) **STRUCTURAL MEMBER FOR A HAND TRUCK OR CART**

(75) Inventor: **Bruce L. Hailston**, Midland, MI (US)

(73) Assignee: **Magline, Inc.**, Pinconning, MI (US)

(\*\*) Term: **14 Years**

(21) Appl. No.: **29/323,234**

(22) Filed: **Aug. 21, 2008**

(51) **LOC (9) Cl.** ..... **12-02**

(52) **U.S. Cl.** ..... **D34/27**

(58) **Field of Classification Search** ..... D34/27,  
D34/23; D12/133, 122; D25/119, 120, 121,  
D25/122, 123, 124, 125; 280/647, 47.27,  
280/47.28, 47.29; D23/266; 403/174, 191,  
403/245, 272; 414/445

See application file for complete search history.

D376,855 S *	12/1996	Leung	.....	D25/124
5,632,592 A	5/1997	Krawczyk		
5,913,527 A	6/1999	Hailston		
D412,141 S	7/1999	Dickie et al.		
D412,142 S	7/1999	Dickie		
D413,843 S	9/1999	Dickie		
D415,981 S	11/1999	Dickie		
D419,858 S *	2/2000	Bosgoed	.....	D8/377
D423,177 S	4/2000	Gaffney et al.		
D453,602 S *	2/2002	Chang	.....	D34/24
D465,634 S *	11/2002	Botzau et al.	.....	D34/24
D475,167 S	5/2003	Hailston		
6,921,095 B2 *	7/2005	Middleby	.....	280/47.29
D543,491 S *	5/2007	Weekes	.....	D12/106
D547,462 S *	7/2007	Petta et al.	.....	D25/122
D566,299 S *	4/2008	Mann	.....	D25/121
7,398,990 B2 *	7/2008	Tsai	.....	280/652
2004/0056438 A1 *	3/2004	Hailston	.....	280/47.27

\* cited by examiner

*Primary Examiner*—Cynthia E Ramirez

(74) *Attorney, Agent, or Firm*—Reising Ethington P.C.

(56) **References Cited**

U.S. PATENT DOCUMENTS

D189,447 S *	12/1960	Attwood	.....	D25/121
D210,872 S *	4/1968	Marsh	.....	D25/122
D219,877 S *	2/1971	Thompson	.....	D25/122
D225,219 S *	11/1972	Dallaire	.....	D25/119
3,997,182 A	12/1976	Mortenson		
D243,730 S *	3/1977	Koenig et al.	.....	D6/449
D249,031 S *	8/1978	Tarran	.....	D34/14
D249,032 S *	8/1978	Tarran	.....	D34/14
4,121,855 A	10/1978	Mortenson		
D251,451 S *	3/1979	Toder	.....	D25/121
4,275,894 A	6/1981	Mortenson		
4,563,014 A	1/1986	Mortenson		
D290,404 S *	6/1987	Stoler	.....	D25/119
4,762,333 A	8/1988	Mortenson		
4,790,547 A	12/1988	Mortenson		
4,893,824 A *	1/1990	Turek et al.	.....	280/47.27
D330,959 S *	11/1992	Apter et al.	.....	D34/26
5,326,116 A *	7/1994	Flax	.....	280/47.371
5,393,081 A	2/1995	Mortenson		
D358,982 S	6/1995	Bosgoed		
D371,612 S *	7/1996	Hsiao	.....	D25/124

(57) **CLAIM**

The ornamental design for a structural member for a hand truck or cart, as shown and described.

**DESCRIPTION**

FIG. 1 is a perspective view of a structural member for a hand truck or cart showing my new design, the broken line illustration of the other components of the hand truck are for illustrative purposes only and form no part of the claimed design;

FIG. 2 is an end view of the structural member, the opposite end being a mirror image of that shown;

FIG. 3 is a front view of the structural member;

FIG. 4 is a side view of the structural member, the opposite side view being a mirror image of that shown;

FIG. 5 is a rear view of the structural member; and,

FIG. 6 is a perspective view of the structural member.

**1 Claim, 2 Drawing Sheets**

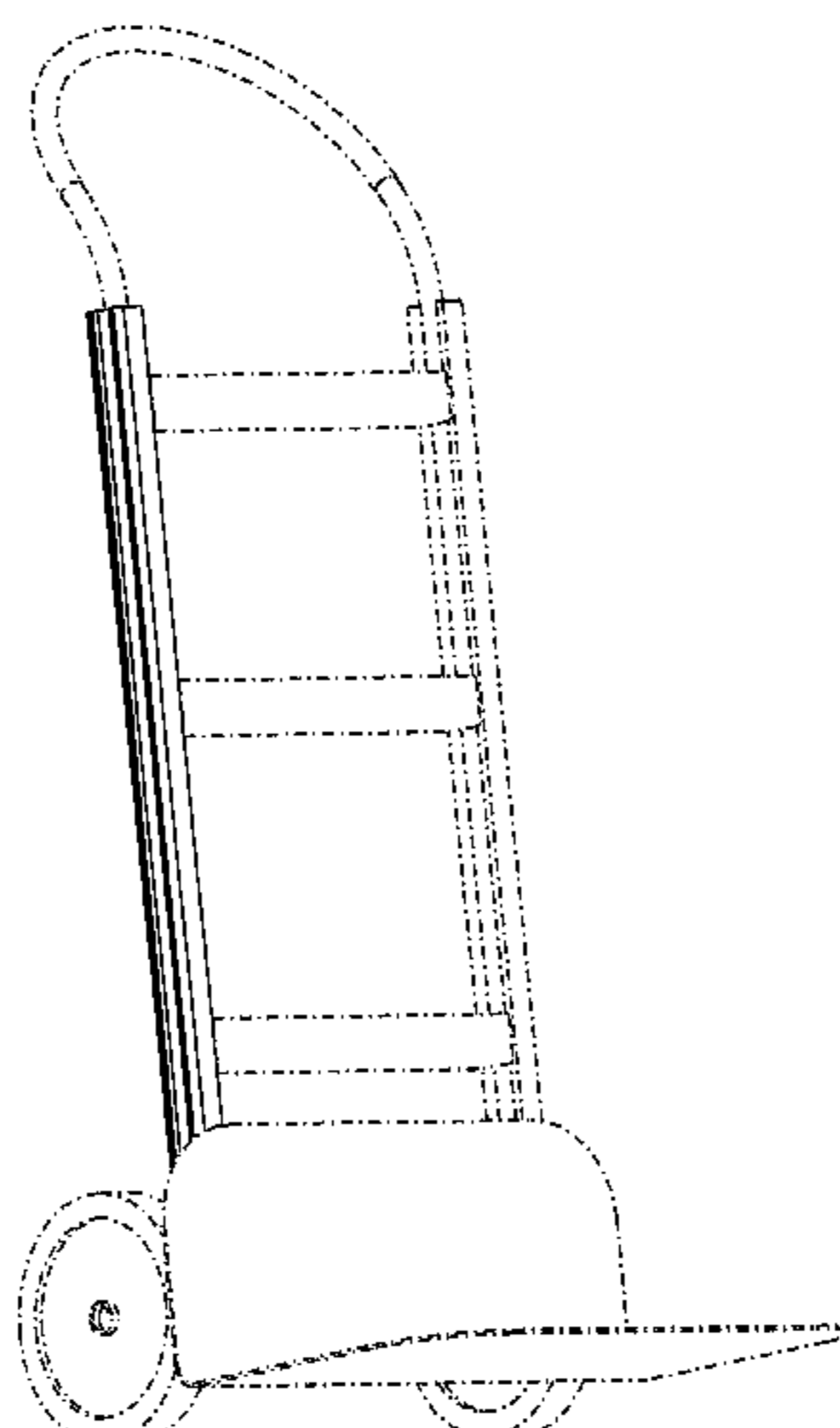

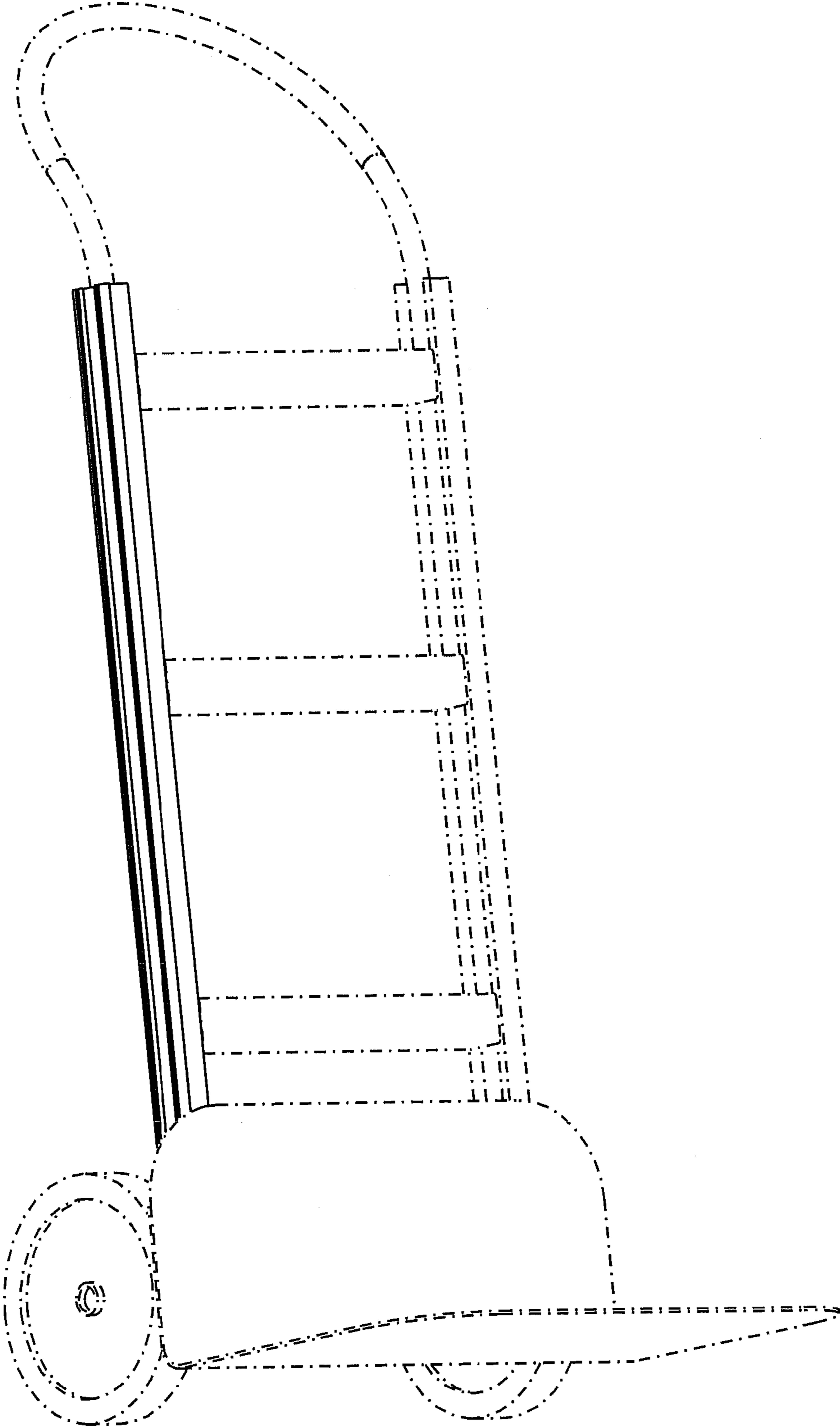

FIG. 1

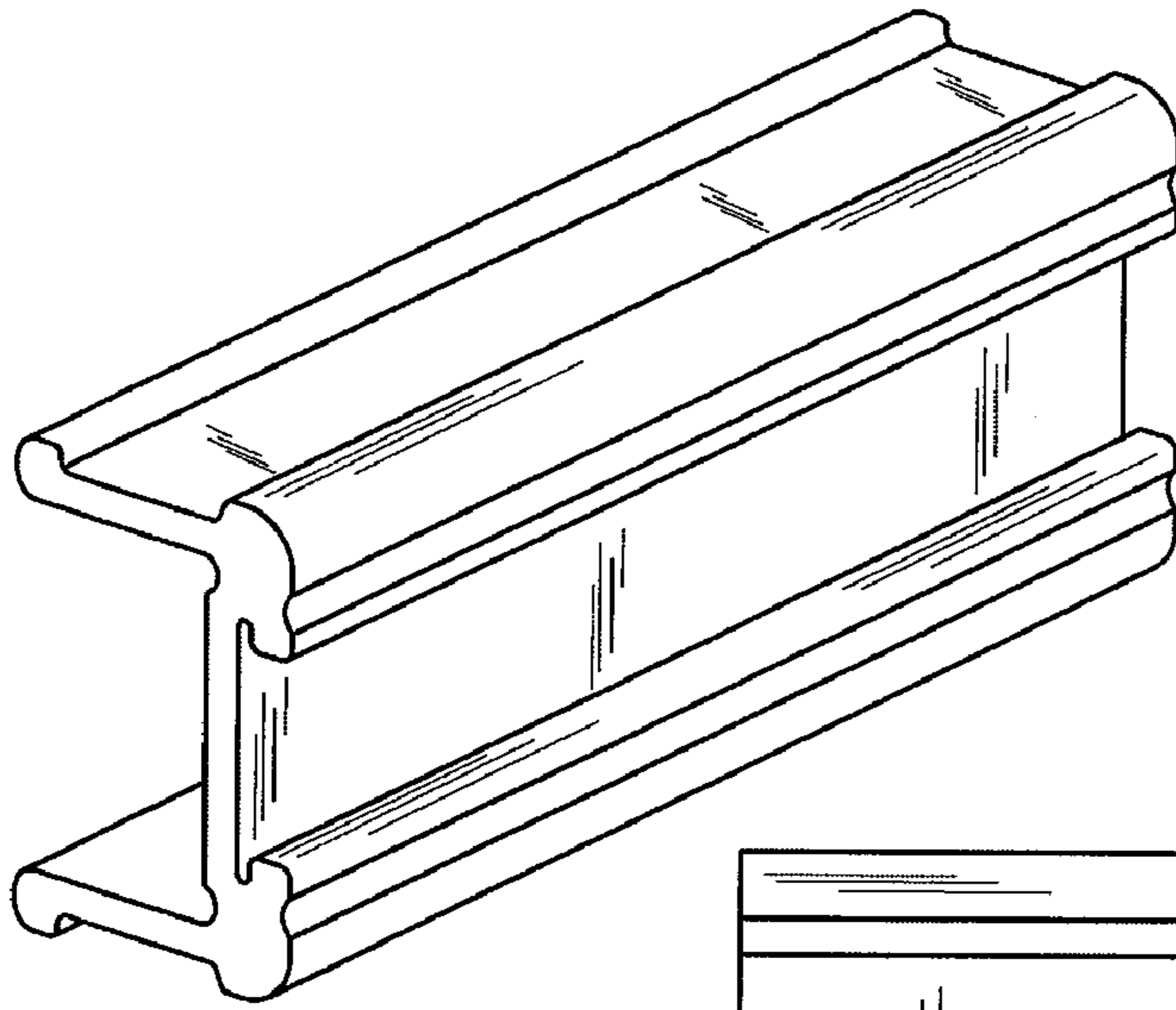

FIG. 6

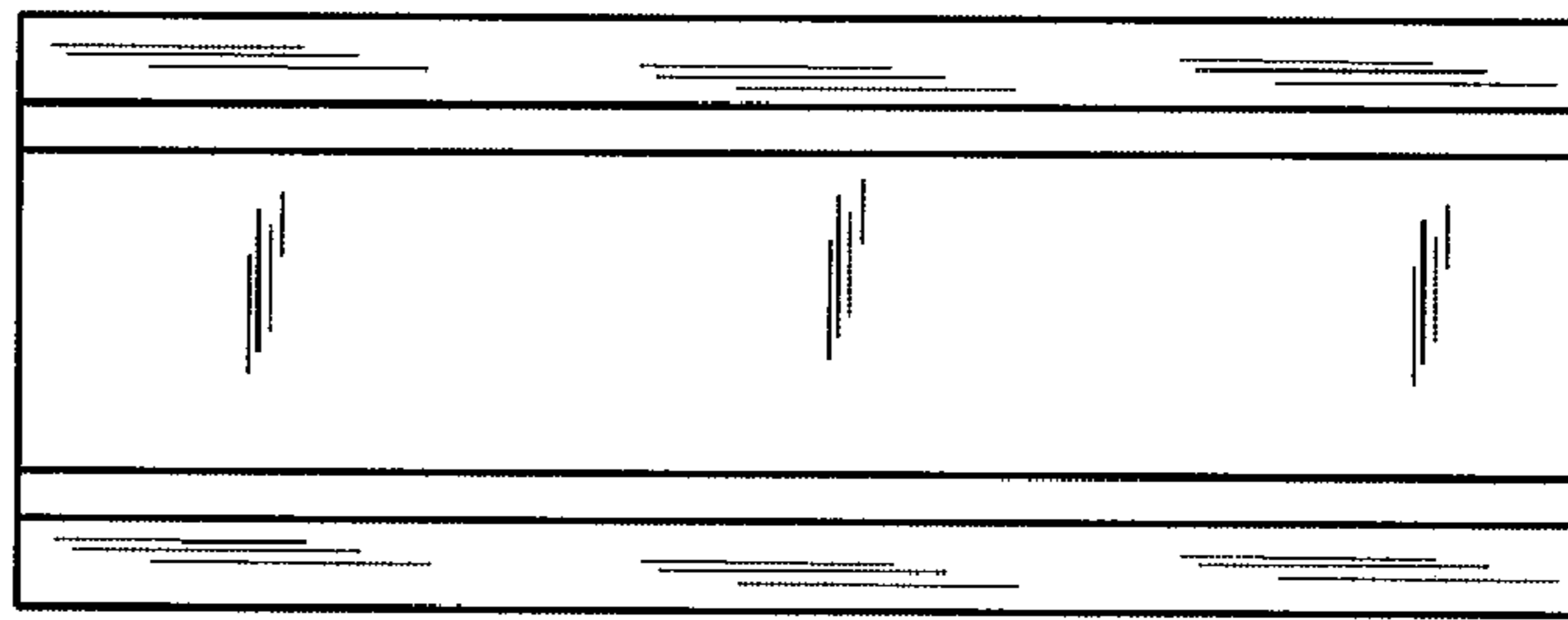

FIG. 5

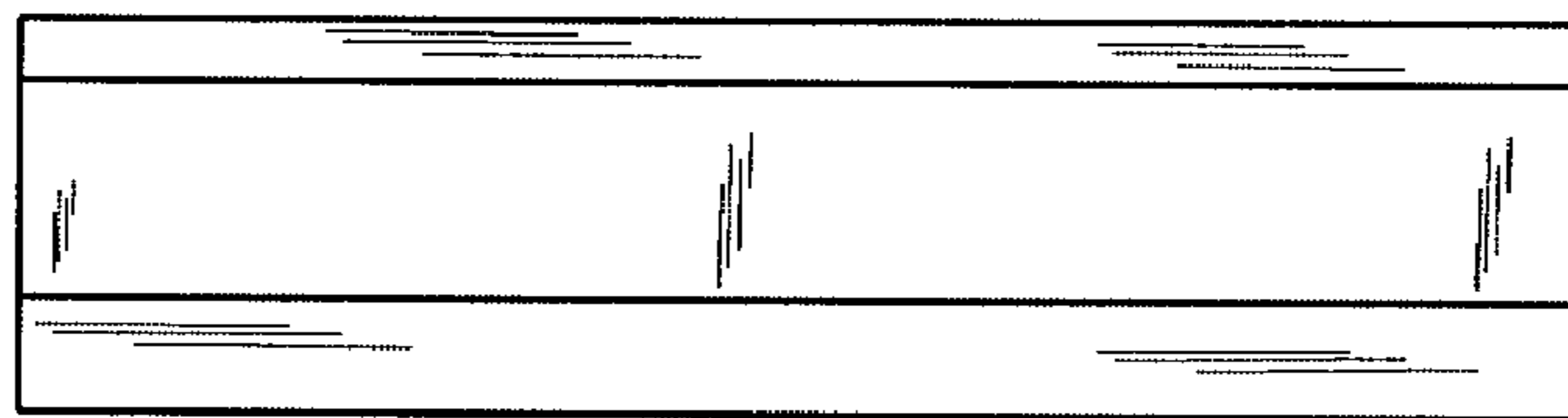

FIG. 4

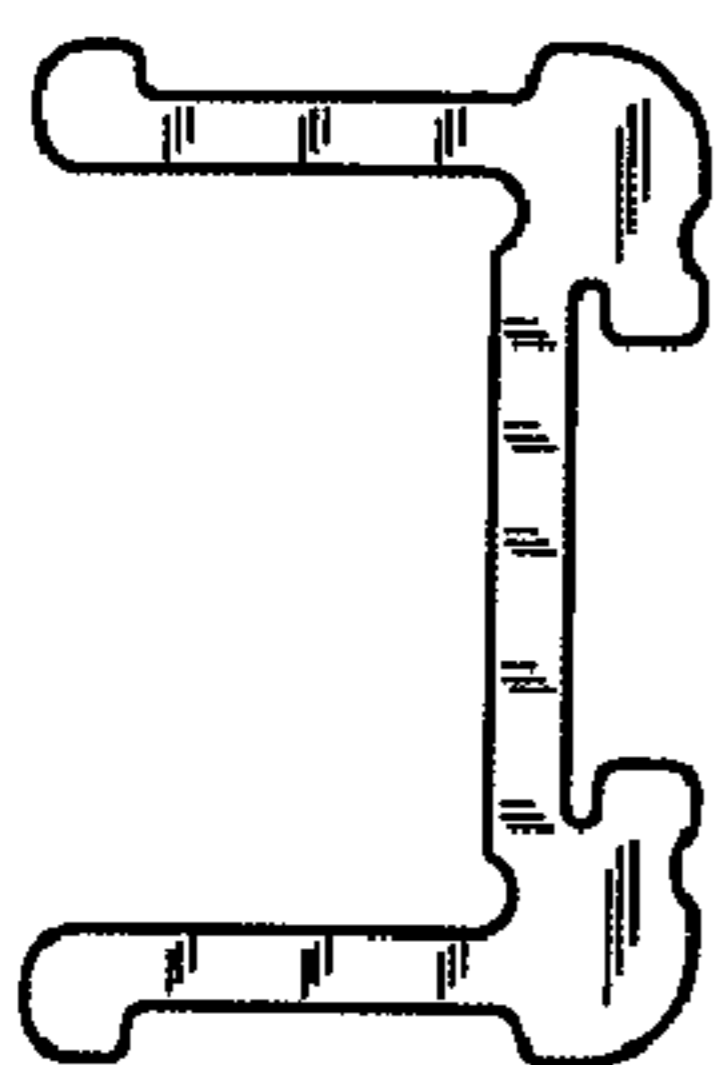

FIG. 2

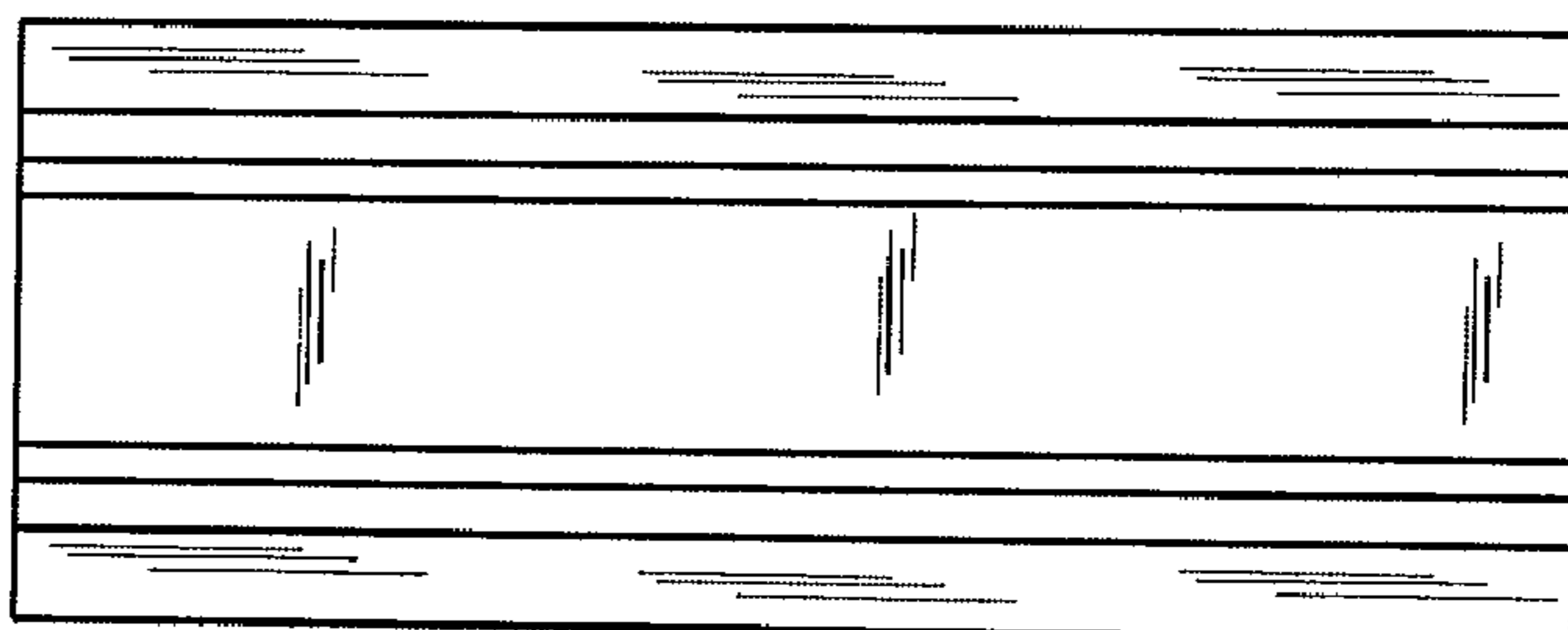

FIG. 3