

US00D593030S

(12) **United States Design Patent**  
**Konoma et al.**

(10) **Patent No.:** **US D593,030 S**  
(45) **Date of Patent:** **\*\* May 26, 2009**

(54) **DC TO AC POWER INVERTER FOR A VEHICLE ELECTRICAL SYSTEM**

D426,810 S \* 6/2000 Wei ..... D13/110  
D427,146 S \* 6/2000 Wei ..... D13/110  
D427,147 S \* 6/2000 Wei ..... D13/110  
D427,148 S \* 6/2000 Wei ..... D13/110

(75) Inventors: **Takaaki Konoma**, Kariya (JP);  
**Toshihiko Tsuzuki**, Kariya (JP)

\* cited by examiner

(73) Assignee: **Kabushiki Kaisha Toyota Jidoshokki**,  
Kariya-shi (JP)

*Primary Examiner*—Prabhakar Deshmukh

*Assistant Examiner*—Derrick Holland

(74) *Attorney, Agent, or Firm*—Morgan & Finnegan, LLP

(\*\*) Term: **14 Years**

(21) Appl. No.: **29/307,534**

(57) **CLAIM**

(22) Filed: **Apr. 24, 2008**

The ornamental design for a DC to AC power inverter for a vehicle electrical system, as shown.

(30) **Foreign Application Priority Data**

Oct. 25, 2007 (JP) ..... 2007-029318

**DESCRIPTION**

(51) **LOC (9) Cl.** ..... **13-02**

FIG. 1 is a front perspective view of a DC to AC power inverter for a vehicle electrical system showing our new design;

(52) **U.S. Cl.** ..... **D13/110**

FIG. 2 is a rear perspective view thereof;

(58) **Field of Classification Search** ..... D13/110,  
D13/123, 184, 199; 337/186; 361/600, 601,  
361/730; 363/141, 142

FIG. 3 is a front view thereof;

FIG. 4 is a rear view thereof;

See application file for complete search history.

FIG. 5 is a top plan view thereof;

FIG. 6 is a bottom plan view thereof;

(56) **References Cited**

**U.S. PATENT DOCUMENTS**

4,872,102 A \* 10/1989 Getter ..... 363/141  
5,170,336 A \* 12/1992 Getter et al. .... 363/141  
D349,682 S \* 8/1994 Hunziker ..... D13/110  
D413,567 S \* 9/1999 Person et al. .... D13/110  
5,949,640 A \* 9/1999 Cameron et al. .... 361/600

FIG. 7 is a right side view thereof; and,

FIG. 8 is a left side view thereof.

The broken lines showing of environment is for illustrative purpose only and forms no part of the claimed design.

**1 Claim, 6 Drawing Sheets**

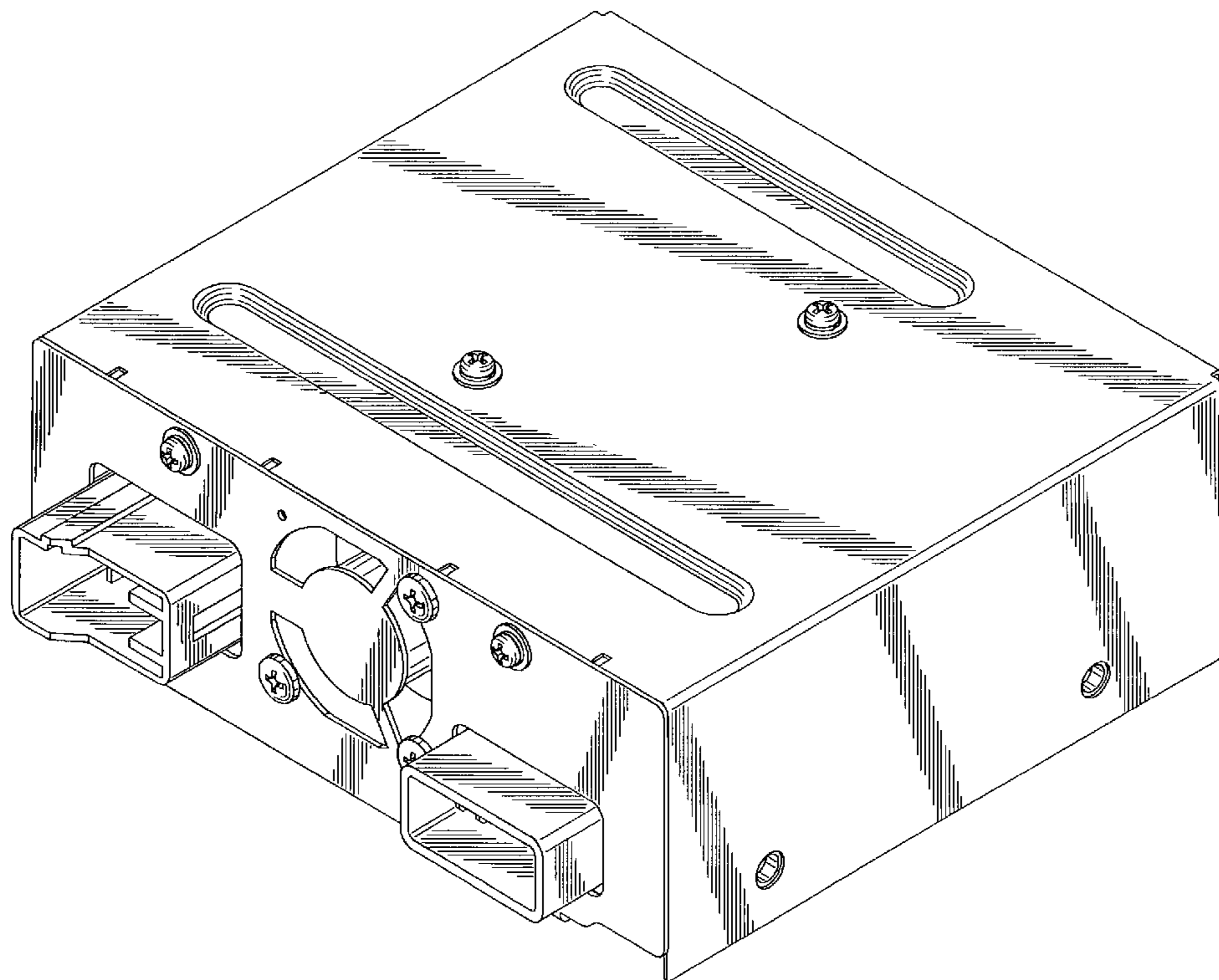

FIG. 1

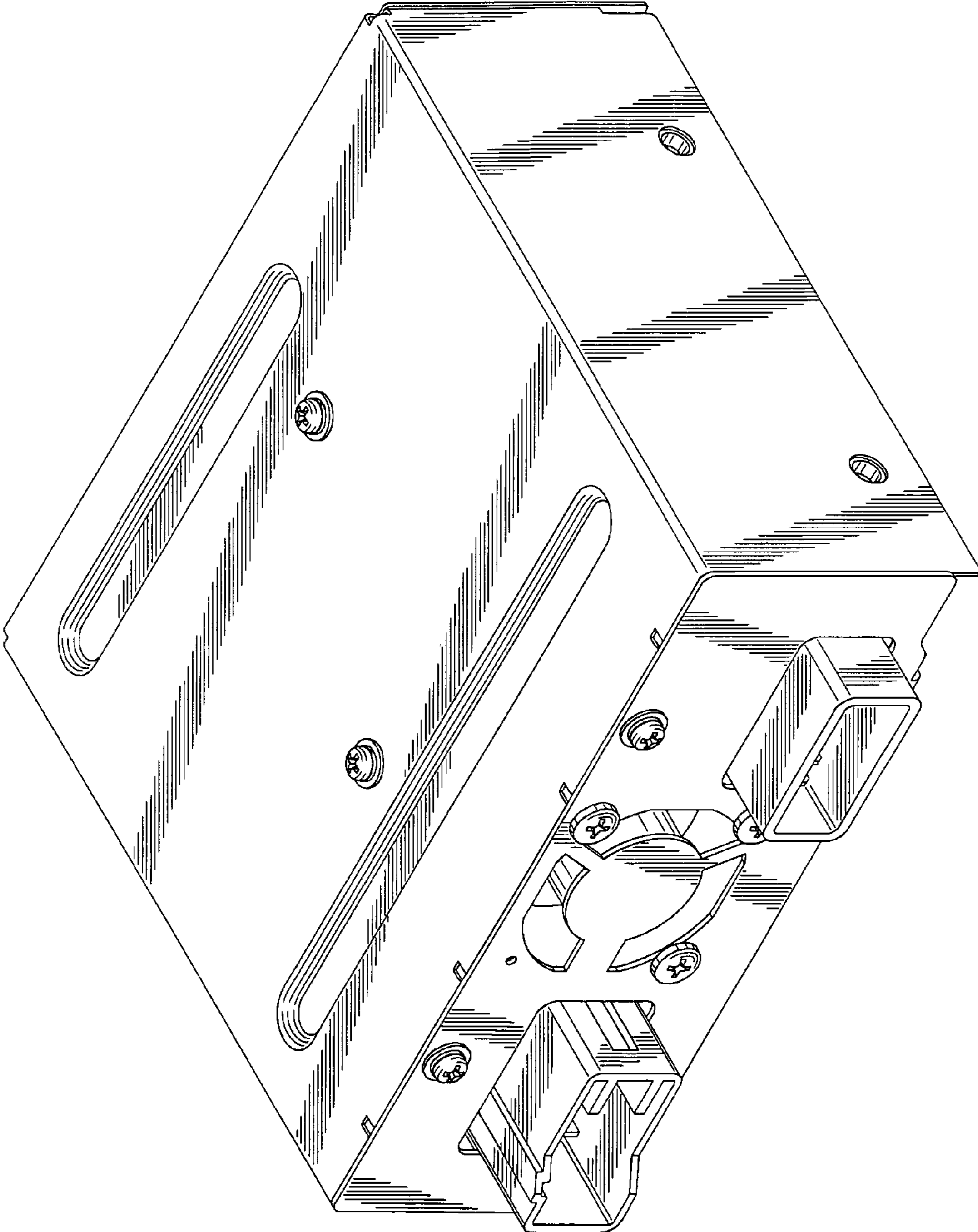
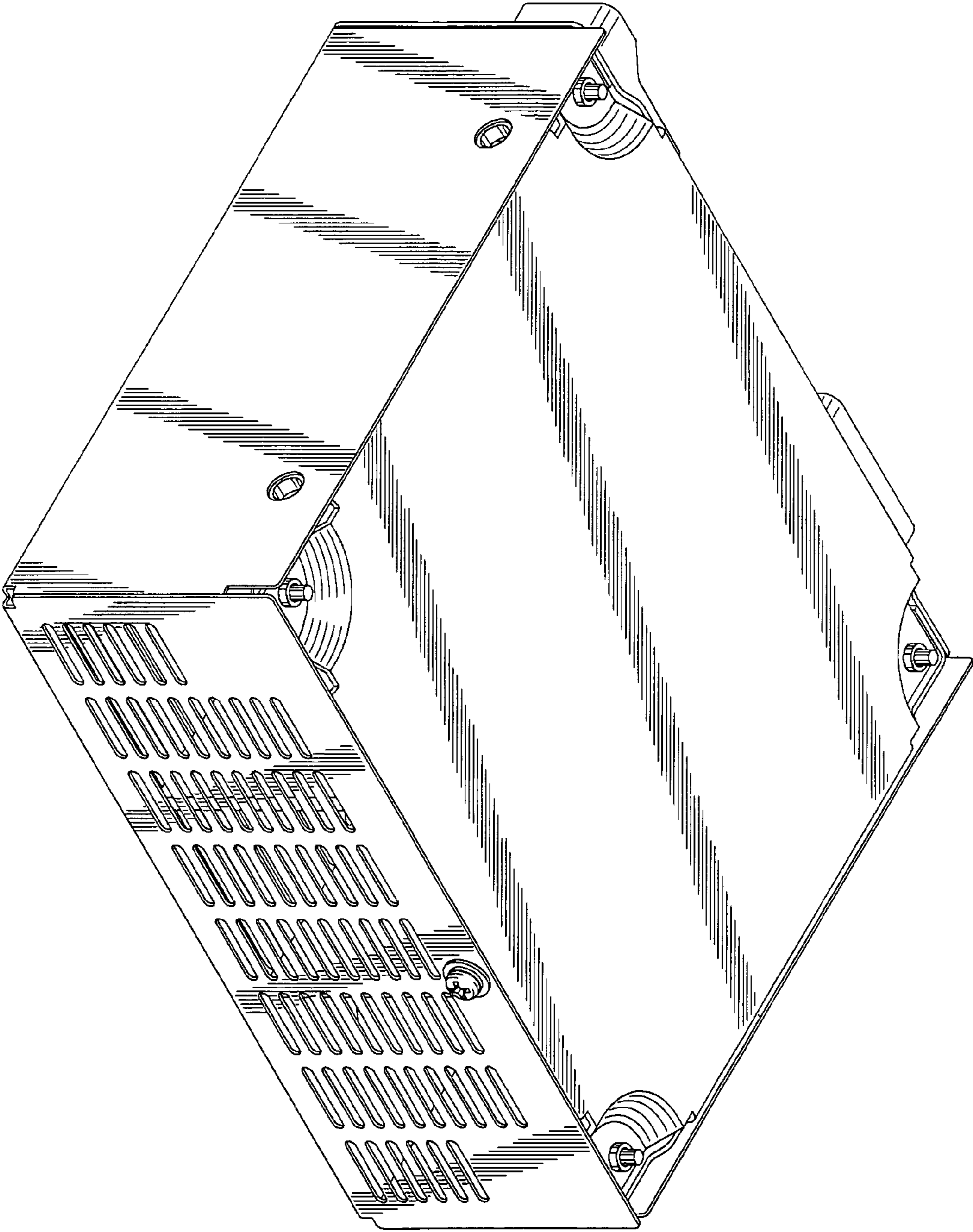
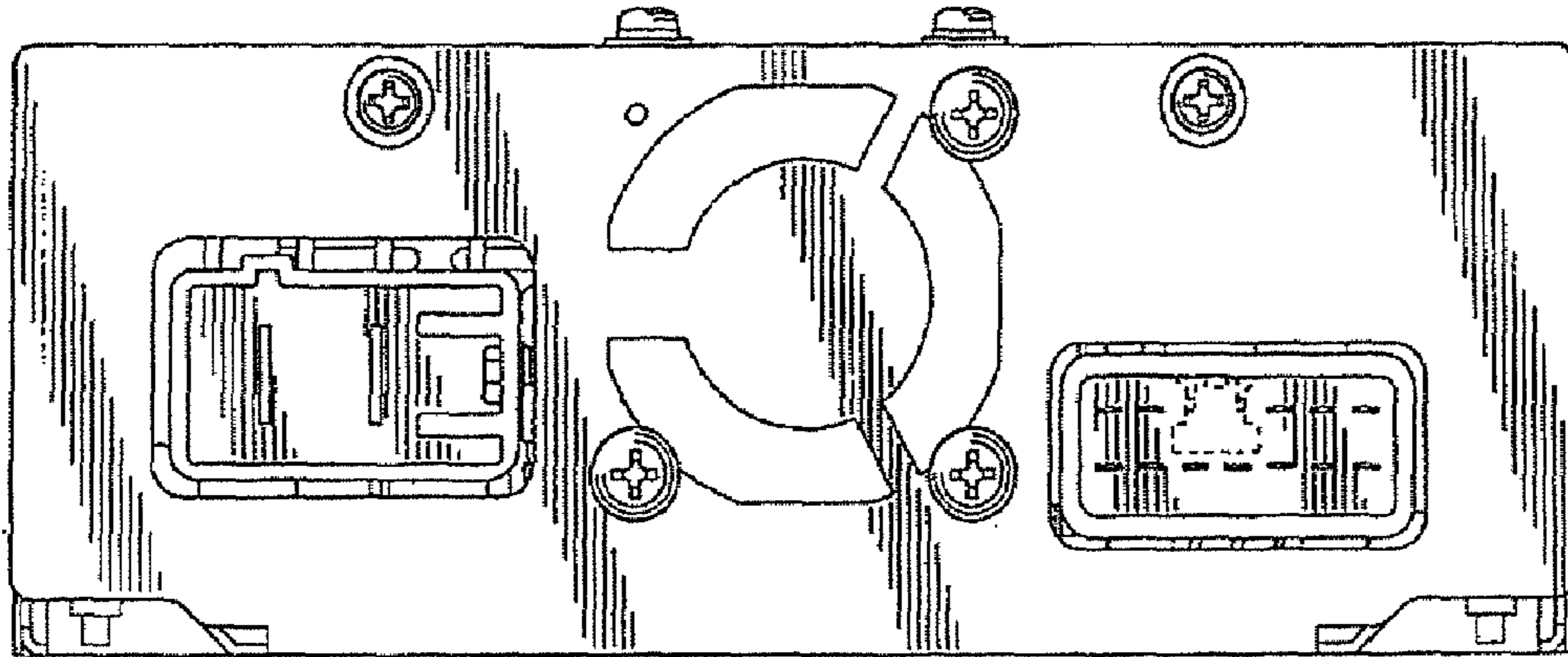

FIG. 2





**FIG. 3**



**FIG. 4**

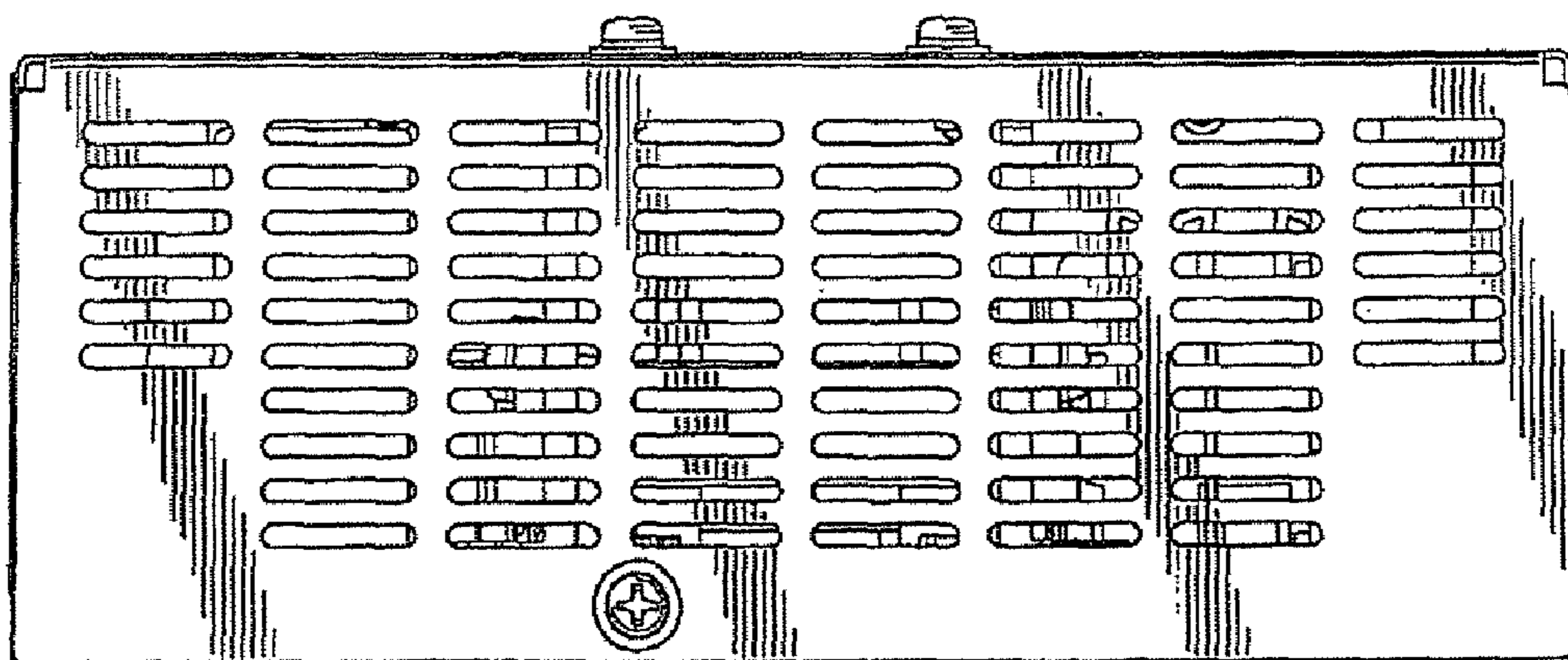

FIG. 5

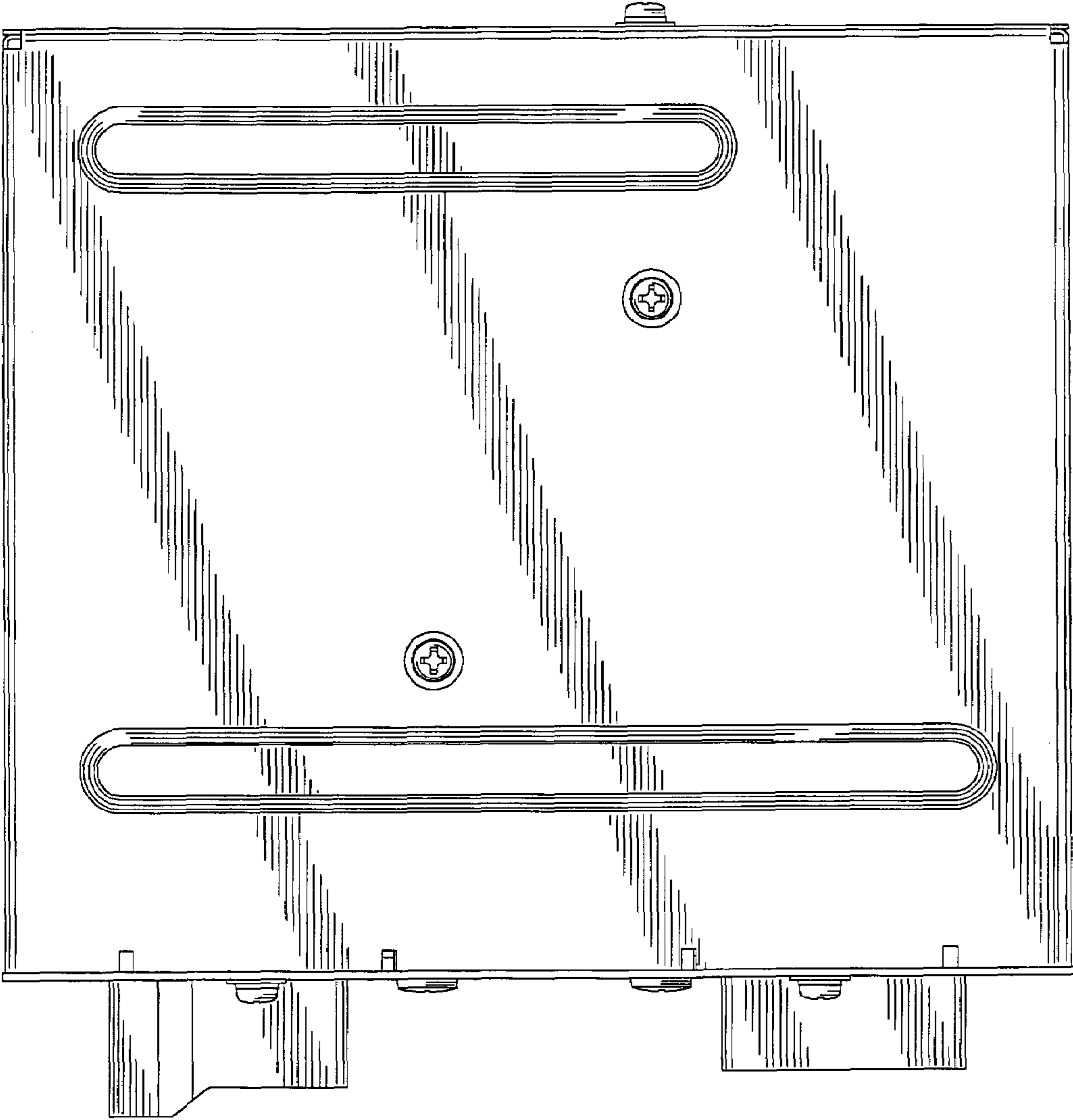

FIG. 6

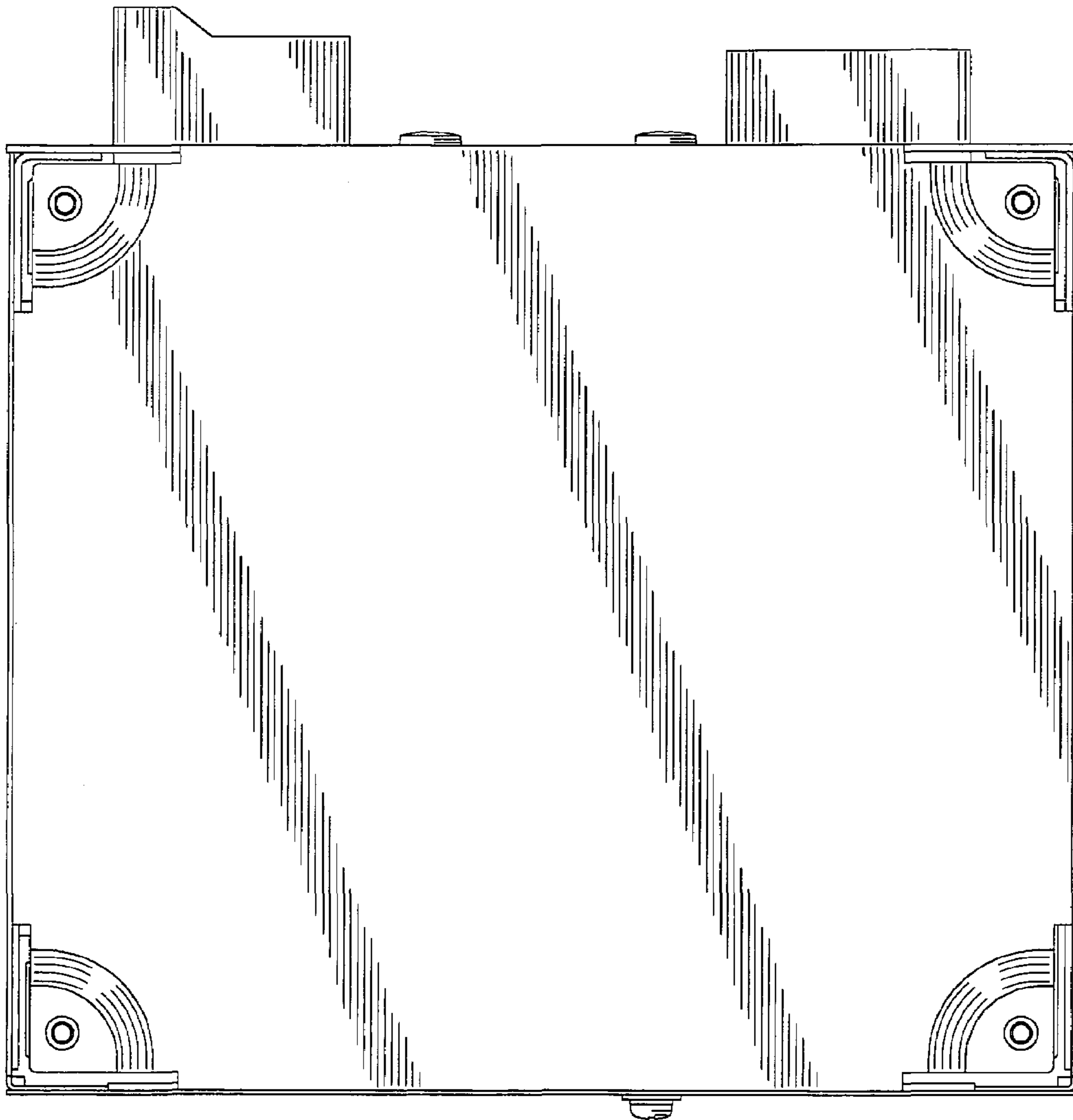

FIG. 7

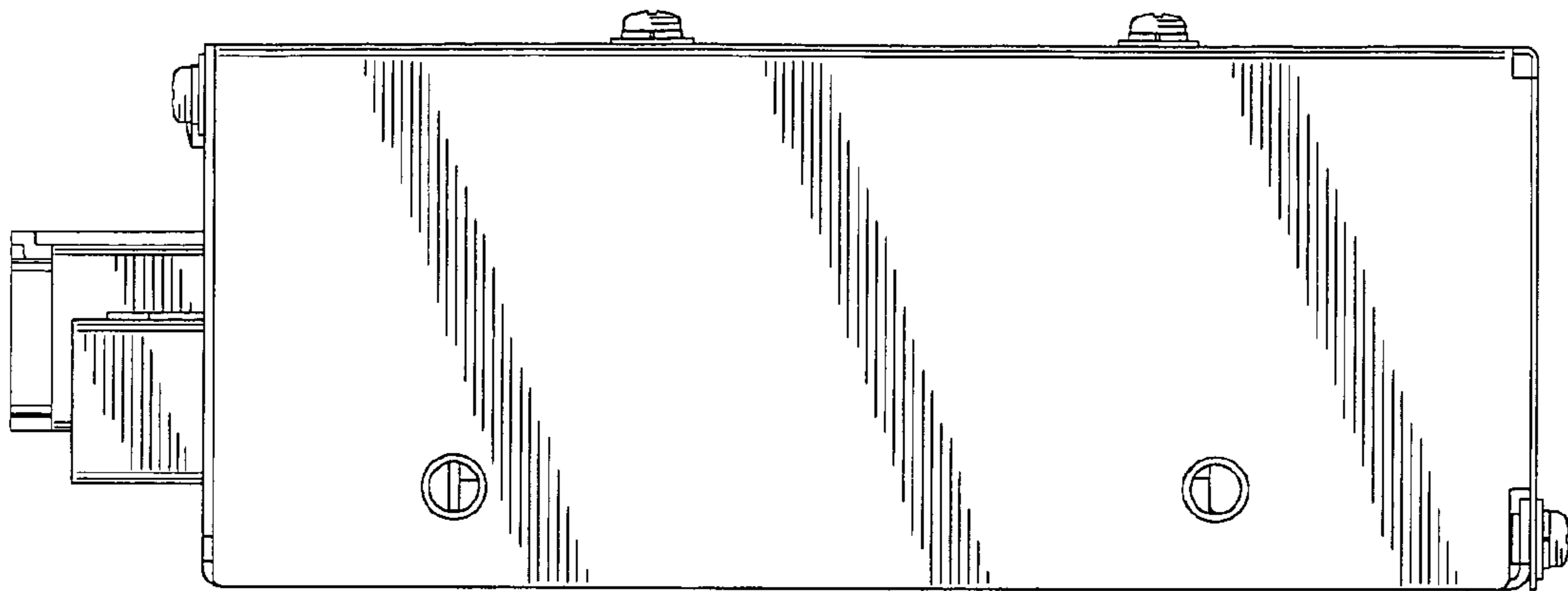

FIG. 8

