



US00D593014S

(12) **United States Design Patent**
Marovič

(10) **Patent No.:** **US D593,014 S**

(45) **Date of Patent:** **** May 26, 2009**

(54) **MOTORCYCLE EXHAUST ELEMENT**

(57) **CLAIM**

(76) Inventor: **Gorazd Marovič**, Kokolova 4, Ptuj (SI)
2250

The ornamental design for a motorcycle exhaust element,
substantially as shown and described.

(**) Term: **14 Years**

DESCRIPTION

(21) Appl. No.: **29/297,109**

(22) Filed: **Nov. 5, 2007**

(51) **LOC (9) Cl.** **12-16**

(52) **U.S. Cl.** **D12/194**

(58) **Field of Classification Search** D12/110,
D12/194; 180/89.2, 219, 225, 296, 309;
181/227, 228, 247–251, 255, 264, 238, 282,
181/211, 212, 239, 241, 262, 263, 259, 260,
181/243; 29/39.04, 39.5, 282, 890.08; 60/313,
60/323, 299, 302; D15/5; D25/152–164,
D25/119, 124, 42–44; D8/376, 377; 52/74–78,
52/576, 831, 843; D7/672, 677; 426/496
See application file for complete search history.

FIG. 1 is a top view of the motorcycle exhaust element of the
present invention, in a first environment, showing an exhaust
tip cover that forms no part of the claimed design in broken
lines.

FIG. 2 is a bottom view of the motorcycle exhaust element of
FIG. 1.

FIG. 3 is a left side view of the motorcycle exhaust element of
FIG. 1.

FIG. 4 is a right side view of the motorcycle exhaust element
of FIG. 1.

FIG. 5 is a rear view of the motorcycle exhaust element of
FIG. 1.

FIG. 6 is a front view of the motorcycle exhaust element of
FIG. 1. The broken lines at the front edge of the motorcycle
exhaust element, where an exhaust pipe may attach, illustrate
a boundary line that forms no part of the claimed design.

FIG. 7 is a perspective view, from the top left side, of the
motorcycle exhaust element of the present invention, in
another environment, with portions shown in broken lines
forming no part of the claimed design.

FIG. 8 is a perspective view, from the bottom right side, of the
motorcycle exhaust element of the present invention in
another environment. The interior surfaces of the motorcycle
exhaust element form no part of the claimed design, and the
portions shown in broken lines form no part of the claimed
design.

FIG. 9 is a top view of the motorcycle exhaust element of the
present invention, in another environment, showing an
exhaust tip that forms no part of the claimed design in broken
lines.

FIG. 10 is a bottom view of the motorcycle exhaust element of
FIG. 9.

FIG. 11 is a left side view of the motorcycle exhaust element
of FIG. 9.

(56) **References Cited**

U.S. PATENT DOCUMENTS

7,464,787 B2 * 12/2008 Davis, Jr. 181/227

FOREIGN PATENT DOCUMENTS

SI	200550034	2/2006	12/16
SI	200550083	6/2006	12/16

OTHER PUBLICATIONS

Motopuls, magazine (Slovenia), No. 44, 5./6. 2003, p. 127.

Motopuls, magazine (Slovenia), No. 44, 5./6. 2003, p. 11.

* cited by examiner

Primary Examiner—Robin V Webster

Assistant Examiner—Linda Brooks

(74) *Attorney, Agent, or Firm*—Robert Platt Bell

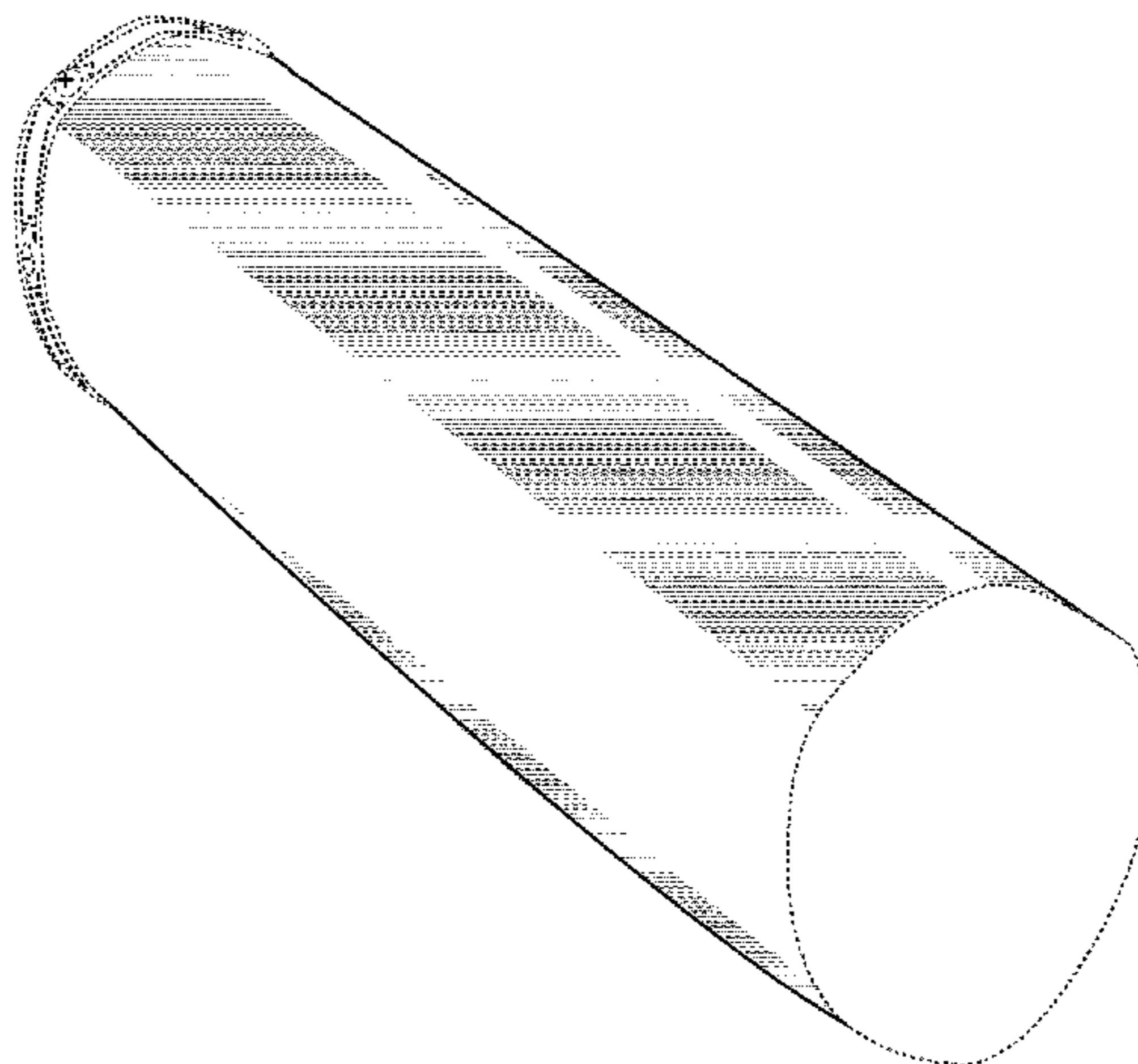

FIG. **12** is a right side view of the motorcycle exhaust element of FIG. **9**.

FIG. **13** is a rear view of the motorcycle exhaust element of FIG. **9**.

FIG. **14** is a front view of the motorcycle exhaust element of FIG. **9**. The broken lines at the front edge of the motorcycle exhaust element, where an exhaust pipe may attach, illustrate a boundary line that forms no part of the claimed design.

FIG. **15** is a perspective view, from the bottom left side, of the motorcycle exhaust element of the present invention in another environment. The interior surfaces of the motorcycle exhaust element form no part of the claimed design, and the

portions shown in broken lines form no part of the claimed design; and,

FIG. **16** is a perspective view, from the top right side, of the motorcycle exhaust element of the present invention in another environment, with portions shown in broken lines forming no part of the claimed design.

The exhaust tip and exhaust tip cover, along with the related mounting straps and fasteners, shown in broken lines in the drawings form no part of the claimed design. In addition, the broken lines at the front and rear of the motorcycle exhaust element form boundary lines.

1 Claim, 6 Drawing Sheets

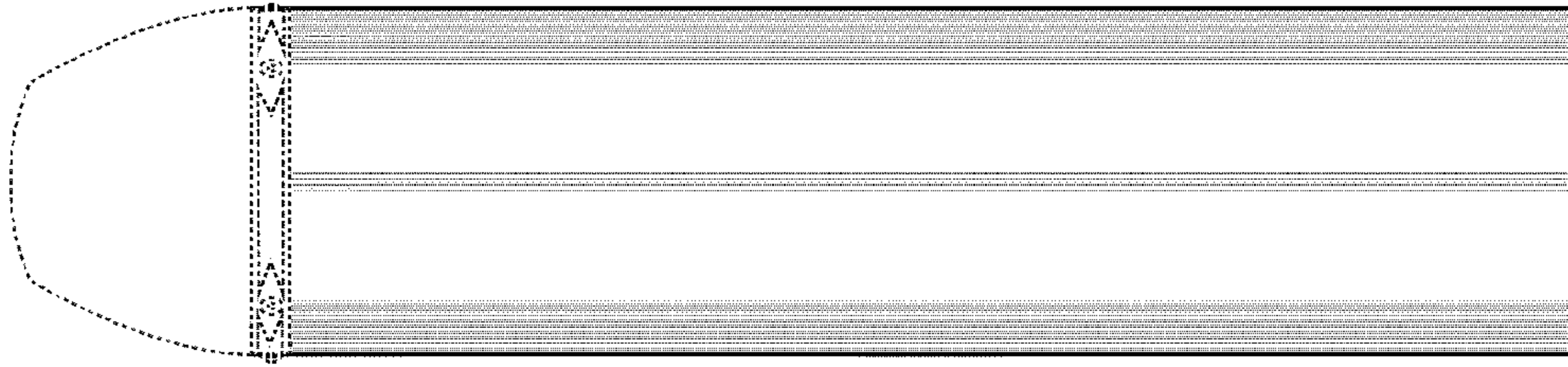

FIG. 1

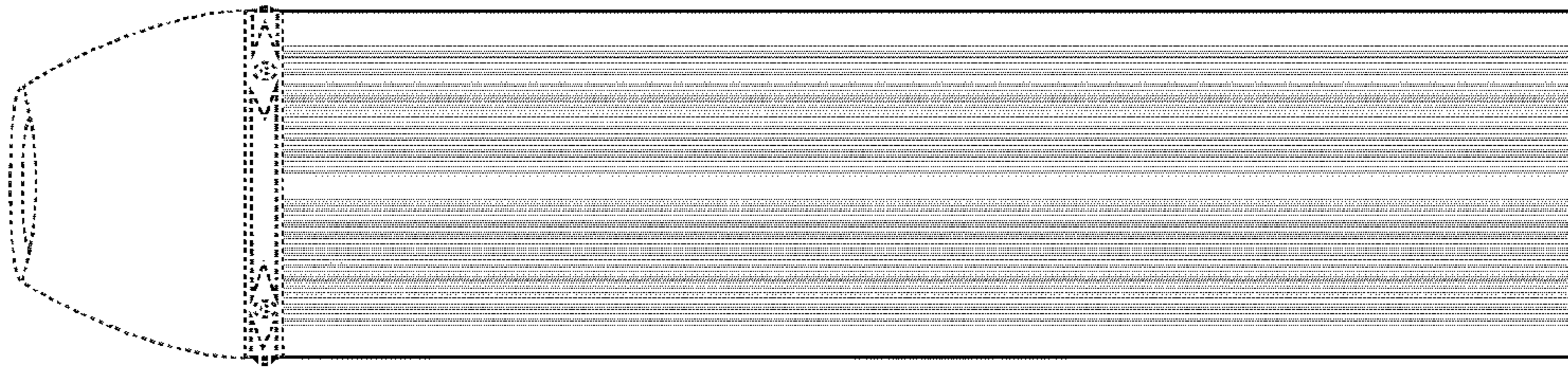

FIG. 2

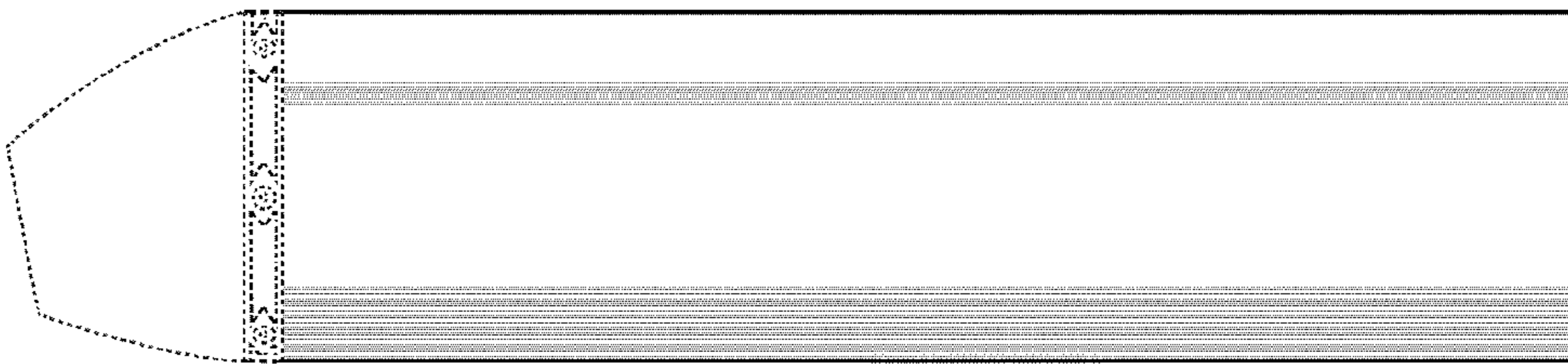

FIG. 3

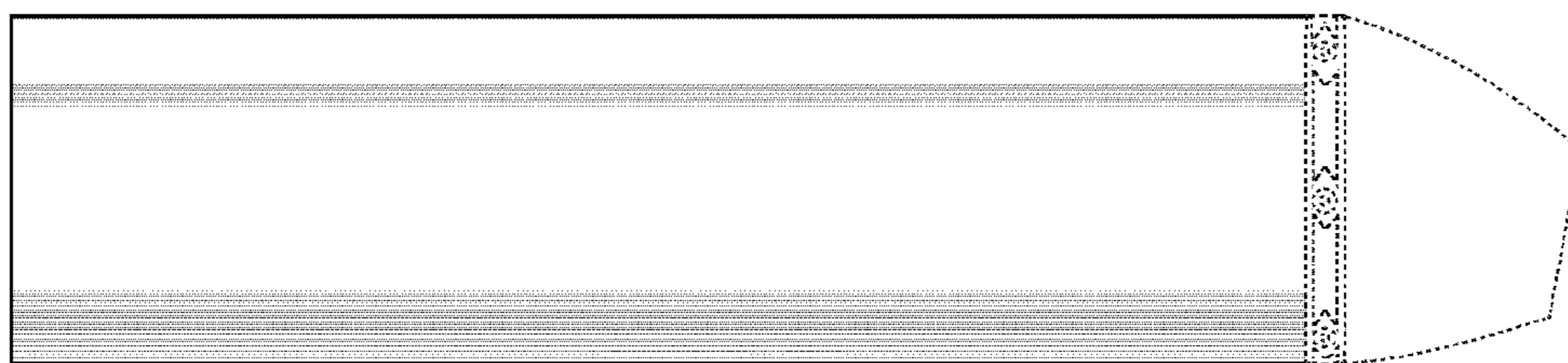

FIG. 4

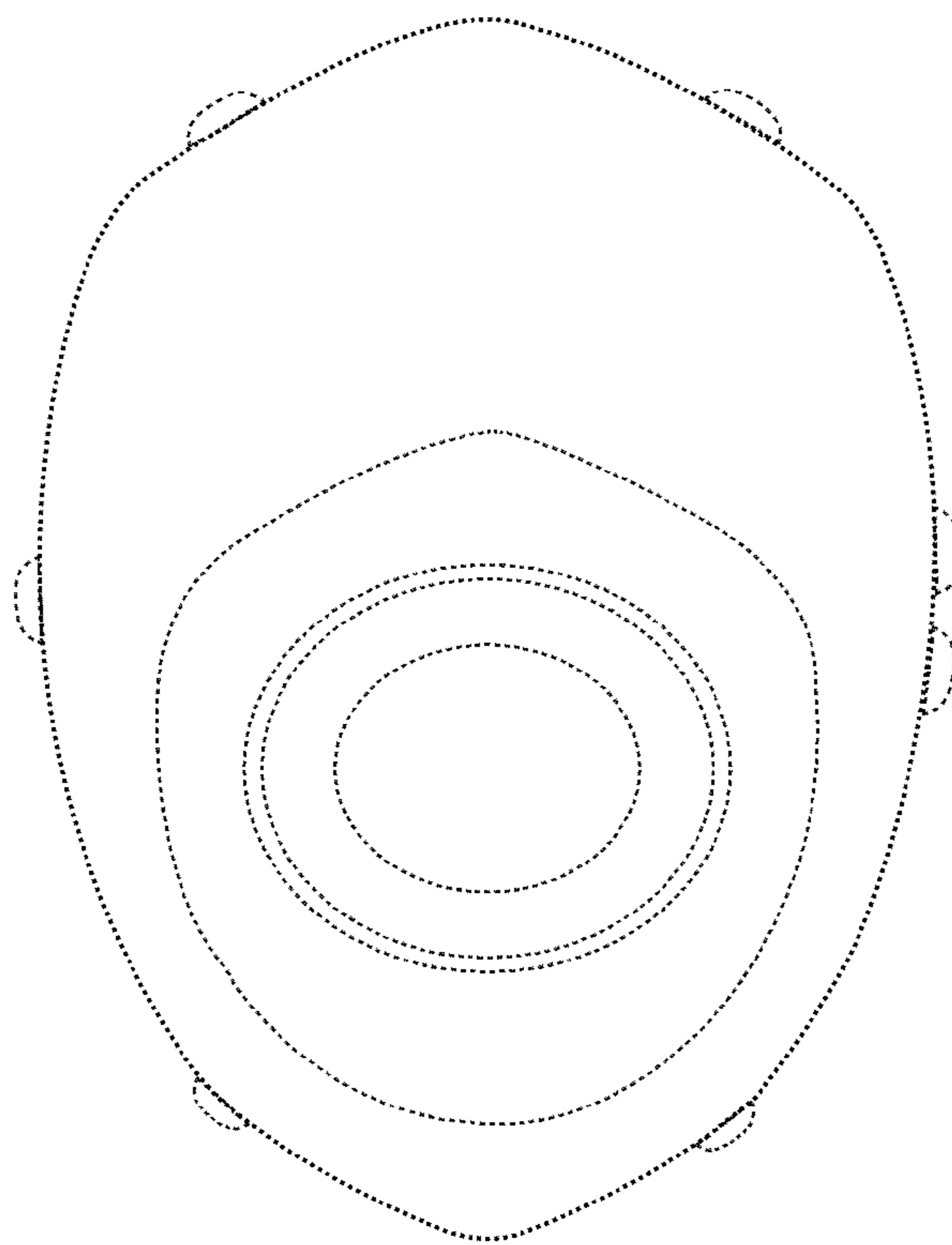

FIG. 5

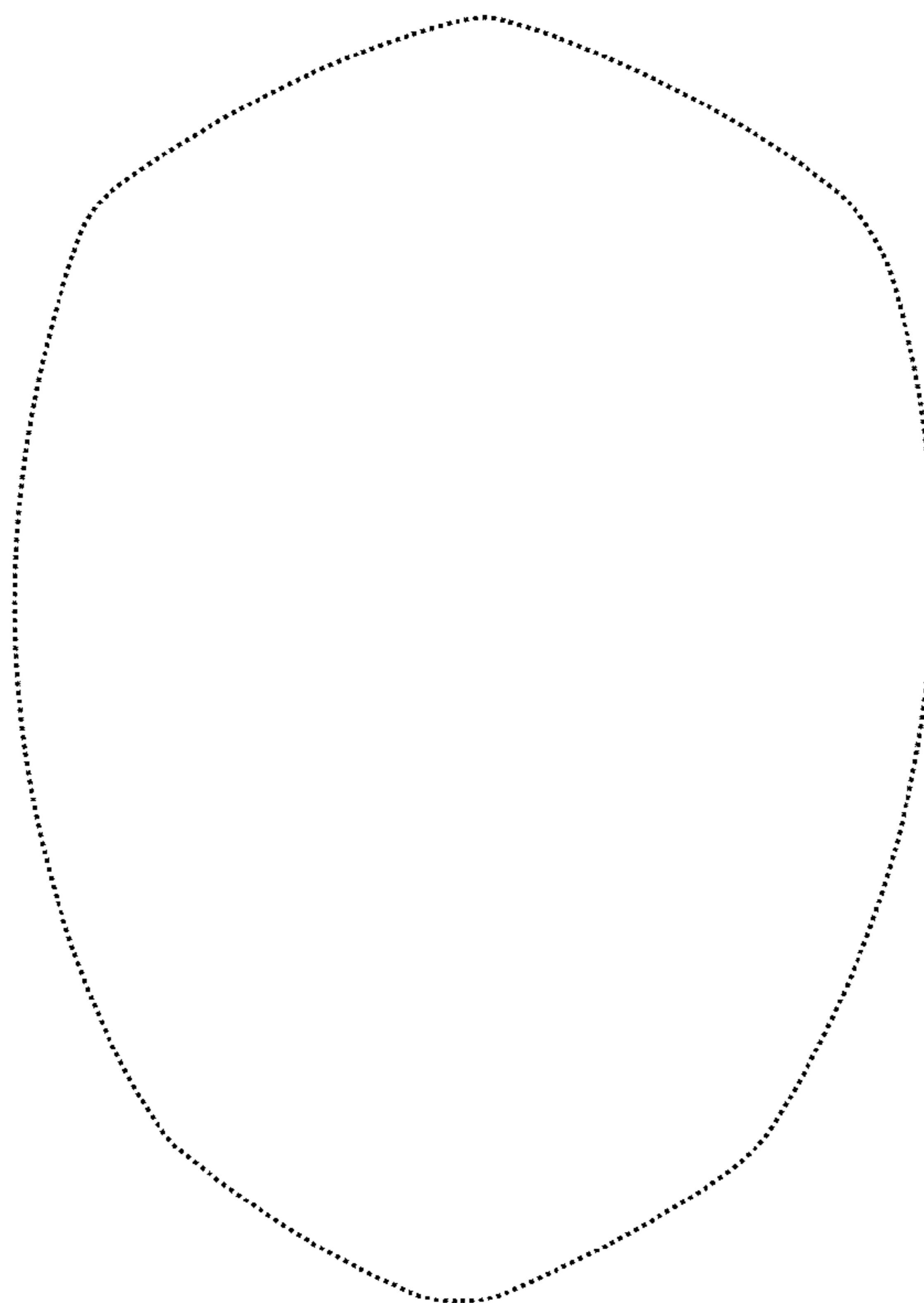

FIG. 6

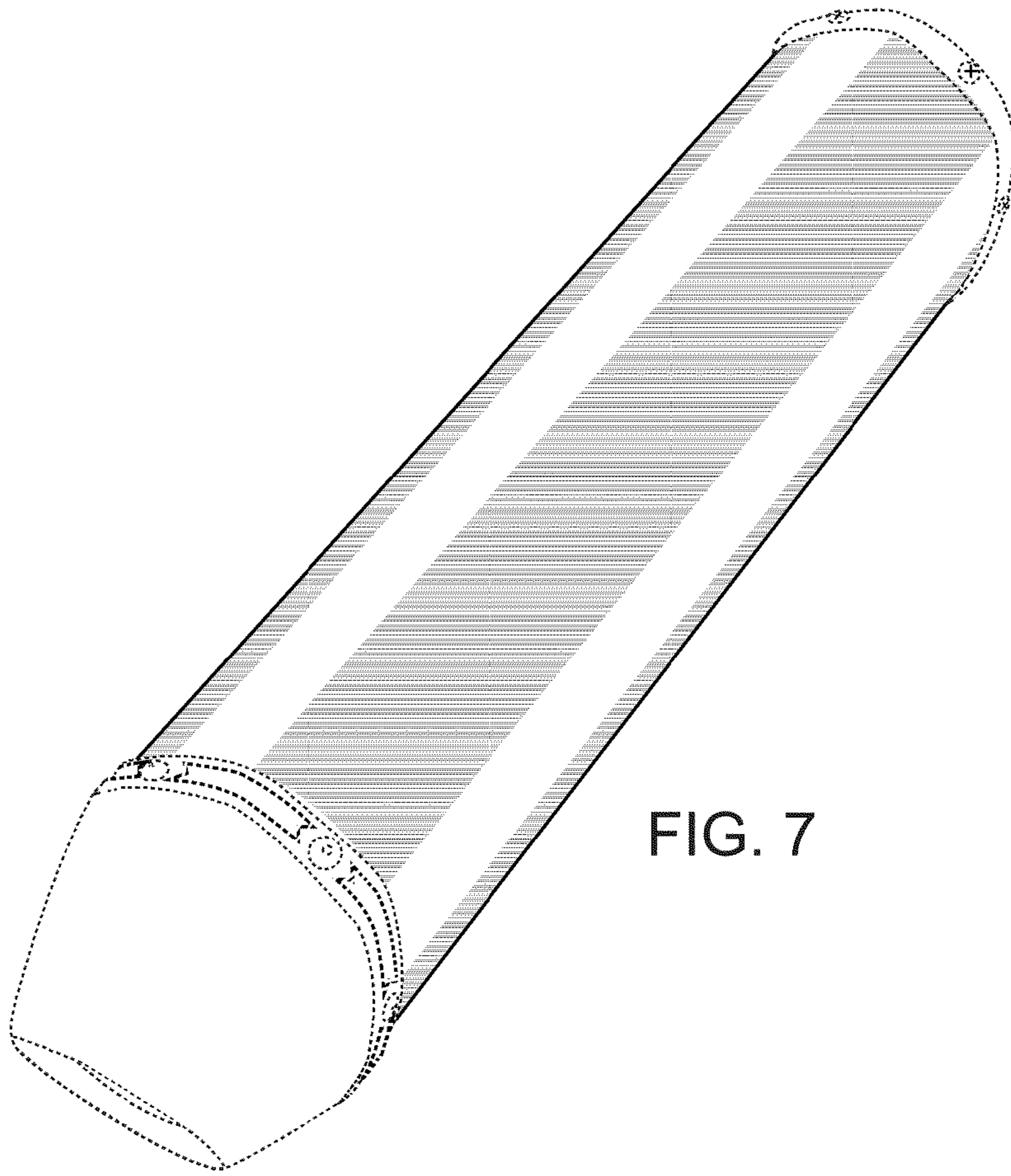

FIG. 7

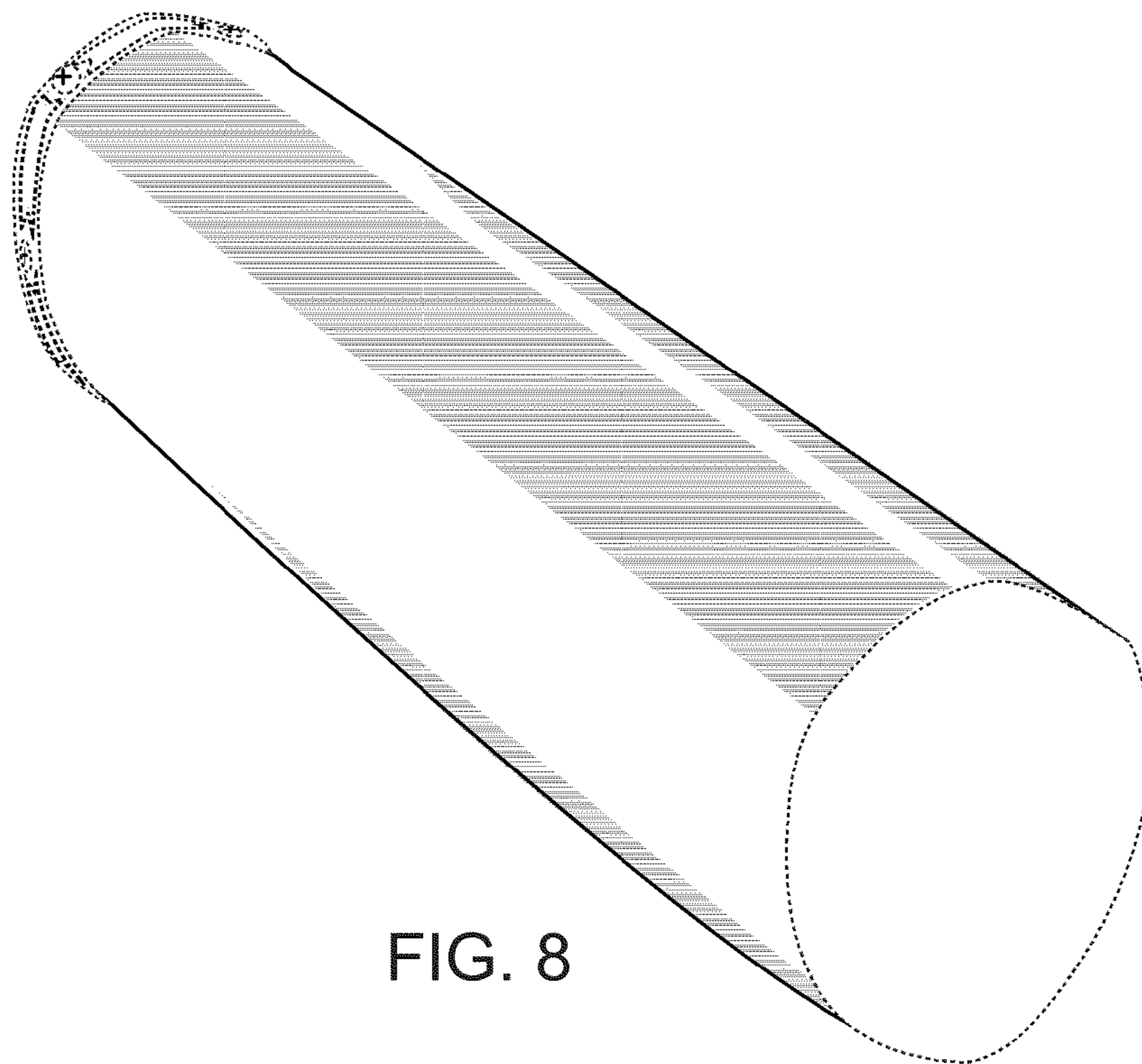

FIG. 8



FIG. 9

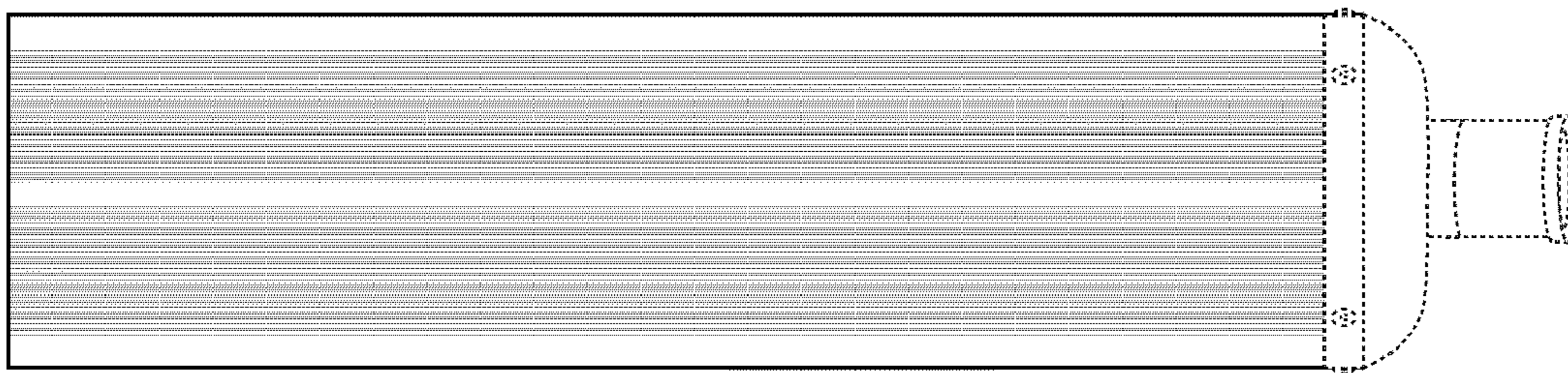

FIG. 10

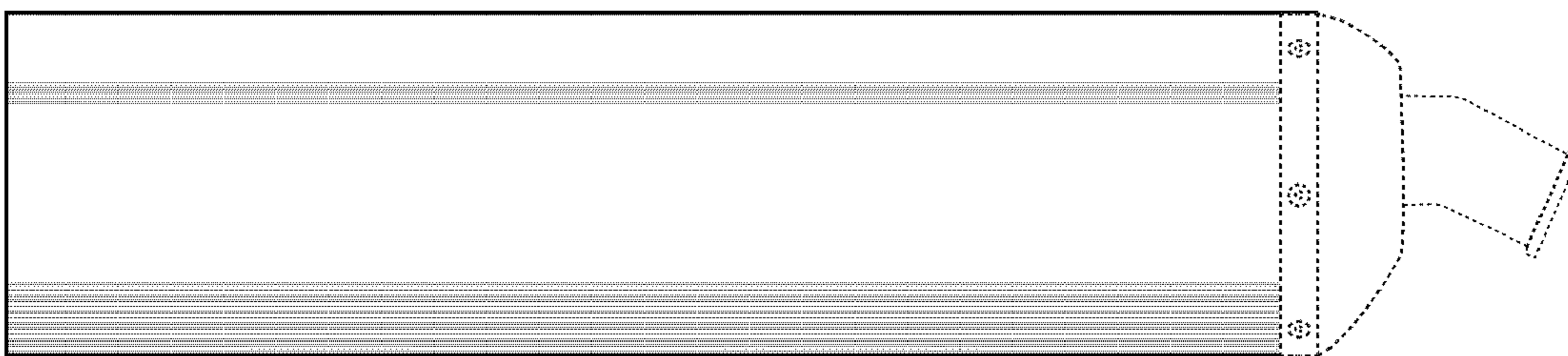

FIG. 11



FIG. 12

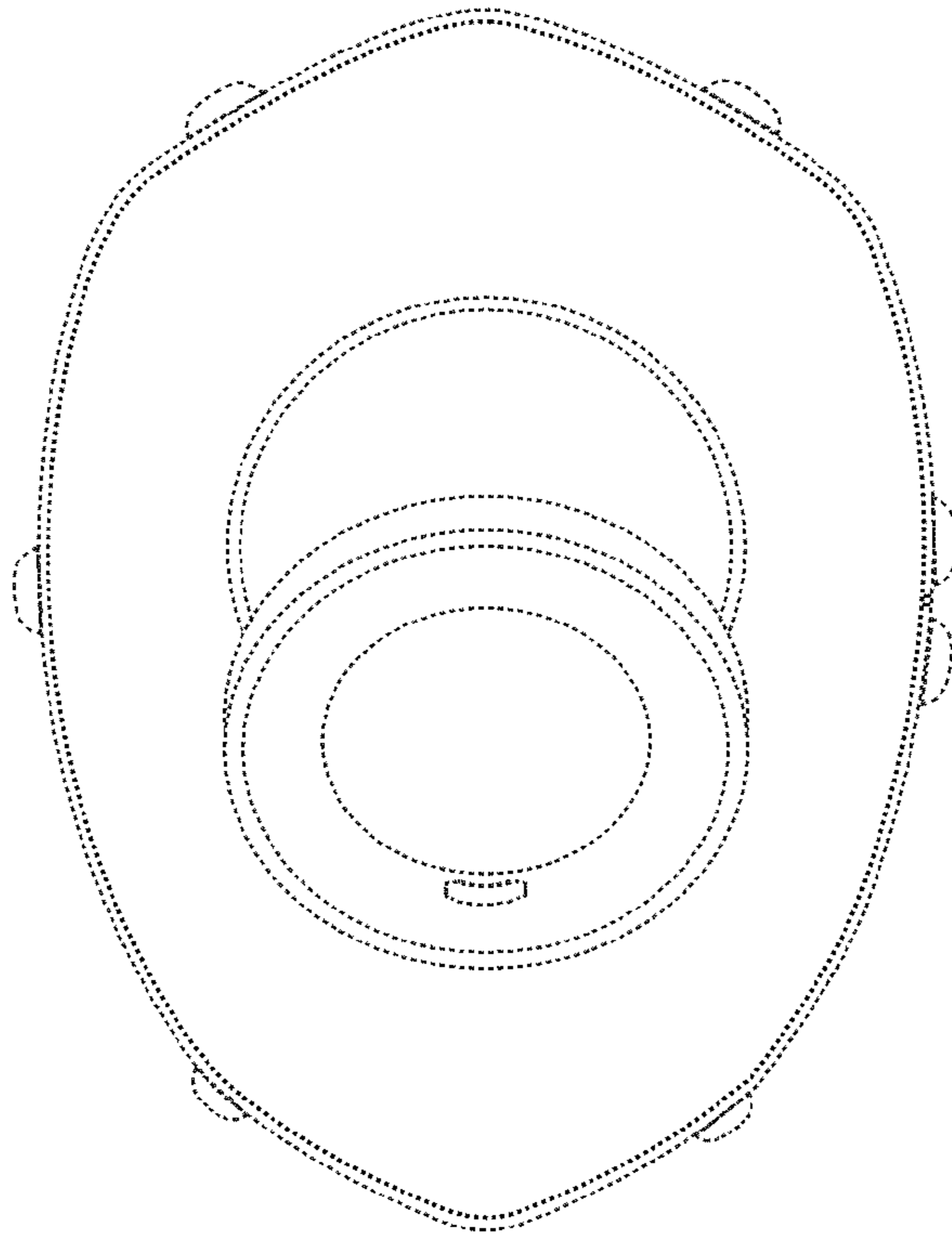

FIG. 13

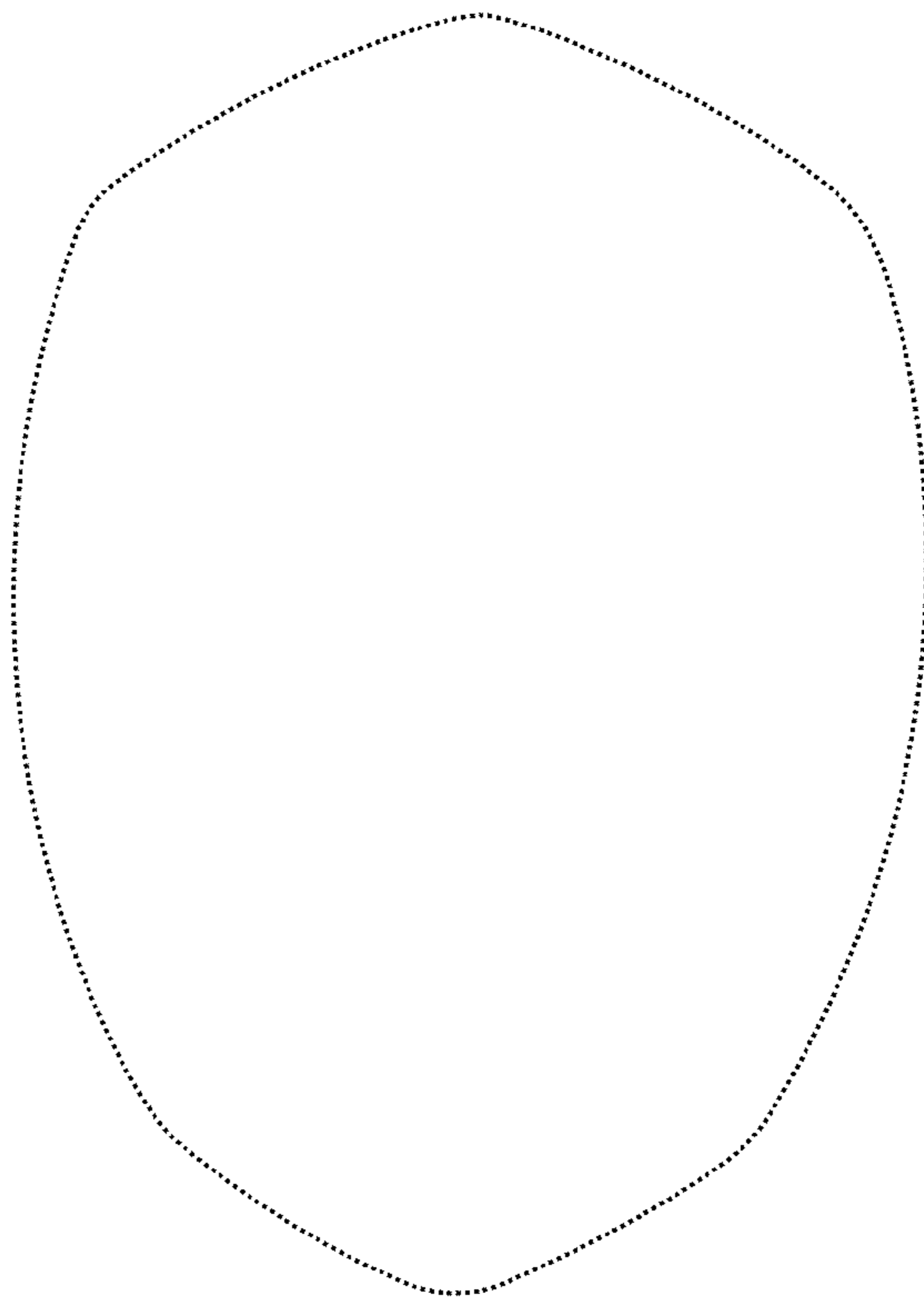

FIG. 14

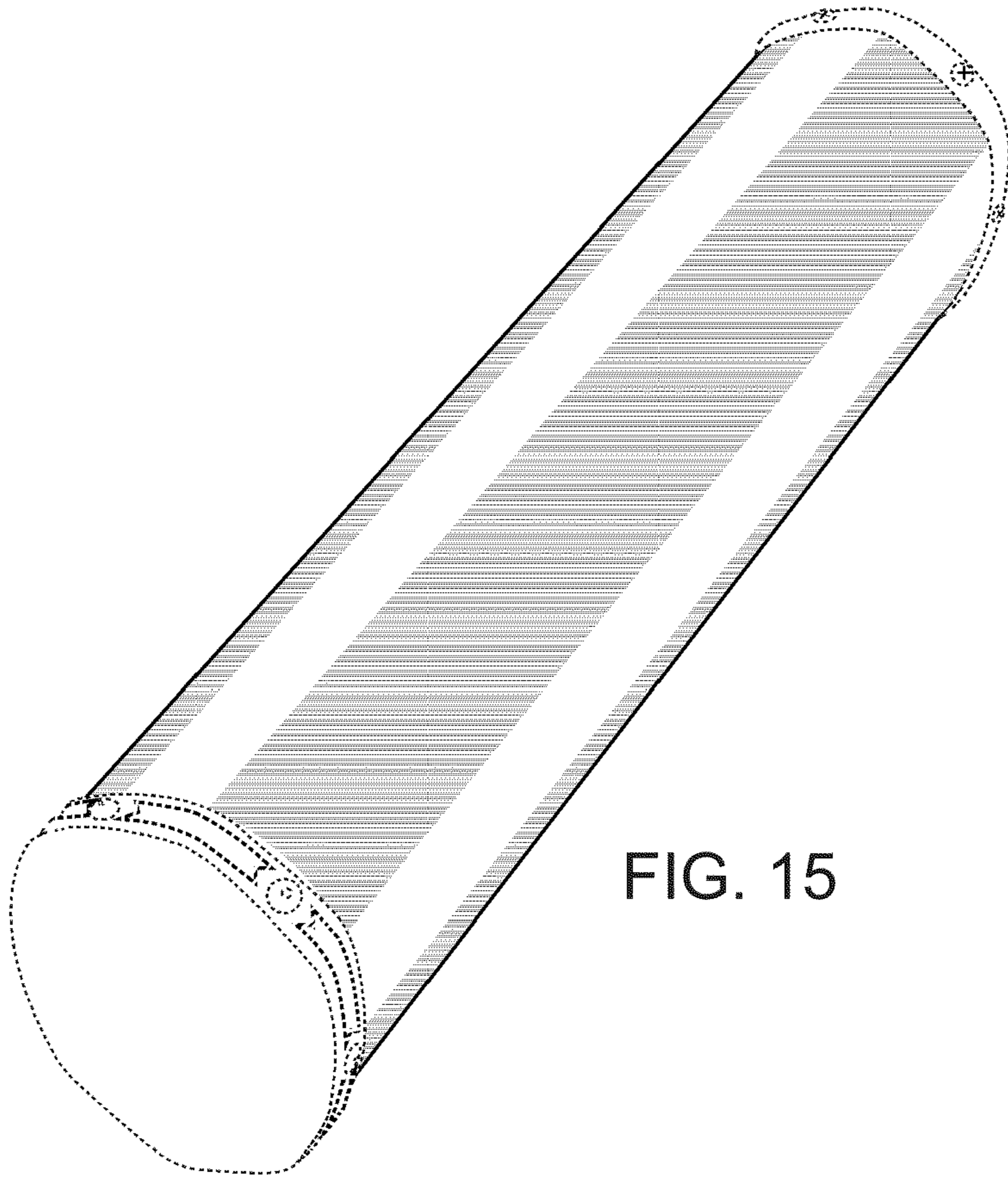

FIG. 15

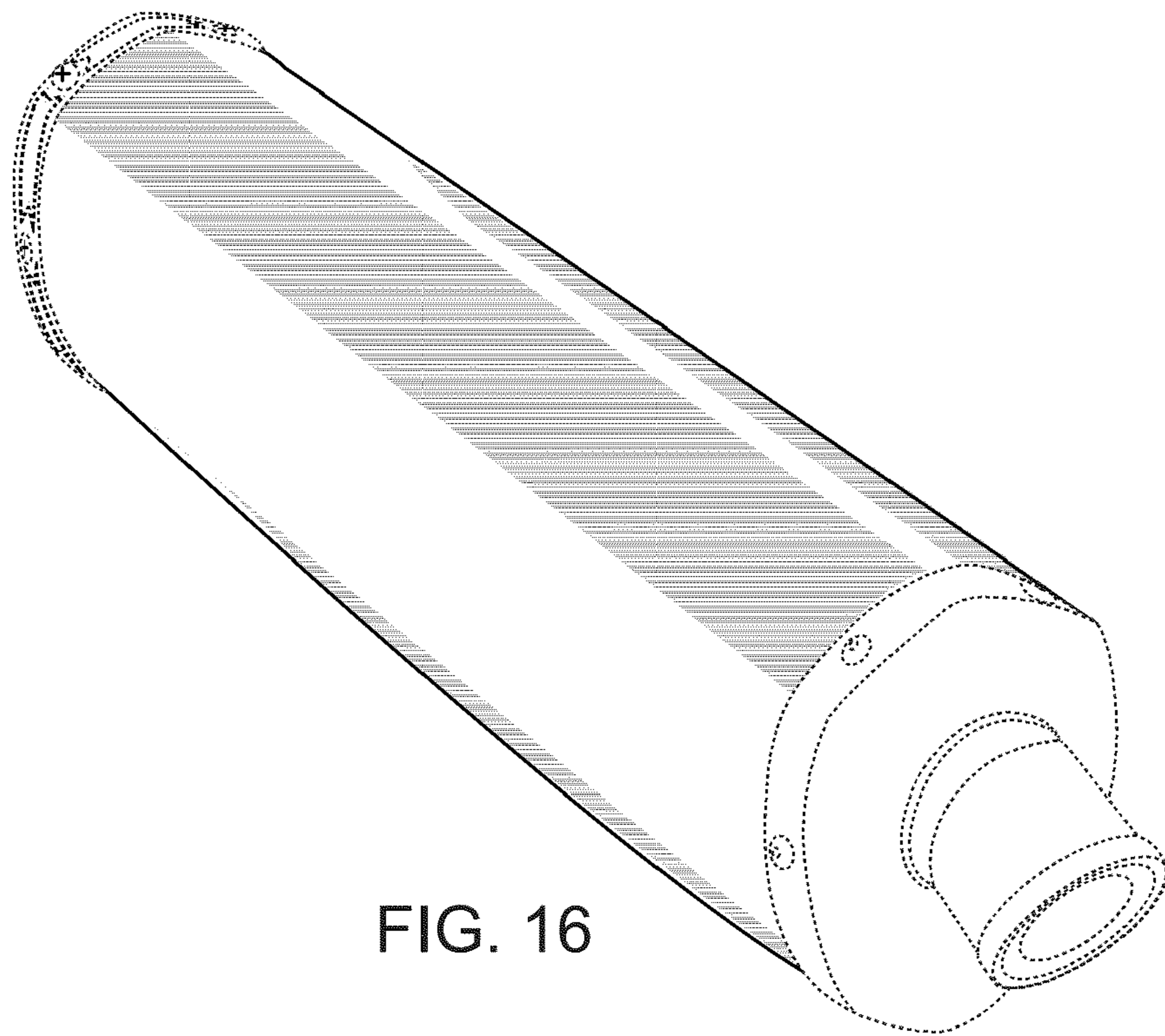

FIG. 16