



US00D592708S

(12) **United States Design Patent**
Hsu

(10) **Patent No.:** **US D592,708 S**

(45) **Date of Patent:** **** May 19, 2009**

(54) **ROUND CABINET**

(76) **Inventor:** **Tien Shu Hsu**, 5F-8, No. 210, Gungye
38 Rd., Shiturn Chiu, Taichung City
(TW)

(**) **Term:** **14 Years**

(21) **Appl. No.:** **29/299,795**

(22) **Filed:** **Jan. 4, 2008**

(51) **LOC (9) Cl.** **21-03**

(52) **U.S. Cl.** **D21/369**

(58) **Field of Classification Search** D6/446,
D6/337, 357, 469; D21/325, 327, 329, 324,
D21/333, 369; D14/124, 125; 463/1, 29-35,
463/46-47, 49-50

See application file for complete search history.

(56) **References Cited**

U.S. PATENT DOCUMENTS

D251,395 S *	3/1979	Kula	D21/327
D377,670 S *	1/1997	Means et al.	D21/327
D410,256 S *	5/1999	Uehara et al.	D21/327
D411,259 S *	6/1999	Ishii et al.	D21/329
D415,211 S *	10/1999	Yamaguchi	D21/327
D439,282 S *	3/2001	Yamaguchi	D21/329
D458,310 S *	6/2002	Lynch	D21/369
D521,570 S *	5/2006	Tsai	D21/397
D523,093 S *	6/2006	Kaminkow et al.	D21/369
D532,831 S *	11/2006	Baerlocher et al.	D21/385
D536,386 S *	2/2007	Kaminkow et al.	D21/385

D537,886 S *	3/2007	Kaminkow et al.	D21/385
D547,387 S *	7/2007	Maguire et al.	D21/369
D548,802 S *	8/2007	Damjan et al.	D21/375
D558,276 S *	12/2007	Damjan et al.	D21/375
D561,266 S *	2/2008	Baazov et al.	D21/369
D568,068 S *	5/2008	Riesenberg	D6/476
D572,918 S *	7/2008	Viets	D6/337

* cited by examiner

Primary Examiner—Elizabeth A Albert

Assistant Examiner—Kelley A Donnelly

(74) *Attorney, Agent, or Firm*—Ming Chow; Sinorica, LLC

(57) **CLAIM**

I claim the ornamental design for a round cabinet, as shown and described.

DESCRIPTION

FIG. 1 is a front perspective view of a round cabinet showing my new design.

FIG. 2 is a front elevational view thereof;

FIG. 3 is a rear elevational view thereof;

FIG. 4 is a left side elevational view thereof;

FIG. 5 is a right side elevational view thereof;

FIG. 6 is a top plan view thereof; and,

FIG. 7 is a bottom plan view thereof.

The broken lines are for environmental purposes only and form no part of the claimed design.

1 Claim, 5 Drawing Sheets

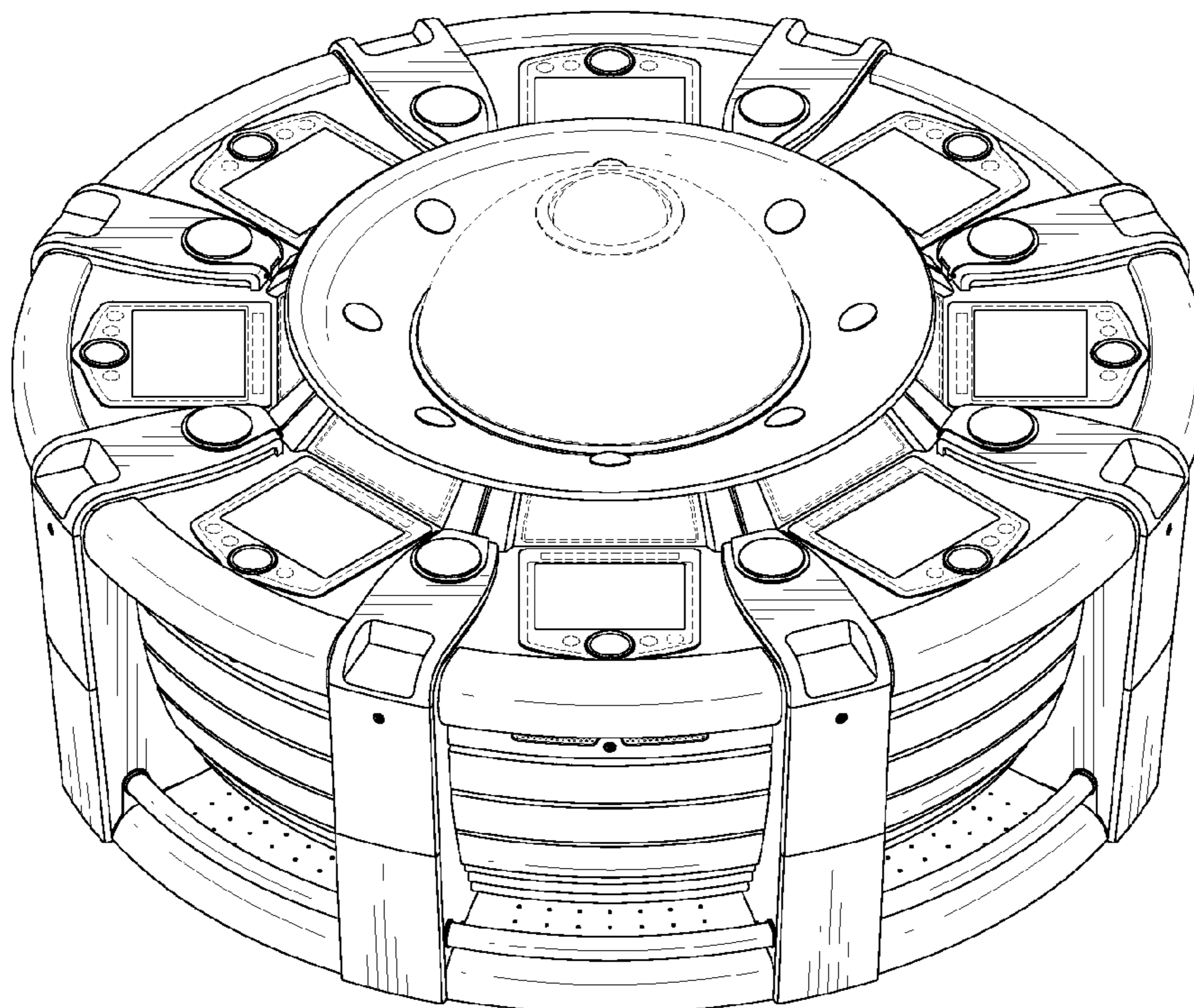

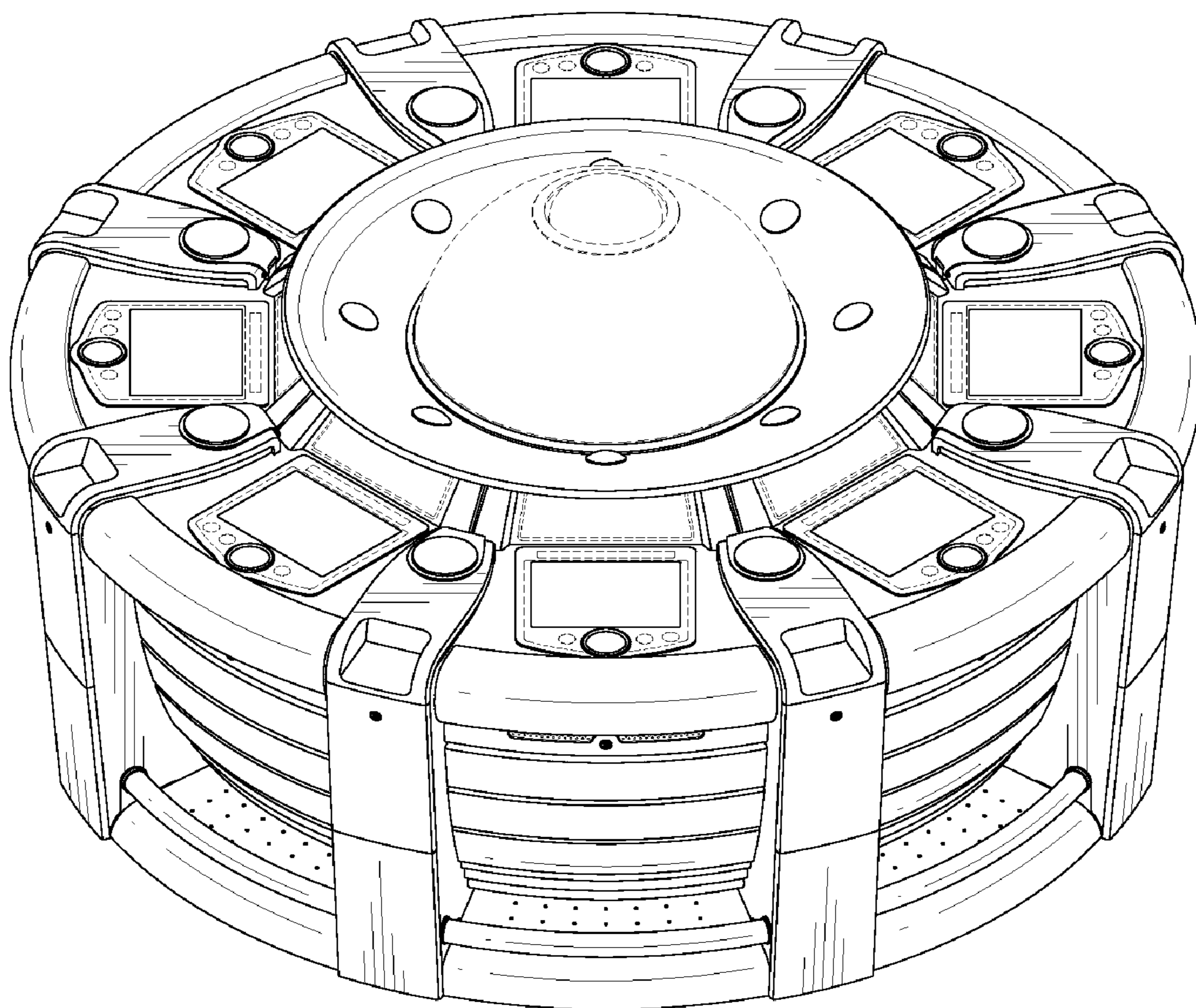

FIG. 1

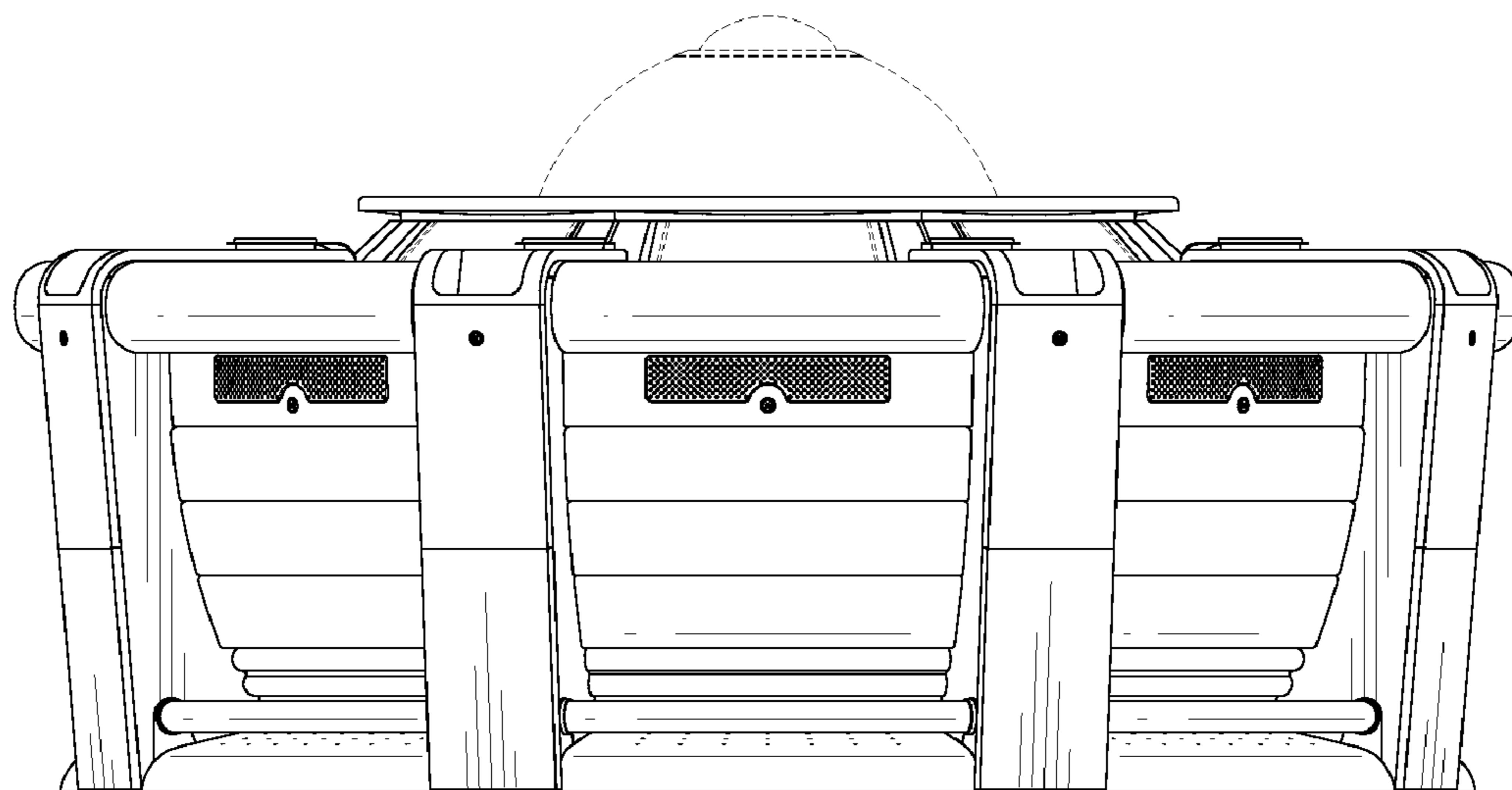

FIG. 2

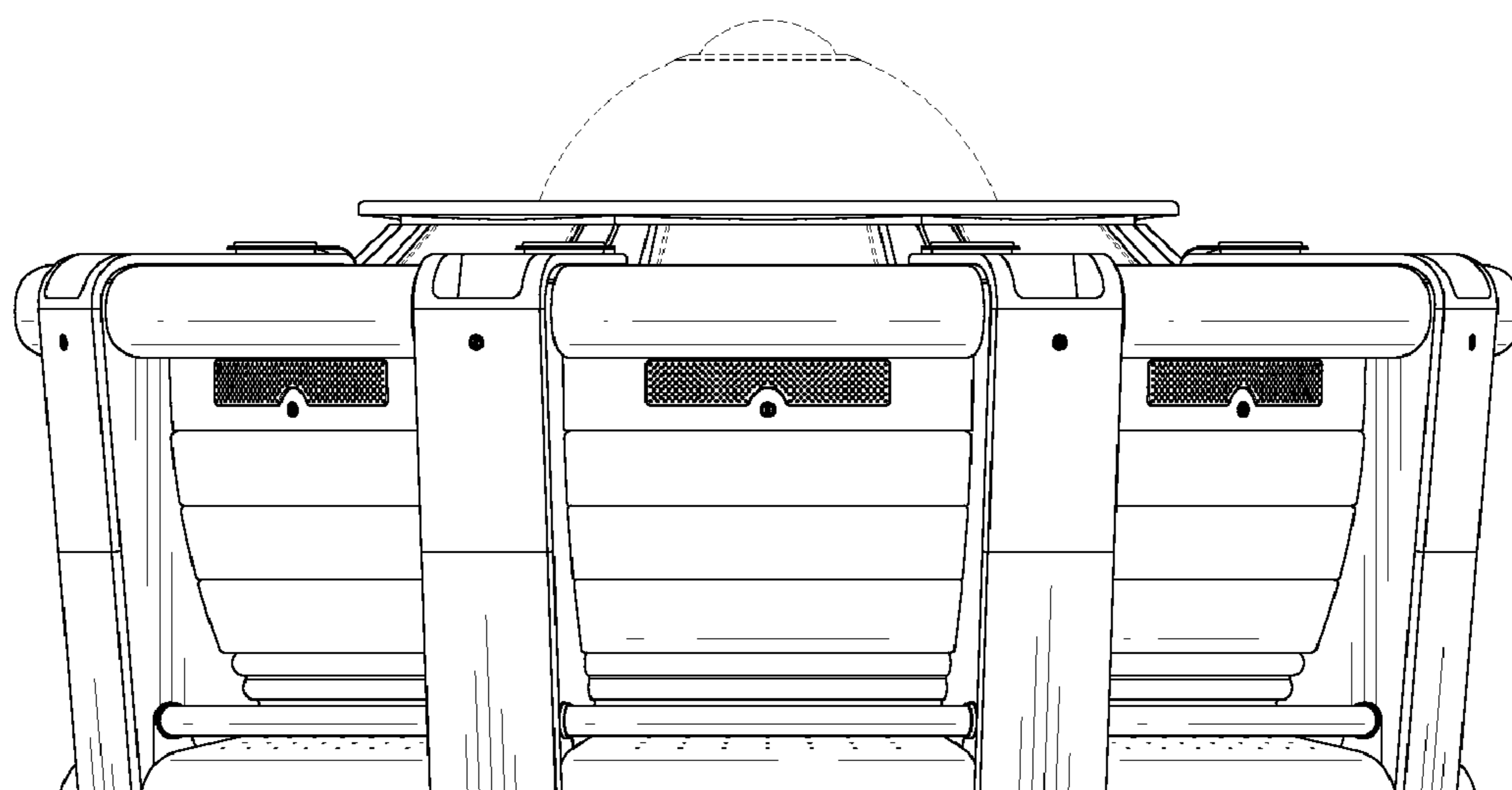

FIG. 3

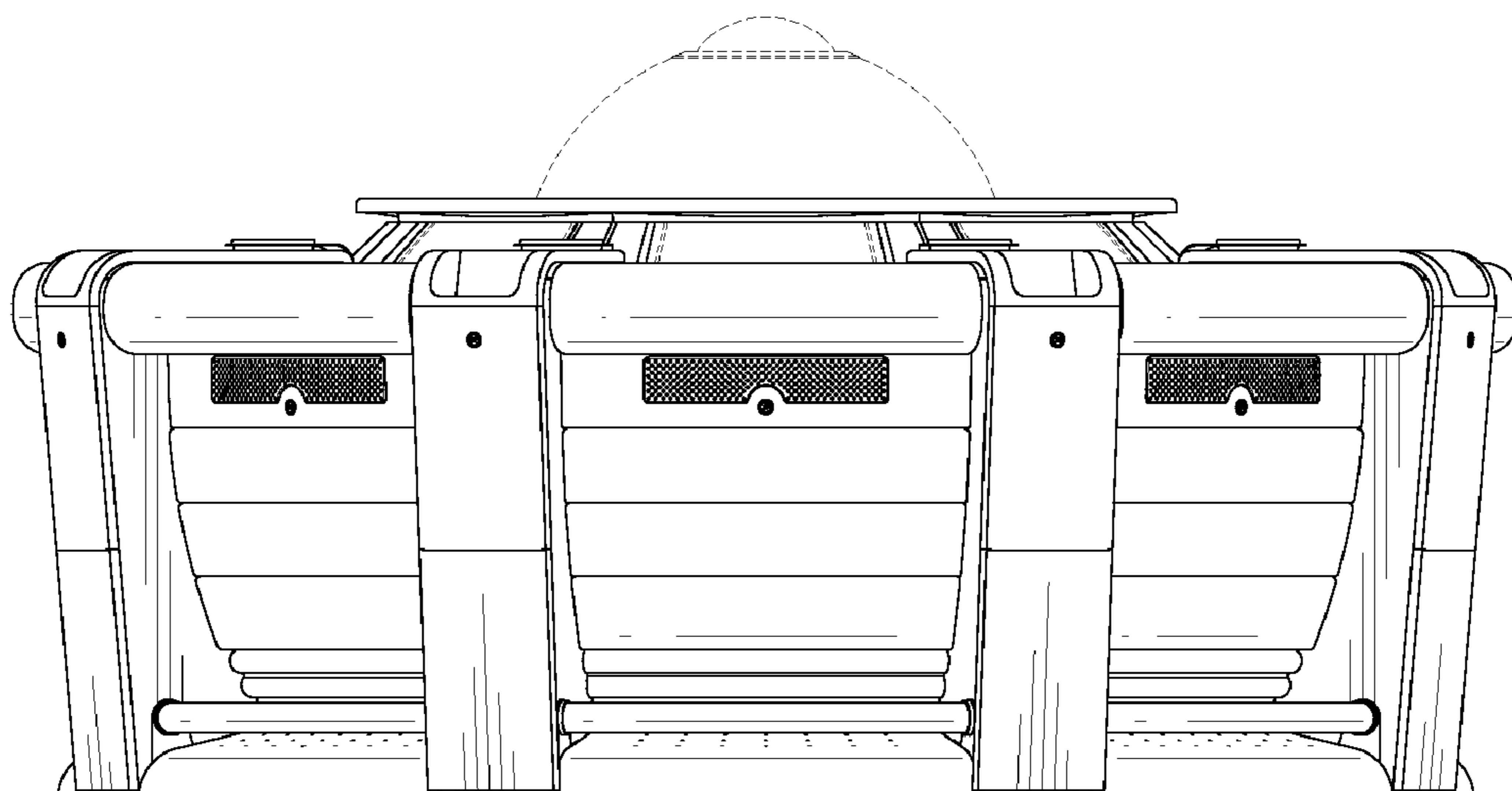

FIG. 4

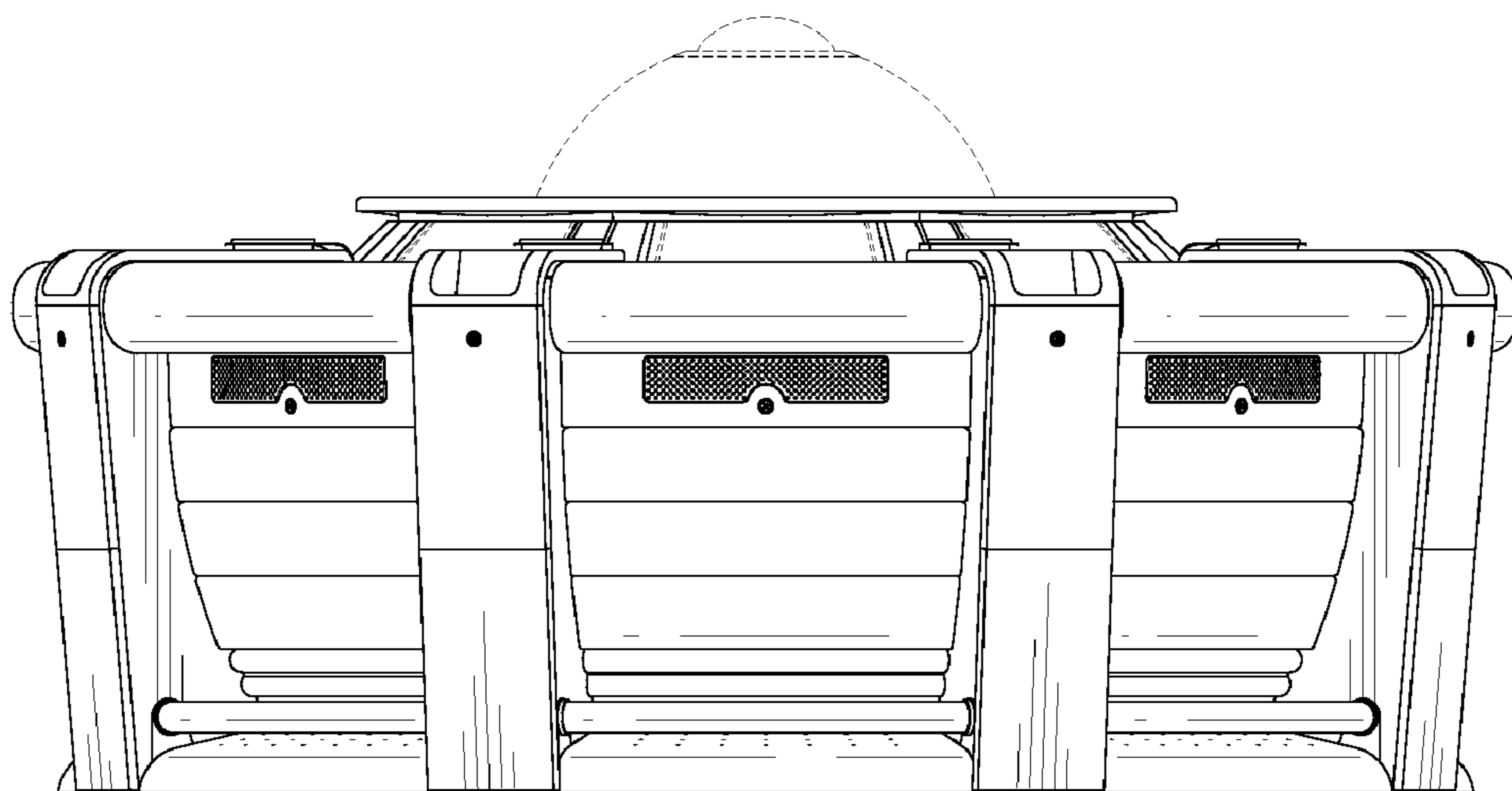

FIG. 5

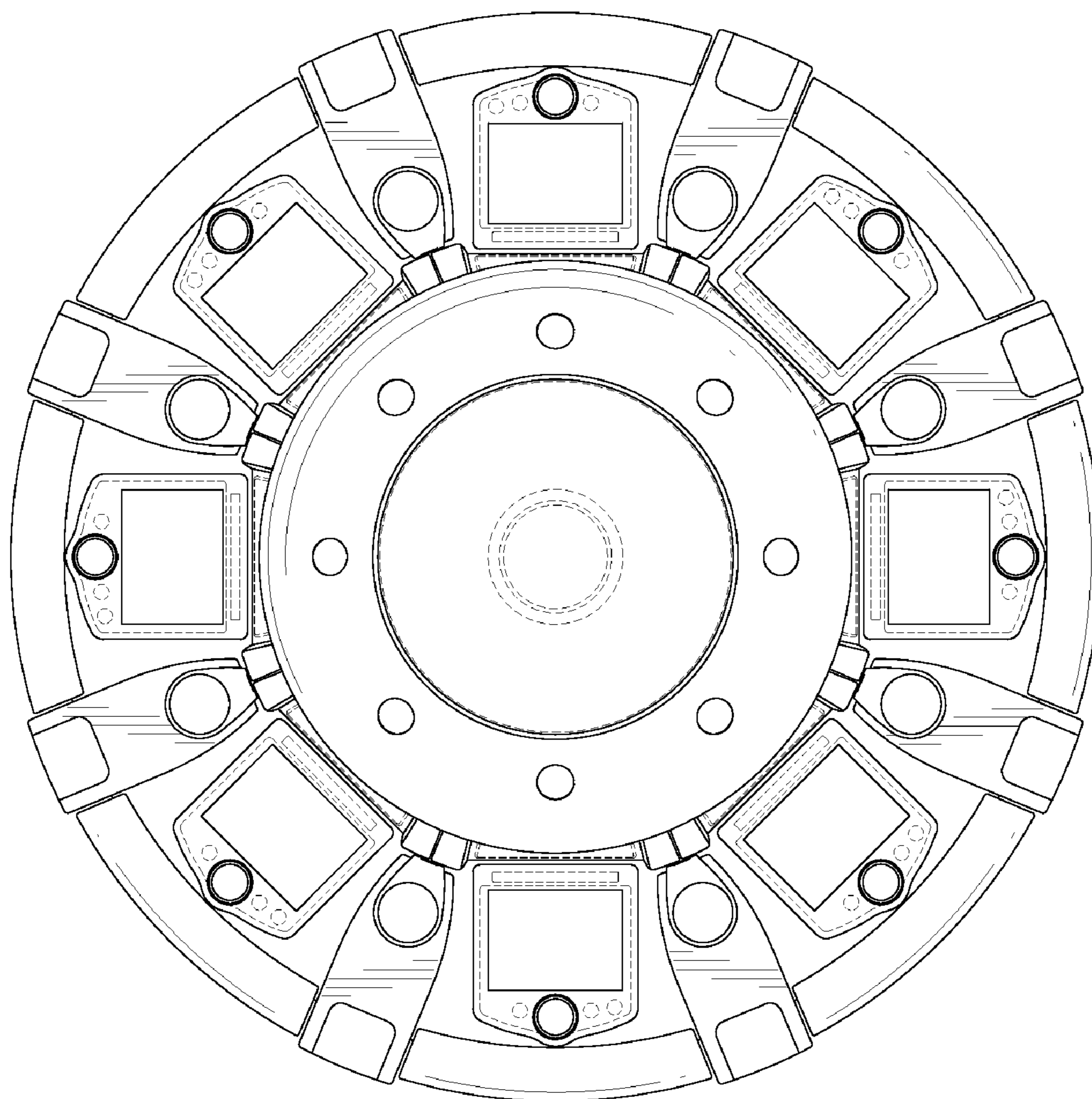

FIG. 6

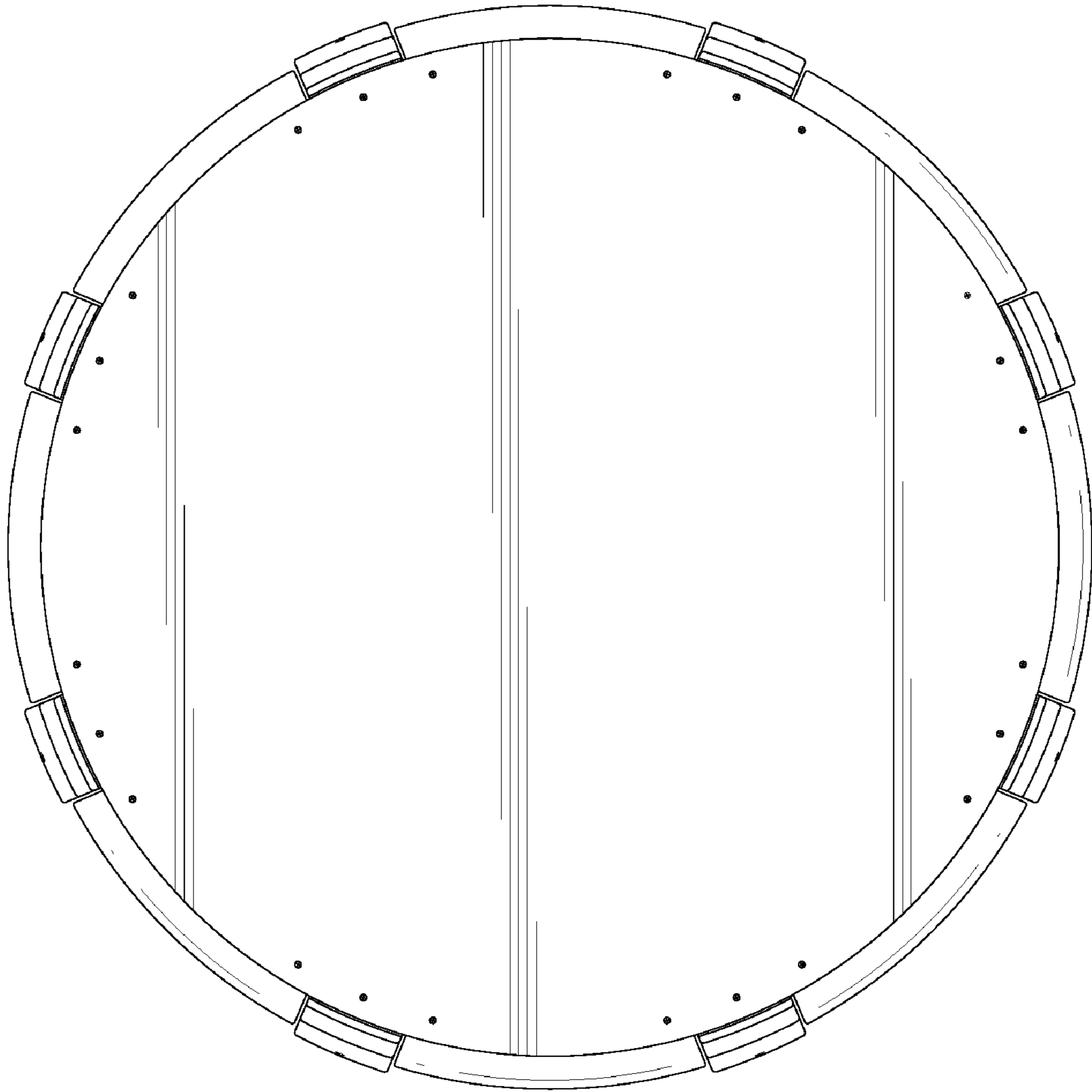

FIG. 7