

US00D592558S

(12) **United States Design Patent**
Staller

(10) **Patent No.:** **US D592,558 S**

(45) **Date of Patent:** **** May 19, 2009**

(54) **TWO-PASSENGER PEDALED VEHICLE**

D301,216 S * 5/1989 Lawson D12/112

(76) Inventor: **Eric Staller**, Herengracht 100, 1015 BS
Amsterdam (NL)

* cited by examiner

Primary Examiner—Ian Simmons

Assistant Examiner—Linda Brooks

(74) *Attorney, Agent, or Firm*—Bernhard P. Molldrem, Jr.

(**) Term: **14 Years**

(21) Appl. No.: **29/272,255**

(57) **CLAIM**

(22) Filed: **Feb. 5, 2007**

The ornamental design for a two-passenger pedaled vehicle,
as shown and described.

(51) **LOC (9) Cl.** **12-11**

(52) **U.S. Cl.** **D12/112**

(58) **Field of Classification Search** D12/107,
D12/109, 111, 112; 280/209, 222, 230–234,
280/259, 263, 267, 203, 270, 274, 275, 278,
280/282, 273, 240, 211, 281.1, 288.1–288.3

See application file for complete search history.

DESCRIPTION

FIG. 1 is a left-front perspective view of a two-passenger
pedaled vehicle showing my new design, with the pedals,
cranks, and springs being drawn in broken lines and not being
part of my design.

FIG. 2 is a left side elevation thereof.

FIG. 3 is a front elevation thereof.

FIG. 4 is a right side elevation thereof.

FIG. 5 is a rear elevation thereof; and,

FIG. 6 is a top plan thereof.

The under side of the vehicle does not form any part of the
claimed design.

(56) **References Cited**

U.S. PATENT DOCUMENTS

- 3,175,843 A * 3/1965 Burke 280/209
- 3,664,684 A * 5/1972 Long 280/231
- 3,870,338 A * 3/1975 Holub 280/209
- D266,556 S * 10/1982 Arthur D12/112
- D289,271 S * 4/1987 Hendrickson et al. D12/112

1 Claim, 4 Drawing Sheets

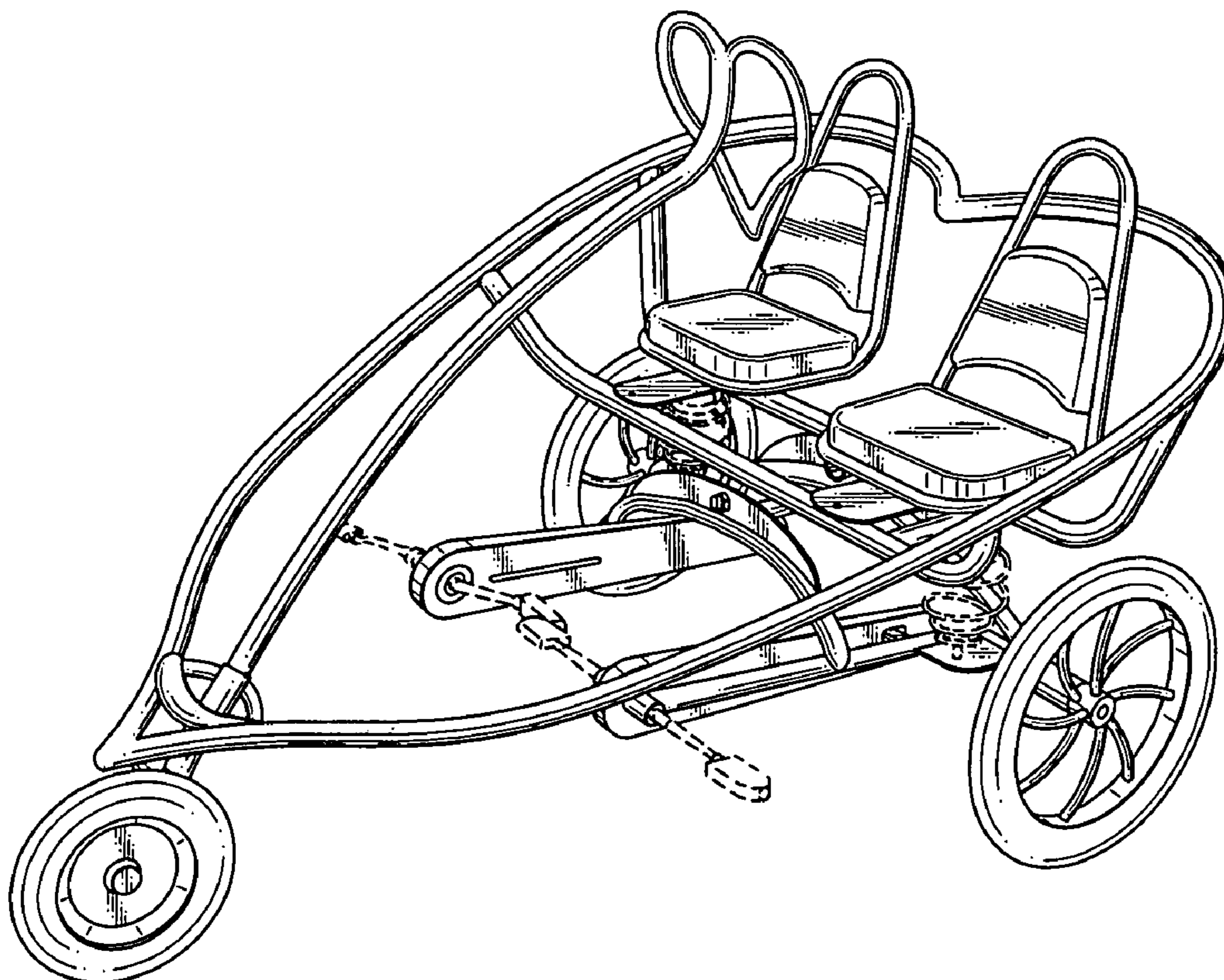

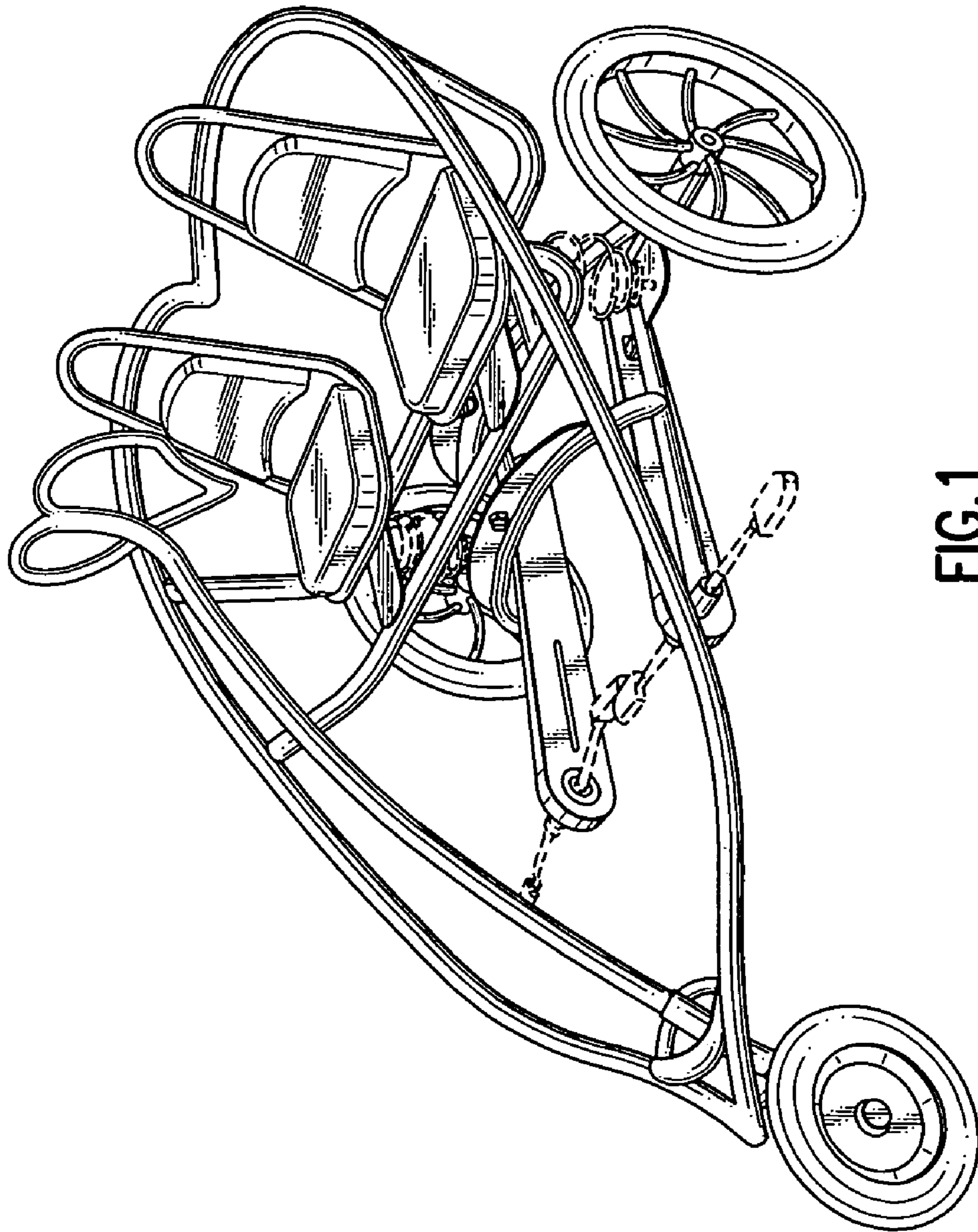

FIG. 1

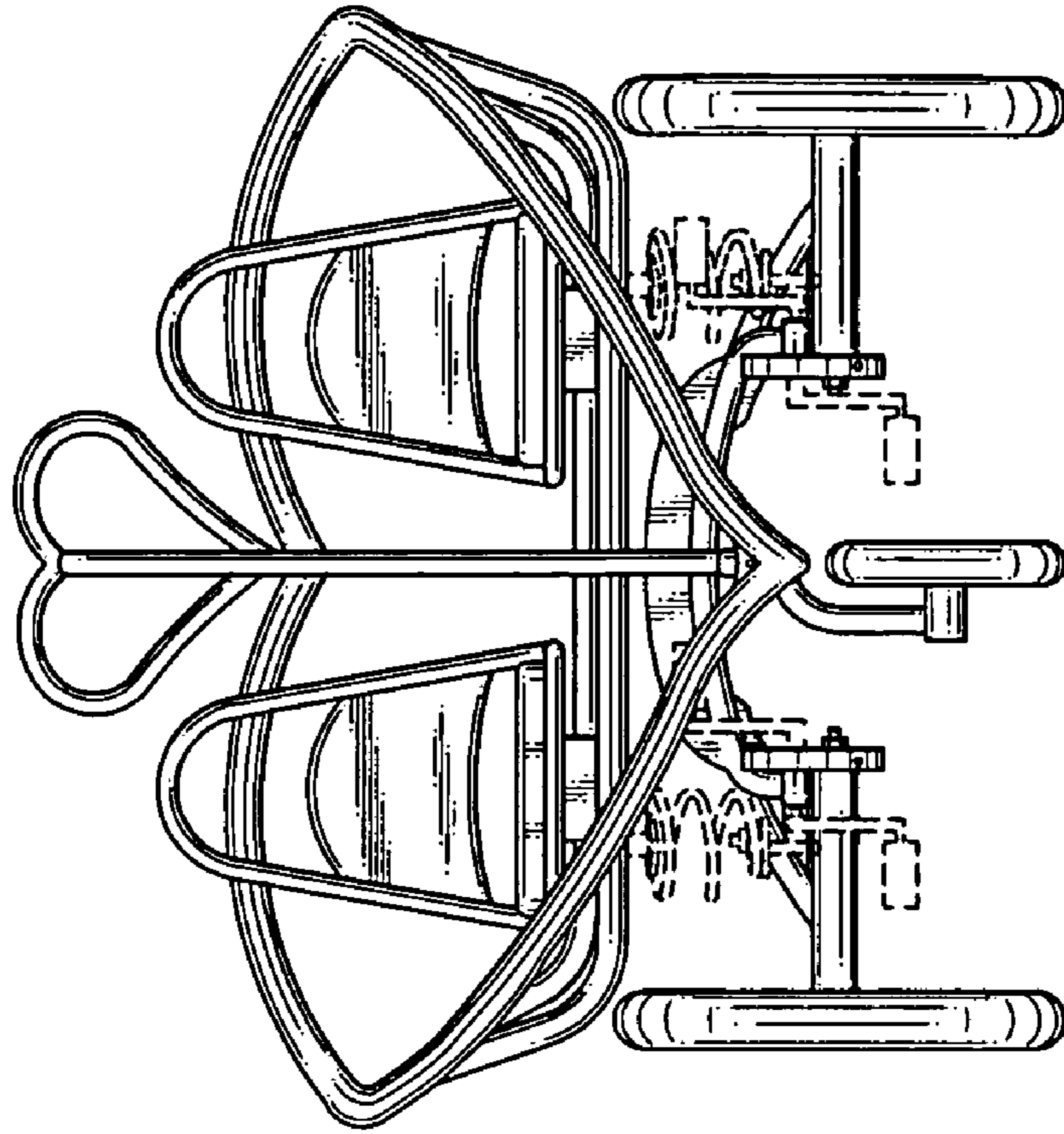

FIG. 3

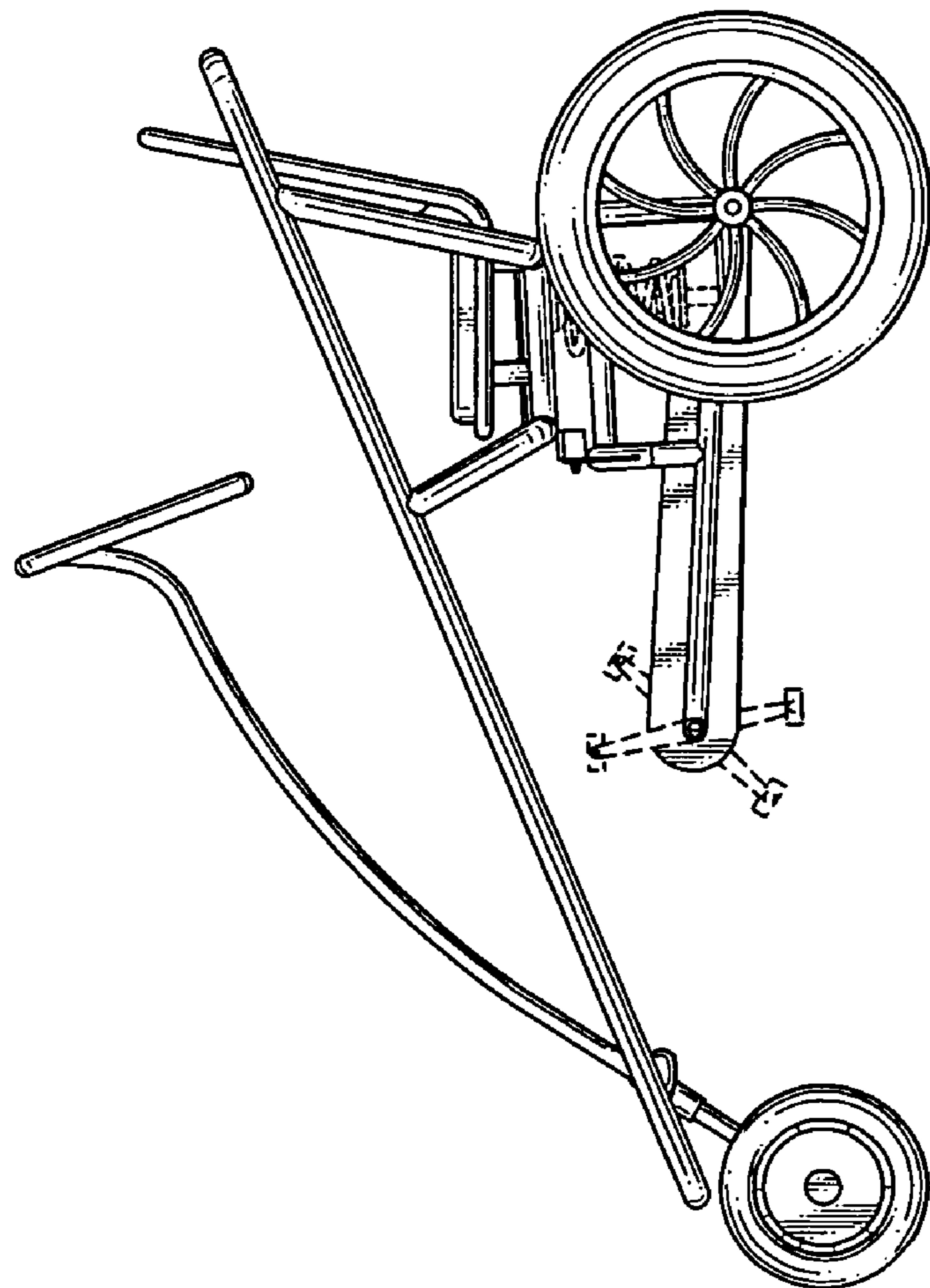

FIG. 2

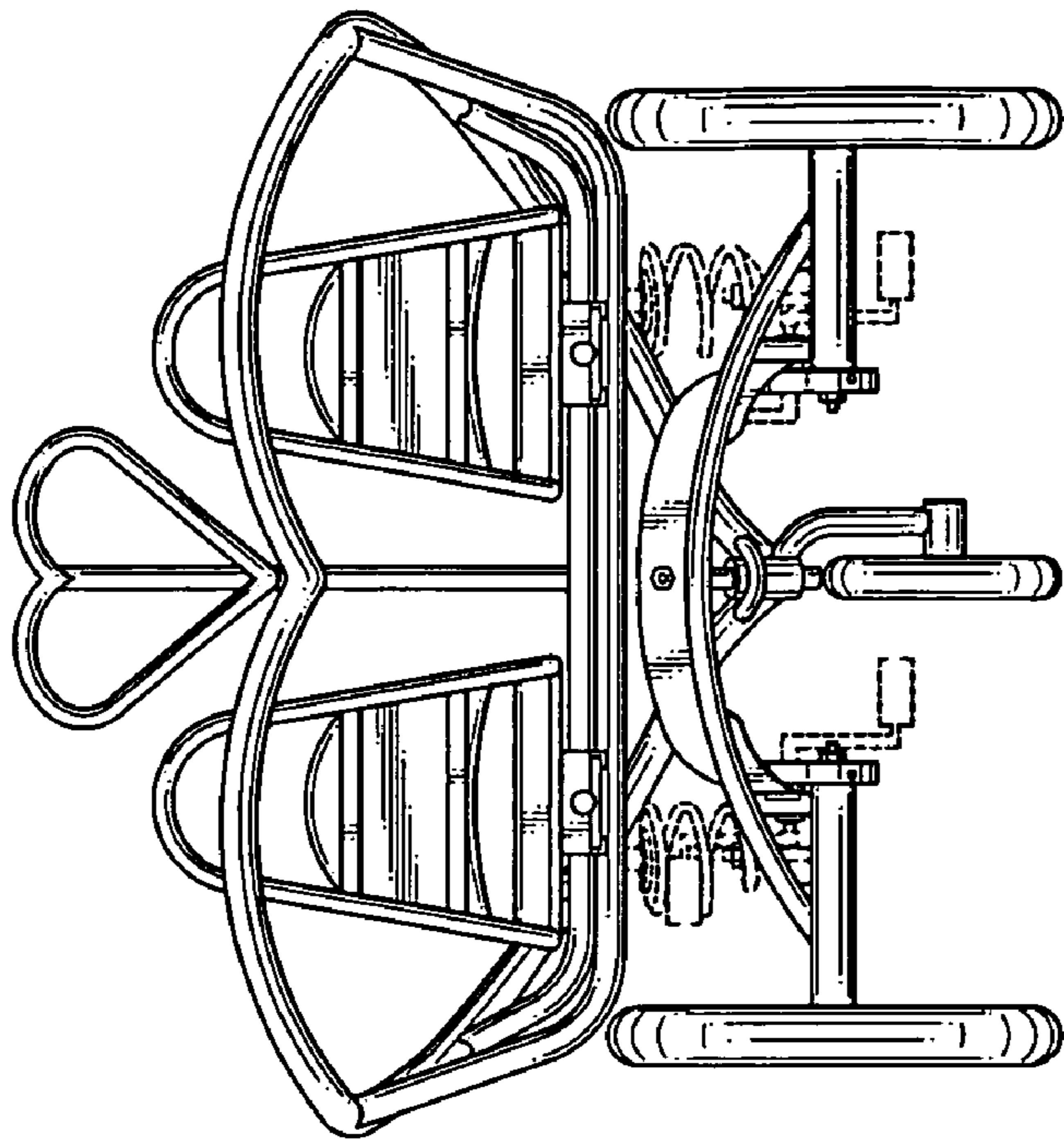

FIG. 5

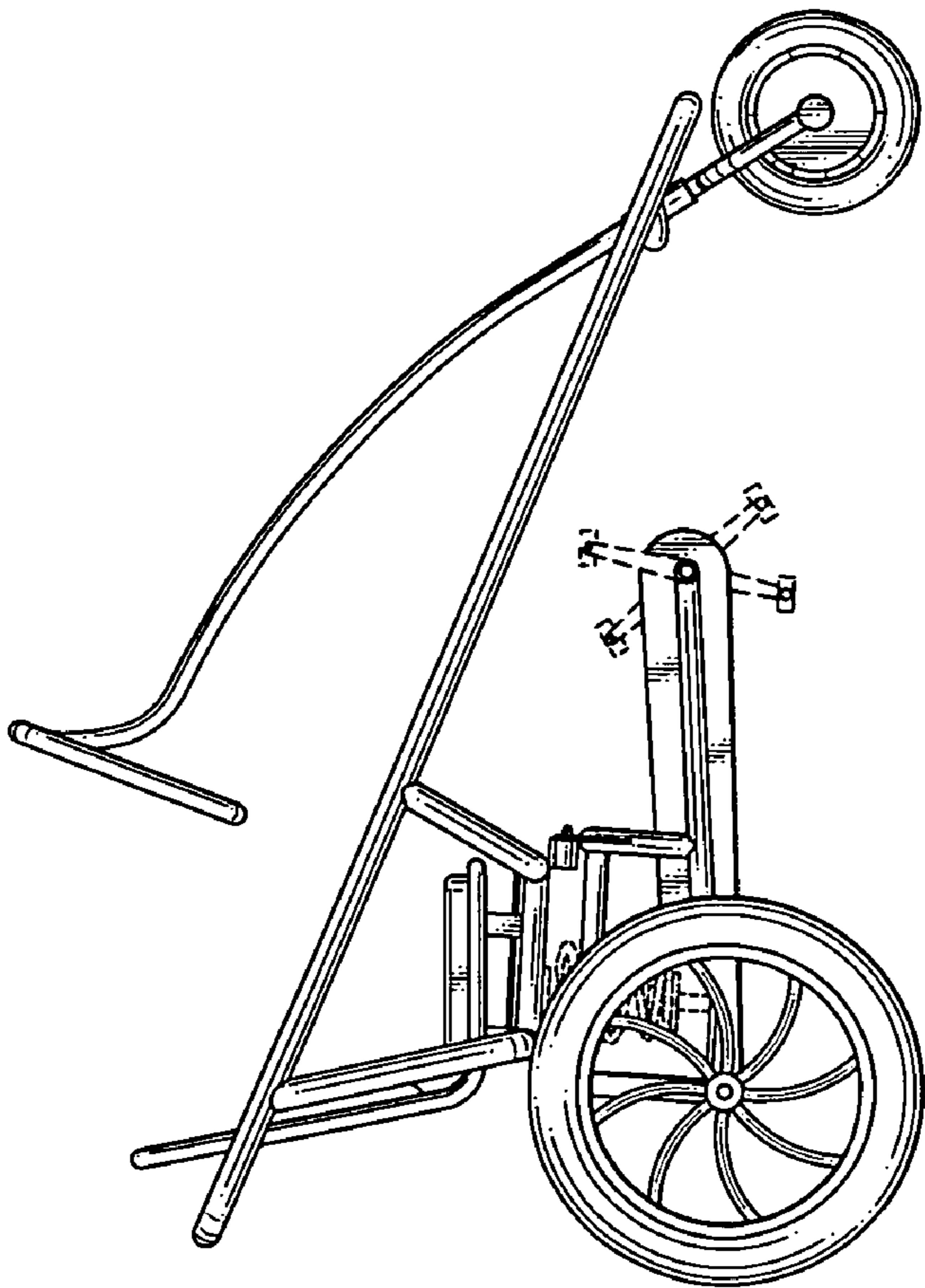

FIG. 4

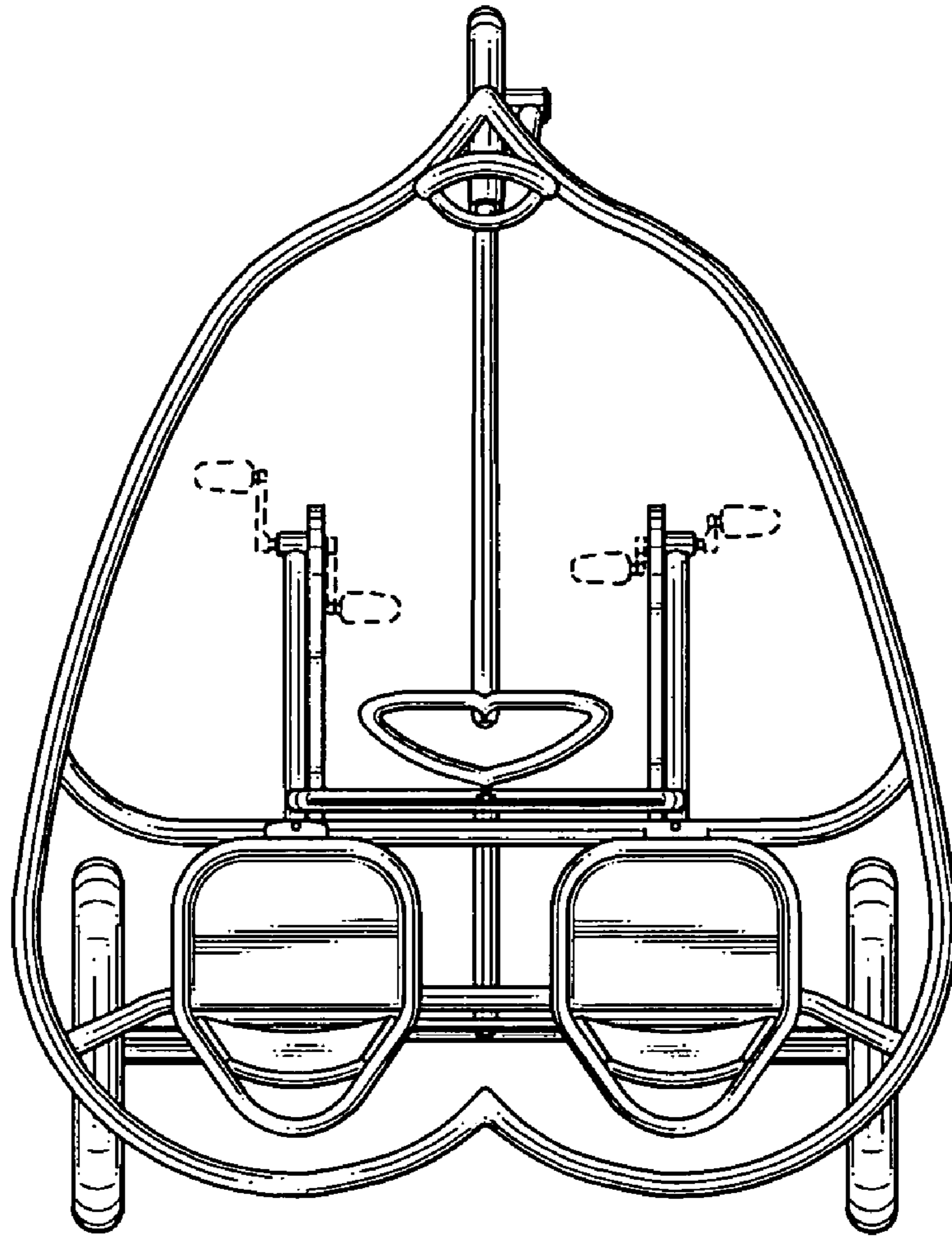

FIG.6