



US00D592331S

(12) **United States Design Patent**
Hsu

(10) **Patent No.:** **US D592,331 S**
(45) **Date of Patent:** **** May 12, 2009**

(54) **VEHICLE FRONT LIGHT UNIT**

D570,014 S * 5/2008 Hsu D26/28
D570,016 S * 5/2008 Hsu D26/28

(76) Inventor: **Hong Ming Hsu**, No. 152, Sec 2,
Funong St. East District, Tainan City
(TW) 701

* cited by examiner

Primary Examiner—Marcus A. Jackson

(74) *Attorney, Agent, or Firm*—Alexander Chen

(**) Term: **14 Years**

(57) **CLAIM**

(21) Appl. No.: **29/329,523**

The ornamental design for an vehicle front light unit, as shown and described.

(22) Filed: **Dec. 16, 2008**

(51) **LOC (9) Cl.** **26-06**

DESCRIPTION

(52) **U.S. Cl.** **D26/28**

(58) **Field of Classification Search** D26/28-36;
362/459-468, 475-478, 485-487
See application file for complete search history.

FIG. 1 is perspective view from the front left of an exterior surface configuration of a vehicle front light unit. The drawings and descriptions represent the right side embodiment. The design also contemplates a mirror symmetrical embodiment on the left side of the vehicle. The dash line included denotes environment and is not part of the claimed design

(56) **References Cited**

U.S. PATENT DOCUMENTS

| | | | | |
|--------------|--------|-----------|-------|--------|
| D550,380 S * | 9/2007 | Lin | | D26/28 |
| D560,291 S * | 1/2008 | Koyama | | D26/28 |
| D560,832 S * | 1/2008 | Hsu | | D26/28 |
| D561,358 S * | 2/2008 | Tachibana | | D26/28 |
| D561,359 S * | 2/2008 | Hsu | | D26/28 |
| D563,576 S * | 3/2008 | Hanaoka | | D26/28 |
| D569,533 S * | 5/2008 | Hsu | | D26/28 |
| D570,007 S * | 5/2008 | Hsu | | D26/28 |

FIG. 2 is a front elevation view thereof;

FIG. 3 is a left elevation view thereof, and

FIG. 4 is a top view thereof.

FIG. 5 is an exploded perspective view from the front right thereof; and,

FIG. 6 is an exploded front elevation view thereof.

1 Claim, 6 Drawing Sheets

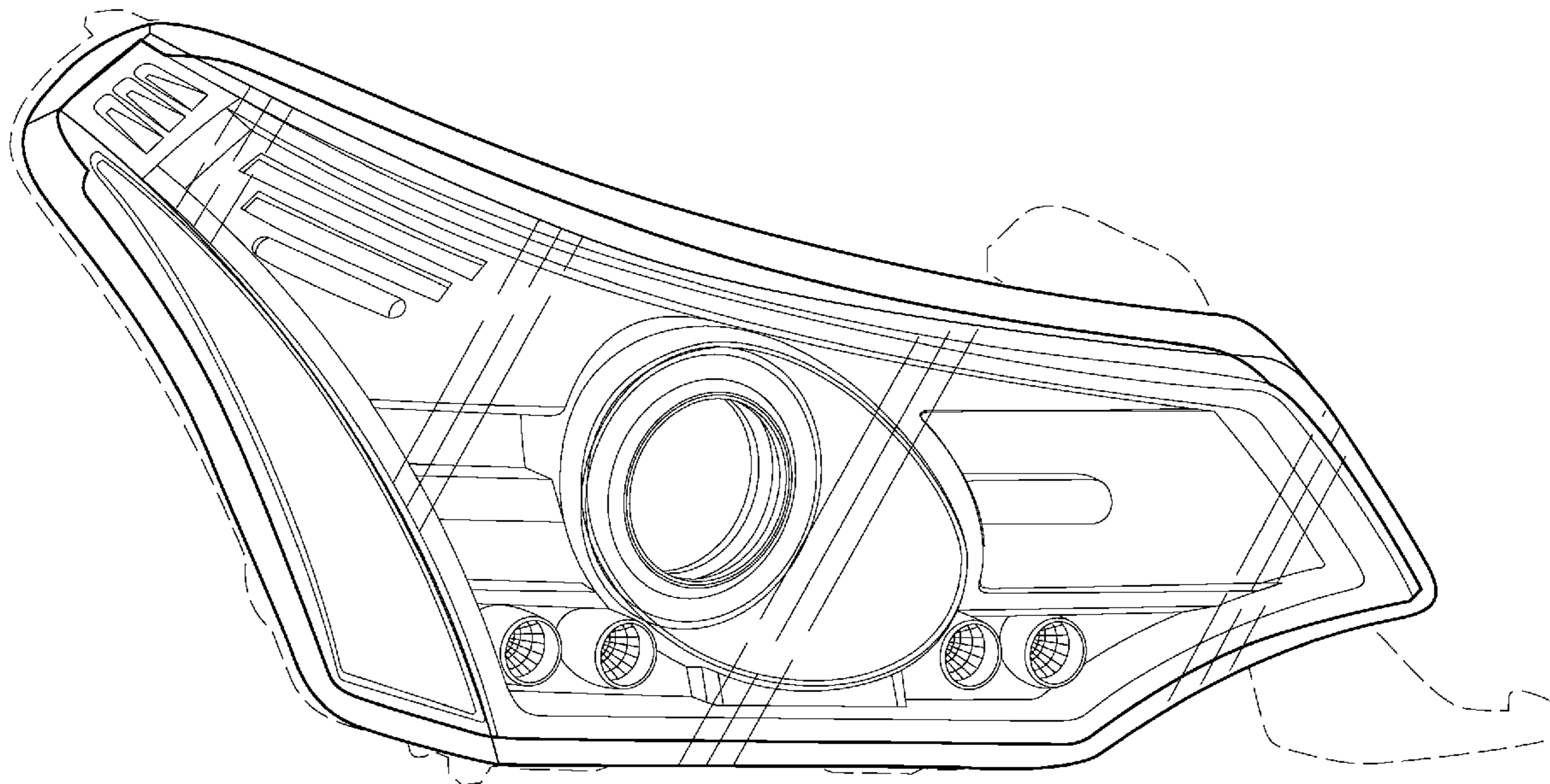

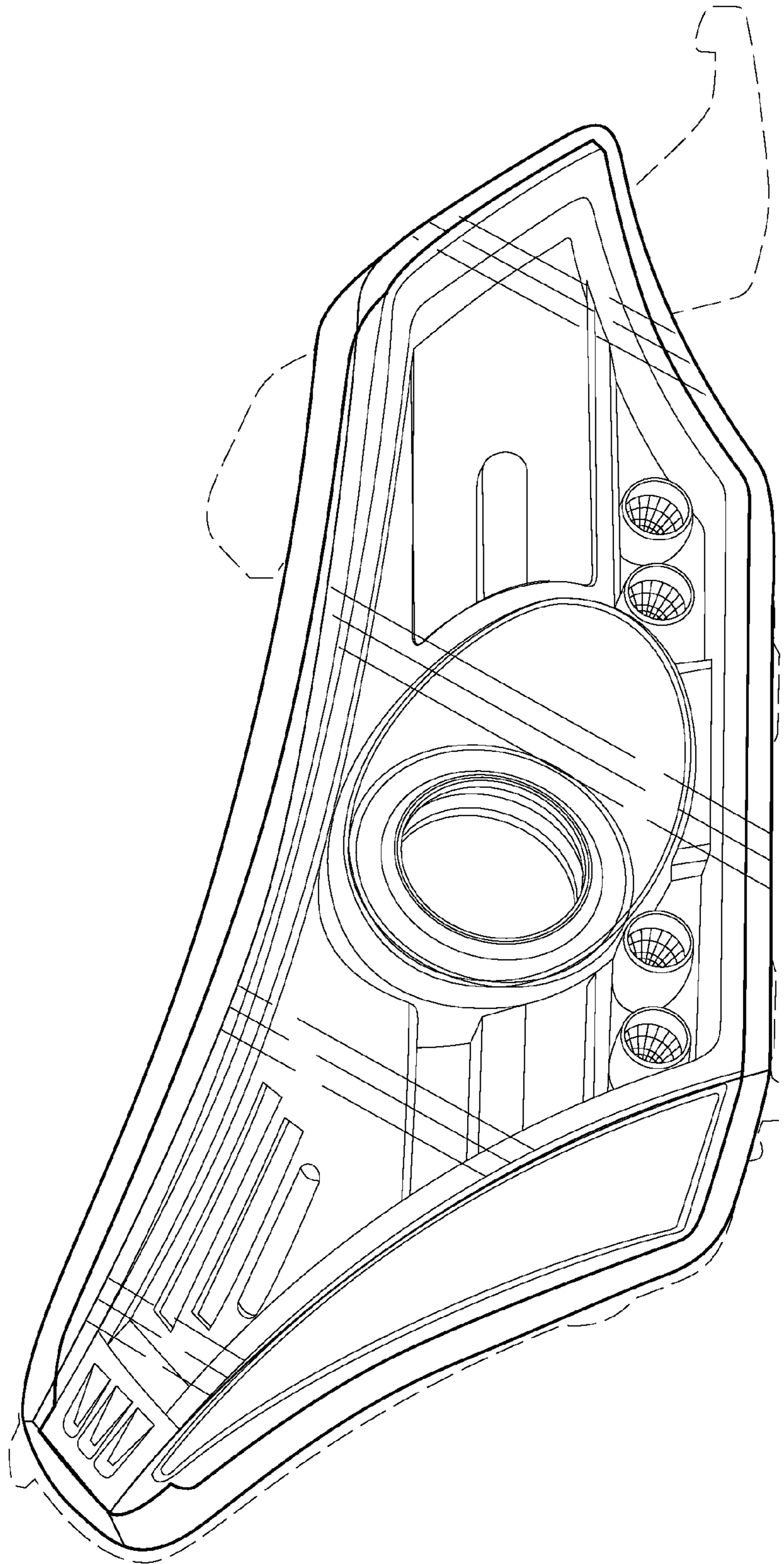

Fig. 1

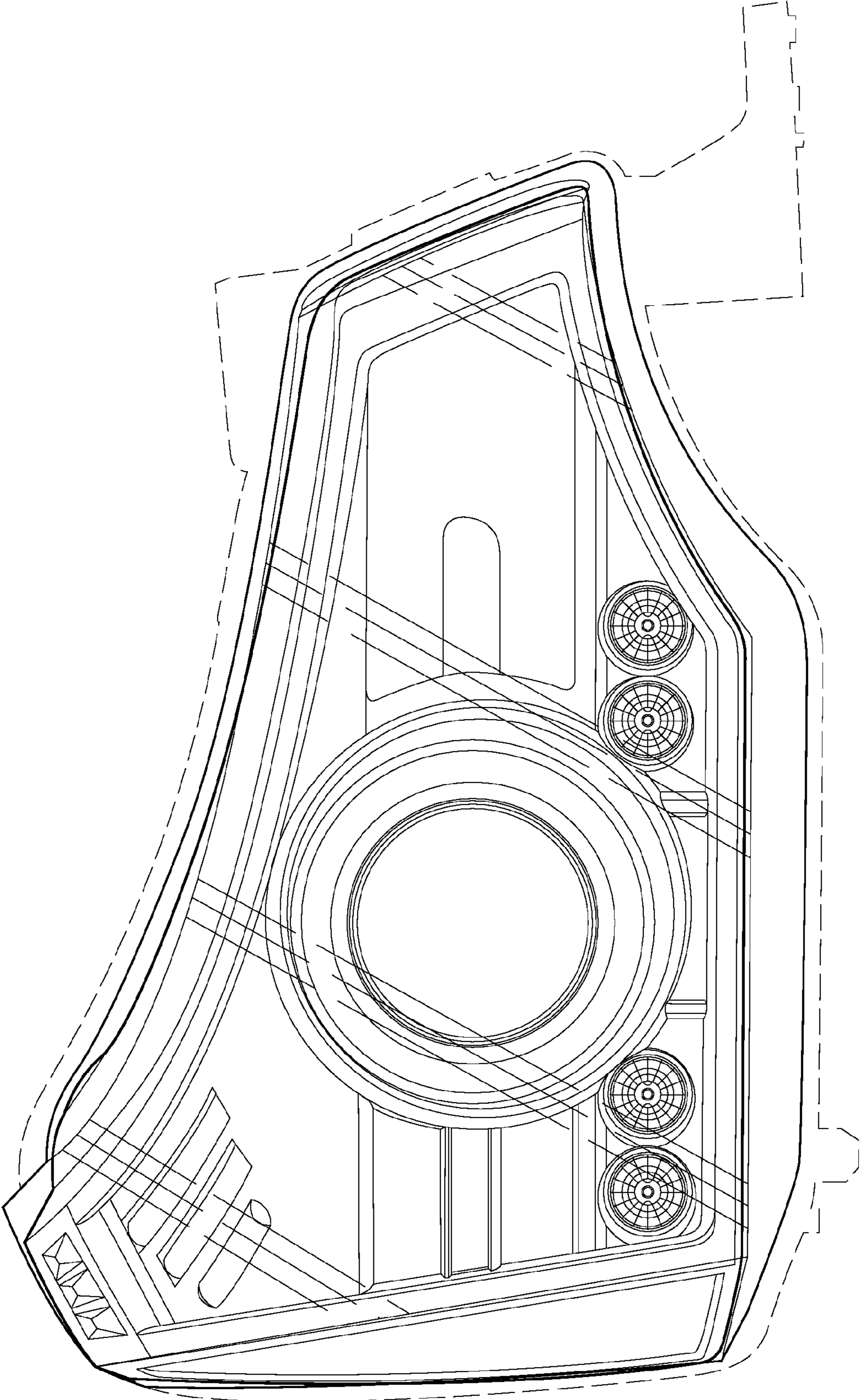

Fig. 2

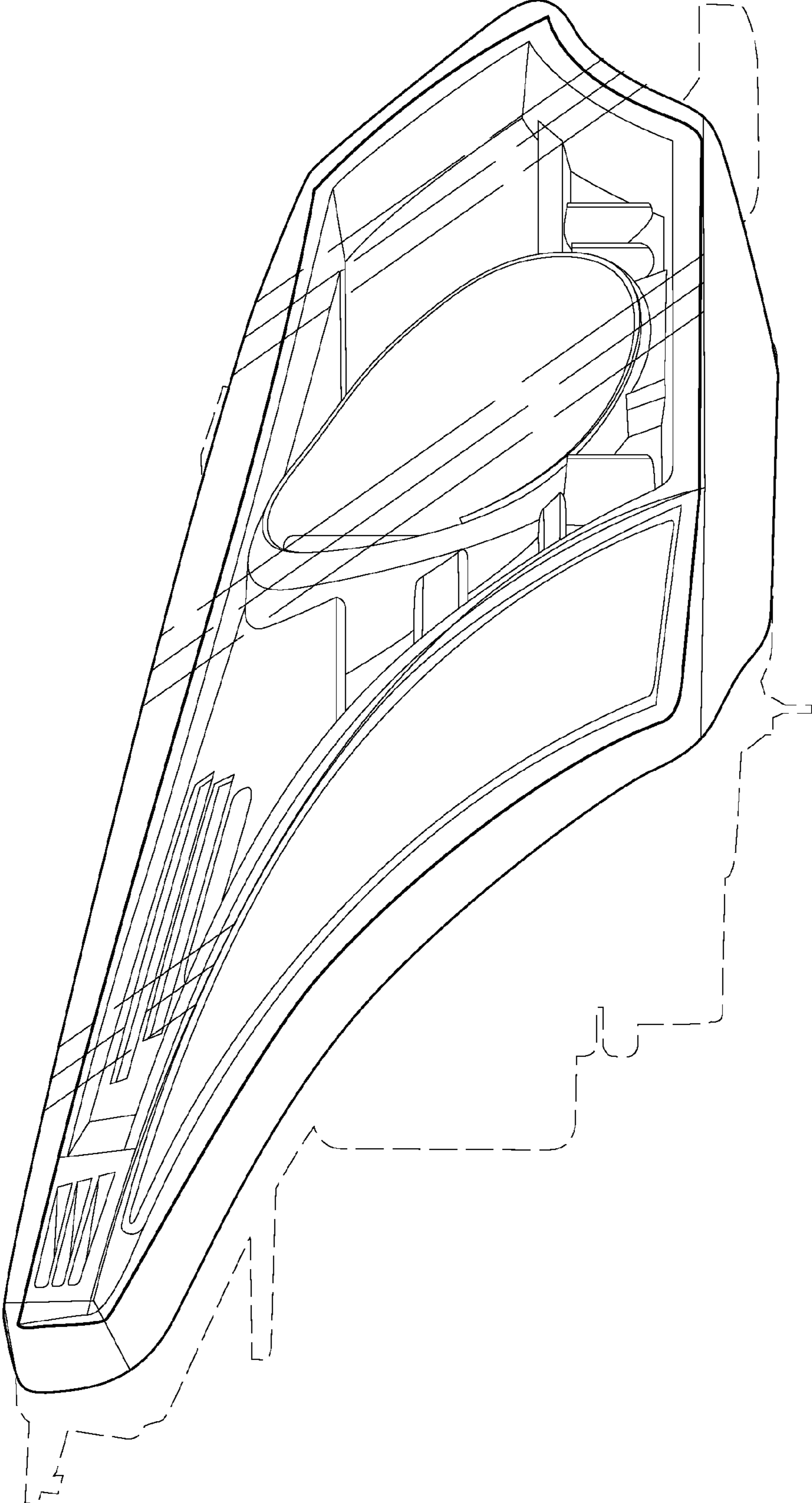

Fig. 3

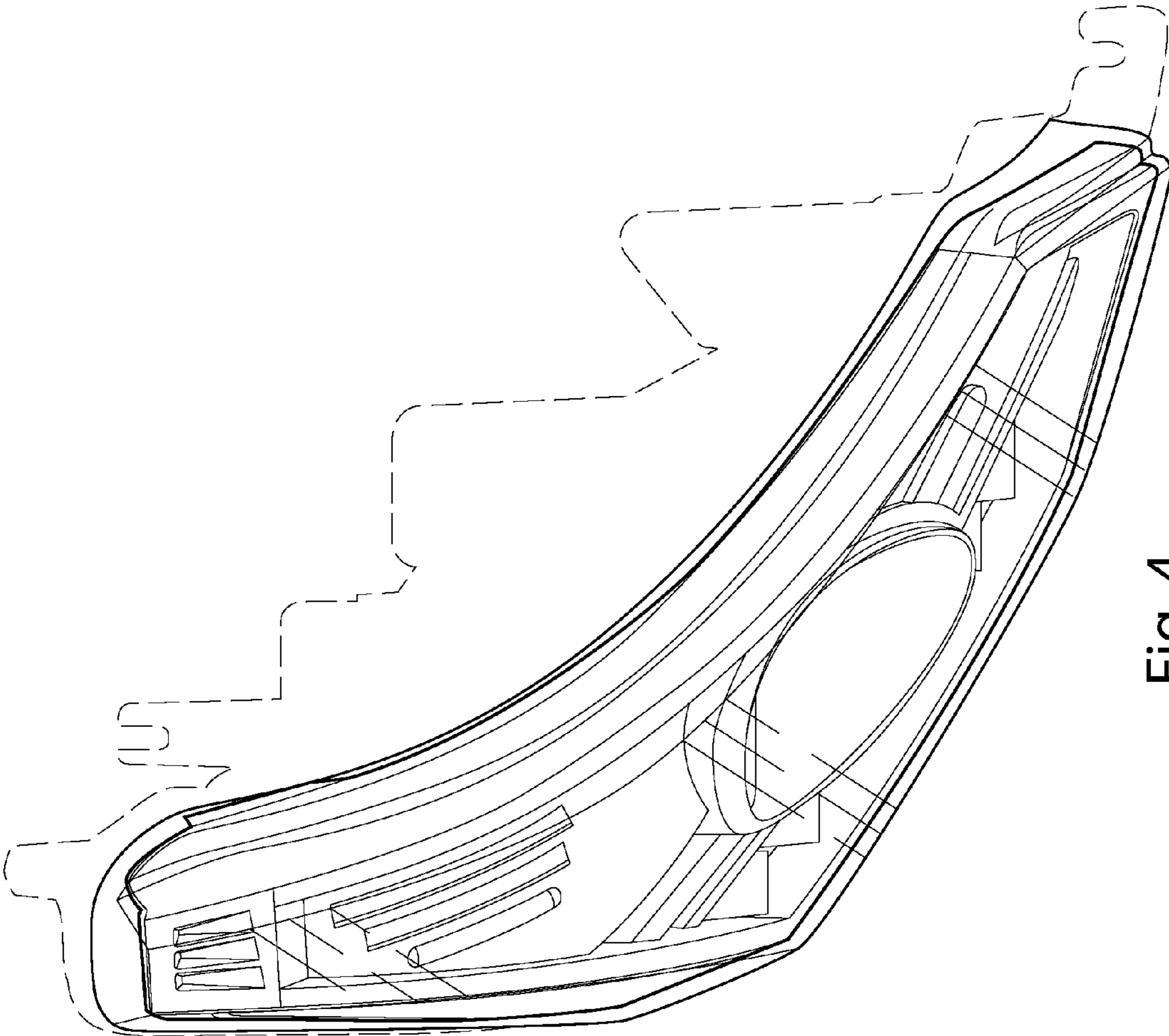

Fig. 4

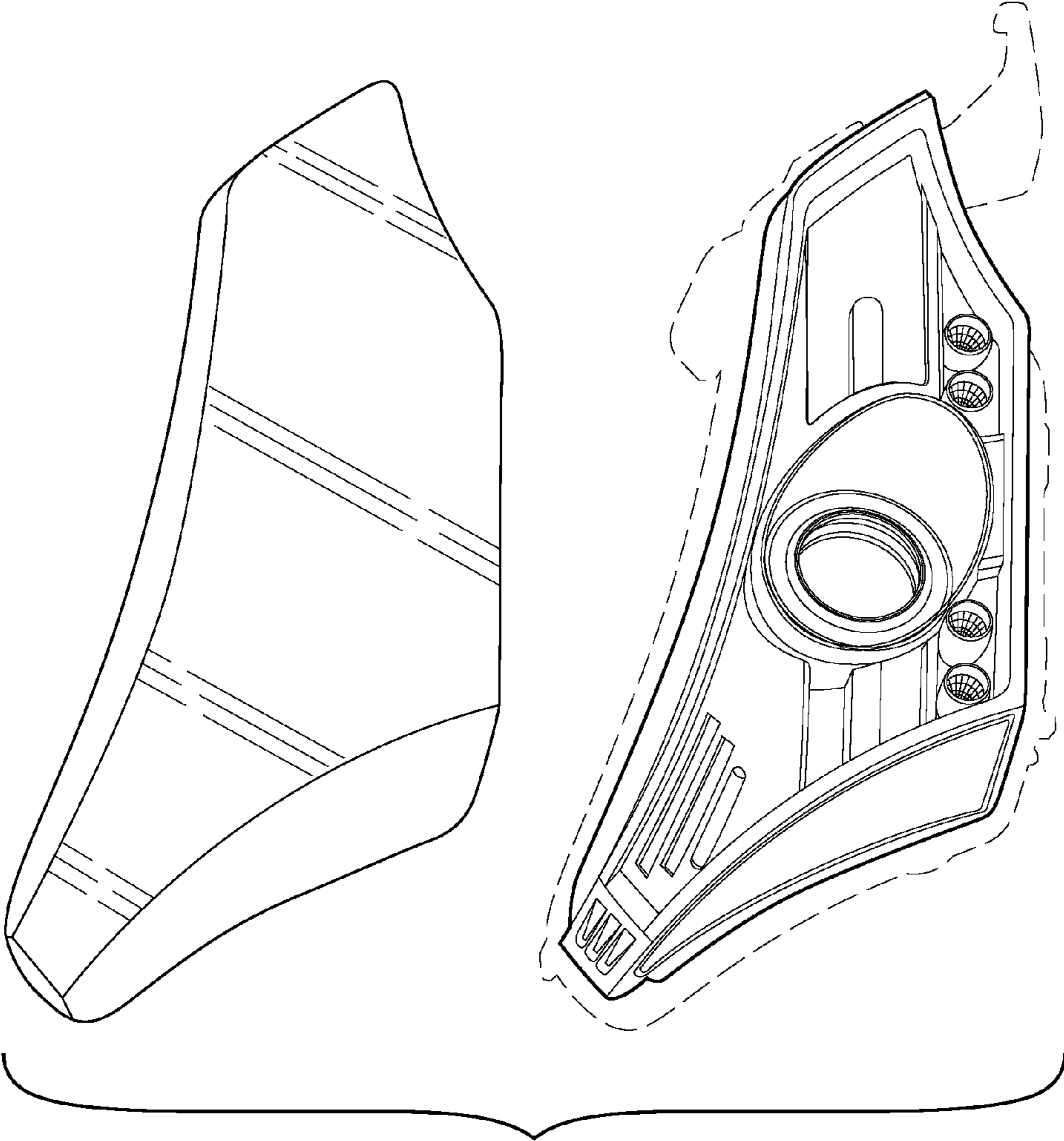

Fig. 5

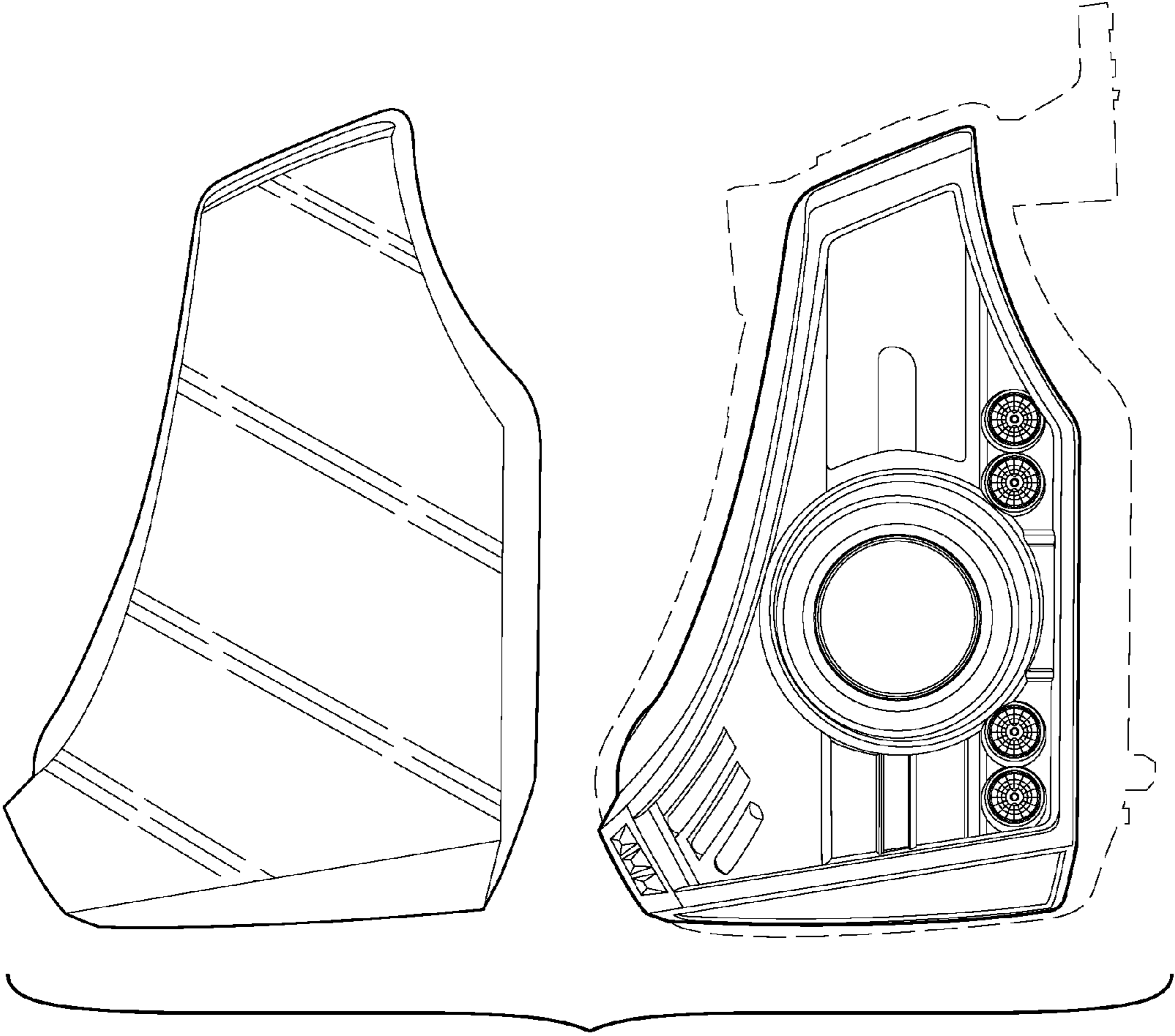

Fig. 6