



US00D592325S

(12) **United States Design Patent**
Bauer et al.

(10) **Patent No.:** **US D592,325 S**
(45) **Date of Patent:** **** May 12, 2009**

(54) **TAILLIGHT FOR A VEHICLE**

(75) Inventors: **Karlheinz Bauer**, Esslingen (DE);
Juergen Bollmann, Schoenberg (DE);
Gorden Wagener, Newport Coast, CA
(US)

(73) Assignee: **Daimler AG**, Stuttgart (DE)

(**) Term: **14 Years**

(21) Appl. No.: **29/300,644**

(22) Filed: **Apr. 22, 2008**

(30) **Foreign Application Priority Data**

Oct. 23, 2007 (DE) 40705293

(51) **LOC (9) Cl.** **26-06**

(52) **U.S. Cl.** **D26/28**

(58) **Field of Classification Search** D26/28-36;
362/459-468, 475-478, 485-487

See application file for complete search history.

(56) **References Cited**

U.S. PATENT DOCUMENTS

D549,363 S * 8/2007 Pfeiffer D26/28
D552,769 S * 10/2007 Leclercq D26/28
D553,269 S * 10/2007 Pfeiffer et al. D26/28
D553,368 S * 10/2007 Yee et al. D6/327

* cited by examiner

Primary Examiner—Marcus A. Jackson

(74) *Attorney, Agent, or Firm*—Crowell & Moring LLP

(57) **CLAIM**

The ornamental design for a taillight for a vehicle, as shown and described.

DESCRIPTION

This application is related to the following co-pending applications:

Application Ser. No. 29/300,647, entitled “Vehicle, Toy, or Likeness Thereof”;

Application Ser. No. 29/300,646, entitled “Rear Portion of a Vehicle, Toy, or Likeness Thereof”;

Application Ser. No. 29/300,643, entitled “Taillight for a Vehicle”;

Application Ser. No. 29/300,645, entitled “Taillight for a Vehicle”; and

Application Serial No. 29/287,947, entitled Vehicle, Toy, and/or Other Replicas.

FIG. 1 is a left perspective view of a first embodiment of a taillight for a vehicle according to our novel design;

FIG. 2 is a front view thereof;

FIG. 3 is a left side view thereof; and

FIG. 4 is a top view thereof.

FIG. 5 is a right perspective view of a second embodiment of the taillight for a vehicle according to our novel design;

FIG. 6 is a front view thereof;

FIG. 7 is a right side view thereof; and,

FIG. 8 is a top view thereof.

The broken lines are for illustrative purposes only and form no part of the claimed design.

1 Claim, 4 Drawing Sheets

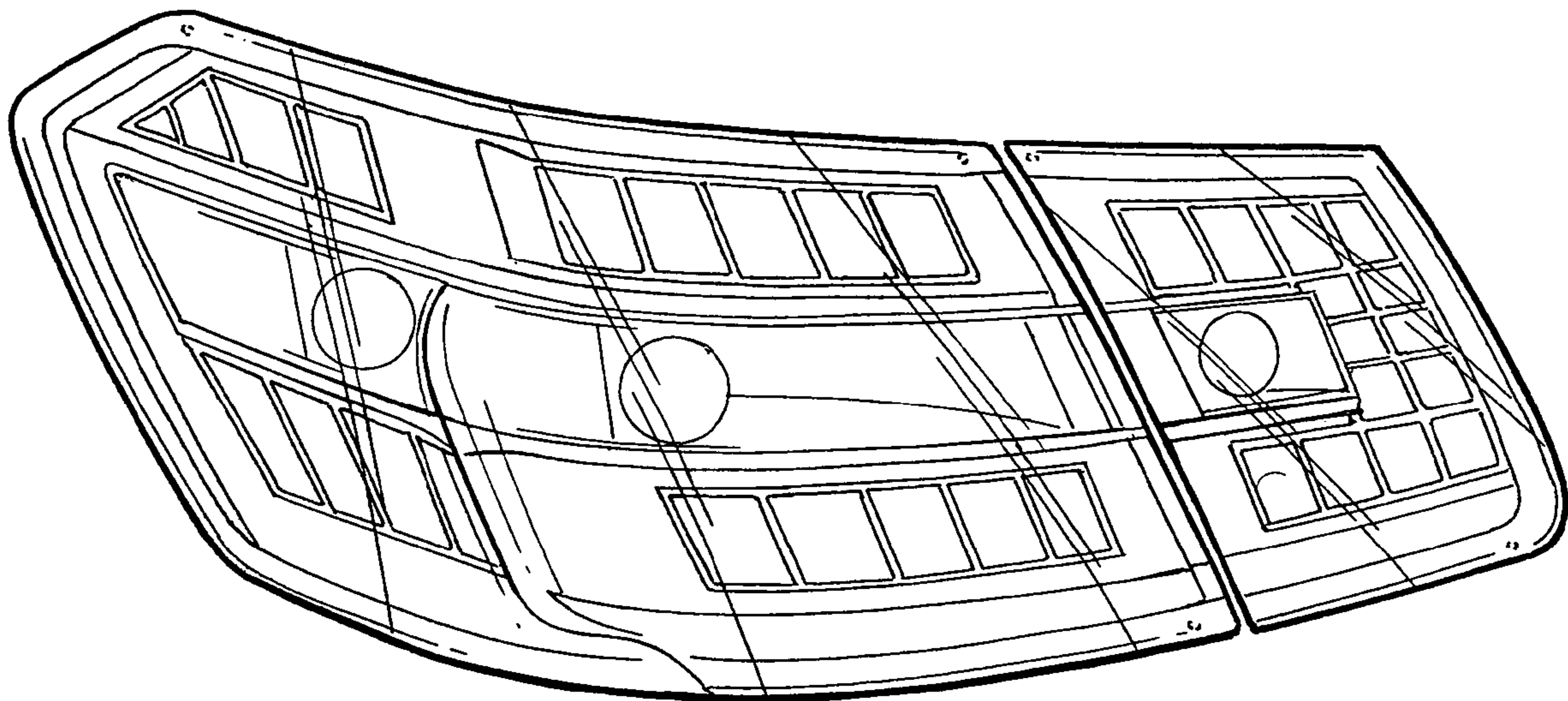

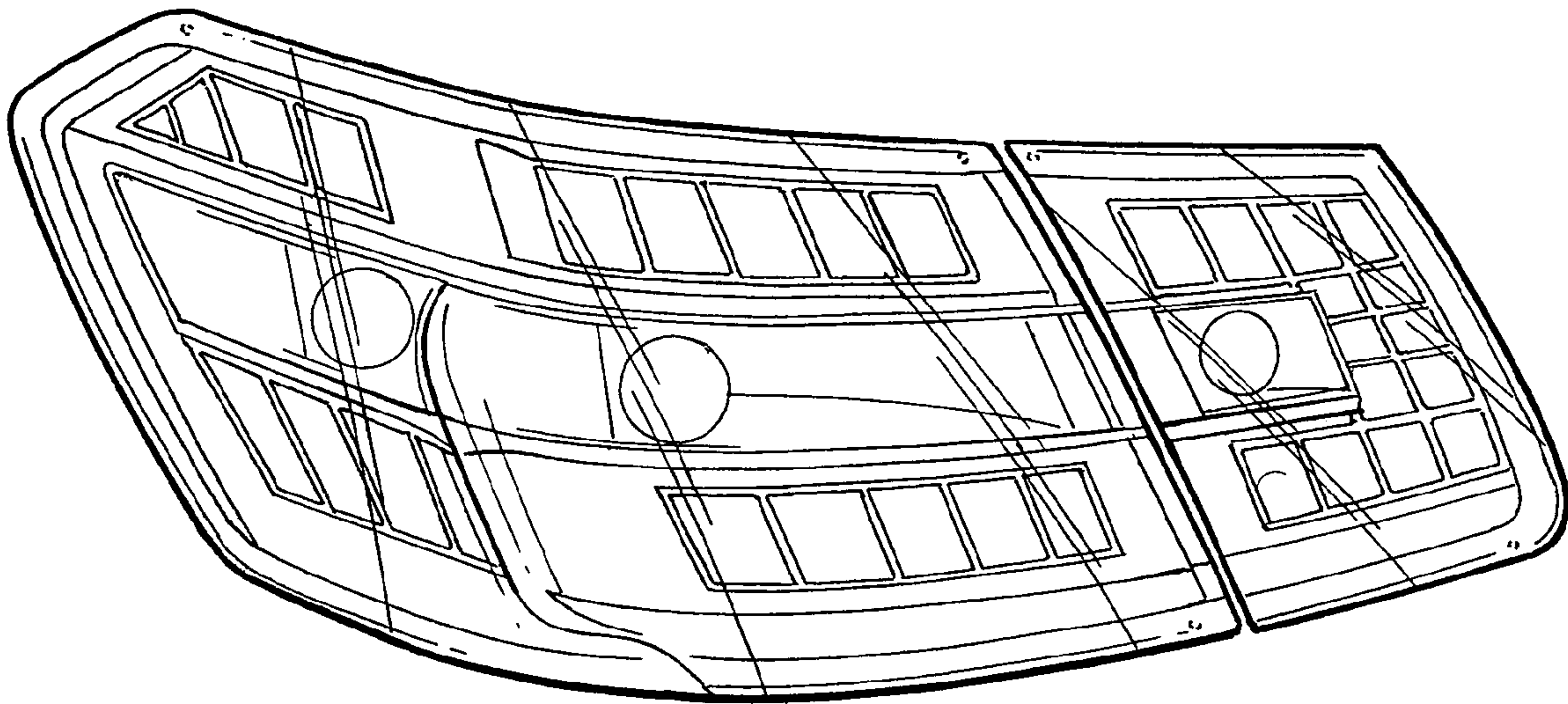

FIG. 1

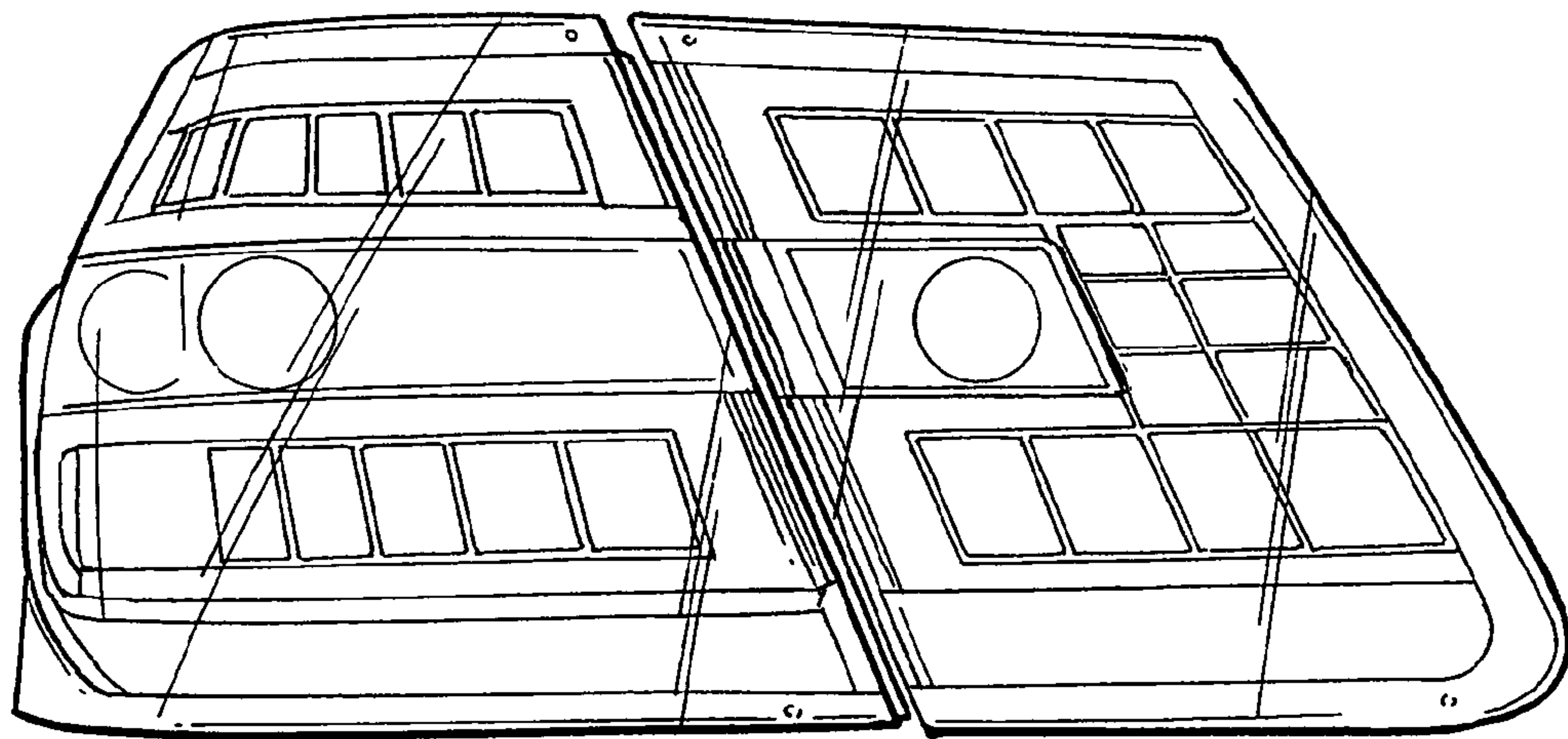

FIG. 2

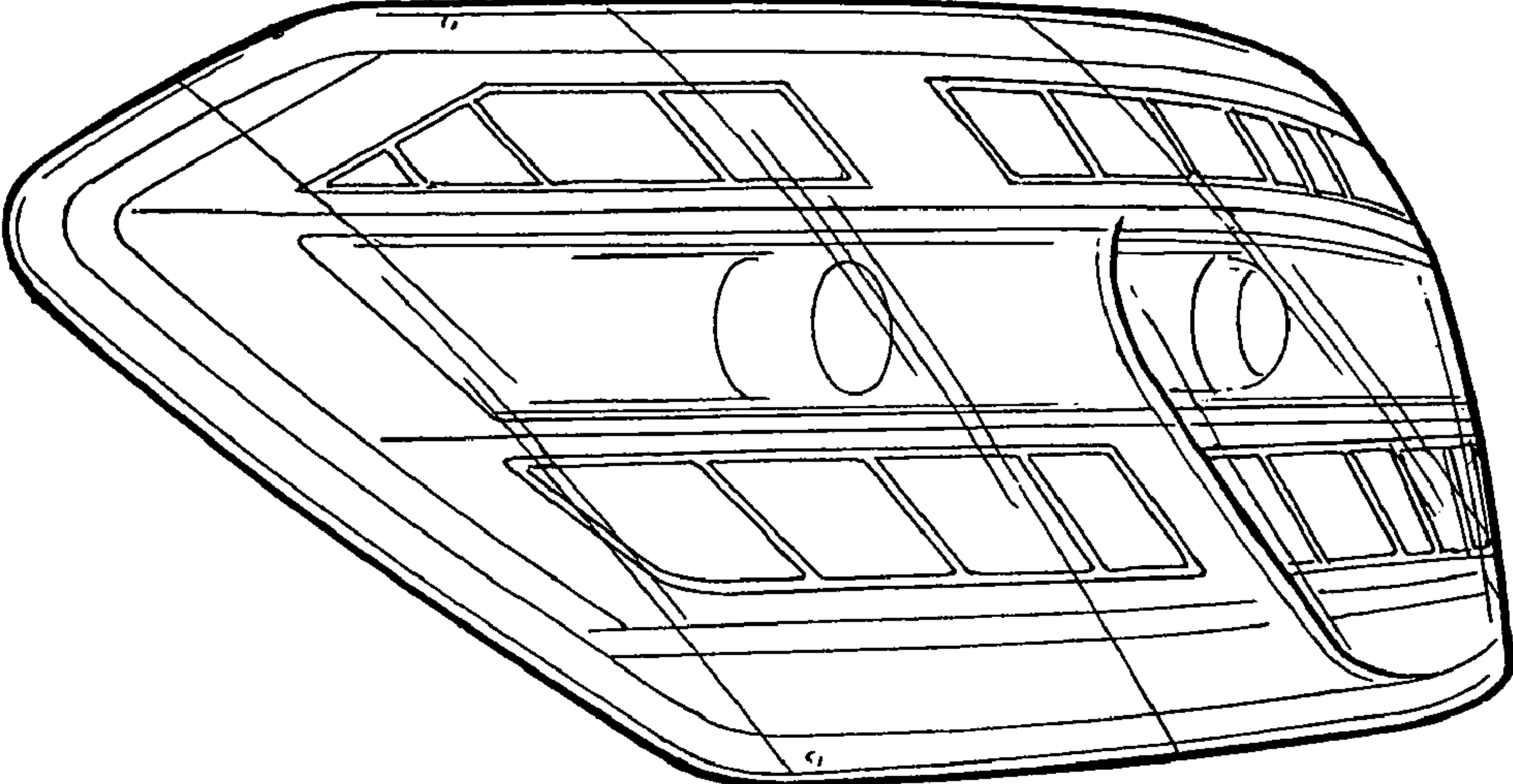

FIG. 3

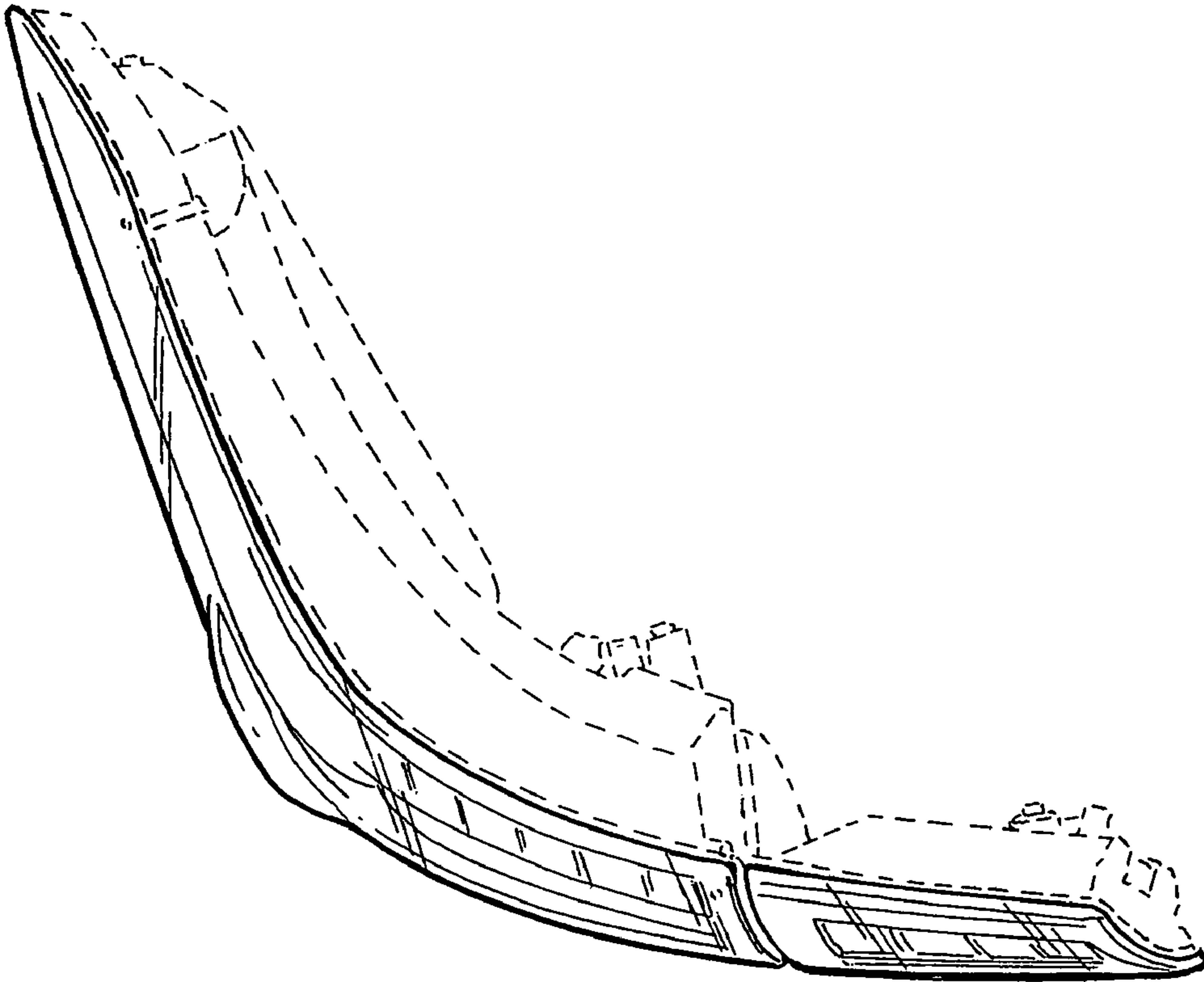

FIG. 4

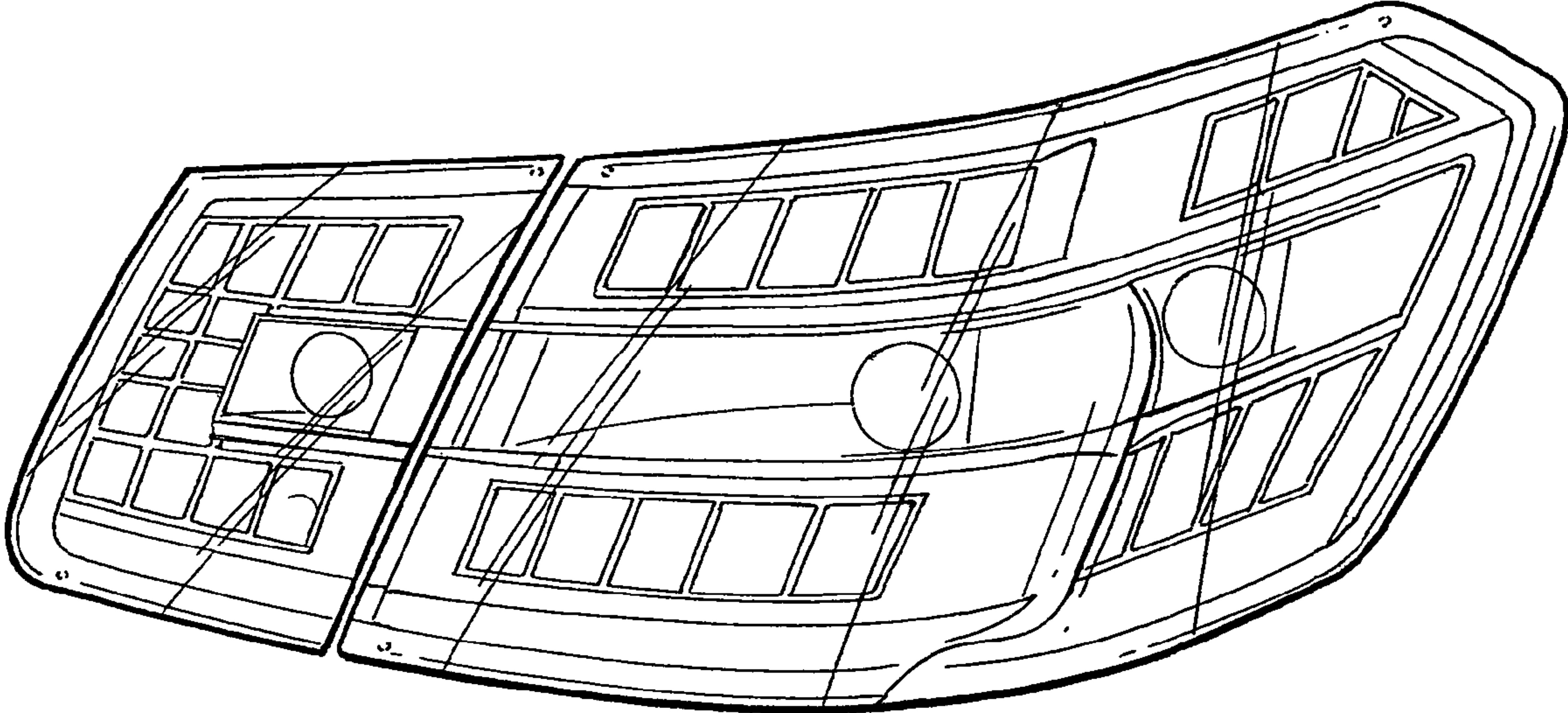

FIG. 5

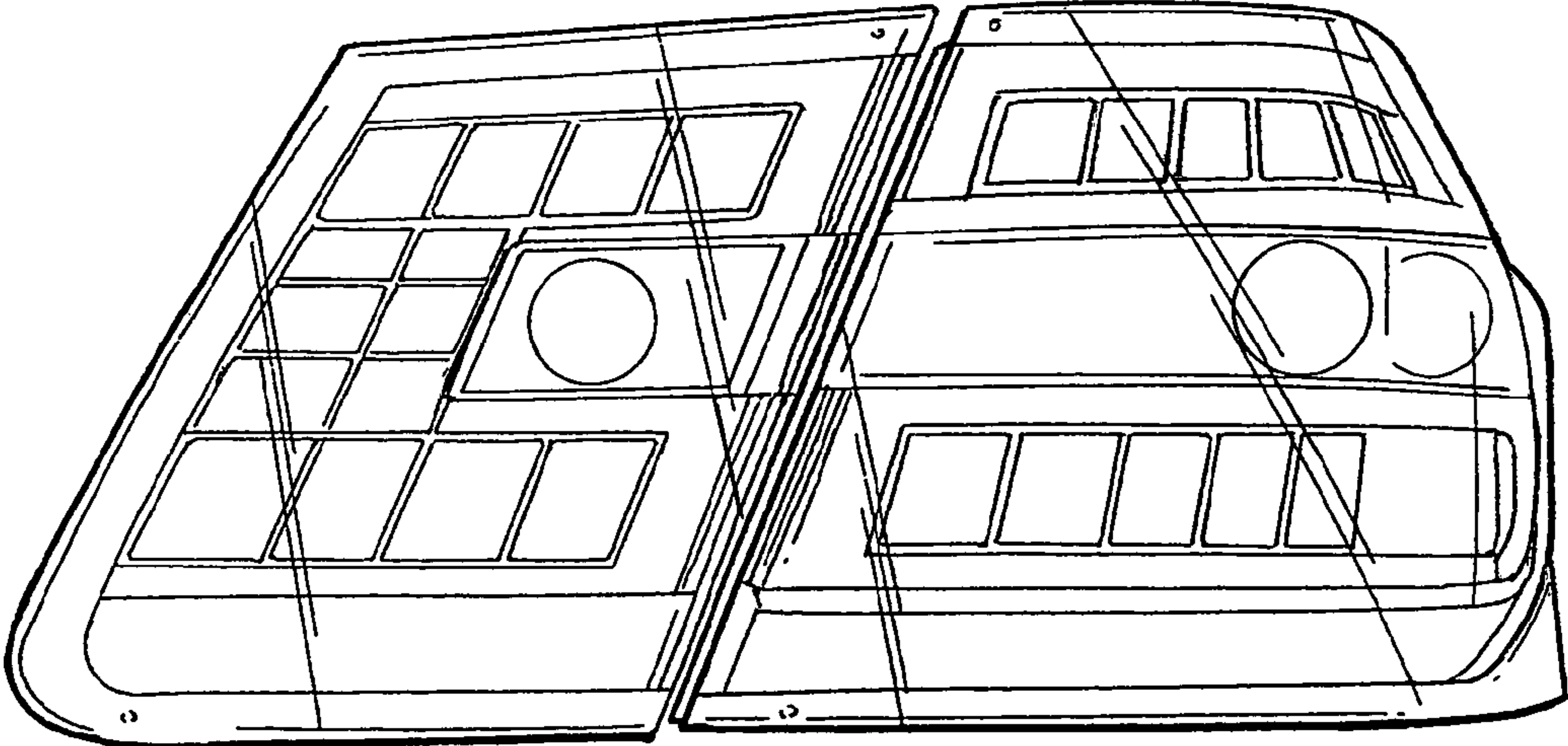

FIG. 6

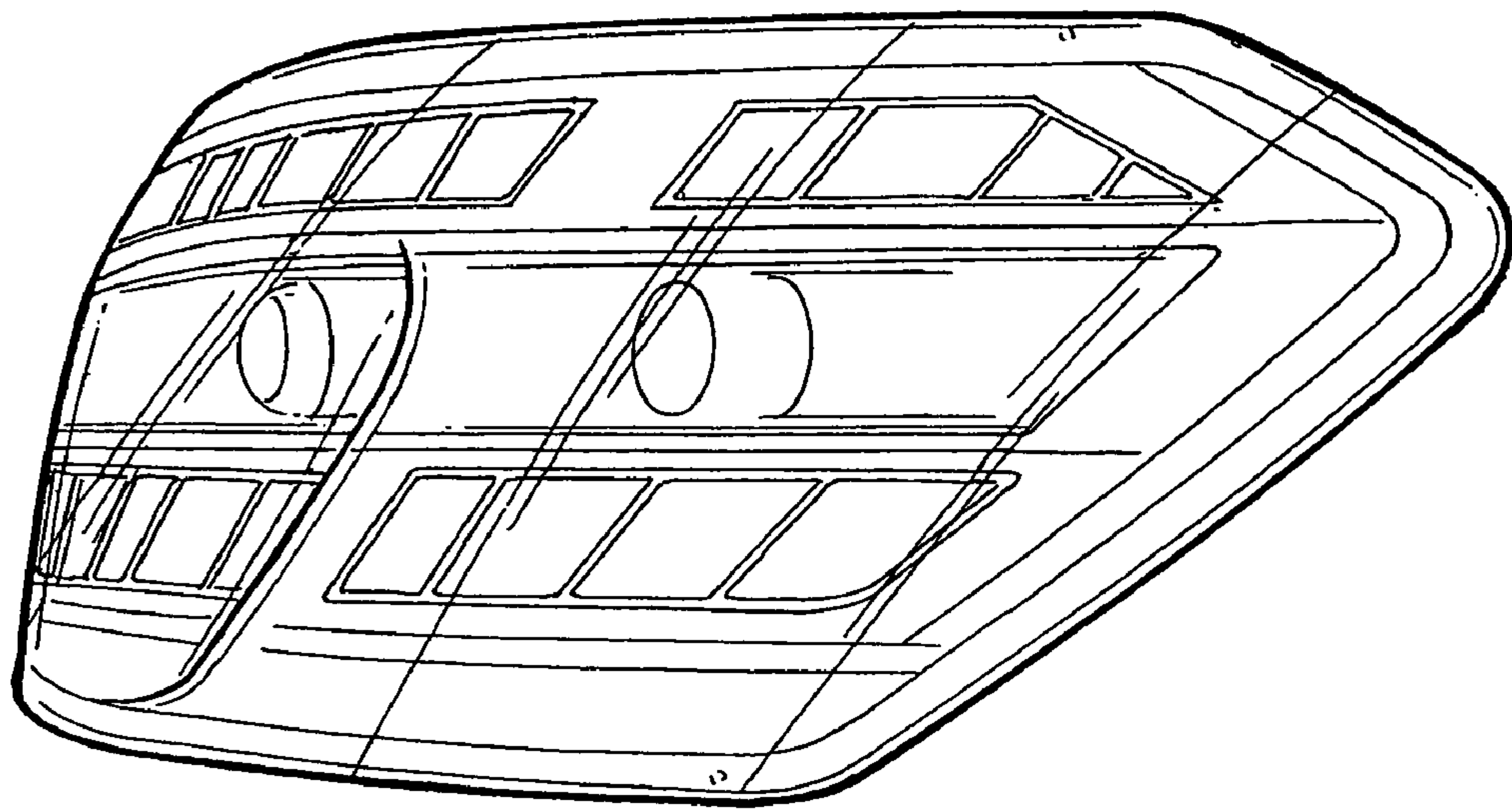

FIG. 7

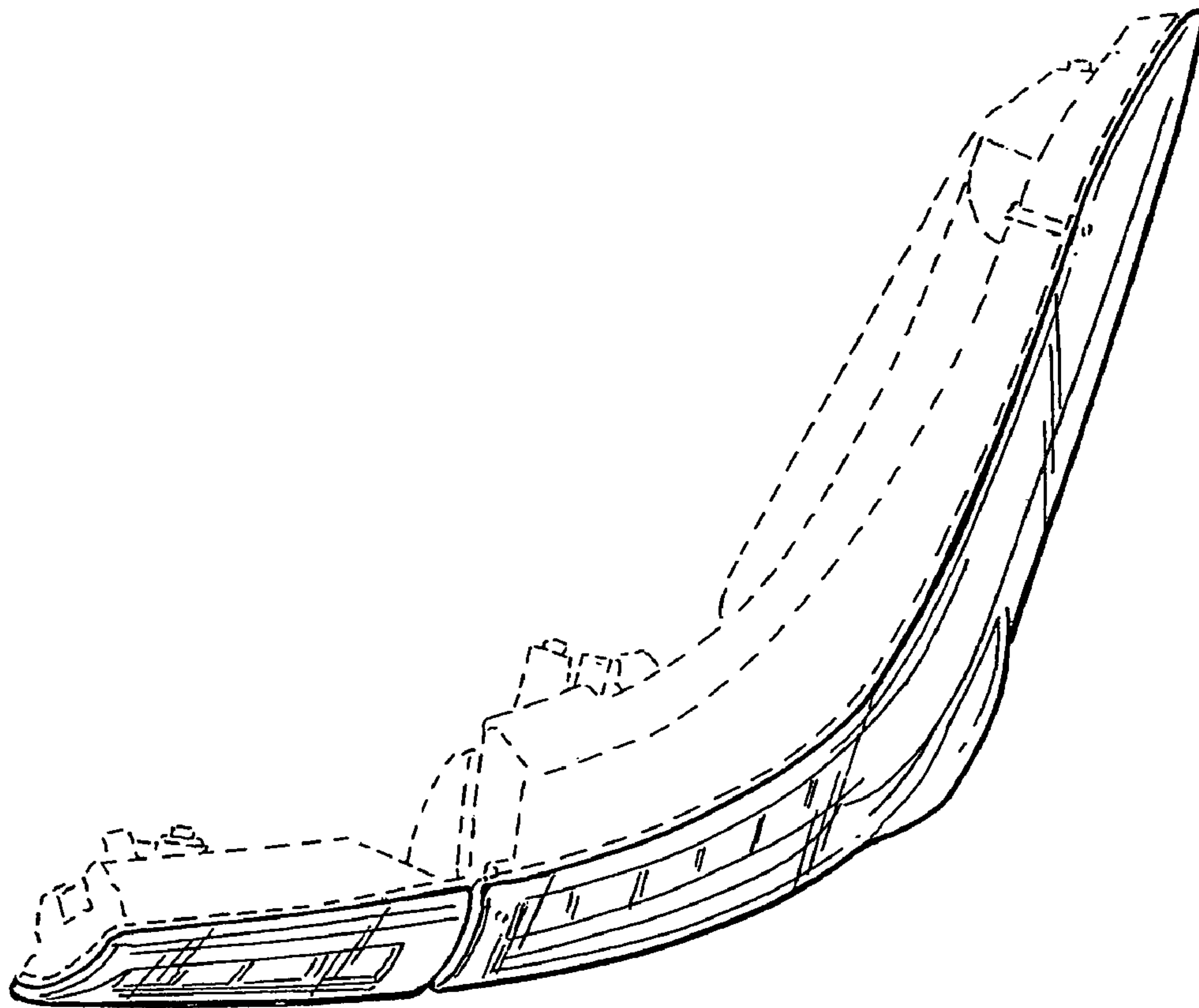

FIG. 8