



US00D592277S

(12) **United States Design Patent**
Yorns

(10) **Patent No.:** **US D592,277 S**

(45) **Date of Patent:** **** May 12, 2009**

(54) **WATER JET GUN**

(75) Inventor: **Mark W. Yorns**, Longmeadow, MA
(US)

(73) Assignee: **Guardair Corporation**, Chicopee, MA
(US)

(**) Term: **14 Years**

(21) Appl. No.: **29/323,199**

(22) Filed: **Aug. 20, 2008**

(51) **LOC (9) Cl.** **23-01**

(52) **U.S. Cl.** **D23/223; D23/226**

(58) **Field of Classification Search** **D23/213,**
D23/223, 226; 239/526, 600, 291

See application file for complete search history.

(56) **References Cited**

U.S. PATENT DOCUMENTS

2,320,964	A	6/1943	Yates	
2,604,361	A	7/1952	Yates	
2,783,092	A	2/1957	Gavin et al.	
3,780,949	A	12/1973	Gavin	
3,967,341	A	7/1976	Gavin	
5,176,327	A *	1/1993	Petersen et al.	239/526
5,782,414	A	7/1998	Nathenson	
5,860,232	A	1/1999	Nathenson et al.	
D408,830	S	4/1999	Nathenson et al.	
5,966,847	A	10/1999	Nathenson et al.	
D435,207	S	12/2000	Nathenson et al.	
6,158,152	A	12/2000	Nathenson et al.	
6,431,470	B2	8/2002	Berg	
D489,792	S *	5/2004	Chen	D23/223
6,915,967	B1 *	7/2005	Chen	239/530
D511,808	S *	11/2005	Chen	D23/223
D512,122	S	11/2005	Yorns et al.	
7,104,262	B2	9/2006	Yorns et al.	

7,216,816	B2 *	5/2007	Hammarth et al.	239/106
D561,874	S	2/2008	Downey et al.	
D564,069	S	3/2008	Yorns et al.	
D565,153	S	3/2008	Downey et al.	
7,389,949	B2 *	6/2008	Marchand et al.	239/526
2005/0098691	A1	5/2005	Yorns et al.	
2005/0218285	A1	10/2005	Yorns et al.	

OTHER PUBLICATIONS

Brochure for Guardair Corp. Force 5 Air gun, which was first offered for sale as early as Apr. 1, 2005.

* cited by examiner

Primary Examiner—Robin V Webster

(74) *Attorney, Agent, or Firm*—Scott E. Kamholz; Foley Hoag LLP

(57) **CLAIM**

The ornamental design for a water jet gun, as shown and described.

DESCRIPTION

FIG. 1 is a perspective view of a water jet gun showing the design;

FIG. 2 is a top plan view thereof;

FIG. 3 is a bottom plan view thereof;

FIG. 4 is a side elevation view thereof, the other side being a mirror image thereof;

FIG. 5 is a front elevation view of the design; and,

FIG. 6 is a rear elevation view thereof.

Broken lines shown in the drawings are for illustrative purposes only and do not form part of the claimed design. Shading is provided to illustrate contour and not to indicate surface color, texture, or finish.

1 Claim, 2 Drawing Sheets

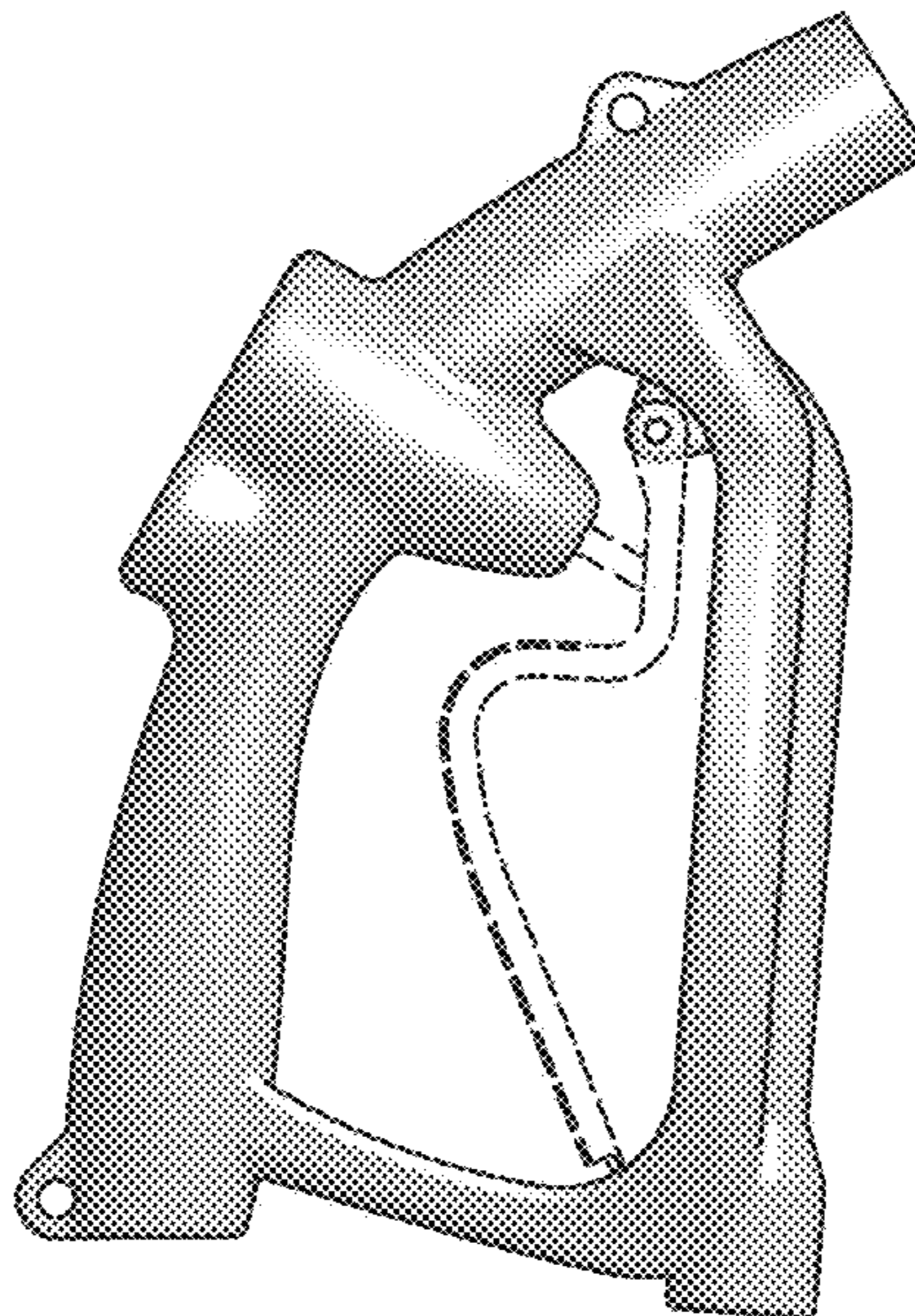

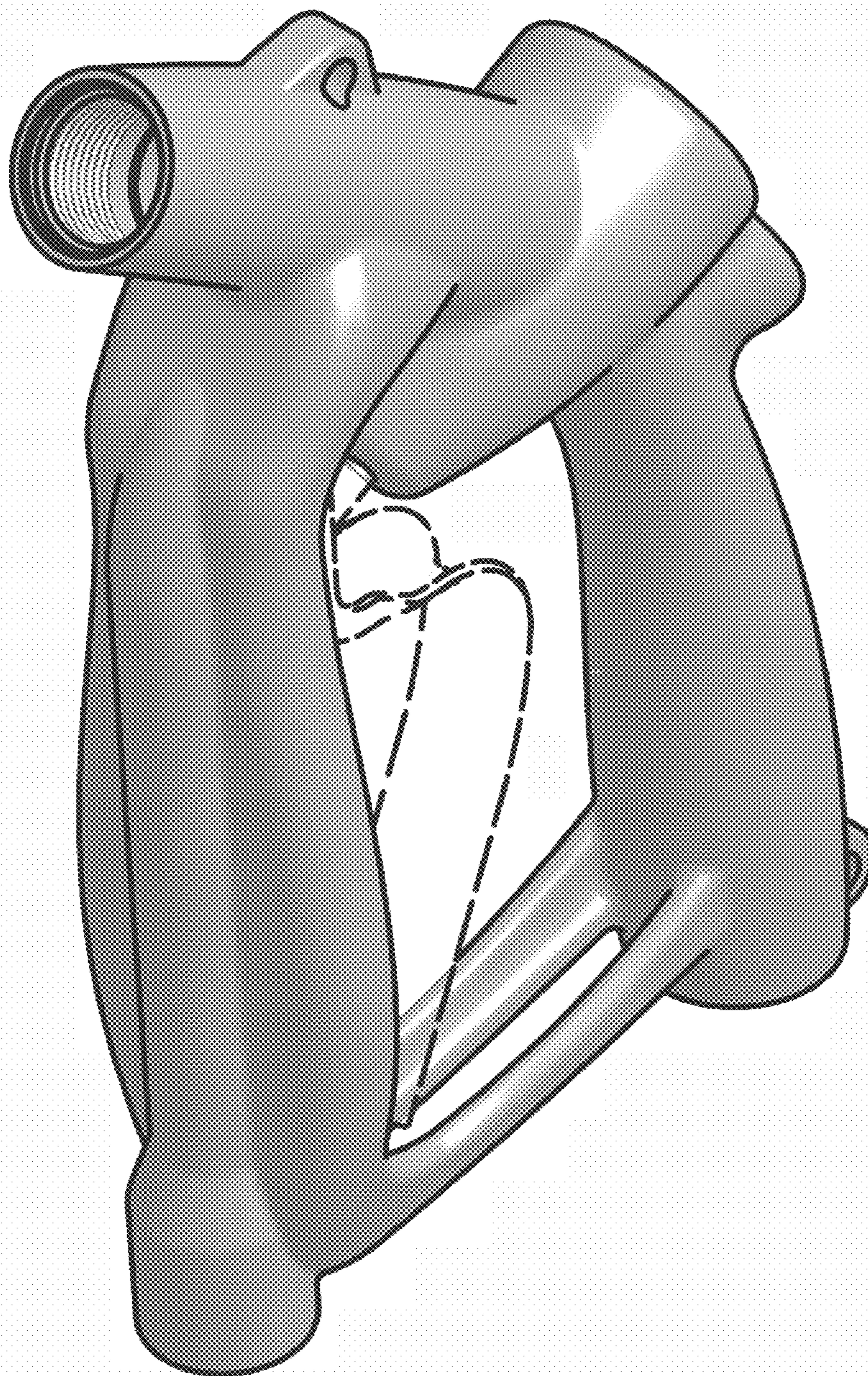

FIG. 1

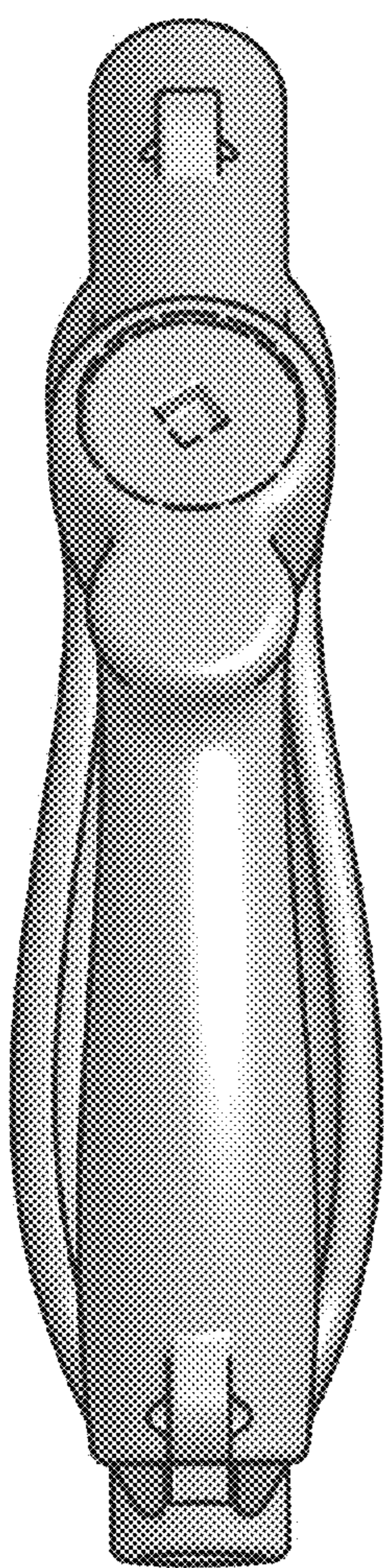
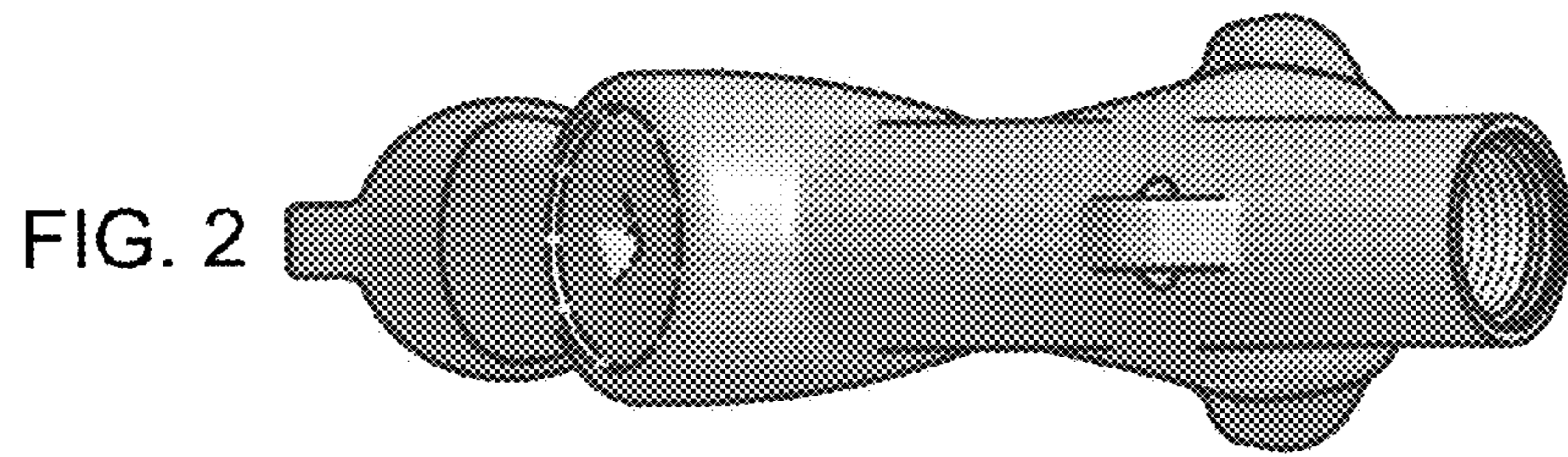

FIG. 6

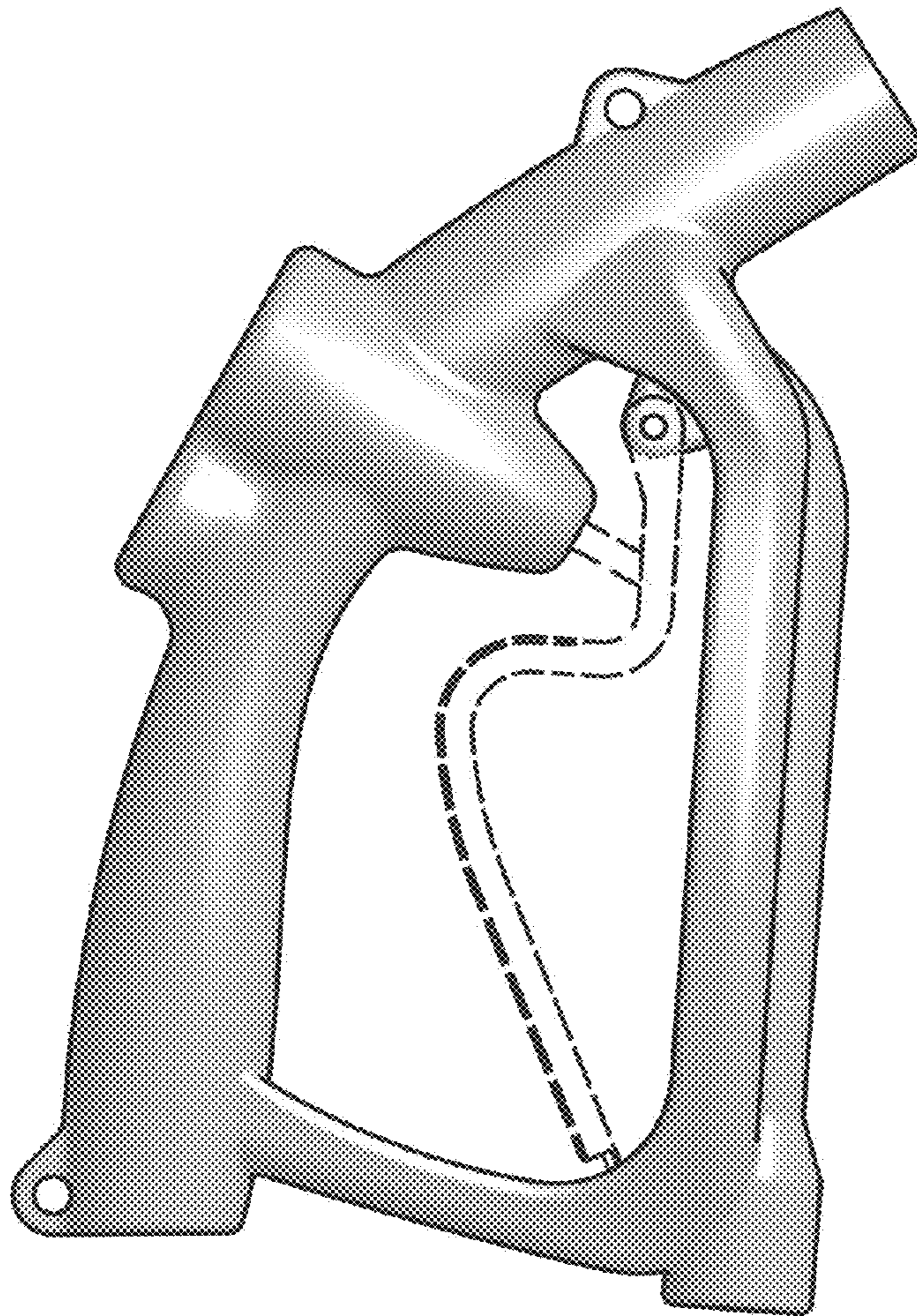

FIG. 4

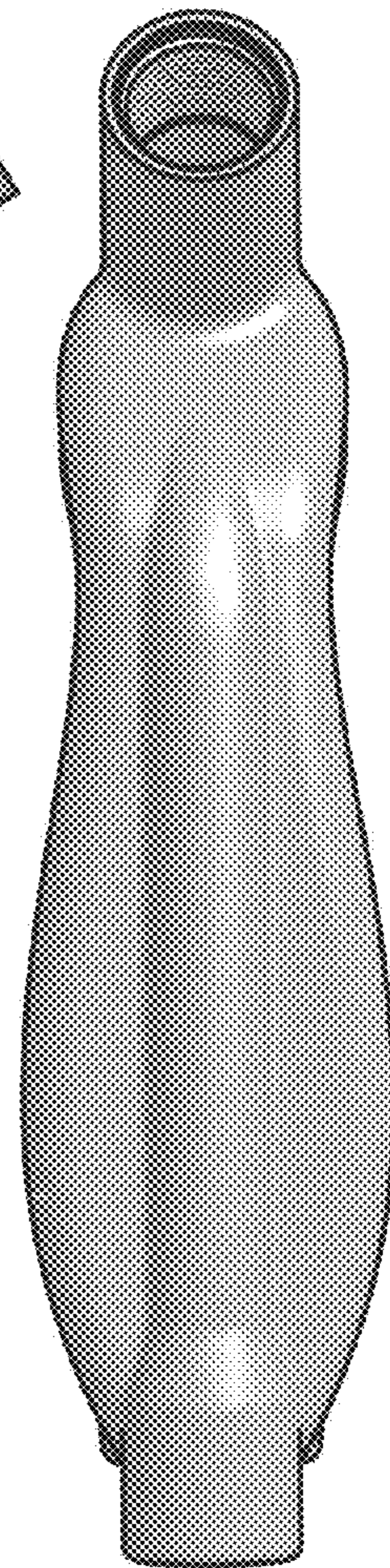

FIG. 5

