



US00D592121S

(12) **United States Design Patent**
Bratec et al.

(10) **Patent No.:** **US D592,121 S**

(45) **Date of Patent:** **** May 12, 2009**

(54) **SPOILER FOR WINDSHIELD WIPER**

2006/0207050 A1* 9/2006 Shanmugham et al. ... 15/250.43
2009/0025174 A1* 1/2009 Braun et al. 15/250.48

(75) Inventors: **Hervé Bratec**, Wilsela (BE); **Christian Wilms**, Koersel-Beringen (BE)

* cited by examiner

(73) Assignee: **Robert Bosch GmbH**, Stuttgart (DE)

Primary Examiner—Caron Veynar

Assistant Examiner—Katrina A Kile

(**) Term: **14 Years**

(74) *Attorney, Agent, or Firm*—Victor A. Henzi

(21) Appl. No.: **29/330,752**

(57) **CLAIM**

(22) Filed: **Jan. 14, 2009**

The ornamental design for a spoiler for windshield wiper, as shown and described.

(51) **LOC (9) Cl.** **12-16**

(52) **U.S. Cl.** **D12/220**

(58) **Field of Classification Search** D12/219–220;
15/246, 247, 250.001, 250.04, 250.361, 250.19,
15/250.48, 250.03, 250.31–250.33, 250.351,
15/250.38, 250.201, 250.451, 250.458, 250.07,
15/250.44

See application file for complete search history.

DESCRIPTION

FIG. 1. is a top left front perspective view of the spoiler for windshield wiper;

FIG. 2 is a front elevational view thereof;

FIG. 3 is a rear elevational view thereof;

FIG. 4 is a left elevational view thereof;

FIG. 5 is a right elevational view thereof;

FIG. 6 is a bottom plan view thereof; and,

FIG. 7 is a top plan view thereof.

The spoiler for windshield wiper is shown broken away in the middle section of FIGS. 1, 4, 5, 6 and 7 to indicate indeterminate length.

(56) **References Cited**

U.S. PATENT DOCUMENTS

D365,320 S *	12/1995	Franz	D12/220
6,836,924 B2 *	1/2005	Egan-Walter	15/250.04
D564,955 S *	3/2008	Claes	D12/220
7,464,433 B2 *	12/2008	Thomar et al.	15/250.201
2003/0019066 A1 *	1/2003	Egner-Walter	15/250.04

1 Claim, 4 Drawing Sheets

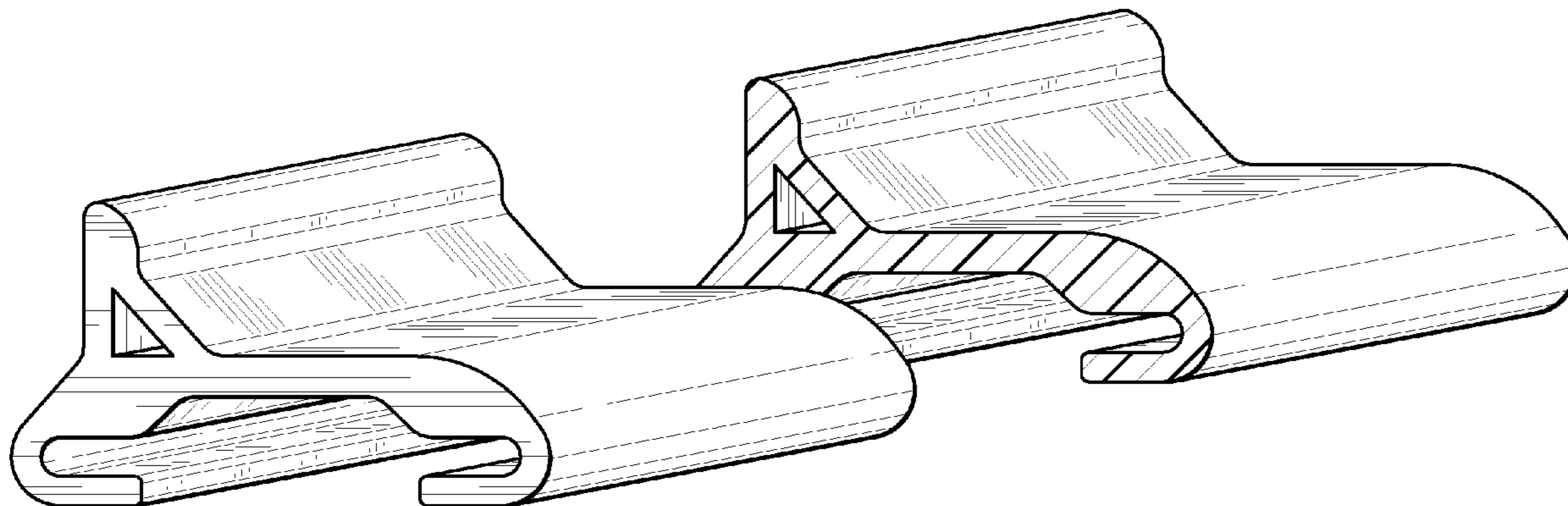

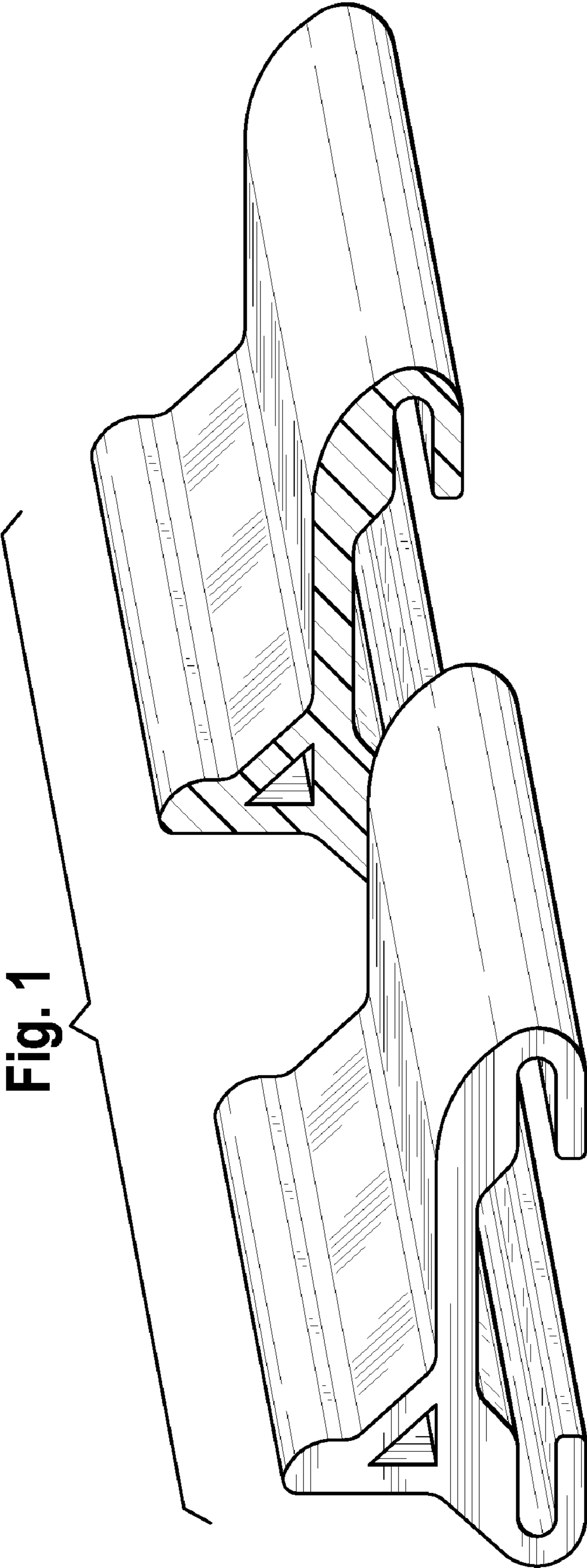

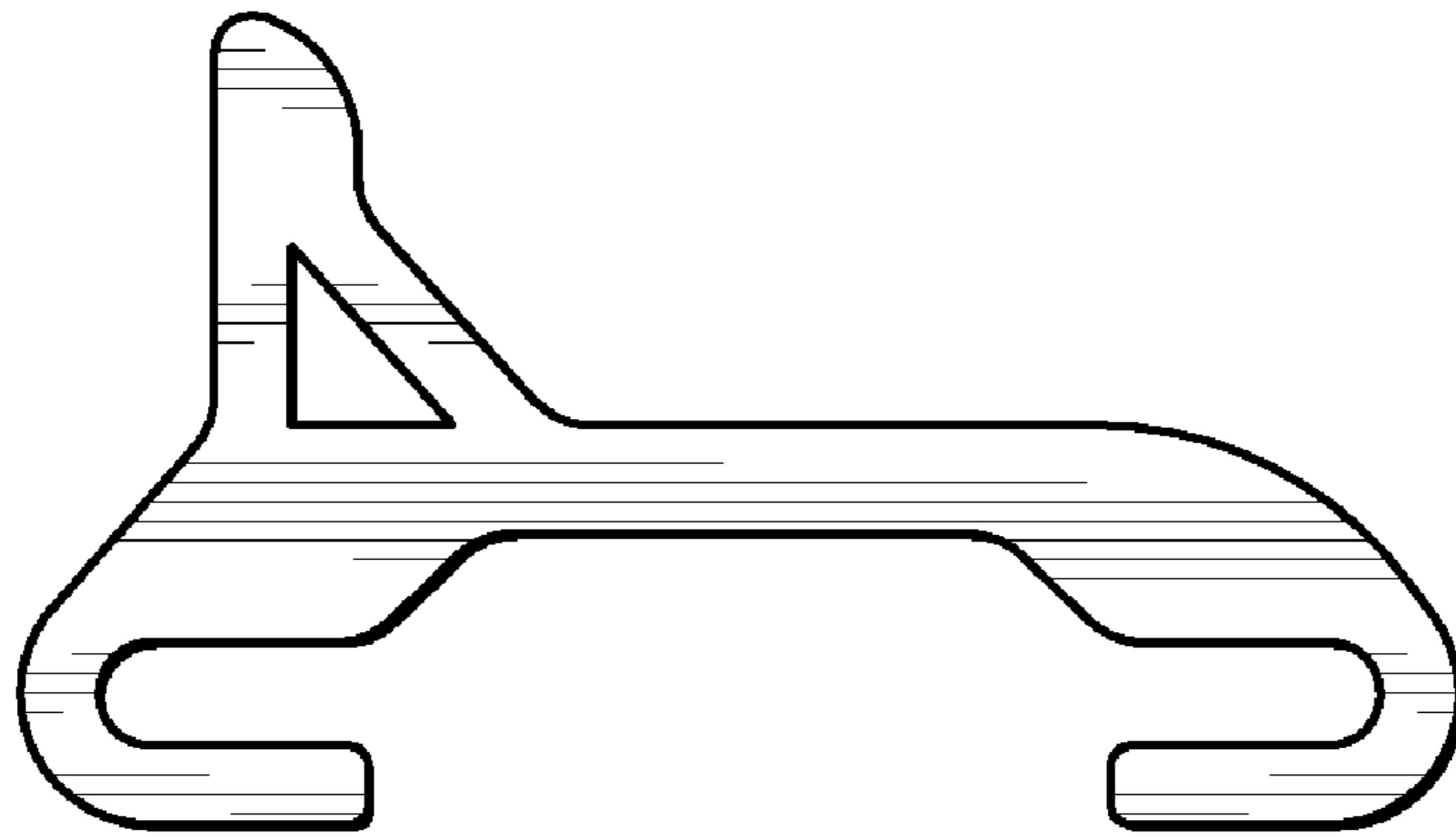

Fig. 2

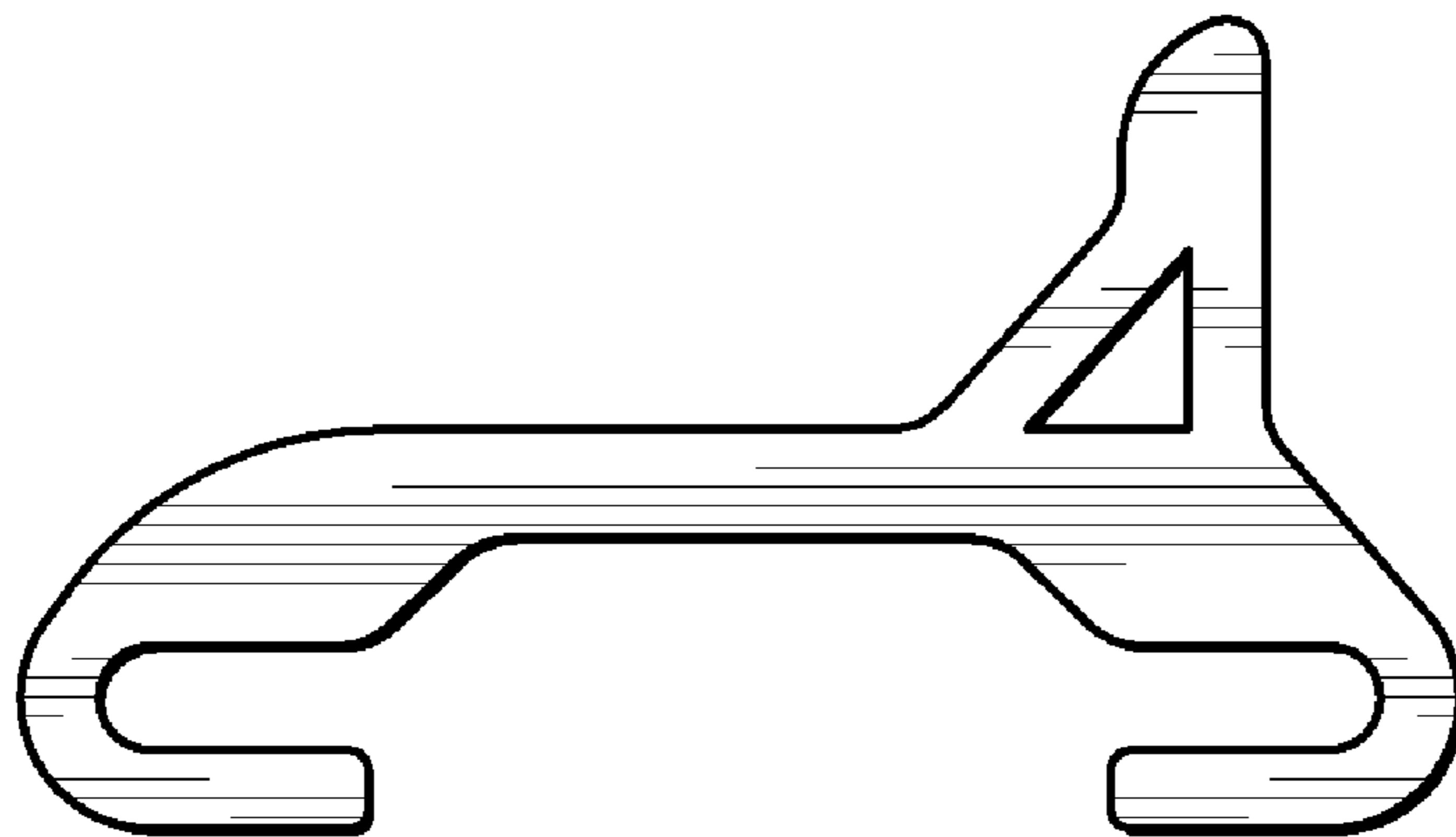

Fig. 3

Fig. 4

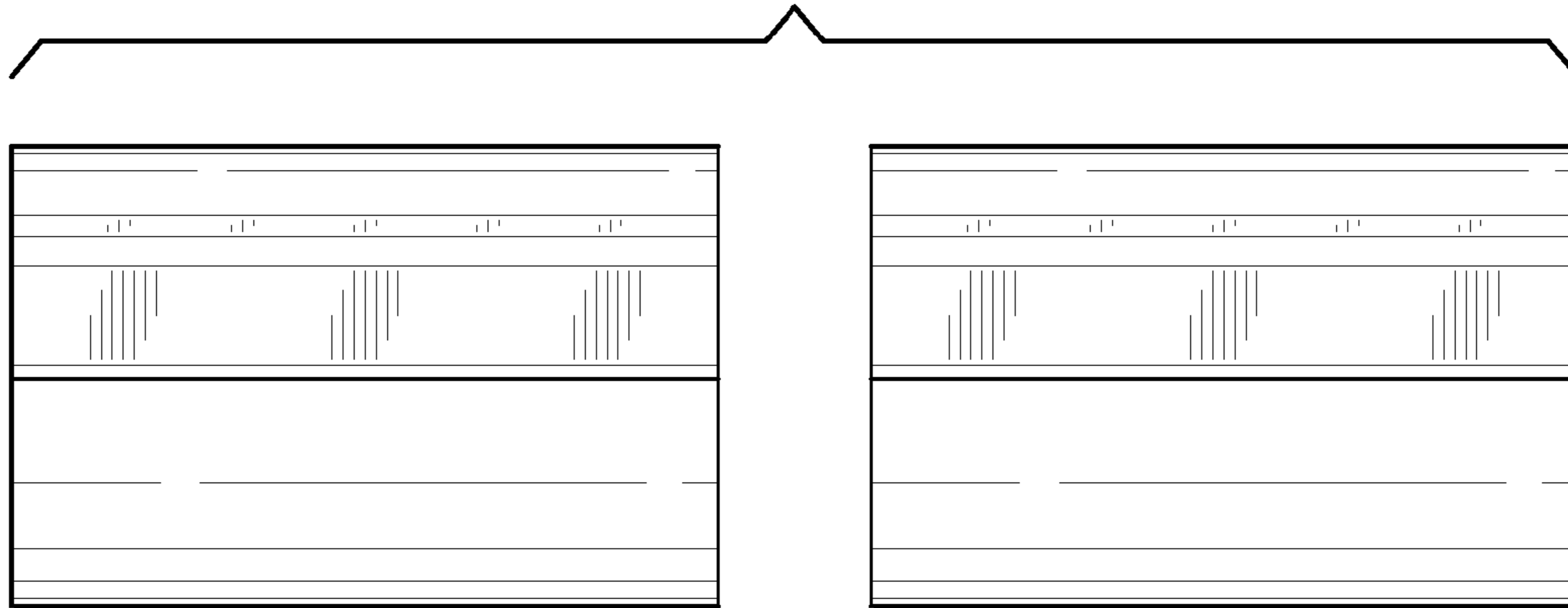

Fig. 5

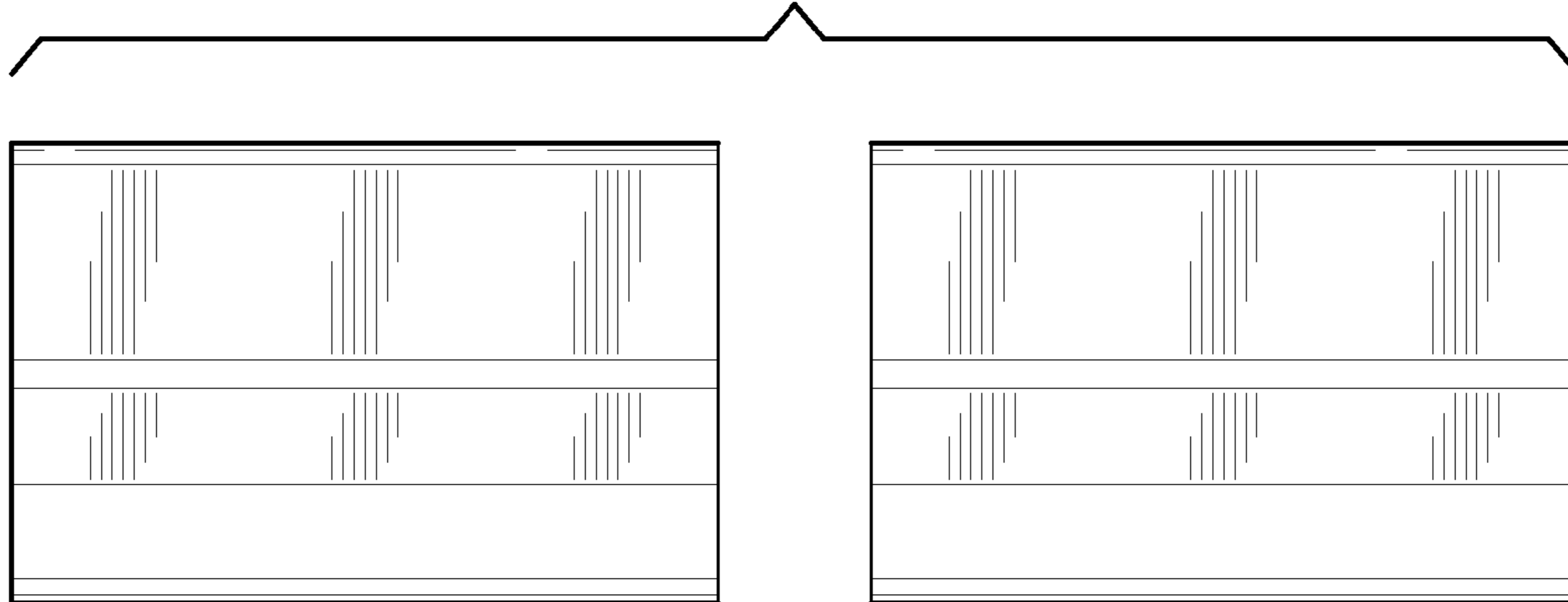

Fig. 6

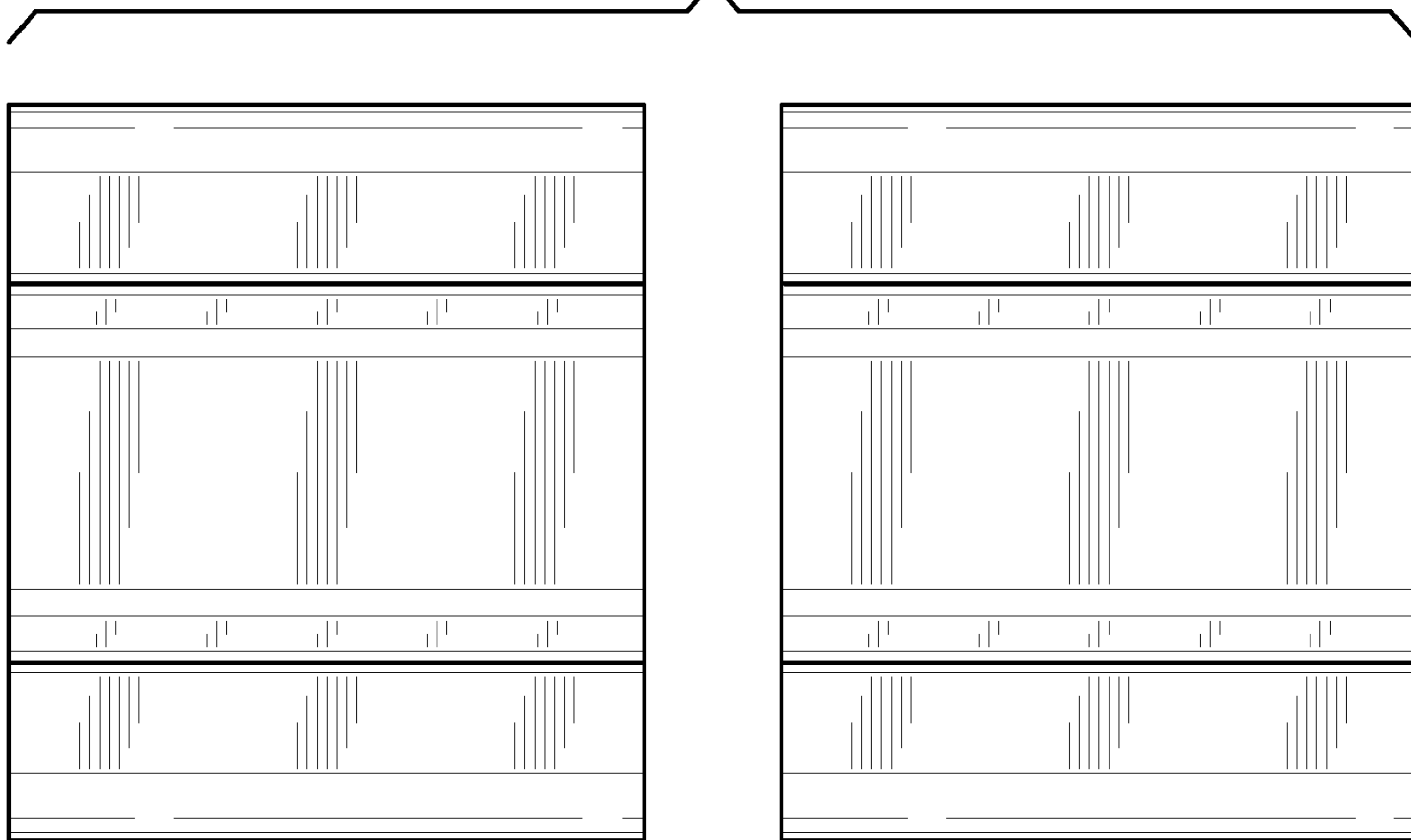

Fig. 7

