



US00D592041S

(12) **United States Design Patent**
Drolet

(10) **Patent No.:** **US D592,041 S**
(45) **Date of Patent:** **** May 12, 2009**

(54) **VEHICLE AIR VENT MOUNTING DEVICE FOR SUPPORTING A GPS UNIT**

Primary Examiner—Holly H Baynham
(74) *Attorney, Agent, or Firm*—Robert J Doherty

(76) Inventor: **Rudolphe Drolet**, 35 Bradley St., Woonsocket, RI (US) 02895

(57) **CLAIM**

(**) Term: **14 Years**

The ornamental design for a vehicle air vent mounting device for supporting a GPS unit, as shown and described.

(21) Appl. No.: **29/307,735**

DESCRIPTION

(22) Filed: **May 9, 2008**

(51) **LOC (9) Cl.** **08-05**

(52) **U.S. Cl.** **D8/373**

(58) **Field of Classification Search** D8/367,
D8/373; 248/301–304

See application file for complete search history.

FIG. 1 is a front perspective view of a vehicle air vent mounting device for supporting a GPS unit, showing my new design;

FIG. 2 is a front perspective view of the device removed from its use environment;

FIG. 3 is a front elevational view thereof;

FIG. 4 is a rear elevational view thereof;

FIG. 5 is a right side elevational view thereof;

FIG. 6 is a left side elevational view thereof;

FIG. 7 is a top plan view thereof; and,

FIG. 8 is a bottom plan view thereof.

The broken lines shown in FIG. 1 are for illustrative purposes and form no part of the claimed design.

(56) **References Cited**

U.S. PATENT DOCUMENTS

D431,451 S *	10/2000	Kuo	D8/373
D449,977 S *	11/2001	Dembowski et al.	D8/367
D482,952 S *	12/2003	Steinman	D8/373
2003/0189147 A1 *	10/2003	Immerman	248/304

* cited by examiner

1 Claim, 4 Drawing Sheets

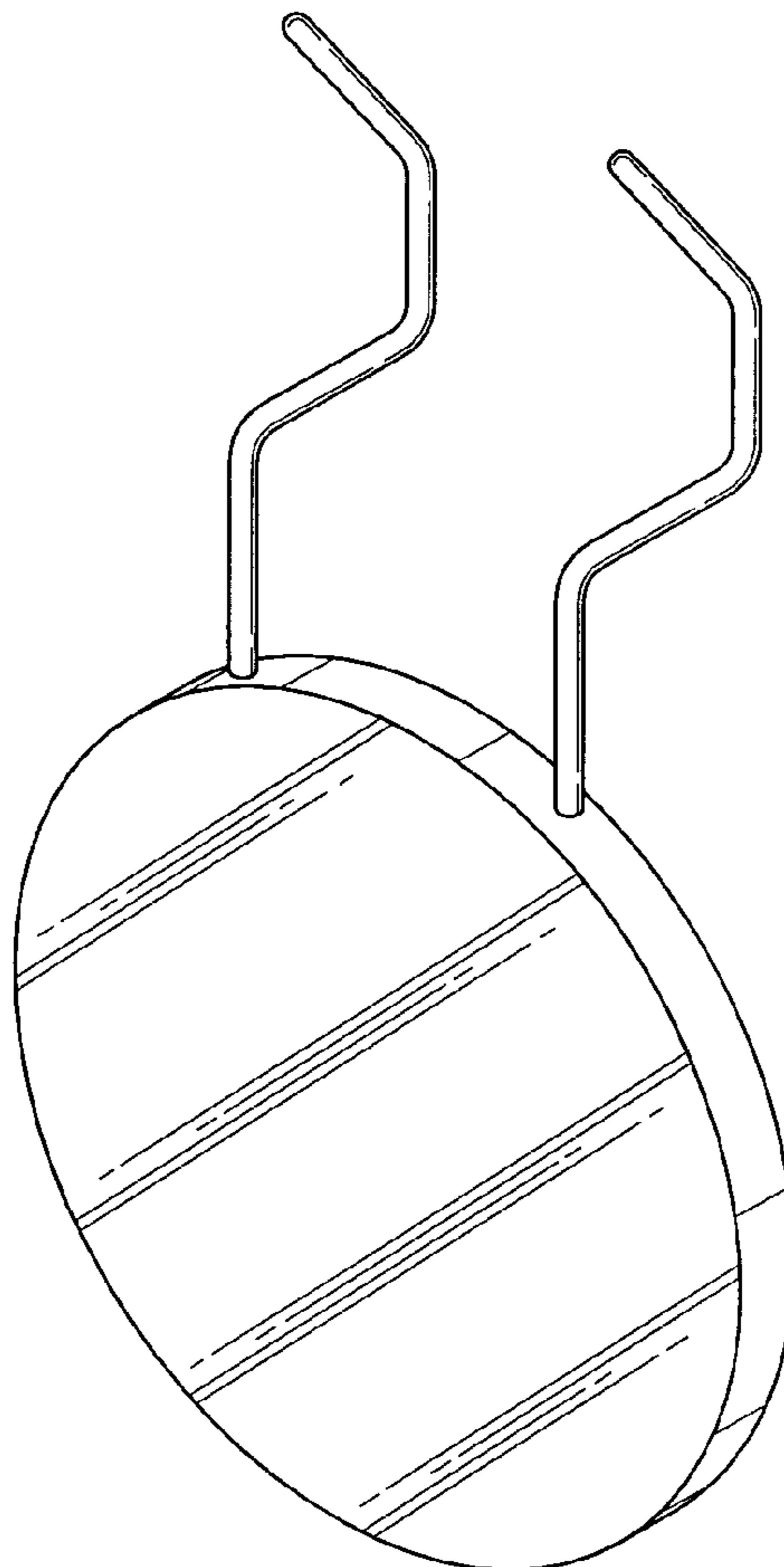

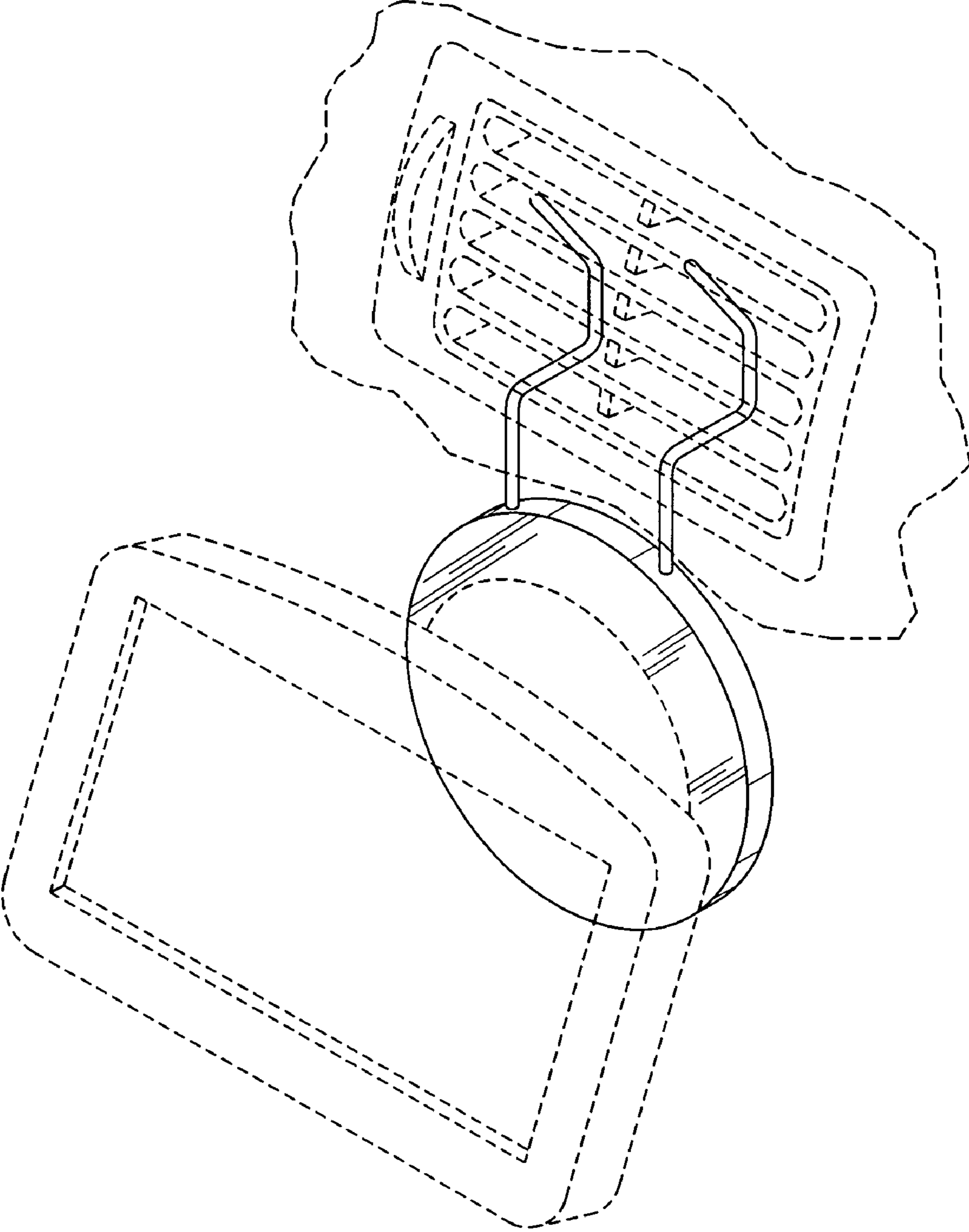

FIG. 1

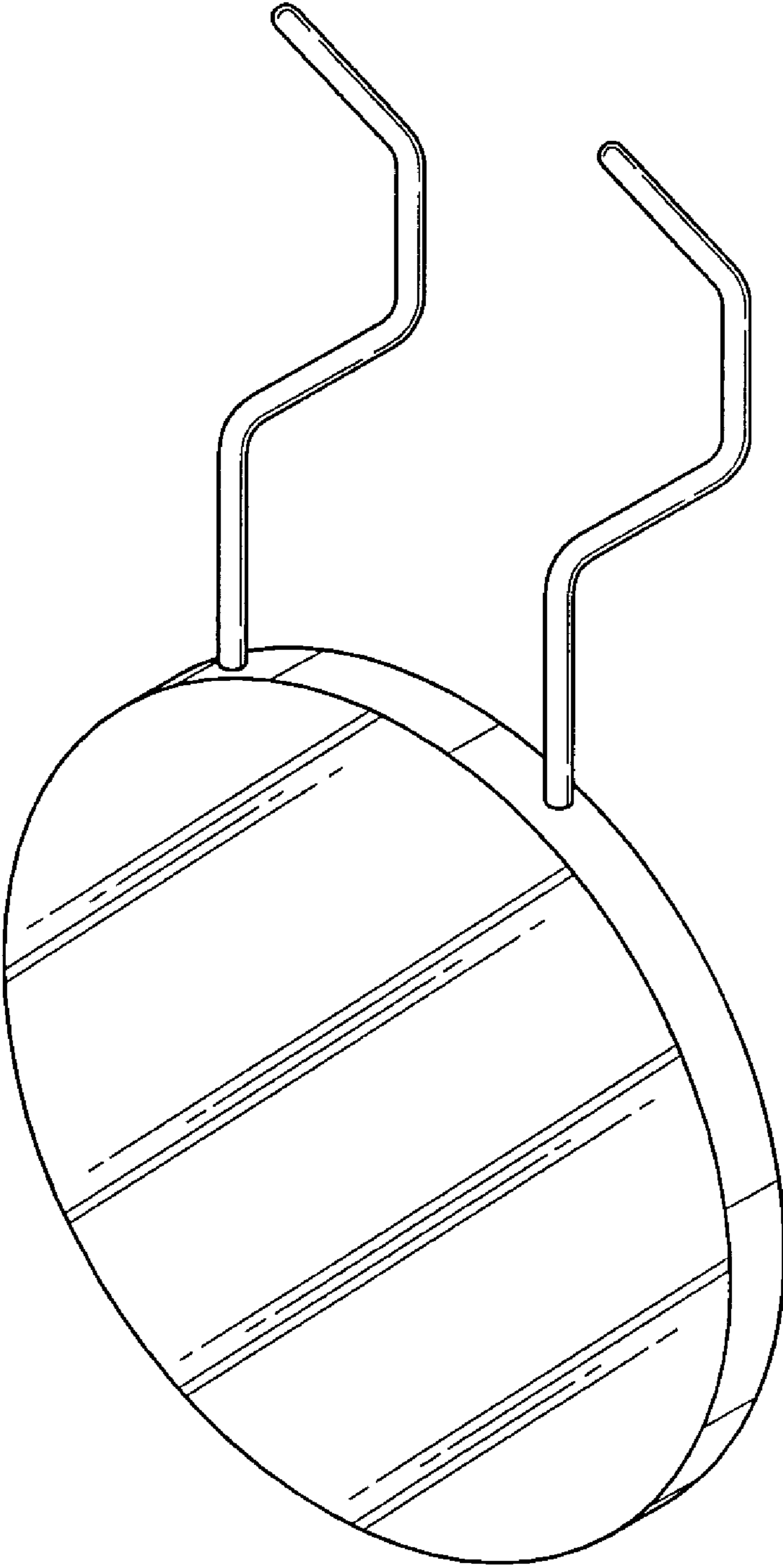

FIG. 2

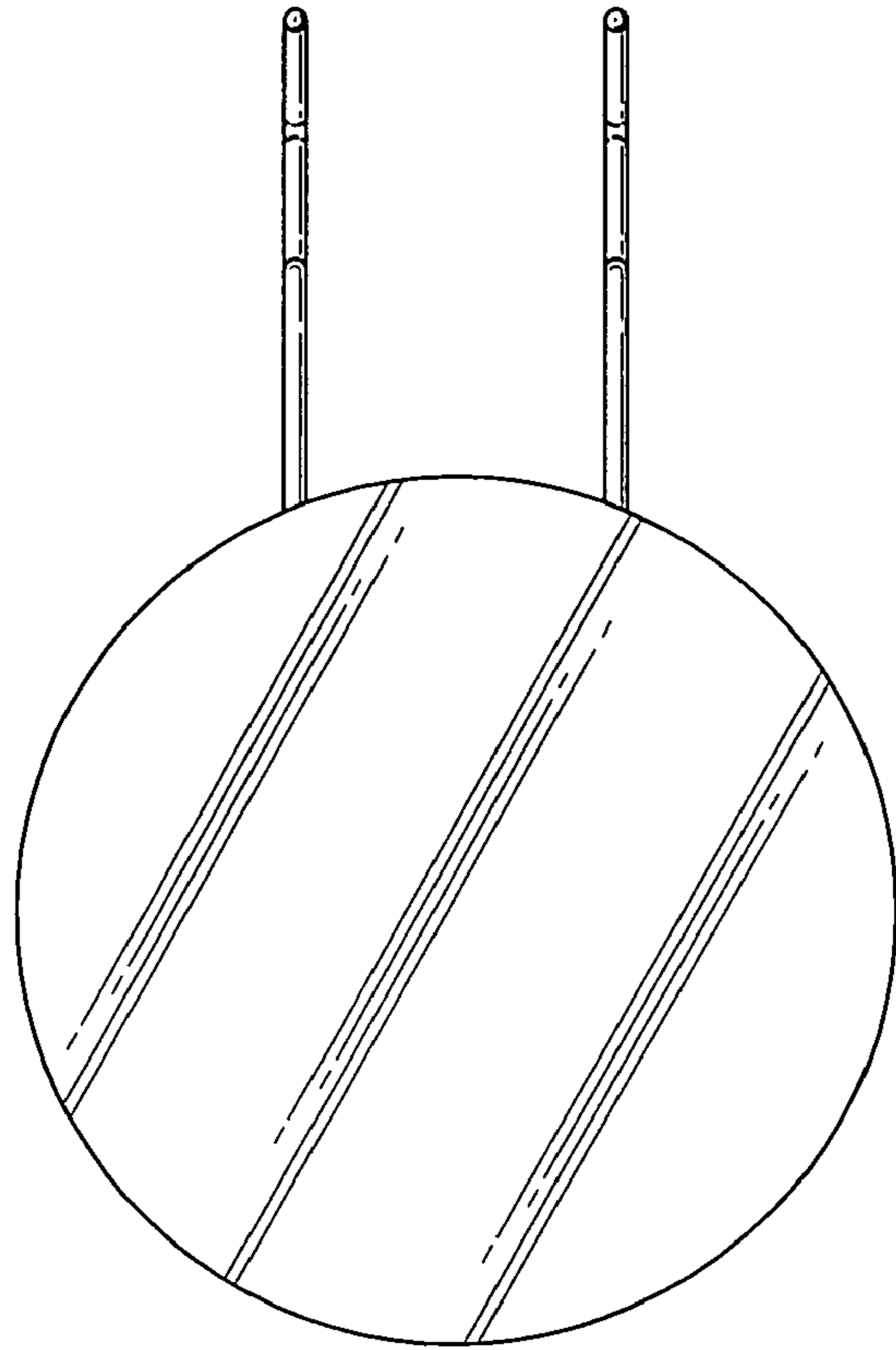

FIG. 3

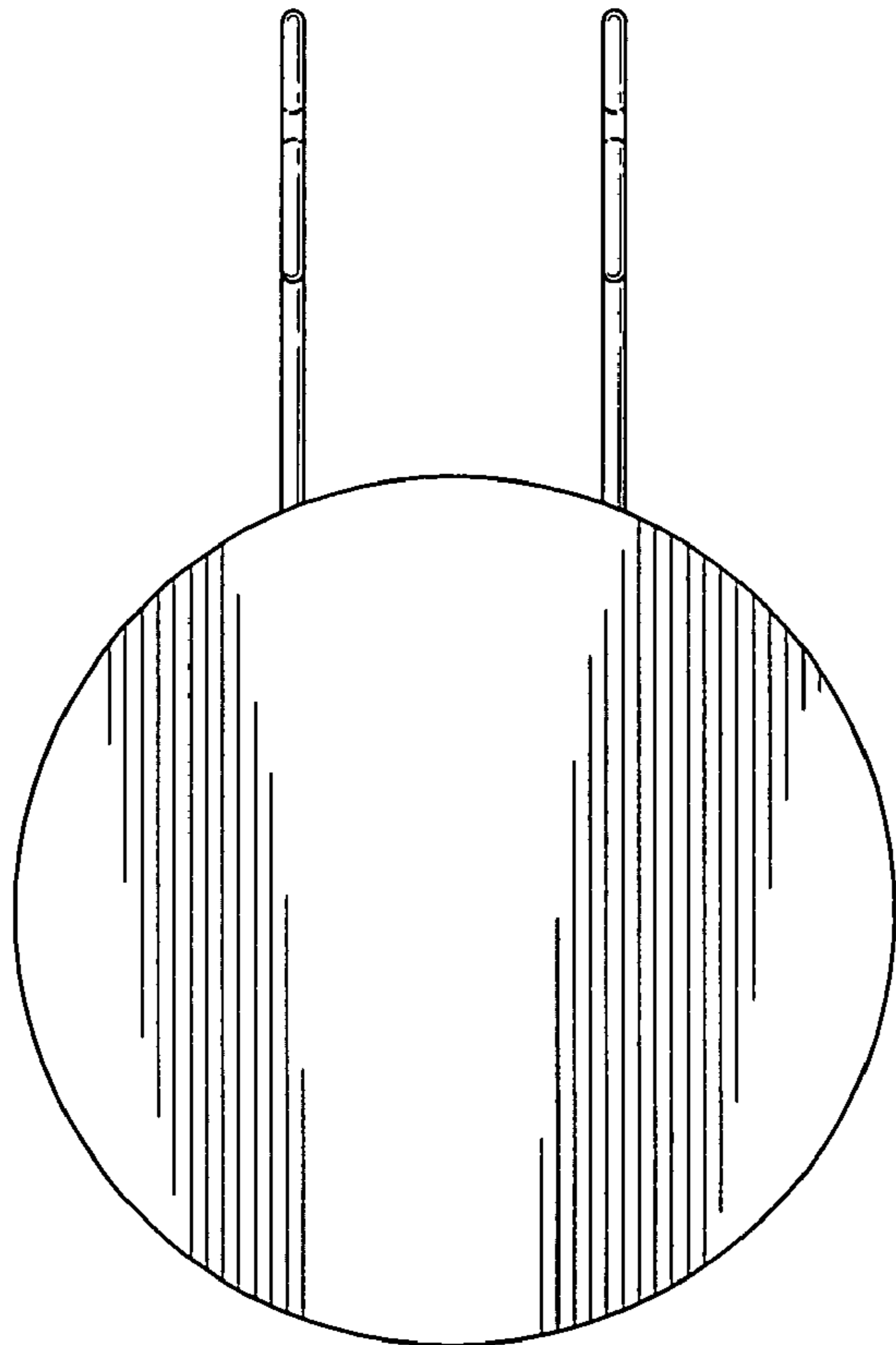

FIG. 4

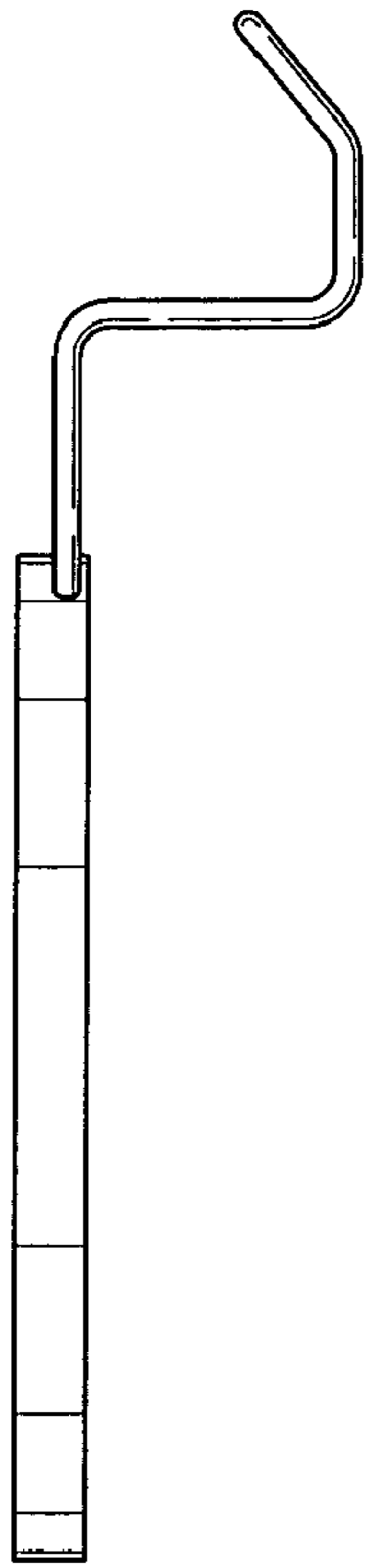

FIG. 5

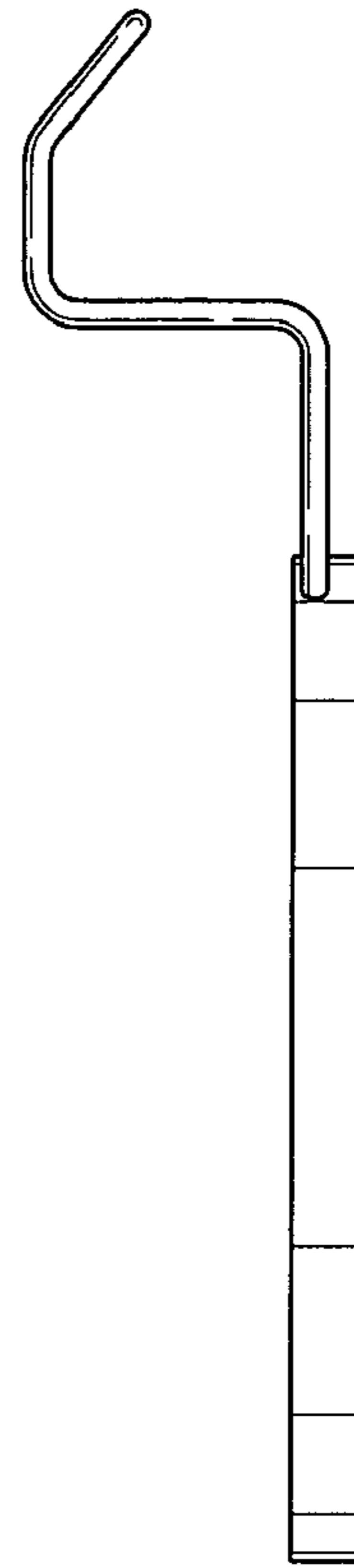

FIG. 6

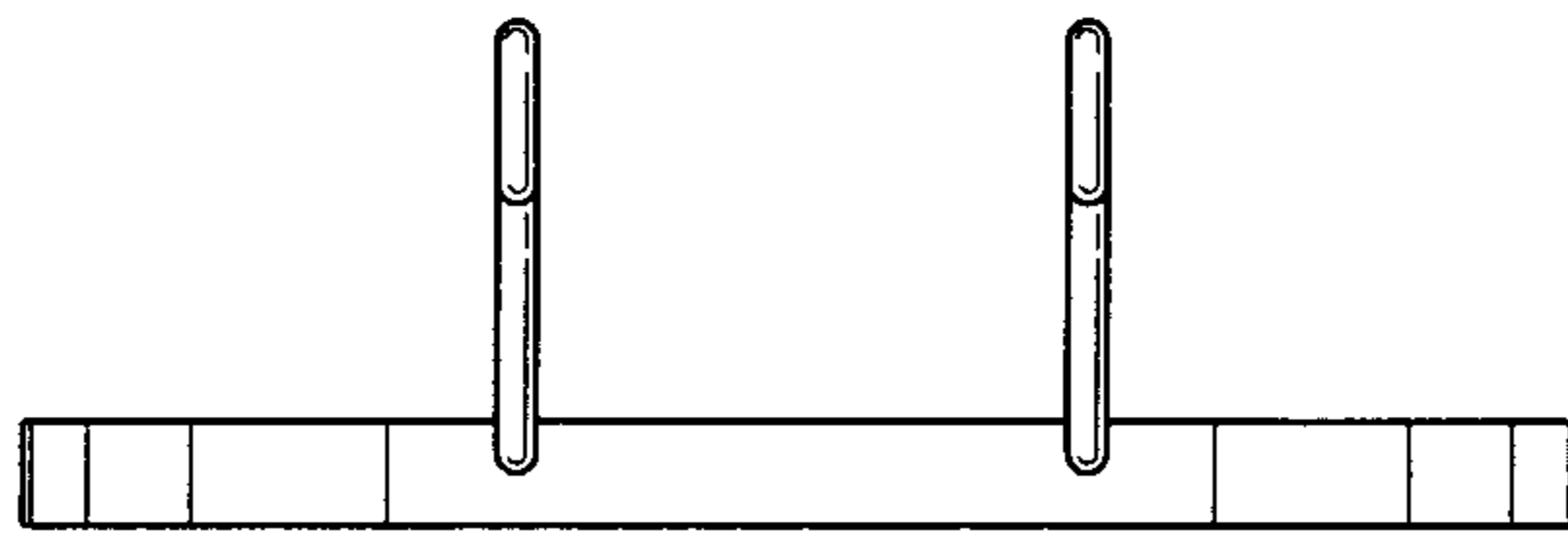

FIG. 7

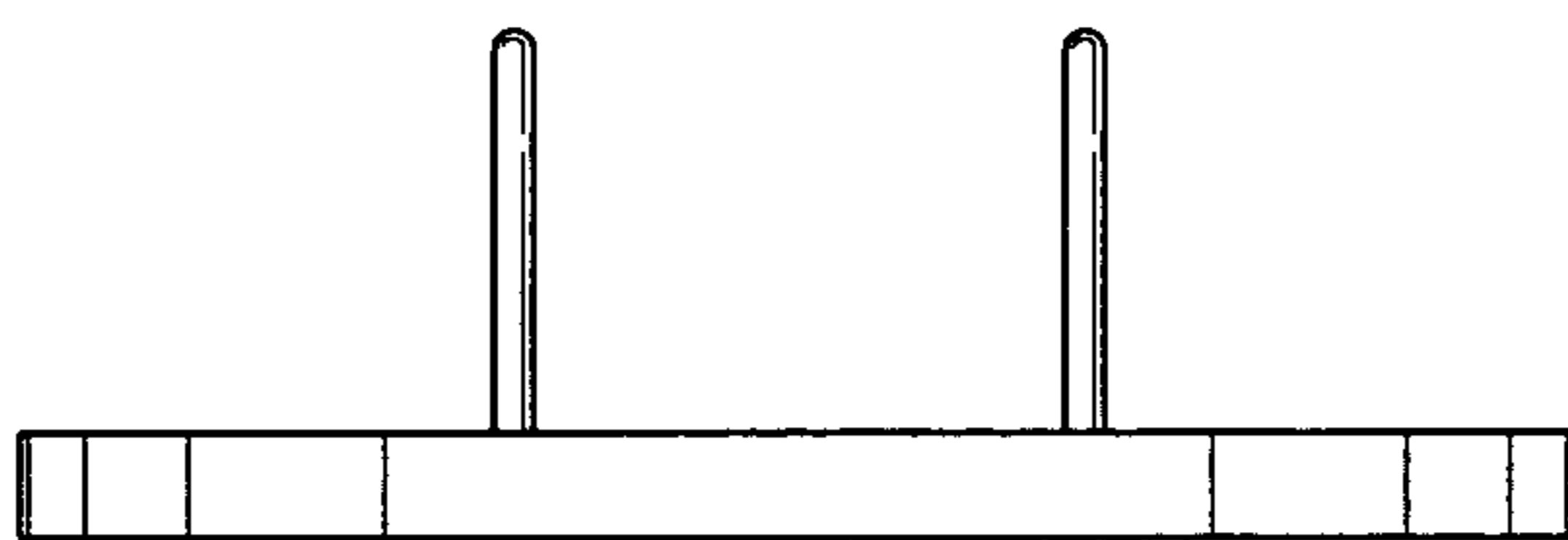

FIG. 8