



US00D592026S

(12) **United States Design Patent**
Okuda et al.

(10) **Patent No.:** **US D592,026 S**

(45) **Date of Patent:** **** May 12, 2009**

(54) **PORTABLE ELECTRIC GRINDER**

(75) Inventors: **Shinsuke Okuda**, Anjo (JP); **Tadashi Fukumoto**, Anjo (JP)

(73) Assignee: **Makita Corporation**, Anjo-Shi (JP)

(**) Term: **14 Years**

(21) Appl. No.: **29/323,491**

(22) Filed: **Aug. 26, 2008**

(30) **Foreign Application Priority Data**

Mar. 3, 2008 (JP) 2008-005037

(51) **LOC (9) Cl.** **08-01**

(52) **U.S. Cl.** **D8/62**

(58) **Field of Classification Search** D32/15,
D32/17, 19; D8/67, 62, 61; D4/102; 451/456,
451/451, 359, 358, 357, 356, 355, 354, 353,
451/351, 344; 310/50; 173/170

See application file for complete search history.

(56) **References Cited**

U.S. PATENT DOCUMENTS

D301,830 S *	6/1989	Ogawa et al.	D8/62
D328,841 S *	8/1992	Fushiya et al.	D8/62
D347,153 S	5/1994	Uneyama		
D351,772 S *	10/1994	Price	D8/62
D378,183 S *	2/1997	Dognini	D8/62
D394,594 S *	5/1998	Chung	D8/62
D402,870 S *	12/1998	Etter et al.	D8/62
D408,244 S *	4/1999	Price	D8/62
D423,898 S *	5/2000	Kelley	D8/64

D437,199 S *	2/2001	Robson	D8/62
D438,077 S *	2/2001	Schmid	D8/61
D453,098 S *	1/2002	Pretzell	D8/62
D468,179 S *	1/2003	Hayakawa et al.	D8/62
D479,452 S *	9/2003	Cho	D8/62
D479,969 S *	9/2003	Robson et al.	D8/62
D491,033 S *	6/2004	Bian	D8/62
D500,945 S *	1/2005	Wright	D8/62
D528,389 S *	9/2006	Wu	D8/62
D528,887 S *	9/2006	Wright	D8/62
D531,868 S *	11/2006	Zurwelle	D8/62
D544,326 S *	6/2007	Sterpka et al.	D8/62

* cited by examiner

Primary Examiner—Cathron C Brooks

Assistant Examiner—Austin Murphy

(74) *Attorney, Agent, or Firm*—Oloff & Berridge, PLC

(57) **CLAIM**

The ornamental design for a portable electric grinder, as shown and described.

DESCRIPTION

FIG. 1 is a perspective view of top, front and left side of a portable electric grinder showing our new design;

FIG. 2 is a front view thereof;

FIG. 3 is a rear view thereof;

FIG. 4 is a top plan view thereof;

FIG. 5 is a bottom view thereof;

FIG. 6 is a right side view thereof; and,

FIG. 7 is a left side view thereof.

1 Claim, 6 Drawing Sheets

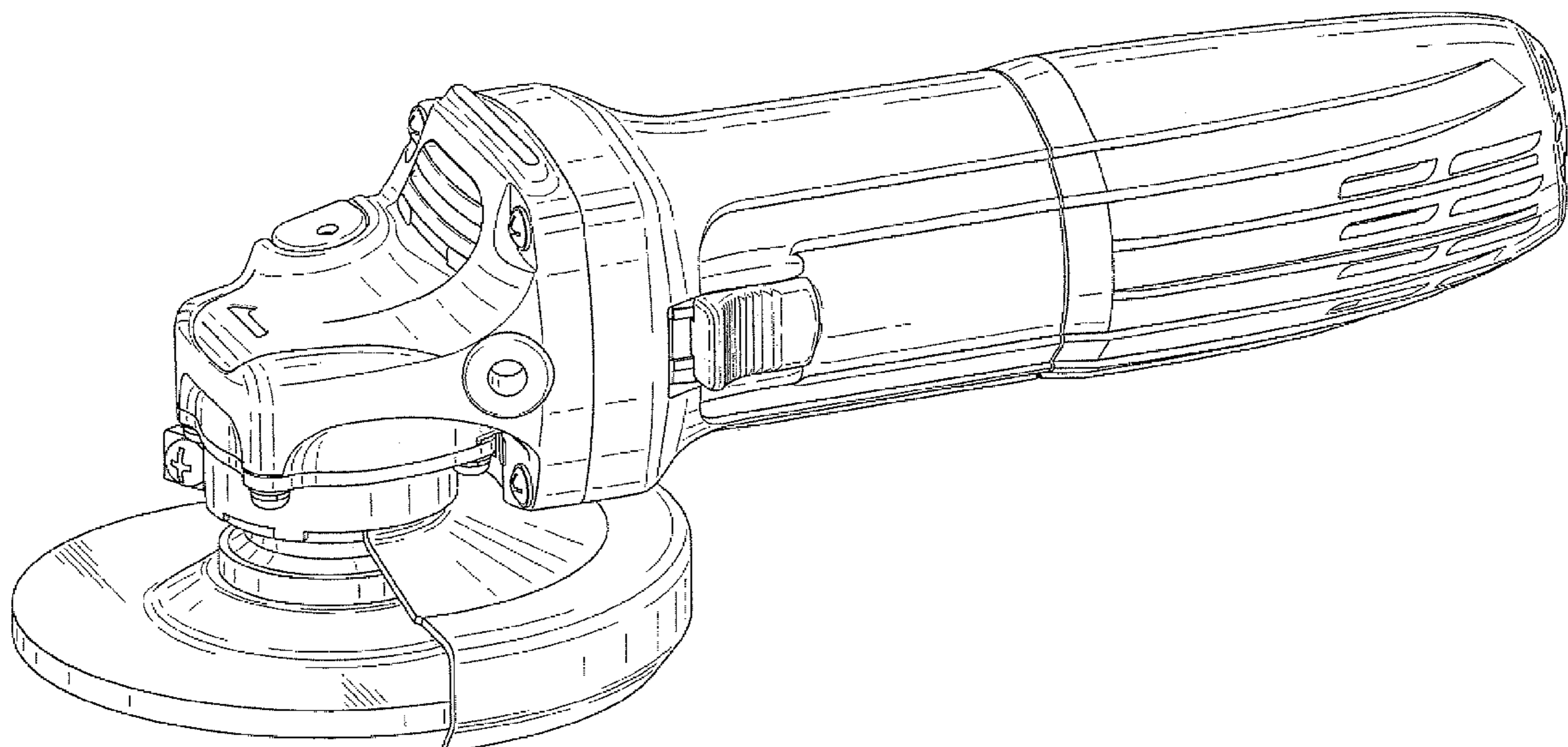

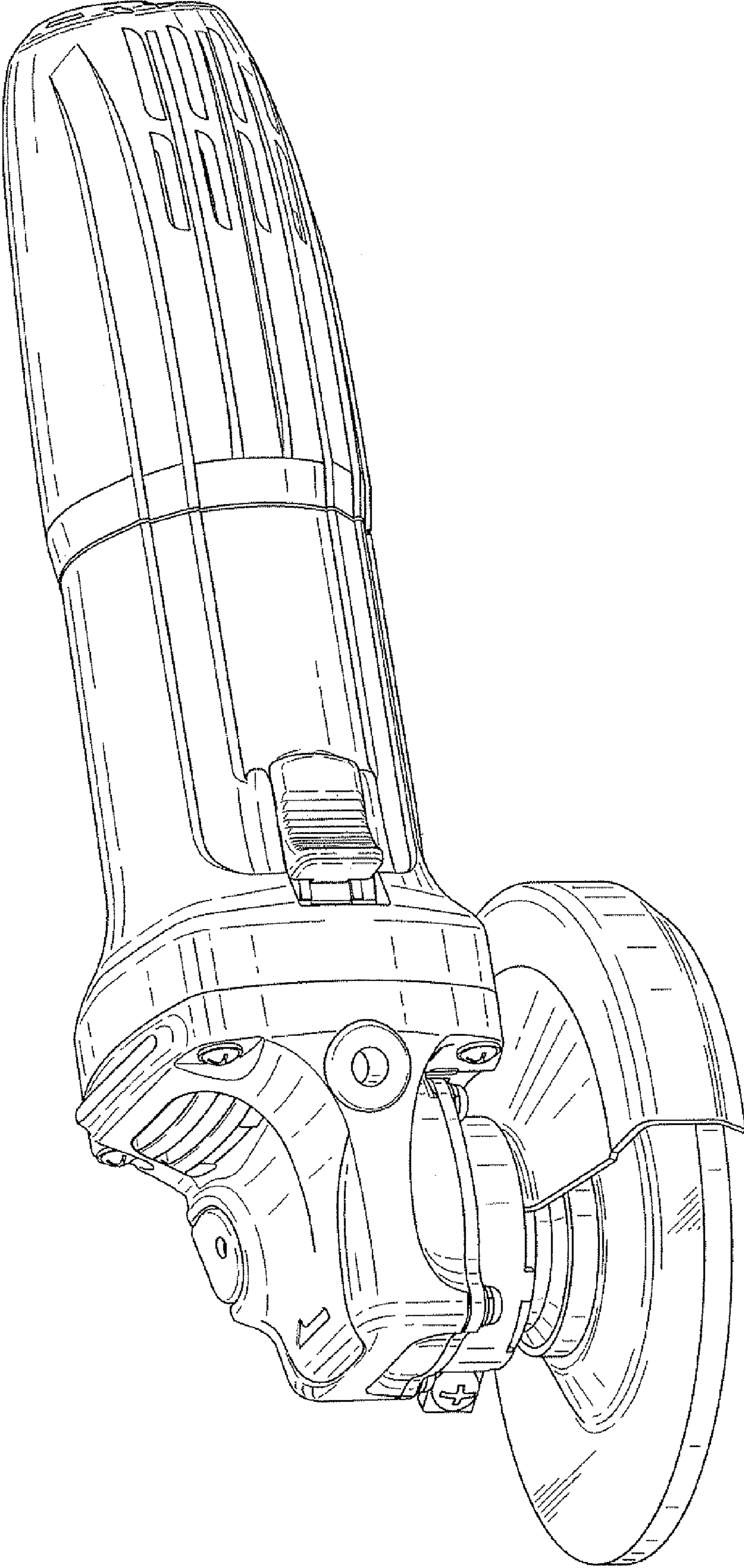

FIG. 1

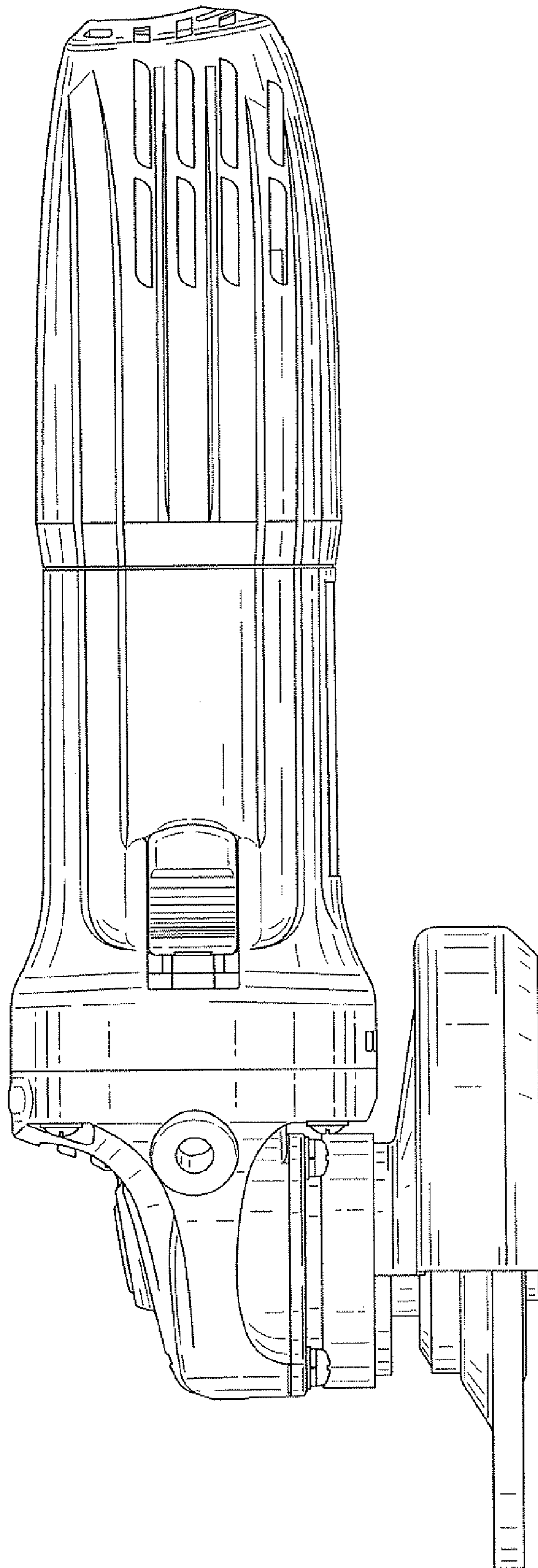

FIG. 2

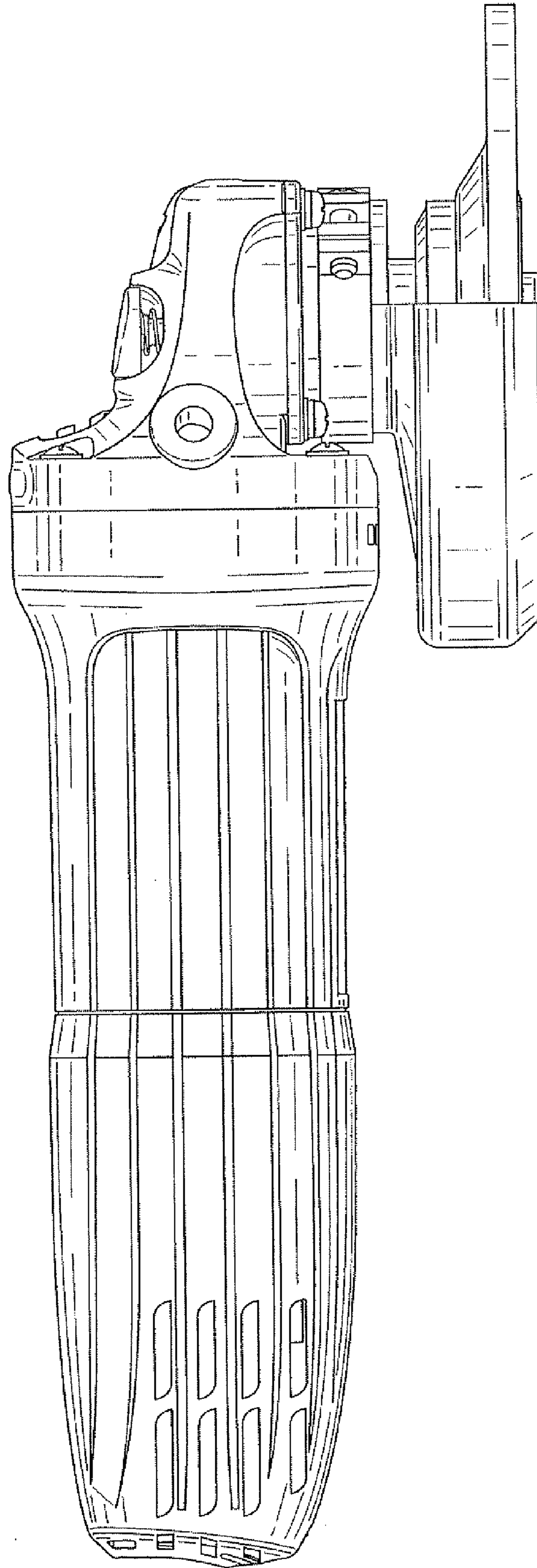

FIG. 3

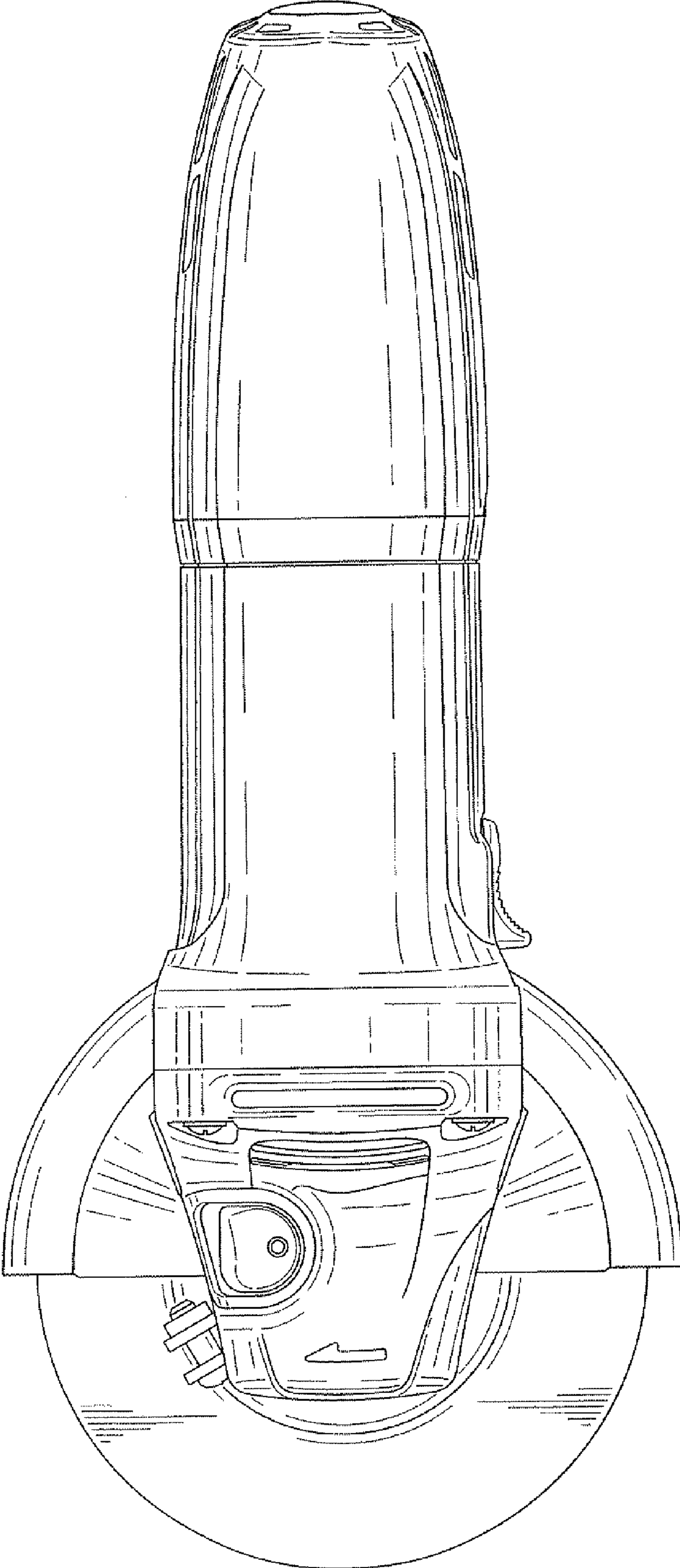

FIG. 4

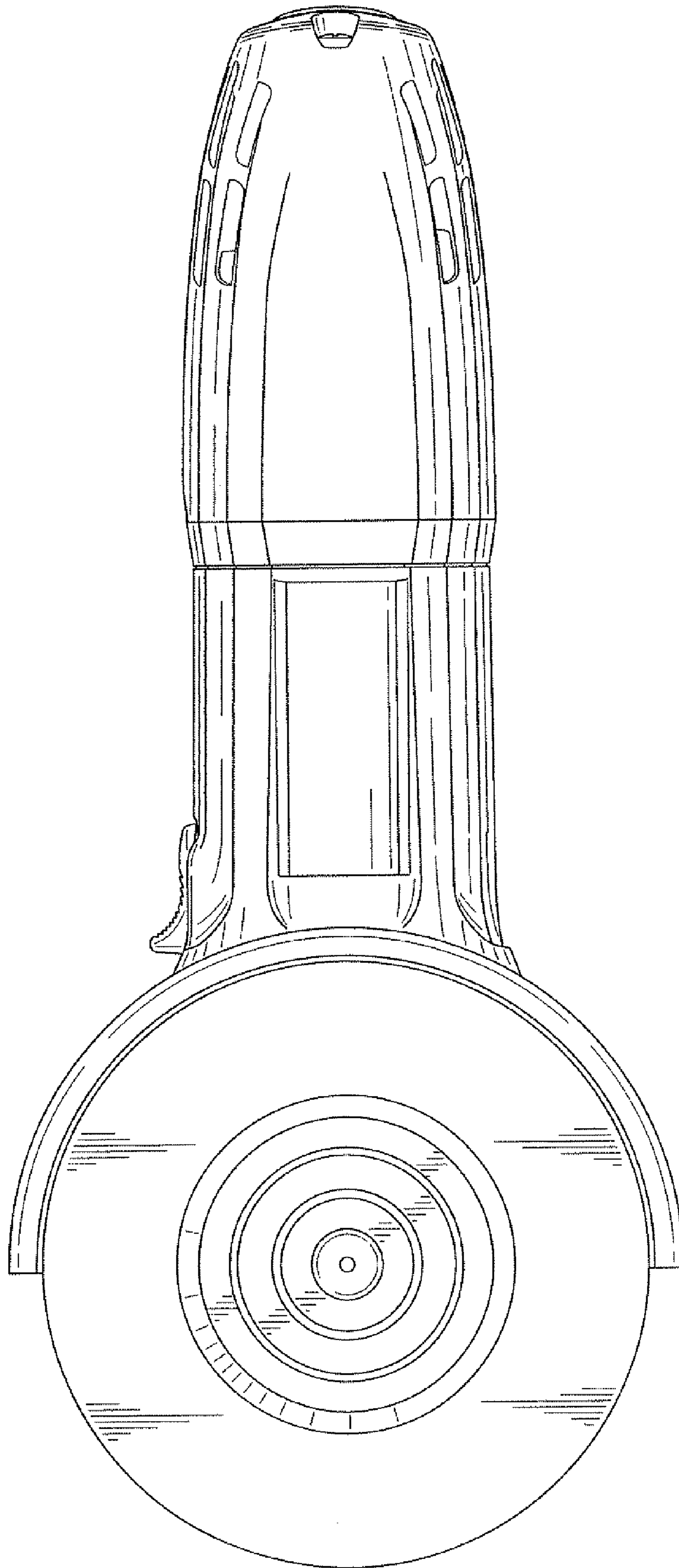

FIG. 5

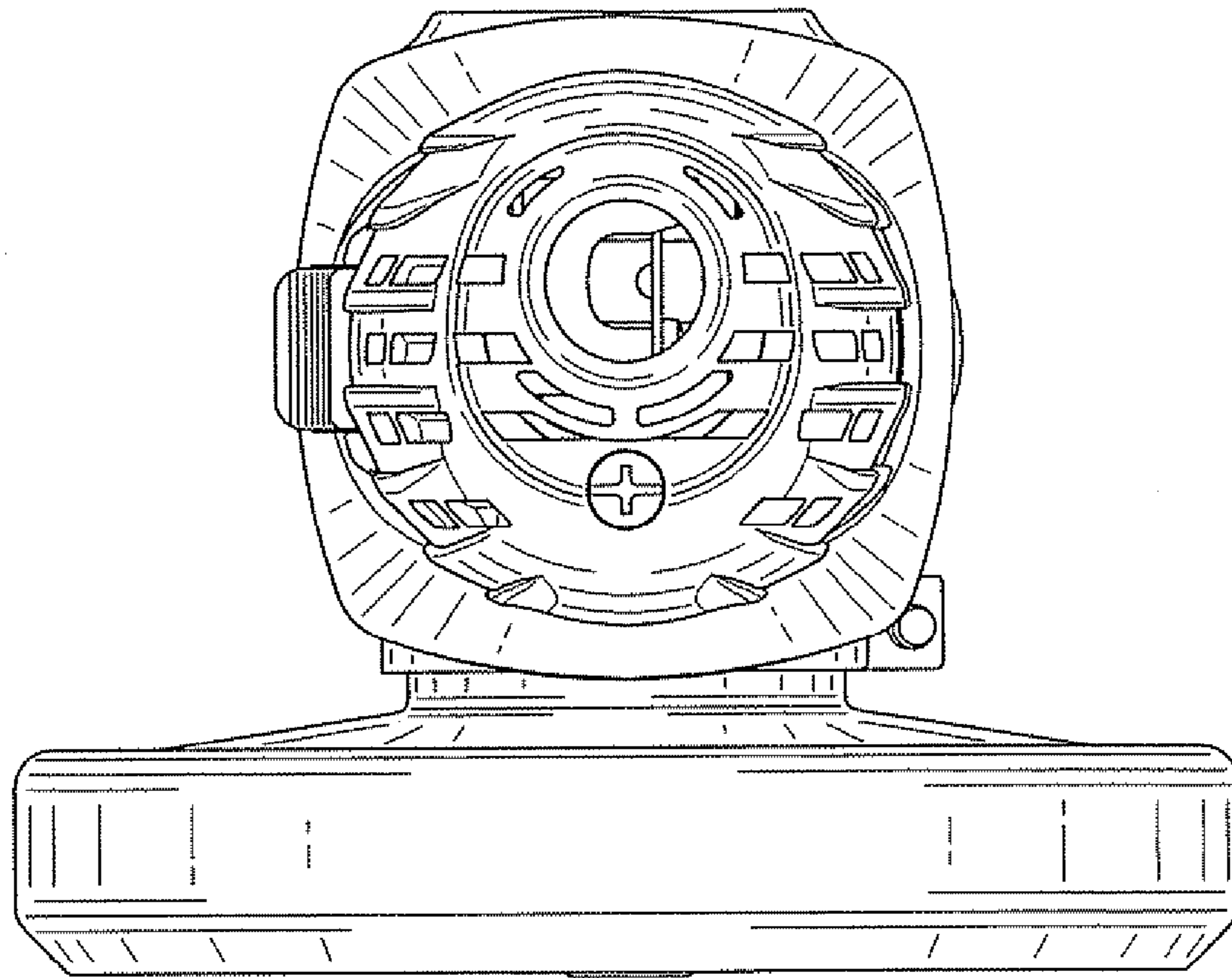

FIG. 6

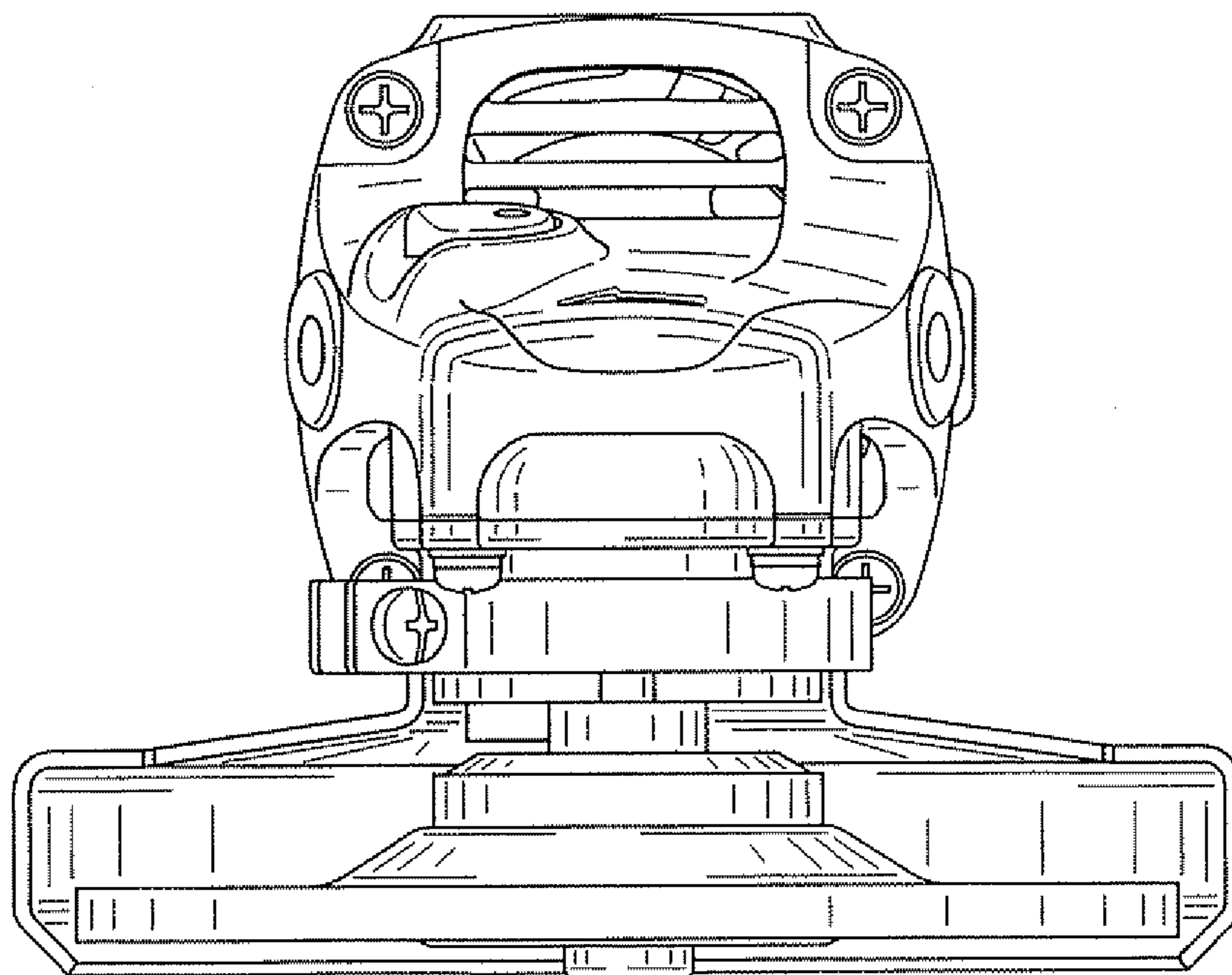

FIG. 7