



US00D591067S

(12) **United States Design Patent**
Suge et al.

(10) **Patent No.:** **US D591,067 S**
(45) **Date of Patent:** **** Apr. 28, 2009**

(54) **AIRCRAFT SEAT**

(75) Inventors: **Yasutaka Suge**, Tokyo (JP); **Yuichi Akutsu**, Tokyo (JP); **Manabu Matsumoto**, Tokyo (JP)

(73) Assignee: **Japn Airlines International Co., Ltd.**, Tokyo (JP)

(**) Term: **14 Years**

(21) Appl. No.: **29/287,255**

(22) Filed: **Jul. 16, 2007**

(30) **Foreign Application Priority Data**

Jan. 16, 2007 (JP) D2007-000636

(51) **LOC (9) Cl.** **06-01**

(52) **U.S. Cl.** **D6/356; D6/360; D6/381; D12/345**

(58) **Field of Classification Search** D12/317-319, D12/345, 400; D6/334-335, 356, 360-361, D6/367, 381, 500; 244/117 R, 118.5, 118.6, 244/112 R; 105/345; 114/363, 194
See application file for complete search history.

(56) **References Cited**

U.S. PATENT DOCUMENTS

D166,938 S * 6/1952 Weltz D6/356
D411,922 S * 7/1999 Granados D6/356

D488,629 S * 4/2004 Giasson D6/356
D521,281 S * 5/2006 Luebke D6/500
D535,123 S * 1/2007 Garcia D6/492
D565,855 S * 4/2008 Takahashi et al. D6/367
D572,950 S * 7/2008 Aoki et al. D6/501

* cited by examiner

Primary Examiner—Charles A Rademaker

Assistant Examiner—Dana L Sipos

(74) *Attorney, Agent, or Firm*—Rader, Fishman & Grauer, PLLC

(57) **CLAIM**

The ornamental design for an aircraft seat, as shown and described.

DESCRIPTION

FIG. 1 is a front elevational view of an aircraft seat showing our new design;

FIG. 2 is a rear elevational view thereof;

FIG. 3 is a left elevational view thereof;

FIG. 4 is a right side elevational view thereof;

FIG. 5 is a top plan view thereof;

FIG. 6 is a bottom plan view thereof; and,

FIG. 7 is a front right perspective view thereof.

The portions indicated in broken lines are for illustrative purposes only and form no part of the claimed design.

1 Claim, 7 Drawing Sheets

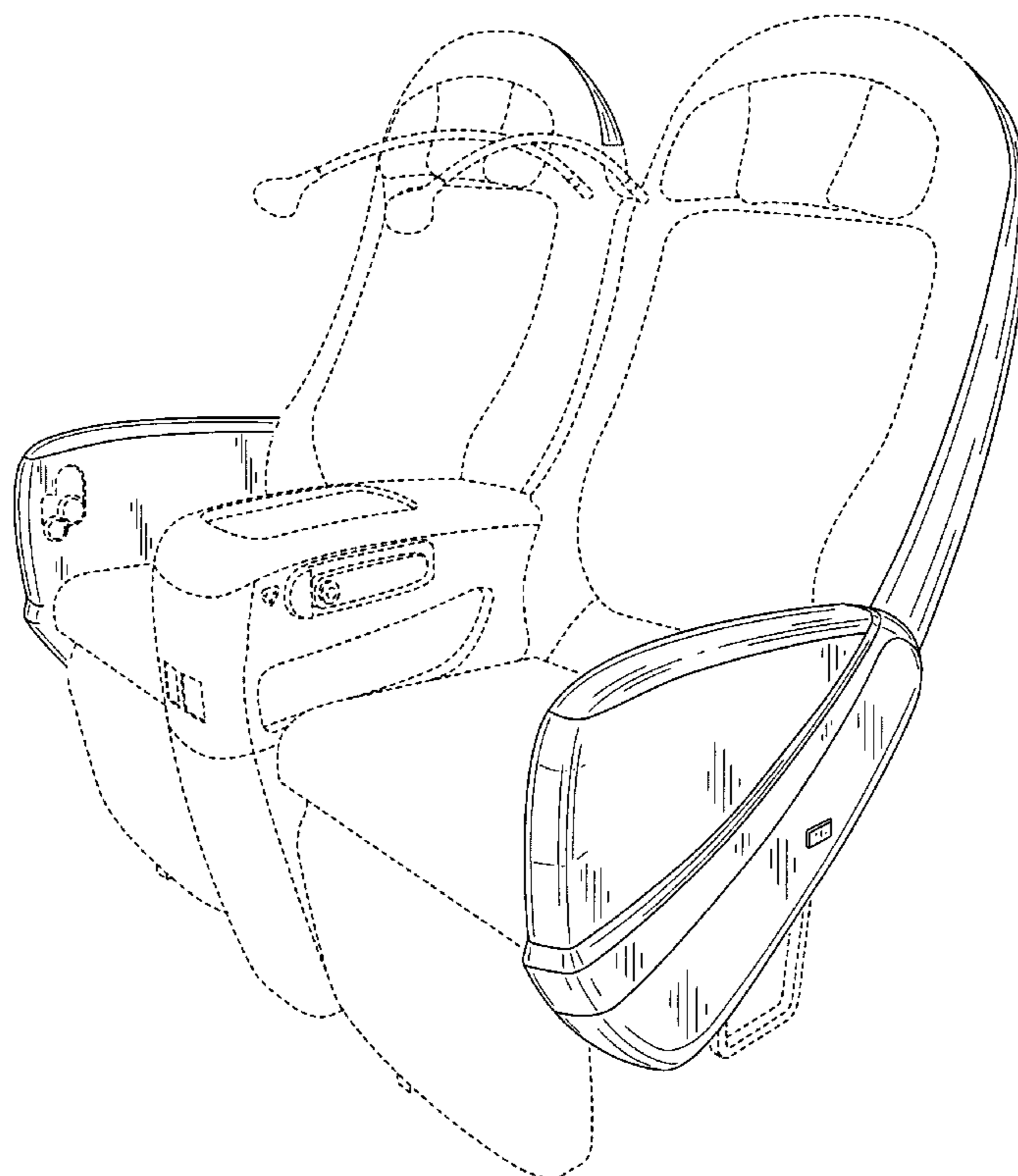

Fig.1

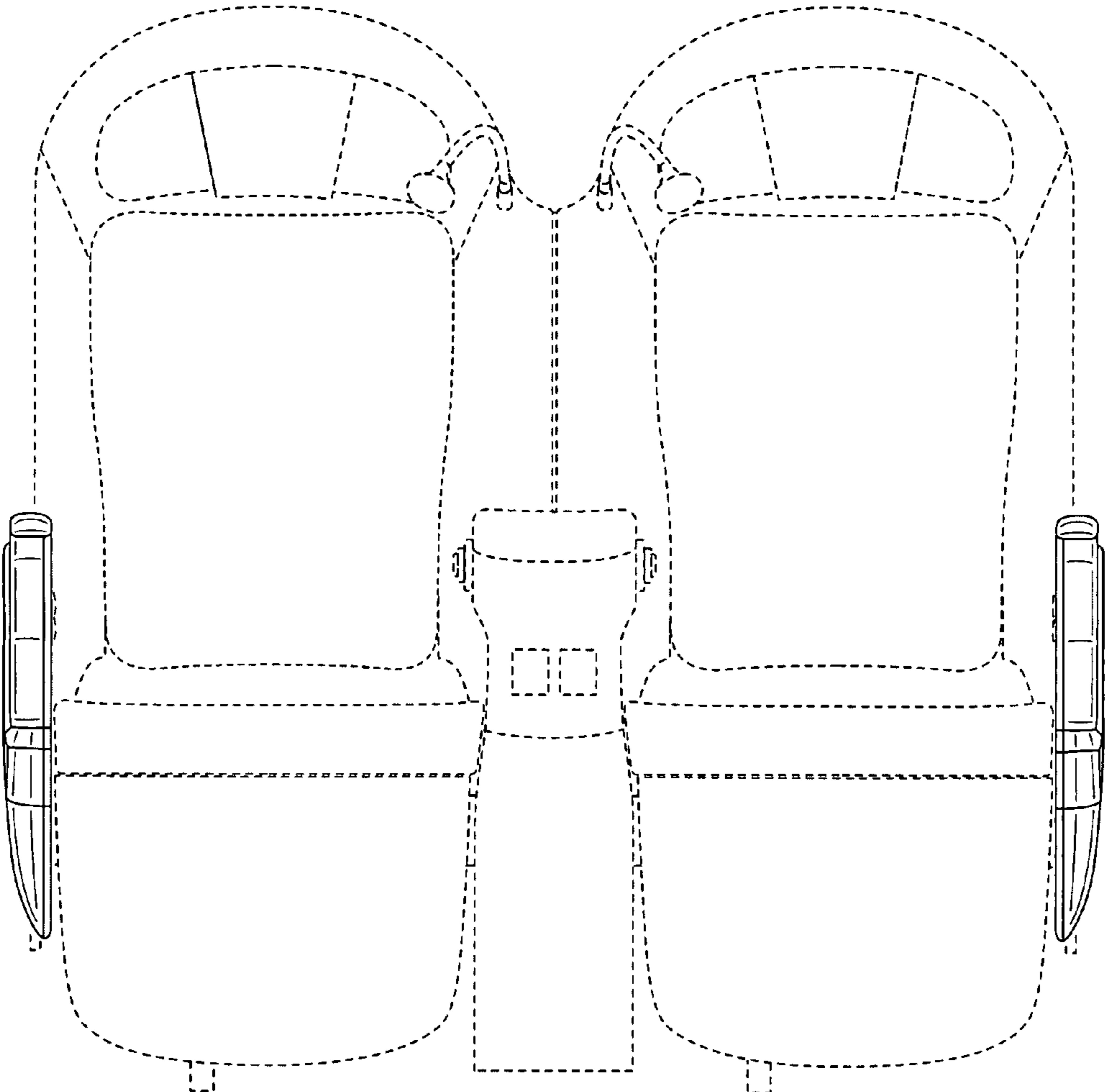

Fig.2

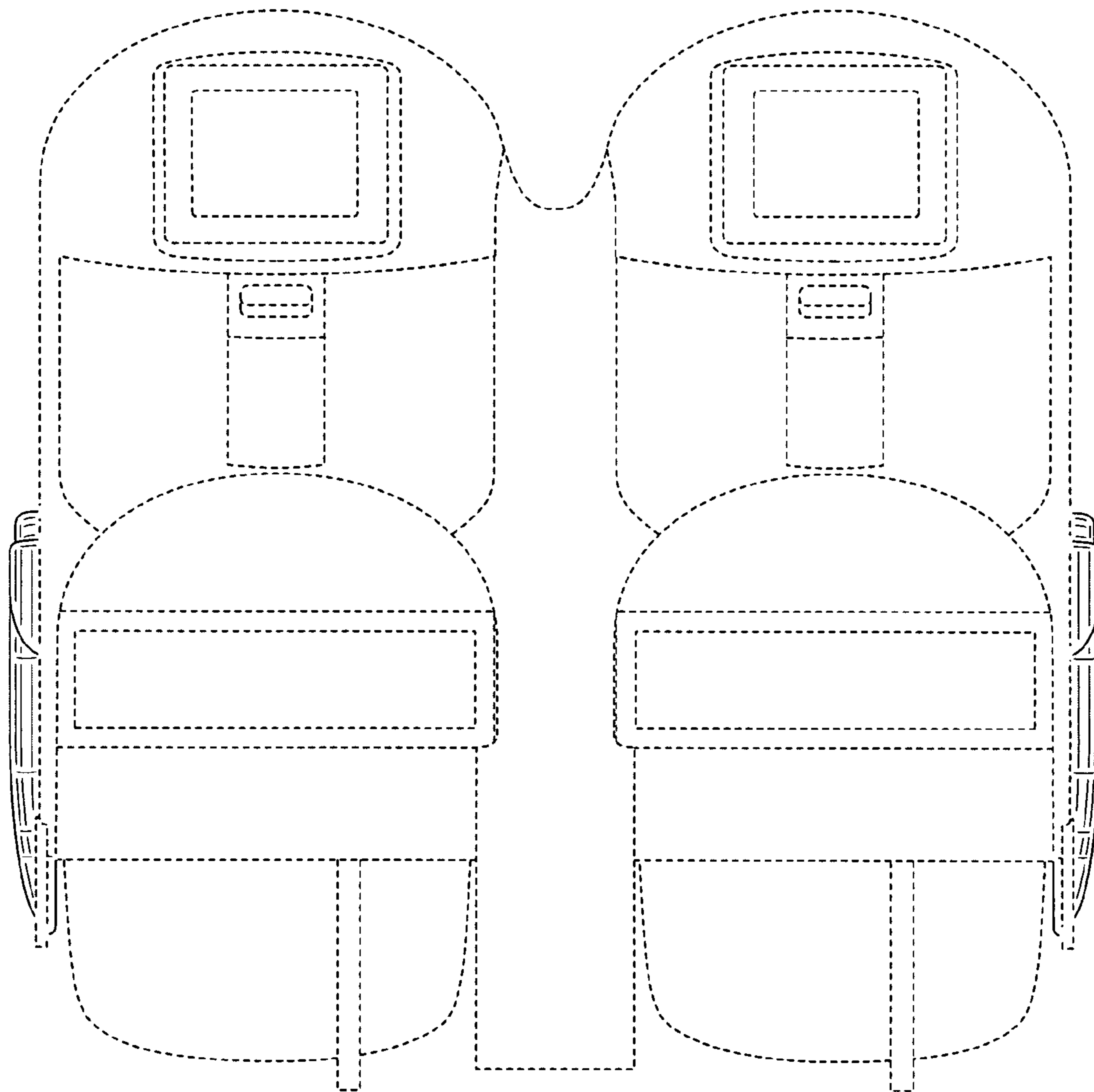

Fig.3

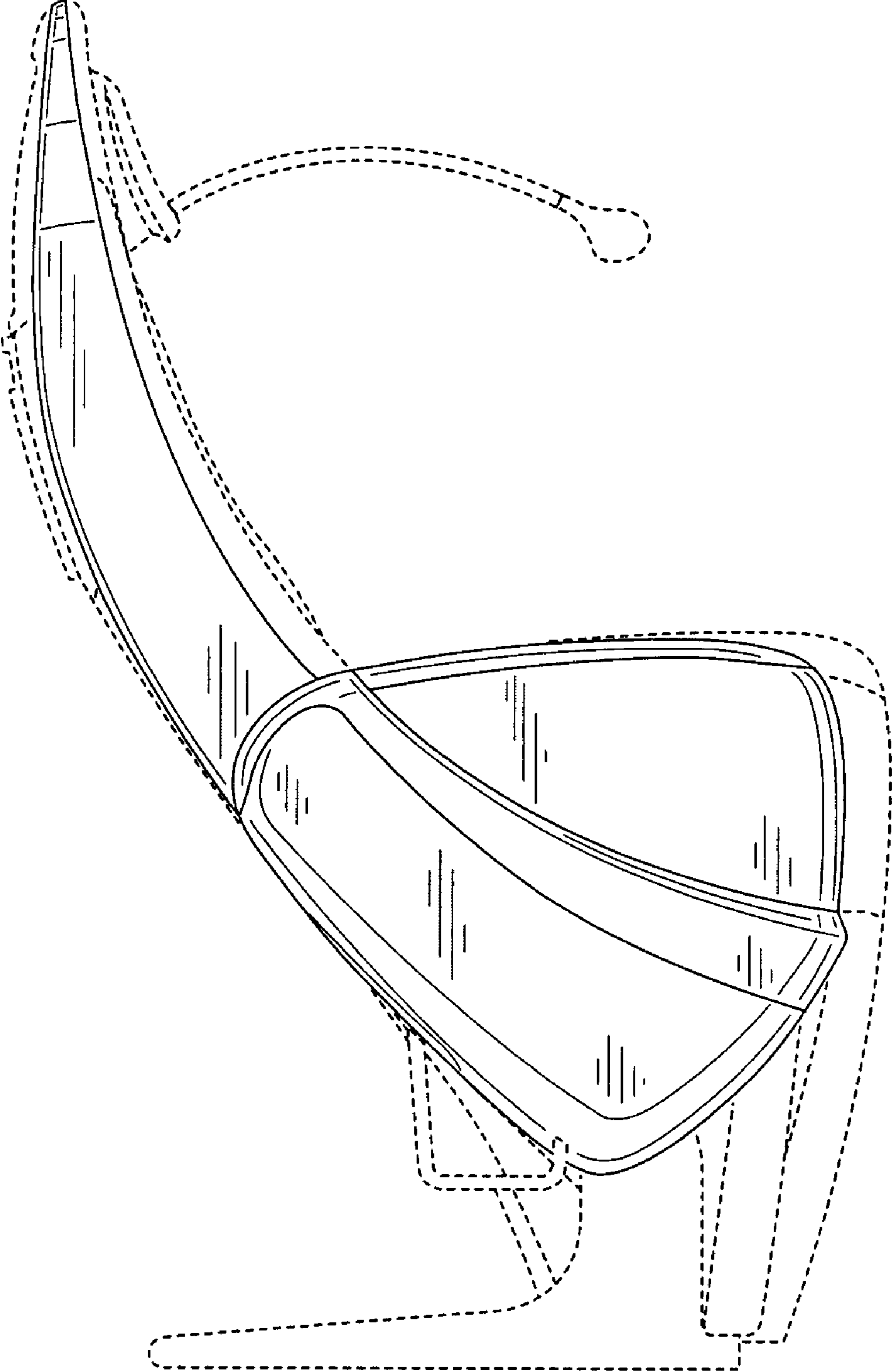

Fig.4

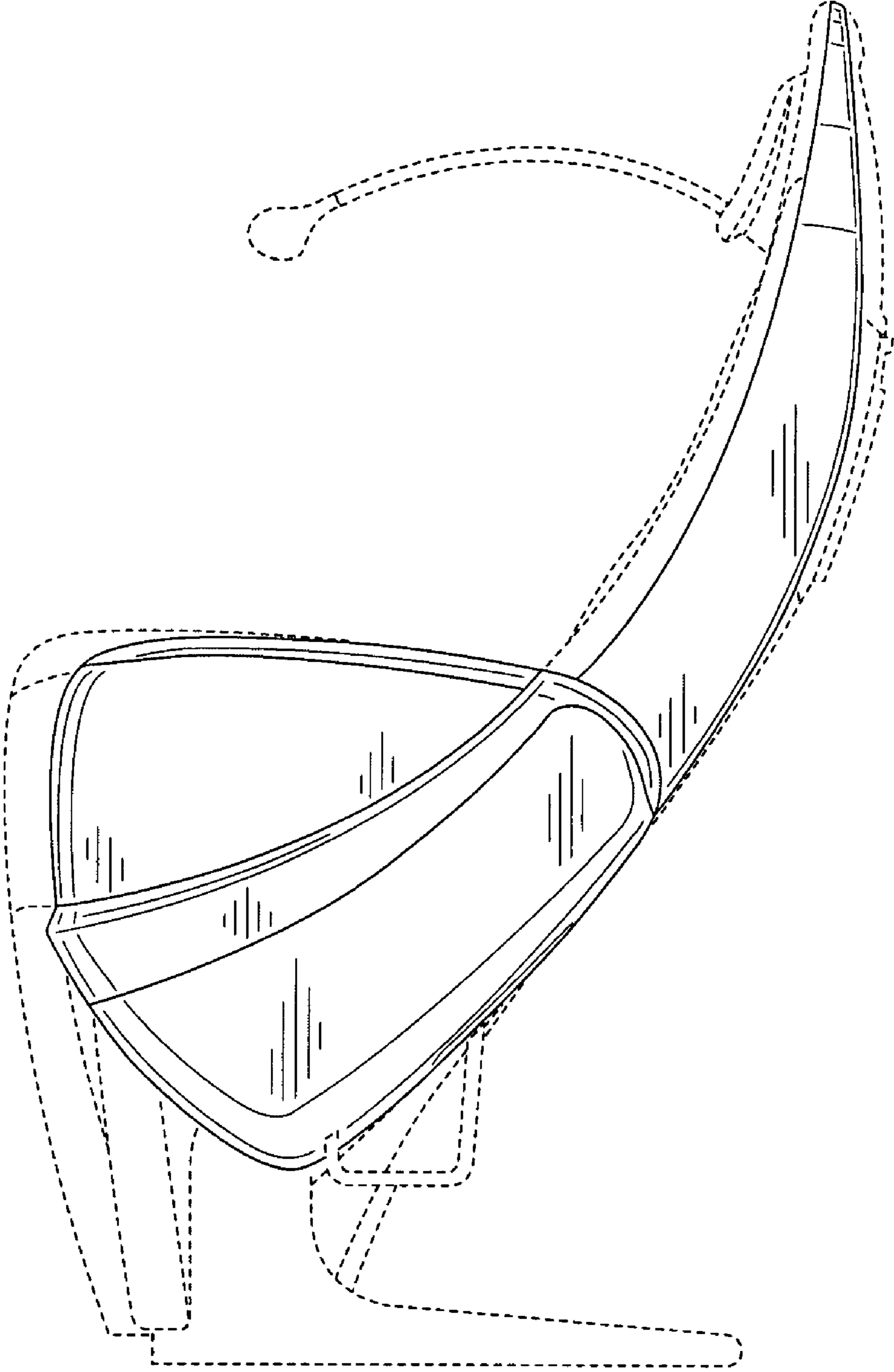

Fig.5

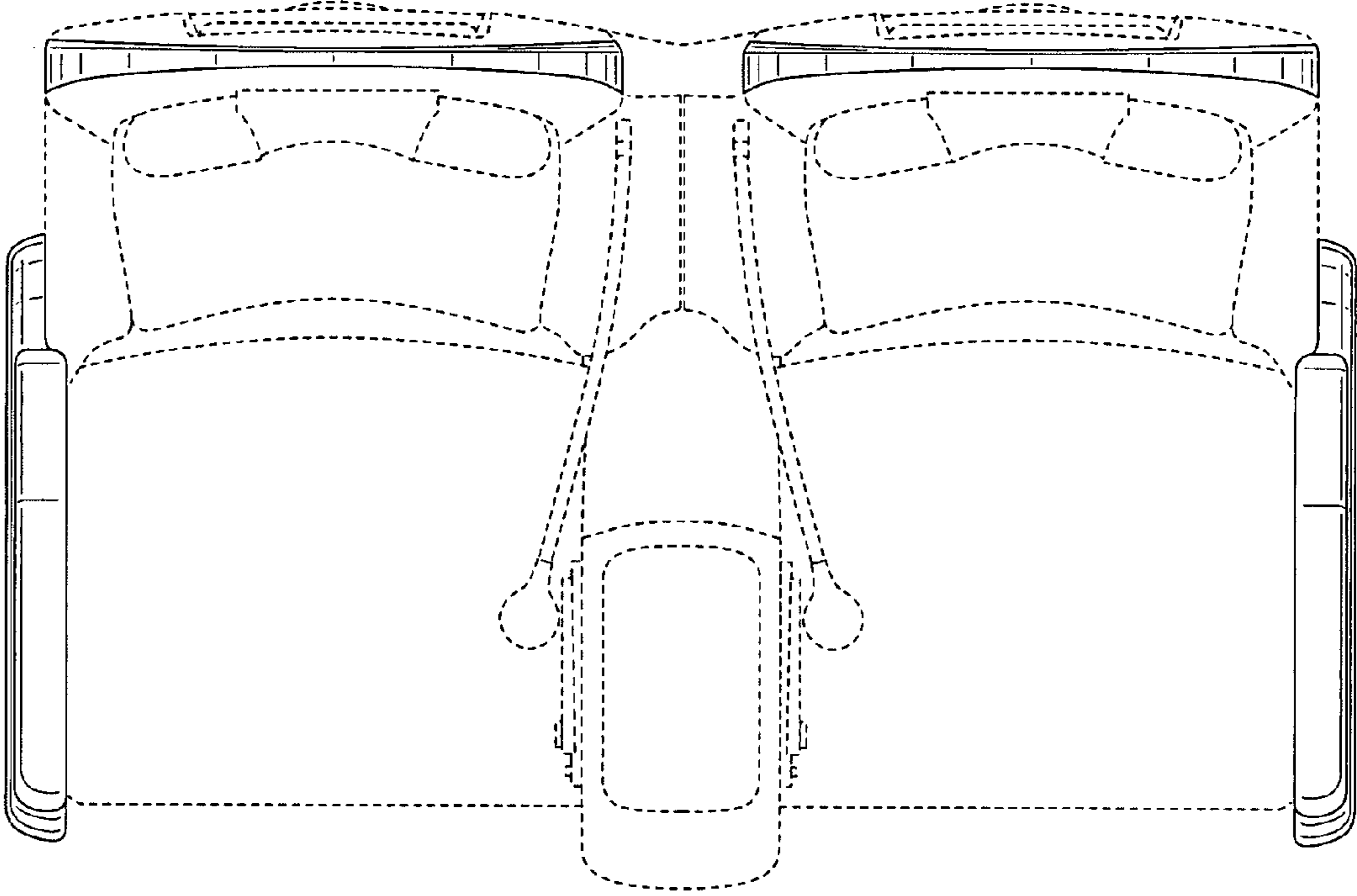

Fig.6

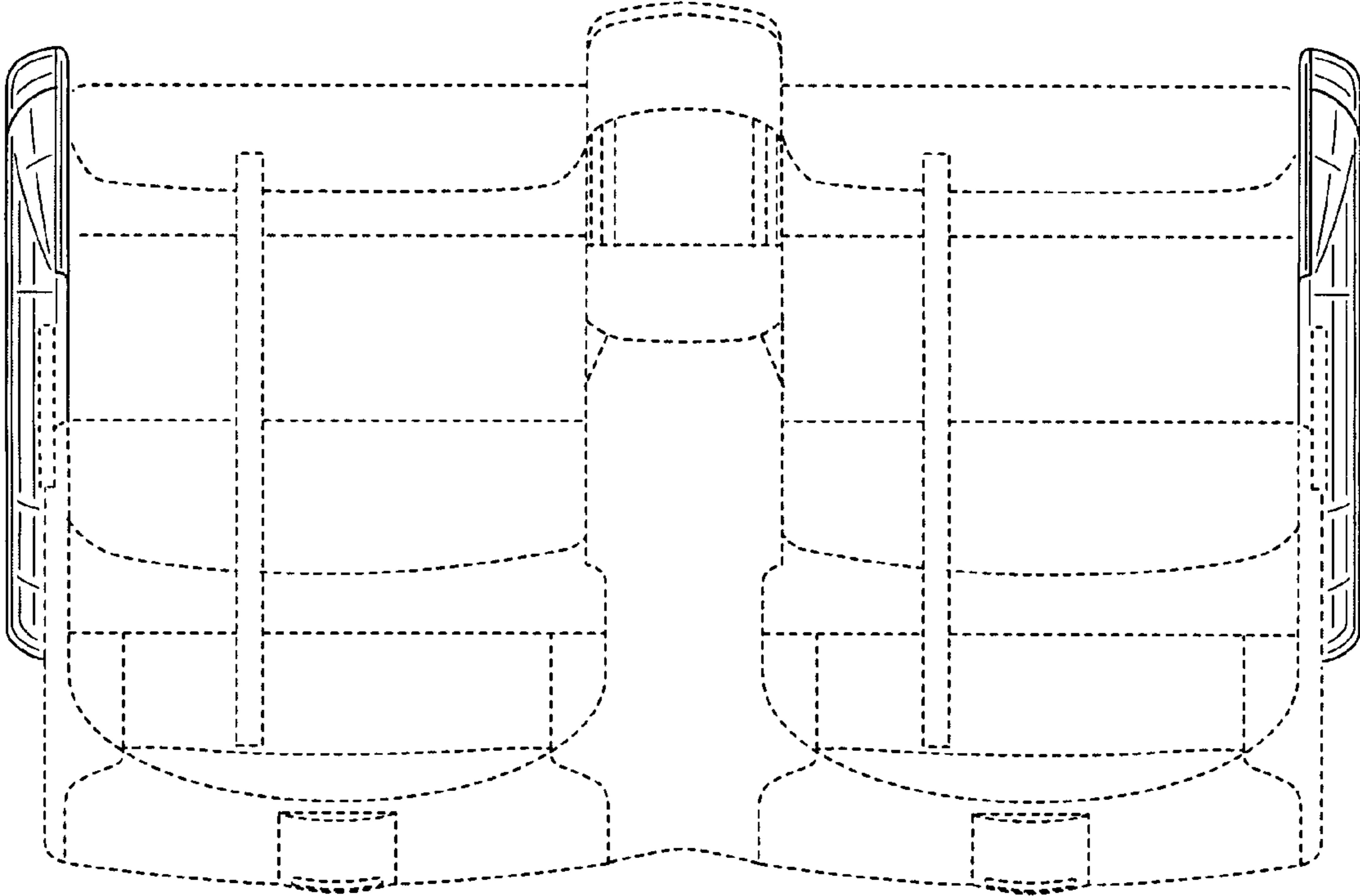

Fig.7

